

Tips for Avoiding Crane Runway Problems

DAVID T. RICKER

Mill and heavy industrial type buildings are usually designed with two main functions in mind: to provide a sheltered work area and to support lifting devices which serve to move loads from one location to another. Providing shelter involves fairly routine design procedures, utilizing well-known and tested guidelines. But supporting the transporting device, or crane system, is a more complicated and intricate task and efforts in this regard have not always been successful. In fact, many otherwise sound heavy industrial structures are plagued with problems which stem from the method of supporting the crane system.

There are several different types of cranes: overhead traveling, underslung, jib, gantry, and monorail are among the most common. A building may contain one or several of the above, either singly or in various combinations.

Although all of these cranes have their own special problems, this paper is concerned with the one which generally has the potential to deal the most punishment to its supporting system—the overhead traveling crane. This type of crane is available in a vast range of capacities from 1 ton to well over 300 tons.

An overhead traveling crane runway system consists of the following components:

1. The crane, comprising the bridge girder, end trucks, trolley, hoist, power transmitting devices, and usually a cab which houses the controls and operator. (See Fig. 1.)
2. The crane rails and their attachments.
3. The crane beams, girders, or trusses.
4. The crane columns, or bents.
5. The crane column bracing.
6. The crane column foundations.
7. The crane stops.
8. The conductor rail supports.

David T. Ricker is Chief Engineer, The Berlin Steel Construction Co., Inc., Berlin, Connecticut.

The crane (or cranes) directly affects the other components of the structure. When the owner selects the crane, he must consider load capacity, space limitations, and the class of service which he requires. When designing the crane runway, the engineer takes into account these requirements plus other factors such as potential future changes in load capacity, the addition of other cranes, various load combinations, and the possible extension of the runway. Few other structures suffer such an extreme range of stresses and as high an incidence of maximum loadings and fatigue as crane runways, and this must also be considered by the engineer. In addition he must be aware of the infinite variety of abuses inflicted on crane systems, such as hoisting loads which exceed the crane capacity, swinging loads pendulum fashion, dragging loads longitudinally along the crane runway, dragging loads laterally from one crane aisle to another, dropping loads pile driver fashion (as when freeing heavy castings from their molds), and ramming the crane against the crane stops at excessive speed to realign the bridge (make it perpendicular to the rails). Murphy's Law is liberally applied in most plants with unbelievable ingenuity—if something *can* happen it *will* happen, sooner or later. The runway had best be able to handle it. An unsuspecting engineer, guided mainly by economics, may be lulled into designing a runway component as he would any other member in the structure; he is then often appalled by the rapid and violent deterioration of his handywork. The crane runway is often one of the most important parts of an industrial operation; significant "down time" required for repairs and maintenance can be disastrous to the owner.

AISC has established reduced allowable stresses for fatigue loadings (AISC Manual,¹ 8th Edition, Appendix B) and guidelines for impact and horizontal loads for crane runways (AISC Specification Sects. 1.3.3 and 1.3.4). References 2 and 3 (both available from AISC) contain much worthwhile information regarding crane runway design and performance and must be considered among the definitive references on the subject today.

This paper is intended to expose and discuss some of the problems associated with crane runways. It will examine each of the eight components of the crane runway, pointing

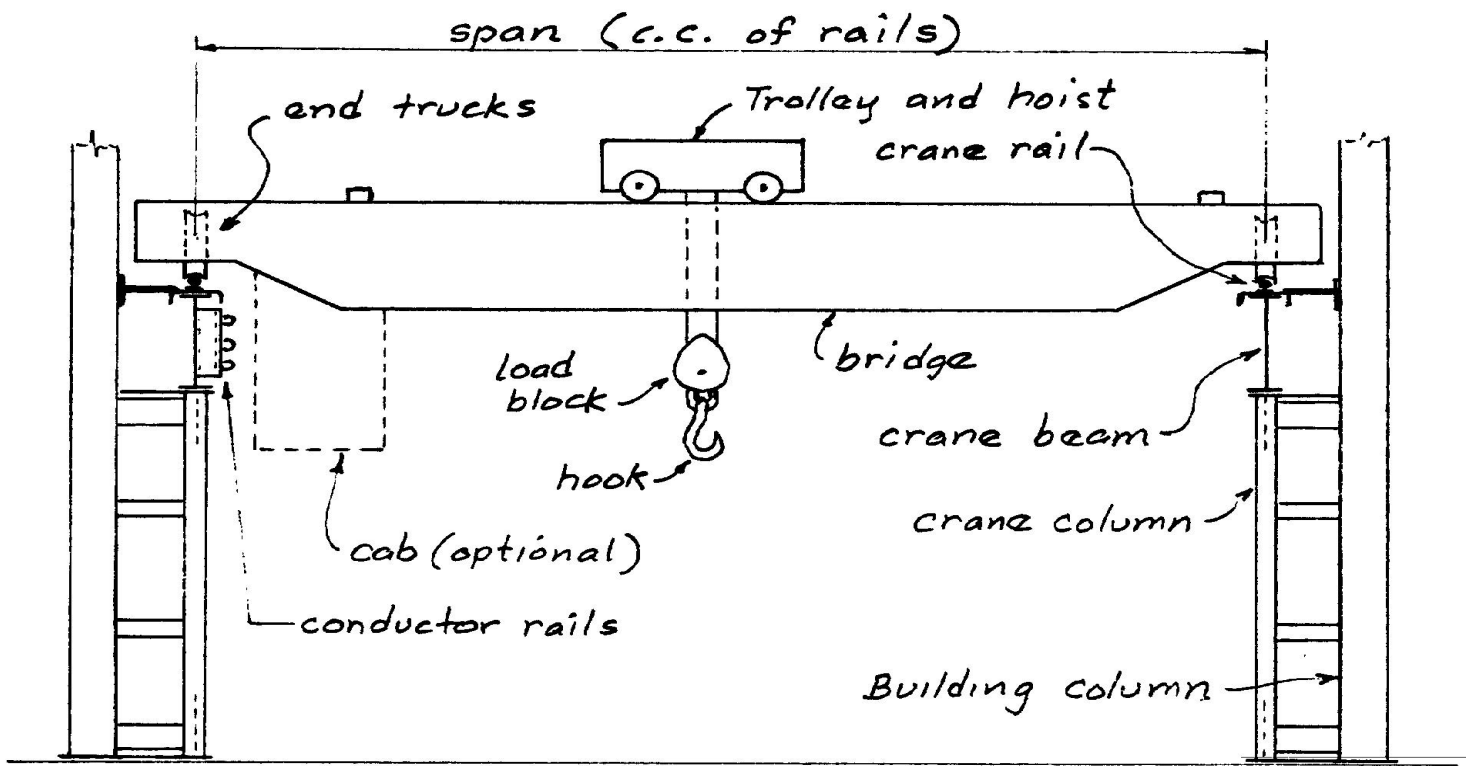

Figure 1

out pitfalls, dos-and-don'ts, suggested details and safeguards, and certain aspects which are considered good practice today. It is *not* the intent herein to instruct engineers in how to design a crane runway; this subject is amply covered in many texts, including the aforementioned references.

CRANE SERVICE CLASSIFICATIONS

The Crane Manufacturers Association of America (CMAA) has established service classifications⁴ to aid a purchaser in selecting the most economical crane to satisfy his particular requirements. These classifications are as follows:

Class A1 (Standby Service) —This service class covers cranes used in installations such as power houses, public utilities, turbine rooms, nuclear reactor buildings, motor rooms, nuclear fuel handling and transformer stations, where precise handling of valuable machinery at slow speeds (see Table 1 for representative bridge crane speeds) with long idle periods between lifts is required. Rated loads may be handled for initial installation of machinery and for infrequent maintenance.

Class A2 (Infrequent Use) —These cranes will be used in installations such as small maintenance shops, pump rooms, testing laboratories, and similar operations where loads are relatively light, speeds are slow, and a low degree of control

accuracy is required. The loads may vary anywhere from no load to full rated load with a frequency of a few lifts per day or month.

Class B (Light Service) —This service covers cranes such as used in repair shops, light assembly operations, service buildings, light warehousing, etc., where service requirements are light and speed is slow. Loads may vary from no load to full rated load with an average load of 50% of rated load with 2 to 5 lifts per hour, averaging 15 ft, not over 50% of the lifts at rated load.

Class C (Moderate Service) —This service covers cranes such as used in machine shops, paper mill machine rooms, etc., where the service requirements are medium. In this type of service the crane will handle loads which average

Table 1. Representative Bridge Crane Speeds, ft/min. (Ref. 7)

Capacity (tons)	Slow	Medium	Fast
10	200	300	400
50	200	250	300
100	100	150	200
150	100	125	150
200	100	125	150
250	100	125	150

50% of the rated load with 5 to 10 lifts per hour, averaging 15 ft, not over 50% of the lifts at rated load.

Class D (Heavy Duty) —This service covers cranes, usually cab operated, such as are used in heavy machine shops, foundries, fabricating plants, steel warehouses, lumber mills, etc., and standard duty bucket and magnet operation, where heavy duty production is required but with no specific cycle of operation. Loads approaching 50% of the rated load will be handled constantly during the working period. High speeds are desirable for this type of service with 10 to 20 lifts per hour averaging 15 ft, not over 65% of the lifts at rated load.

Class E (Severe Duty Cycle Service) —This type of service requires a heavy duty crane capable of handling the rated load continuously, at high speed, in repetition throughout a stated period per day, in a predetermined cycle of operation. Applications include magnet, bucket, magnet-bucket combinations of cranes for scrap yards, cement mills, lumber mills, fertilizer plants, etc., with 20 or more lifts per hour at rated load. The complete cycle of operation should be specified.

Class F (Steel Mill, AISE Specification) —Cranes in this class are covered by the current issue of The Association of Iron and Steel Engineers' Standard No. 6 (rev. 1969), *Specification for Electric Overhead Traveling Cranes for Steel Mill Service*.⁵ (The AISE is currently revising this standard, now referred to as Technical Report No. 6, which will include a scale of crane classifications ranging from D1 through D9. This report will probably be available within the coming year.)

CRANE RUNWAY DESIGN CONSIDERATIONS

In examining the performance histories of existing crane runways, it is interesting to note why they have or have not performed well. Several things become apparent. Some design aspects permitted on light crane runs should not be attempted on heavy crane runs; cranes with long bridge spans (over 50 ft) should be treated differently than those with shorter spans; fast, heavy service cranes require special considerations not required for slower, lighter cranes, etc. There are several conflicting schools of thought on certain aspects of runway design over which engineers have argued for years, such as hook bolts vs. clamps, tight clamps vs. floating clamps, stepped columns vs. separate crane columns, etc. Sometimes it happens that for a certain set of conditions both parties may be correct, but one solution may have an economic advantage whereas another might provide greater longevity. The client often has a difficult choice to make.

The important thing to remember is that, due to the large range of crane sizes and uses, it is virtually impossible to establish a single set of rules applicable to all. History has dealt harshly with those who blindly follow rules. Wars have been lost, catastrophes have struck, and crane runways

have "beat themselves to death," because someone did not consider the factors from which the rule evolved and did not adjust the rule to compensate for a changing set of factors.

Loading Considerations —The following loading considerations must be taken under advisement by the designer:

1. Maximum wheel load and wheel spacing.
2. The effects of multiple cranes in the same aisle or in adjacent aisles.
3. Impact.
4. Traction and braking forces.
5. Impact forces on crane stops.
6. Cyclical loading and the effects of fatigue.
7. Lateral horizontal loads.

Many variations of single and multiple crane loadings are possible. It is better left to the designer's judgment and experience to determine what is most suitable for the particular set of parameters from which he must mold his design.

Fisher and Buettner,² pp. 59 through 66, is an excellent reference for various loading conditions and combinations, as is AISE Technical Report No. 13.³

During preliminary design studies, the specific crane information necessary for the final design may not be available. It is often necessary to estimate loadings. Table 2, taken from Merritt's *Structural Steel Designers' Handbook*,⁶ p. 6-18, is helpful. When the crane information does become available, it should be carefully compared to the estimated loadings and adjustments made to the preliminary design as required.

Miscellaneous Considerations —The designer must consider the manner in which the crane runway attaches to the main structure. The runway girder flexes as it is stressed and means of connecting must be devised to minimize the transfer of this motion into the main part of the structure. However successful the connection may be, it must be assumed that a structure with a crane will receive more motion than one without, and the design of the other building components must be implemented with this in mind.

Occasionally a crane runway may extend beyond a building to service an outside area. Figure 2 shows several typical runway profiles commonly used.

Fabrication and construction tolerances also enter into crane runway design, and provisions must be made in the various components for vertical and horizontal alignment. Adjustments must be provided for such things as inaccuracies in foundation work, deviations in column plumbness, mill tolerances of rolled shapes, sweep in crane beams, and fabrication tolerances in the crane itself.

Crane manufacturers supply clearance data for their products. The clearance area must be clear of *everything*: gusset plates, connection angles, bolt or rivet projections,

Table 2. Assumed Minimum Load for Light to Medium Cranes (Ref. 6)

Capacity (tons)	Span c. to c. rails (ft)	Wheel base (ft)	Load at each wheel (kips)	Required*** clearance		Rail** weight (lb per yd)
				Vertical (ft)*	Side (in.)	
5	40	8.5	13	6	10	30
	60	9.0	15			
10	40	9.0	19	6	10	40
	60	9.5	21			
15	40	9.5	25	7	12	60
	60	10.0	29			
20	40	10.0	33	7	12	60
	60	10.5	36			
25	40	10.0	40	8	12	60
	60	10.5	44			
30	40	10.5	48	8	12	60
	60	11.0	52			
40	40	11.0	64	9	14	60
	60	12.0	70			
50	40	11.0	72	9	14	80
	60	12.0	80			
60	40	13.0	88	9	16	80
	60	14.0	94			

* Low headroom cranes are available; consult manufacturer.

** Also see Table 3.

*** With reference to top of rail.

roof trusses or rafters deflecting under full load, sagging horizontal roof bracing, pipes, conduits, and *all else*. Infringing on the clearance space in order to gain a few inches of hook height is poor policy, especially if it shuts down a crane operation after every heavy snow storm.

It has previously been mentioned that the crane characteristics govern other aspects of the runway design. Some of these characteristics are:

1. Hook capacity (amount of lifted load including lifting devices).
2. Crane weight.
3. Hoist and trolley weight.
4. Crane clearance and hook height.
5. Class of service.
6. Speed of travel, rates of acceleration and braking.
7. Span (center to center distance of rails).
8. Number of wheels and their spacing.
9. Maximum wheel load.
10. Type and location of collector rails (or other power source).
11. Size of runway rail.
12. Length of compression stroke of the bumper device.
13. Height of bumper above the top of the crane rail.

The hook capacity, crane weight, trolley and hoist weight, and lateral hook range determine the vertical wheel loads which are delivered to the runway via the crane rails. These wheel loads are included in the information which the

crane manufacturer furnishes with his product. However, sometimes this information is required before a crane manufacturer is selected. Table 3 will be helpful as a general guide in selecting rail size.

RAILS

Rails are identified by initials and weight in pounds per *yard*. Rails are available in 30, 33 or 39 ft lengths, depending on size and manufacturer. Table 4 lists most of the common crane rail sizes.

The size of the crane rail is determined by wheel loads, type, and class of service. The crane manufacturer usually indicates the rail size for a new installation. If a new crane is purchased for an existing crane run, the crane manufacturer will supply wheels to match the existing rail, if the rail is of adequate size and configuration.

In addition to the direct load of the wheel, rails are subject to lateral forces due to horizontal hoist movement, mishandling of loads, skewing of the bridge, misalignment of the rails, and seismic influences. Crane bridges with long spans (over 50 ft c. to c. of rails) have a greater tendency to skew due to deformation of the bridge structure. Skewing accelerates wheel and rail wear and requires the use of more electric power. Longitudinal stresses in rails exist due to temperature differential, traction and braking, stretching in the area directly above the junction of adjacent deflected crane beams, and, in some cases, the impact of the crane bridge hitting rail-mounted wheel stops (one reason to avoid

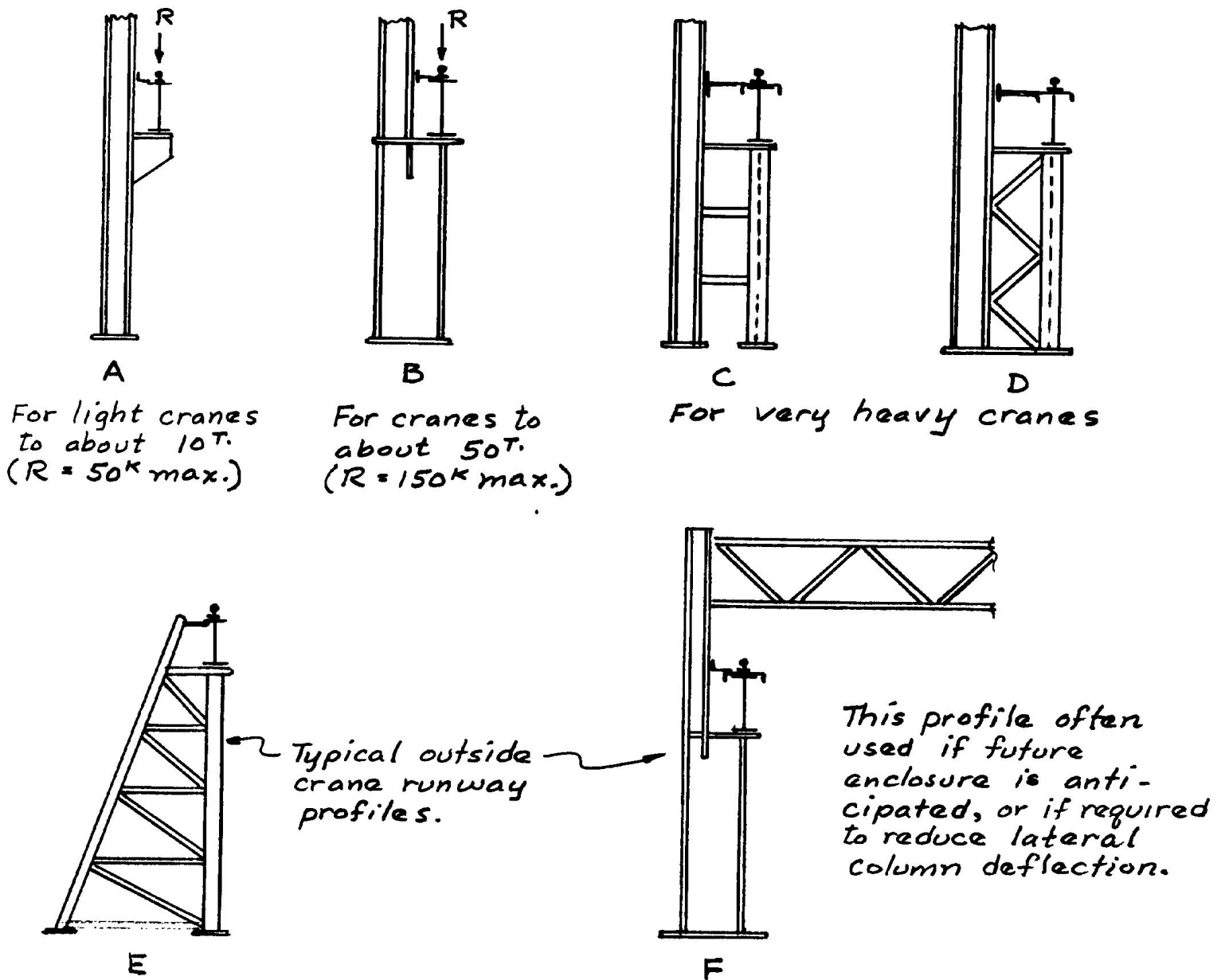

Fig. 2. Typical crane runway profiles

the use of this type of stop). Also, if rail splices are allowed to "open up" so that gaps exist, the rail ends are subject to a hammering action from the wheels, which can result in peening or chipping of the rail ends and may also inflict damage or speed the wear on the wheels.

Rails are generally spliced either by bolting or welding. The most common choice is bolting. Bolted splices are simple to install and relatively easy to dismantle if rails must be replaced or realigned. Welded splices provide a relatively smooth running surface if made properly, but require expensive preparation and welding techniques and make it difficult to repair or replace rails if the need arises. An example of a welded splice being justified might be where it is desired to have a very smooth running Class A1 crane on a

short runway, with the life of the rail anticipated to outlast the life of the structure.

Rails for heavy service cranes (Class D, E, and F) should have tight splice joints and these rails should be ordered with milled ends and the splice bars should be indicated for a "tight fit." The size range for these rails is usually 104# and above. If requested, the rail manufacturer will drill the rails for the splice bar holes and also for hook bolts if that method of rail attachment is specified. The *Whiting Crane Handbook*⁷ and the *AISC Manual*² recommend that, when ordering rails for use on crane runways, the order be noted "for crane service." However, two major rail manufacturers state that the phrase "for crane service" will net the purchaser a "control cooled" rail. A "control cooled" rail has

Table 3. Allowable Loads on Rails (lbs) (Ref. 7)

CMAA Service Class	Wheel diam. (D) in.	ASCE 30#	ASCE 40#	ARA-A 90#	ASCE 60 & 70#	ASCE 80 & 85# Beth 104# USS 105#	ASCE 100#	AISE 135#	AISE 175#	Beth 171#
Class A1 & A2:	8	13610	16000							
Power House & Infrequent Service	9	15310	18000	23900	25200					
Class B:	10	17010	20000	26600	28000					
Light Service	12	20410	24000	31900	33600	36000	40800			
Class C:	15	25510	30000	39800	42000	45000	51000			
Moderate Service	18	30610	36000	47800	50400	54000	61200			
P = 1600 WD	21		42000	55800	58800	63000	71400	75600	105000	117600
	24			63800	67200	72000	81600	86400	120000	134400
	27					81000	91800	97200	135000	151200
	30					90000	102000	108000	150000	168000
	36						125000	130000	180000	202000
Class D:	8	11900	14000							
Heavy Duty Service	9	13390	15750	20900	22050					
P = 1400 WD	10	14880	17500	23200	24500					
	12	17860	21000	27900	29400	31500	35700			
	15	22320	26250	34900	36750	39380	44630			
	18	26790	31500	41800	44100	47250	53550			
	21		36750	48800	51450	55130	62480	66150	91880	102900
	24			55800	58800	63000	71400	75600	105000	117600
	27					70880	80330	85050	118130	132300
	30					78750	89250	94500	131250	147000
	36						107200	113600	157800	176500
Class E:	8	10200	12000							
Severe Duty-Cycle Service	9	11480	13500	17900	18900					
P = 1200 WD	10	12760	15000	19900	21000					
	12	15310	18000	23900	25200	27000	30600			
	15	19130	22500	29900	31500	33750	38250			
	18	22960	27000	35900	37800	40500	45900			
	21		31500	41800	44100	47250	53550	56700	78750	88200
	24			47800	50400	54000	61200	64800	90000	100800
	27					60750	68850	72900	101250	113400
	30					67500	76500	81000	112500	126000
	36						92000	97300	135000	151000

Notes: The loading limits for Class E are also recommended wherever travel speeds exceed 400 fpm.

W = effective width of rail head

D = diameter of wheels

a Brinell Hardness range of about 240 to 280. A "heat treated" rail has a Brinell Hardness range of about 321 thru 388. "Heat treated" rails will accept wheel loads about 20% greater than "control cooled" rails. An alternative to these two types of rails is to order the rails "control cooled" and with "ends hardened" (or "ends quenched"). Hardening the ends of the rails provides protection where the wear and abuse is likely to be the greatest. *Rails for heavy service cranes should be ordered "heat treated."*

If rails and splice bars are not ordered for a "tight fit," the splice will generally have a small gap in the order of 1/16-in. to 1/8-in. The rail ends are sheared or sawed and then "dressed up" to varying degrees. These are suitable only for light service (Class A2, B) cranes operating at relatively

low speeds. Plain unpunched rails are also available from rail manufacturers if custom fabrication such as special punching and/or end finishing is required.

Splice bars should be ordered from the same source as the rails so that the holes will properly line up. Splice bars are ordered in pairs and include the bolts, lock washers, and nuts (or lock nuts). The AISC Manual,¹ pp. 1-106 and 1-107, contains general information on rails and rail splices, but the catalogue of specific rail manufacturers should be consulted before ordering.

Rail joints on one side of a crane runway should be staggered so that they do not line up with those on the opposite

Table 4. Rail Sizes and Dimensions ⁷

Type & weight per yard	A (in.)	B (in.)	C (in.)	Sect Mod. (in. ³)
ASCE 25	2¾	2¾	1½	1.76
ASCE 30	3⅝	3⅝	1⅞	2.5
ASCE 40	3½	3½	1⅞	3.6
ASCE 60	4¼	4¼	2⅝	6.6
ASCE 70	4⅝	4⅝	2⅞	8.2
ASCE 80	5	5	2½	10.1
ASCE 100	5¾	5¾	2¾	14.6
Beth 104	5	5	2½	10.7
USS 105	5⅜	5⅜	2⅞	12.4
AISE 135*	5¾	5⅜	3⅞	17.2
AISE 175*	6	6	4¼	23.3
Beth 171	6	6	4⅝	24.5

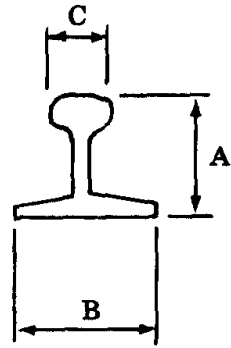

* Also known as USS 135, Beth 135, USS 175, Beth 175.

side. The amount of the stagger should be at least 1 ft, and should *not* be the same as the spacing of the crane wheels. Never locate a rail splice near a crane beam splice. Do not use pieces of rail shorter than approximately 10 ft if avoidable.

There are three methods of attaching rails to the supporting members:

1. Hook bolts
2. Clamps
3. Welding (not recommended)

Hook bolts are satisfactory for fastening the rails for slow moving cranes of Class A2 or B service where the capacity is not over approximately 5 tons and the bridge span is under about 50 ft. Properly made hook bolts provide good adjustment and hold down forces for these light service installations. They can be used for wide-flange crane beams

and also those with channel caps (see Fig. 3), and they are useful on beams with flanges too narrow for clamps. Hook bolts are installed alternately in pairs, each bolt about 3 or 4 in. apart and each pair about 2 ft apart. Hook bolts do have a tendency to loosen up, even though they are installed with lock washers or lock nuts. Broken hook bolts sometimes result if they were not properly heated during their manufacture.

Clamp plates are a more positive method of attachment and there are several types in common use: steel plates with fillers, and steel forgings in many patterns with single- and two-hole versions. There are also several ingenious patented rail clamp devices now available on the market. Clamps are available in either fixed or floating types (Fig. 3). A "fixed" clamp holds the rail tightly to the supporting member, with alignment being accomplished through eccentric punching of the filler plates. A "floating" clamp permits controlled longitudinal and transverse rail movement. Adjustment is by means of eccentrically punched fillers the same as with "fixed" clamps. Clamps should be spaced 2 to 3 ft apart on each side of the rail and may be installed in opposing pairs or staggered.

Single-hole clamps should be avoided. Although most are designed not to rotate, they have been known to do exactly this, resulting in a camming action which tends to force and keep the rails out of alignment. Two-hole clamps do not have this problem and should be used on all but the most insignificant crane system.

The decision of whether to specify a "fixed" or "floating" rail system is one which has been argued hotly for many years. Both have been used successfully and both have been accused of causing problems. AISE Technical Report No. 13³ recommends "floating" rails. (It should be mentioned that the AISE places emphasis on heavy service steel mill cranes.) Crane manufacturers generally prefer "fixed" rails. The AISC is neutral.

A "floating" rail is harder on rail splices which are not ordered for a "tight fit." In time the splices tend to open up due to thermal contraction and longitudinal, braking and

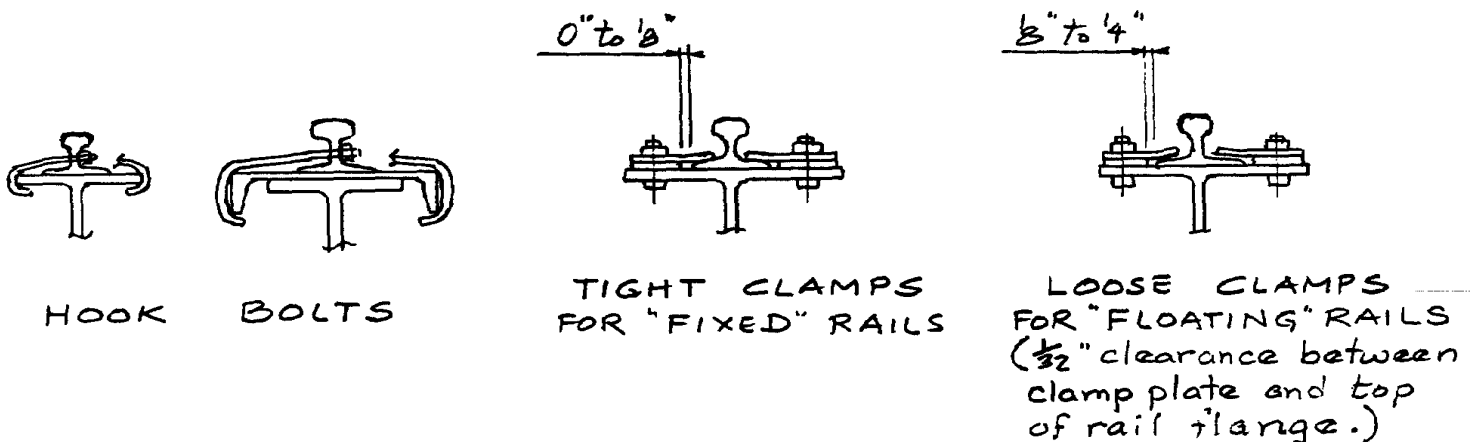

Figure 3

traction loads (similar to a string of boxcars leaving a railroad yard). The movement is almost imperceptible, but in time can wear grooves in the supporting crane beam. Grooving is most prevalent in outside runways. The deeper the grooves the sloppier the rail becomes and the problems associated with misalignment become more frequent. This can lead to the requirement that a wear plate be installed beneath the rail.

If a steel wear plate is utilized it should preferably be made easily replaceable, that is, attached by bolting. Often a channel cap can be utilized for a wearing surface and replaced when the amount of wear becomes objectionable. This loss of section should be considered when determining the channel size. Some wear plates are limited to a width equal to the base width of the rail. This requires extra fills under the clamp plates to compensate for the wear plate thickness. This type of wear plate requires occasional checking to see that the "creep" is taking place between the rail and wear plate, as it should and usually does, and not between the bottom of the wear plate and the girder top.

If a quiet, vibration-free crane service is required, fiber pads can be used below the rails. These are not recommended for a "floating" rail system unless a scheme is devised to keep the pads from working their way out from under the rails.

To address the problem of excessive rail "creep," at some installations the owners have tried welding the clamp plates to the rails for a short distance about mid-way of the crane runway length to provide an "anchor zone," thus reducing the amount of creep. This of course prevents future adjustments and may induce forces of unknown magnitude in those crane beams in the anchored areas. Caution, laced with apprehension, should be used when welding *any* rail to its supporting member. The AISC Manual,¹ p. 1-106, also has negative thoughts on the topic of welding rail, and this is good advice.

"Floating" rails on outside crane runs exposed to the weather seem to wear faster, probably because water is held beneath the rail by capillary action and tends to rust between periods of use. However, "floating" rails are sometimes preferred on exterior crane runways which are supported on isolated bents (such as sketch E in Fig. 2), due to the difficulty in keeping this type of runway in horizontal alignment.

We have mentioned several disadvantages with "floating" rails. What are the advantages? "Floating" rails do allow for thermal and other longitudinal movement. (It is generally conceded that building an expansion joint into a rail does not warrant the expense.) However, for crane runways over 400-ft long, the crane runway *beams* usually *do* require an expansion joint and the use of a "floating" rail system is advised in this case. For cranes classified for "heavy service" (CMAA Classes D, E, and F), it is advisable to use "floating" rails in order to minimize wear on the rails, wheels, and wheel bearings. Also, "floating" rails should be used if rail splices are ordered for a "tight fit." In general,

this will encompass 104# rails and heavier for the above CMAA Classes.

"Fixed" rails do not have the drawbacks of "floating" rails nor do they have the advantages. However, unless there is a reason for using a "floating" rail the nod should go to a "fixed" rail. Most rail installations today are of the "fixed" variety, mainly because there are many more light to medium cranes in service today than there are heavy cranes, and for most of these moderate size cranes a "fixed" rail is suitable and proper.

Fastening a rail to its supporting member by welding is rare and should be avoided unless circumstances dictate otherwise. Once welded, a rail cannot be realigned if the building shifts or settles, and replacement is very difficult. Welding the rail to the crane beam may cause cracking due to the fatigue stresses.

Rail clamps and hook bolts are shown on p. 1-108 of the AISC Manual.¹

The current *Whiting Crane Handbook, 4th Edition*,⁷ gives the following tolerances for rail alignment: span dimension (c. to c. rails) $\pm\frac{1}{8}$ -in., elevation of rails at points opposite each other $\pm\frac{1}{8}$ -in., elevation of a rail within the length of the wheelbase $\pm\frac{1}{8}$ -in. These figures may seem a bit idealistic, but will none-the-less help to attain a smooth running and problem-free crane system. In actual field conditions the matchup of wheel to rail and certain types of wheel bearings allow for lateral wheel "float" which will usually accommodate a larger tolerance than 1/6-in. A more realistic span tolerance might be $\pm\frac{1}{4}$ -in. for spans up to 100 ft and $\pm 5/16$ -in. for spans 100 ft and over, as given in the *3rd Edition* of the *Whiting Crane Handbook*. Runway elevations are subject to greater deviations due to differential settlements of the foundations, especially in long runways which may cover several areas of varied foundation conditions. It is advisable, as we shall see a little later on, to have some means of vertically adjusting the crane runway beams. The magnitude of vertical tolerance allowed is often dependent on what the individual crane can tolerate, and this varies from crane to crane—some being very stiff and others quite limber.

AISE Technical Report No. 13³ gives the following crane runway tolerances:

Maximum sweep in crane runway girders $\frac{1}{4}$ -in. per 50-ft length of girder span. Camber not to exceed $\frac{1}{4}$ -in. per 50-ft length of girder span over that indicated on the design drawings. Center-to-center of crane rails not to exceed $\frac{1}{4}$ -in. from theoretical dimension. Horizontal misalignment of crane rails not to exceed $\frac{1}{4}$ -in. per 50-ft length of runway with a maximum of $\frac{1}{2}$ -in. total deviation from the theoretical location. Vertical misalignment of crane rails measured at the center lines of columns shall not exceed $\frac{1}{4}$ -in. per 50-ft length of runway, with a maximum total deviation of $\frac{1}{2}$ -in. from the theoretical location. Crane rails shall be centered on the crane girders wherever possible, but in no case should the eccentricity be greater than three-fourths the thickness of the girder webs.

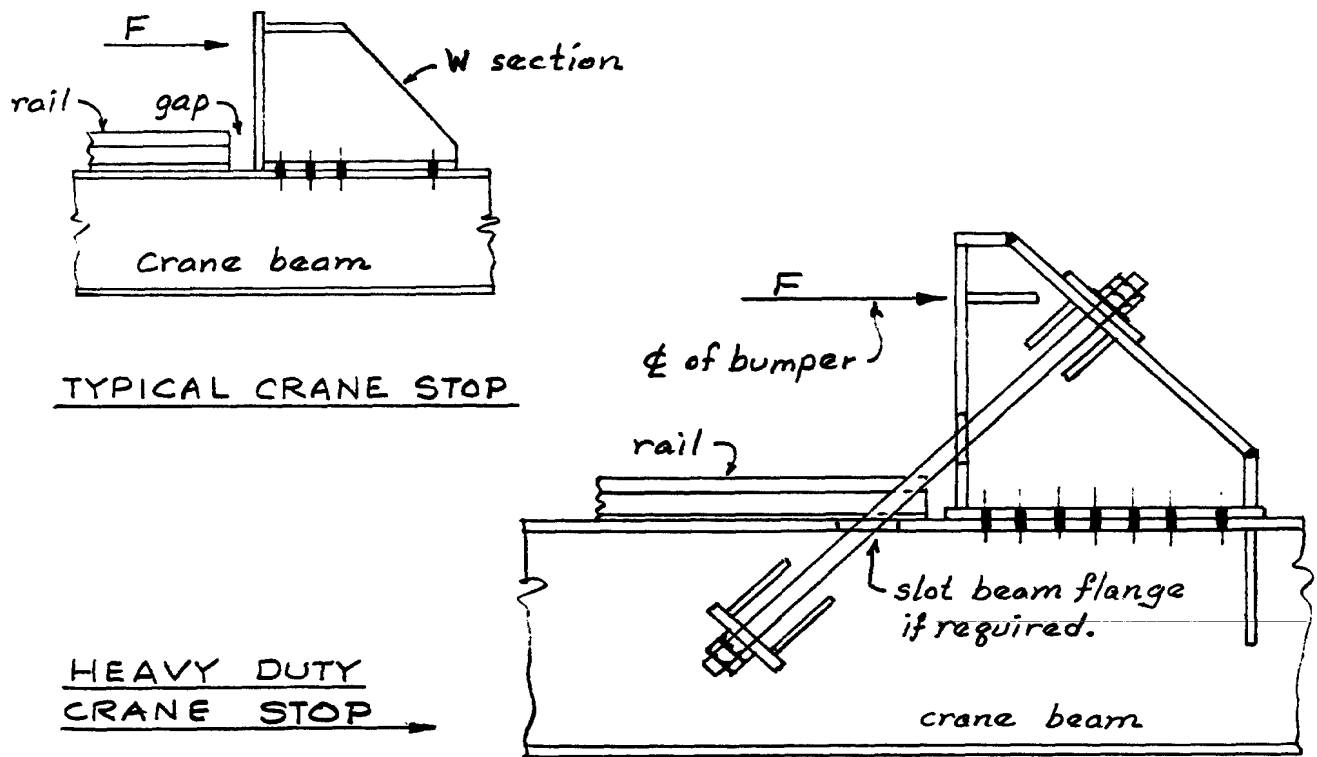

Figure 4

These AISE tolerances seem practical and within the scope of the real world of fabrication and erection.

CRANE STOPS

Crane stops prevent the crane from falling off the end of a runway. They can also be mounted at any location along a runway to keep a crane from advancing beyond that point. This type of crane stop preferably should straddle the rail and connect to the beam, although trolley stops can be used for very light cranes. Crane stops are mounted directly on top of the crane girders. (See Fig. 4.) They should not be confused with trolley stops (or wheel stops) which are attached directly to the crane rail by bolting through the web of the rail. Trolley stops should only be used for the very lightest and slow moving cranes, as they are prone to inflict damage on the wheel bearings.

Figure 4 shows a typical crane stop and a heavy duty stop. Any workable combination of shapes and plates can be used to construct a crane stop. A gap should be provided between the end of the rail and the face of the stop to accommodate expansion and "creep." Allow about 1 in. for each 100 ft of rail, with a maximum of 4 in. The height of the crane stop should be made to suit the height of the crane bumper—generally about 1 ft-6 in. to 2 ft-6 in. above the top of the rail. The crane bumpers are mounted on the bridge

trucks directly in line with the center of each rail. Most modern cranes have bumpers which have some energy absorbing feature, such as rubber padding, springs, or hydraulic or pneumatic cylinders. These absorb some of the shock and are less abusive to the runway structure and the crane itself.

Crane stops are commonly used to realign (square up) the crane bridge in respect to the runway and it is important that the crane stops be in true alignment.

The crane stop must be designed to resist the impact force F shown in Fig. 4.

The following formula is used to compute the approximate force F , in kips, at each stop for cranes with energy absorbing springs or cylinders:

$$F = \frac{WV^2}{2gT}$$

where

W = total weight of crane, in kips, *excluding* the lifted load

V = crane speed in ft/second. The value of V is taken as 50% of the full load rated speed according to AISE Technical Report No. 6.⁵ (See Table 1, which gives velocity in ft per *minute*.)

g = acceleration of gravity = 32.2 fps²

T = length of travel, in ft, of spring or plunger required to stop crane, usually about 0.15 ft.

The *Whiting Crane Handbook*⁷ suggests a value of 40% of the rated load bridge speed in accordance with ANSI Standard B30. Take your choice. The real problem in the above formula is the dimension T . This dimension is not listed in the *Whiting Crane Handbook* and it is doubtful that an engineer could obtain this dimension at the time he is doing his design unless he knows exactly the crane being purchased.

The above formula assumes that each stop shares the load equally (that the resultant inertia force due to the weight of bridge and trolley is located at midspan). This is a common approach. If it can be determined that the resultant inertia force is appreciably off-center, then the force directed against the face of the crane stop should be increased proportionately.

Outside cranes are subject to wind forces which have caused problems over the years. Several cases have been recorded where a crane's brakes were inadequate to resist the force of the wind, causing the crane to ride through the crane stops and fall to the ground. Once, this wind force was estimated by calculating the vertical projected area of the crane and multiplying by a force of about 10 psf. Today, the process is a bit more complicated. Refer to pgs. 92 and 93 of the *Whiting Crane Handbook*,⁷ wherein a method of calculating wind pressure is explained based on ANSI recommendations.

When reviewing your calculations for the impact load on a crane stop, it is well to add a good pinch of common sense and judgment.

CRANE BEAMS

The work horse of the crane runway is the crane beam or crane girder or, in some special cases, the crane truss. The crane beam is subject to vertical loading including impact, lateral loading, and longitudinal loading from traction, braking, and impact on crane stops. In addition the crane beams must withstand local buckling under the wheel loads and at the bottom flange over the column (in the common case where the beam bears on a column cap plate).

In this discussion the terms crane beam and crane girder will be considered synonymous and refer to a horizontal load-carrying member, not necessarily a wide-flange section as opposed to a plate girder.

Figure 5 shows several common profiles for crane beams.

The profiles in Fig. 5 can be combined with other shapes to form horizontal trusses and walkways (See Fig. 6.) Observe all appropriate safety codes and considerations when utilizing horizontal surfaces as walkways or platforms.

Simple span crane beams are desirable. Two-span crane beams have dubious benefits. The initial modest cost saving due to the lesser weight of a two-span girder is usually

negated by greater labor costs and the inevitable costly maintenance required. The effect of fatigue and prolonged reversal of stress takes its toll on this and other members in the structure. Two-span crane beams can result in uplift on columns at certain loading positions, and differential settlement of columns may result in undesirable additional stresses. A two-span girder makes reinforcement or replacement of the crane beam more complicated and costly. Perhaps the greatest advantage of a two-span girder is the slightly reduced deflection and end rotation.

Crane beams should be designed elastically, *not* plastically. Avoid abrupt changes in cross sections of crane girders.

Crane girders or trusses over approximately 75 ft in length should be cambered for the deflection due to dead load plus one-half the live load without impact.⁶ The dead load consists of the weight of the girder or truss. The live load consists of that maximum load delivered to the girder or truss by the crane wheels, exclusive of impact.

Avoid cantilevered crane beams if possible.

In order to gain more stiffness, use ASTM A36 steel for crane beams. If, for any reason, higher strength steel is used, the deflection should be investigated.

Which brings us to a very important subject. The major cause of problems in crane runs is the deflection of crane beams and the accompanying end rotation. This troublesome characteristic transmits motion to other components of the crane runway. The cyclical nature of this movement causes fatigue stresses which may lead to weakening and eventual failure of the parts affected. Stretching of rails, opening of splice joints, column bending, skewing of the crane bridge, and undulating crane motion are among the undesirable side effects.

One of the engineer's principal objectives in the design of a crane runway is to limit the vertical deflection of the crane beam. Many of the most successful crane runways owe their performance record to the fact that someone had the foresight to limit the deflection, although other factors sometimes get the credit. In general, keep the spans as short as possible and the beam depths as large as possible. The design profession is not in total agreement as to the degree of stiffness which is desirable in a crane beam. The following is a brief sampling:

Source	Maximum Vertical Deflection(in.)
Fisher & Buettner ²	$L/600$ for Light & Medium Cranes
Merritt ⁶	$L/1000$ for Mill Cranes
Gaylord & Gaylord ⁸	$L/750$
	$L/960$ for Light Slow Cranes
	$L/1200$ for Heavy Fast Cranes
AISE Technical Report 13 ³	$L/1000$

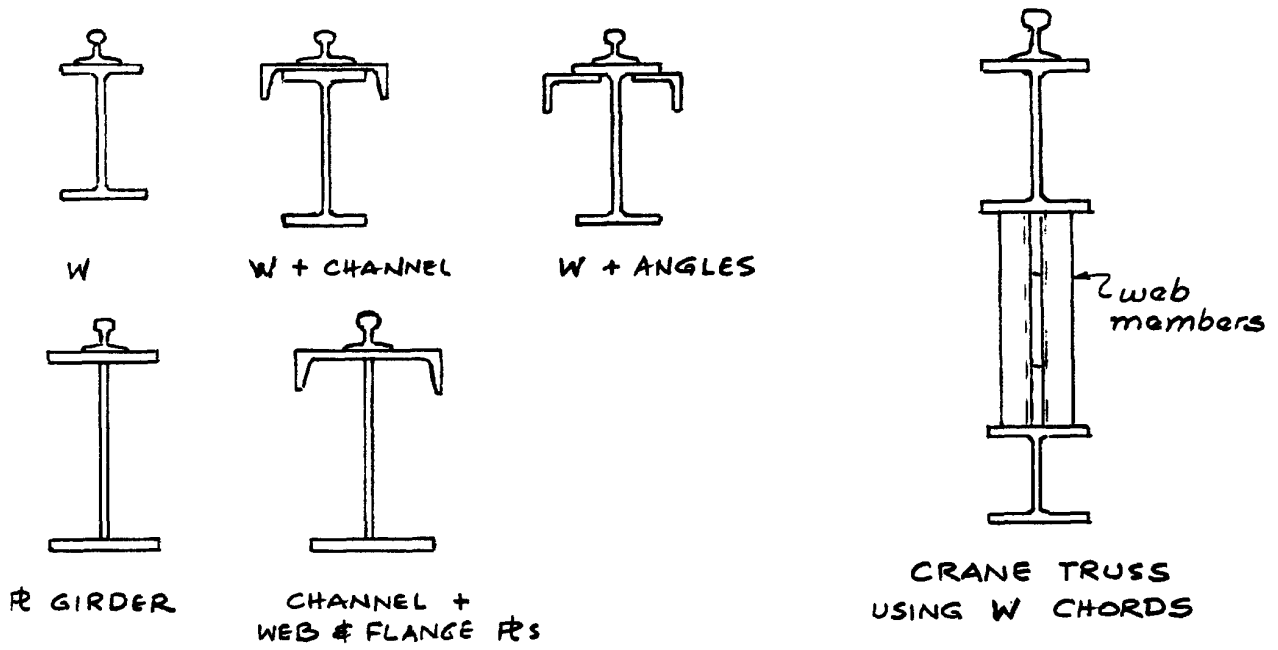

Figure 5

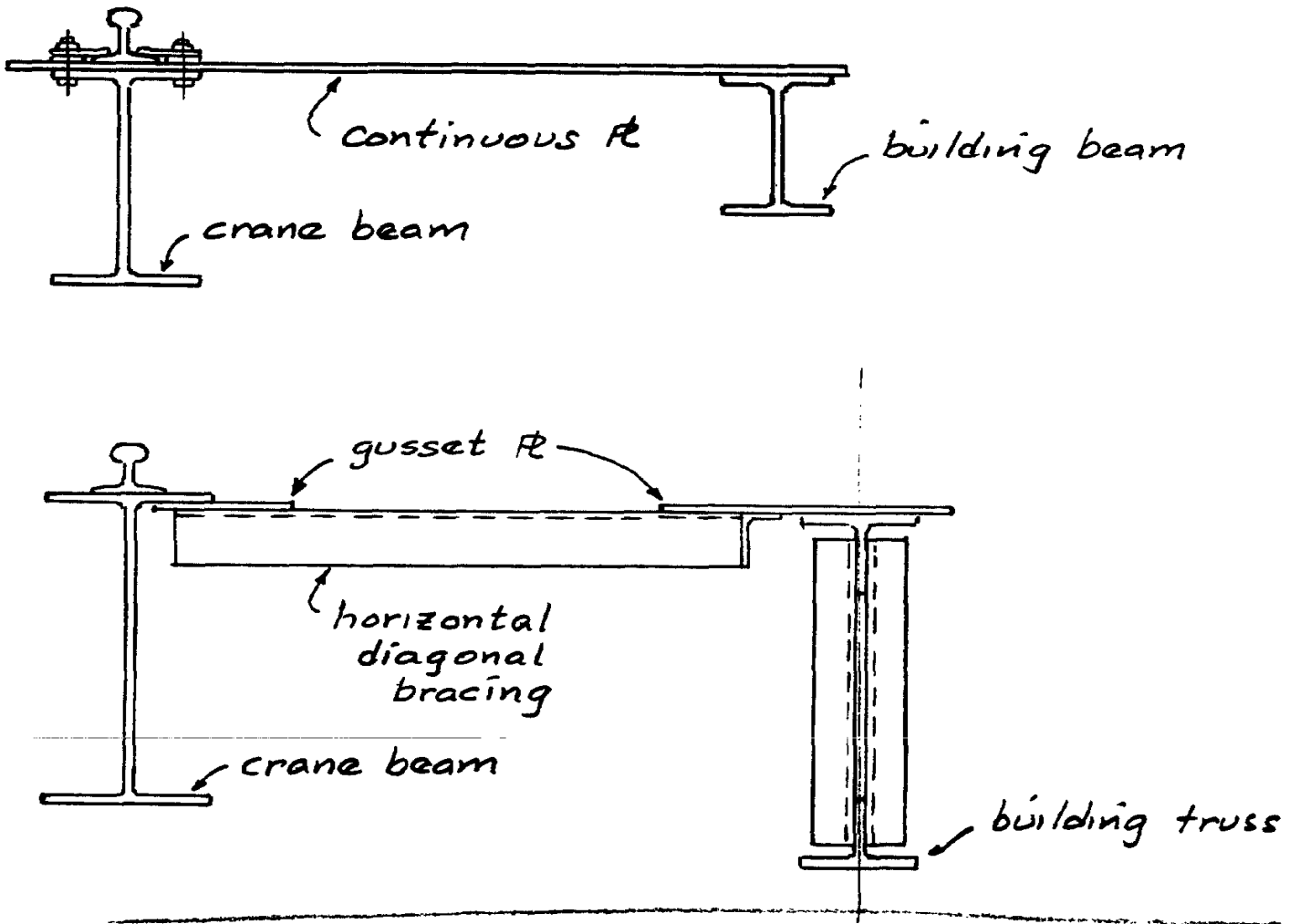

Figure 6

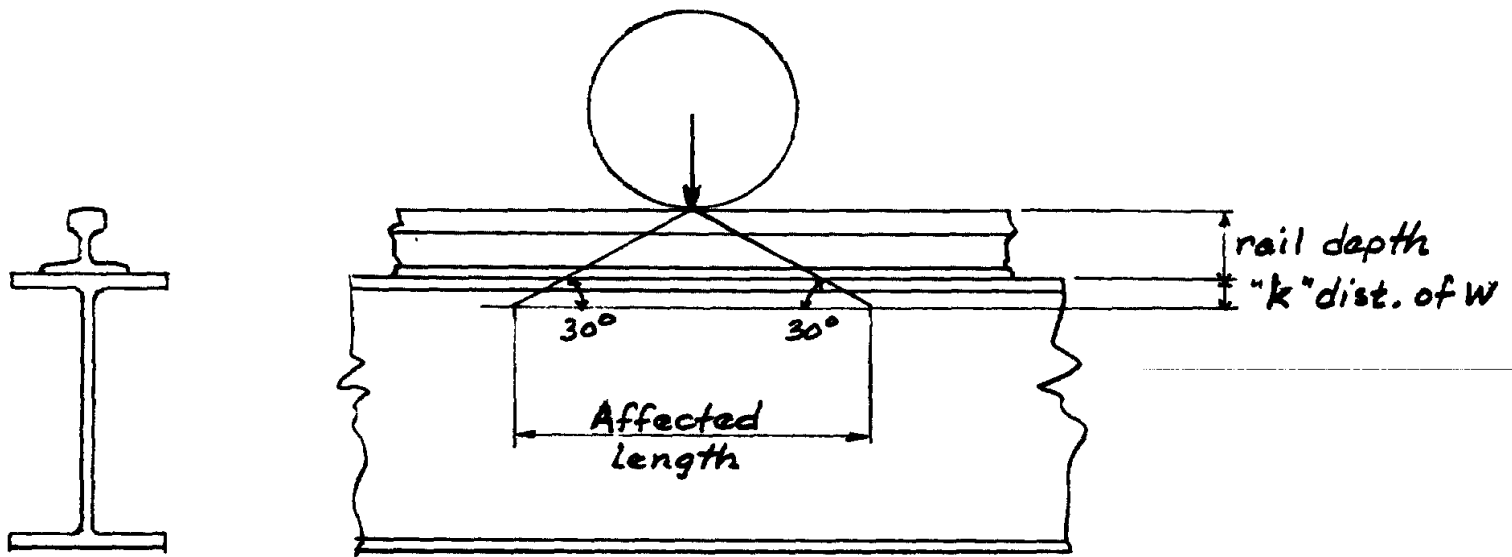

Figure 7

Having viewed the effects of many limber crane beams, this writer recommends that the maximum vertical deflections be limited to $L/1000$ for light to medium cranes and $L/1200$ for heavy cranes. It's the nicest thing you could do for your client and his crane run.

Vertical loads are delivered to the crane beam via the crane rail. The beam web must be capable of withstanding this localized load. The AISE recommends that a full penetration (groove) weld be used between the web and top flange plate of welded plate crane girders in order to maximize the fatigue life of the member.

There has been some conjecture over the years as to what length of web is affected by the concentrated wheel load. The angle of 30° shown in Fig. 7 is a logical average between the 45° pure shear angle and the 22° angle familiar in column stiffener analysis. This reflects the thinking of such notables of a generation ago as C. Earl Webb, Russell Chew, C. T. Bishop, Thomas Shield, and H. H. Shannon, as reported in an article by J. C. Arntzen.⁹ This was during the era when most girders were made up of riveted plates and angles. Using this angle of 30° , the affected length can be calculated as follows:

Affected length = $3.5 \times (\text{rail depth} + k)$. In the case of a plate girder the formula becomes: Affected length = $3.5 \times (\text{rail depth} + \text{flange thickness})$. AISE Technical Report No. 13³ recommends the more conservative 45° angle rather than the 30° suggested above, which would change the value 3.5 in the above formulas to 2. Since web crushing is hardly ever critical, we have probably used too much verbiage on the subject already.

The above formula has more significance when investigating "built-up" plate girders (girders composed of flange angles riveted to a web plate), especially those of ancient vintage. Designers in the past were not always careful to make sure that the web plate bore full length on the underside of the top cover plate. In the event that it didn't

bear, the wheel load was delivered to the web plate via the connecting rivets and the affected zone did not always contain enough rivets to withstand this load. Anyone investigating these old members should check this bearing condition carefully, often difficult for those of us not blessed with X-ray vision. In Fig. 8, the affected length formula for a riveted or bolted member becomes: affected length = $3.5 \times (\text{rail depth} + \text{cover plate thickness} + \text{angle gage})$.

The wheel load should always be increased for vertical impact when designing crane beams. The AISC Manual¹ p. 5-15, recommends 25% for cab-operated traveling cranes and 10% for hand-operated cranes. Table 5, taken from the *Whiting Crane Handbook*,⁷ gives their recommendations for runway design factors, related to classes of service.

The effects of an off-center crane rail must be considered. Excessive rail eccentricity must be avoided, as it will cause local flange bending and subject the crane beams to torsional moments. Excessive sweep in crane beams, which is a contributing factor to rail eccentricity, should be removed at the time of fabrication. The AISE suggests a limit for this eccentricity of $0.75t_w$ for both wide-flange beams and plate girders. (See Fig. 9.)

To counteract the effects of rail eccentricity, the engineer may consider the addition of intermediate stiffeners to the crane beams or girders. These should bear and be welded to the underside of the top flange and down the web with continuous welds.

Lateral forces can be caused by mishandling of loads, misalignment of the runway, crane skew, and seismic loads. For design purposes this force is considered to act at the top of the rail and perpendicular to the rail. The AISC formula for determining lateral force is as follows:

Lateral force at *each* rail = $0.10 \times (\text{lifted loads} + \text{trolley weight})$. Other organizations, notably the AISE Technical Reports 6 and 13, have similar rules, and these should be examined as the case may dictate. Also see Table 5.

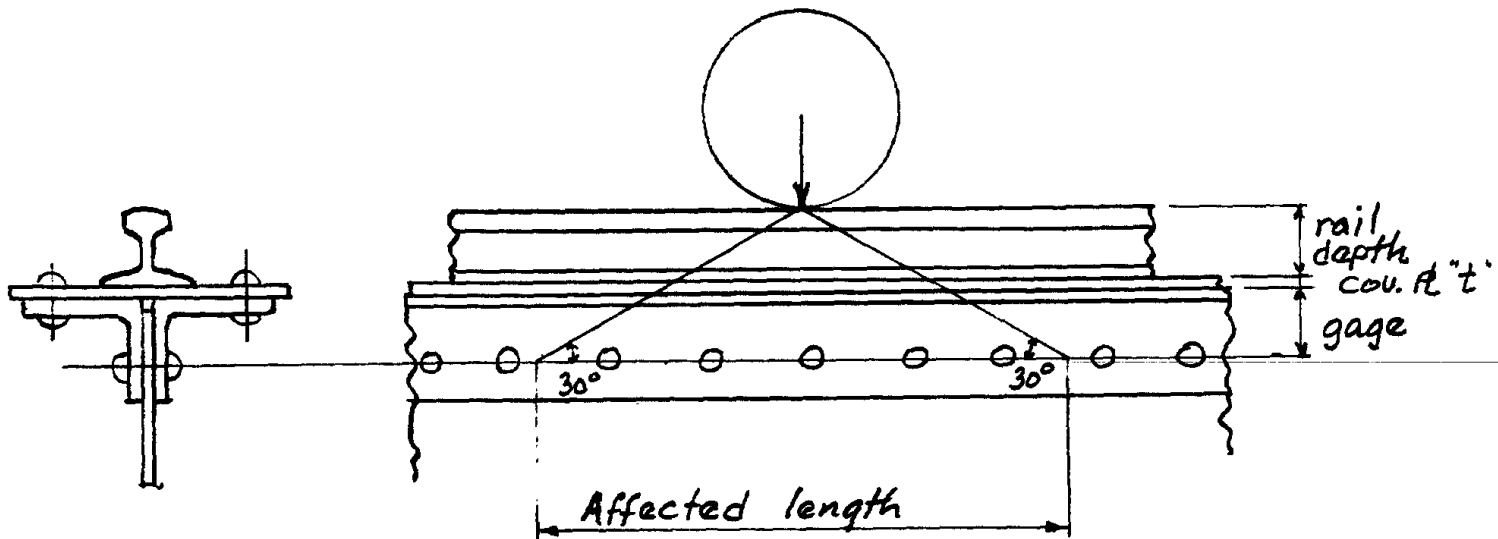

Figure 8

Lateral deflection should be limited to about $L/400$.

AISE Technical Report No. 13³ requires crane girders of over 36-ft span to have their bottom flanges stiffened by a lateral bracing system connected to an adjacent girder or stiffening truss.

When examining a crane beam for resistance to lateral loading, only the section modulus of the top flange should be considered. If the strength of the section proves to be inadequate, it can be reinforced by adding a channel, plate, or angles, or by making a horizontal truss or girder in the case of large lateral loads. (See Figs. 5 and 6.)

These reinforcing members are often attached by welding. Due to the fatigue factor associated with intermittent welding, it is wise to consider using continuous welds (AISC stress category B vs. E) for these members, even though strength alone does not warrant their use. As a general guide when selecting the type of crane beams to use, consider the following suggestions. (See Fig. 5.)

For light cranes and short spans: use wide-flange.

For medium cranes and moderate spans: use wide-flange reinforced with a channel cap or angles.

For heavy cranes and long spans: use a plate girder with adequate provision for resisting lateral forces.

For extreme spans, trusses have been used. The Crane Service Classifications described earlier in this paper should also be considered, along with judgment and experience, when determining which kind of beam to use.

Reduced allowable stresses due to cyclical loading factors must be applied to all crane runway components when applicable. Refer to AISC Manual Appendix B.

In designing crane beams which require channels, plates, or angles to resist lateral loads, a practice which simplifies design and yields conservative but uneconomical results is to consider that vertical forces are resisted only by the beam and that lateral forces are resisted only by the channel,

plates, or angles. Most designers assume the lateral load is resisted by the channel (or plates or angles) plus the top flange of the beam, and that the vertical load is resisted by the combined beam and channel (or plate or angles).

When sizing crane beams with added channels and if clamps are used to fasten the rails in place, it is necessary to select member sizes which will accept the required hole spacing. (See Fig. 10.) Threaded studs may be used in place of the bolts if a proper gage cannot be utilized.

Table 5. Runway Design Factors⁷

CMAA Service Class	Forces on Crane Runways (% of Wheel Load)		
	Vertical Impact, %	Longitudinal, %	Lateral, %*
A	10	5	10
B	10-15	5	10
C	15-25	5-10	15-20
D	25	10	20
E	25-50	10-15	20-25
F	25-50	15-20	20-30

* Given as % of rated load plus trolley weight with one half applied to each rail.

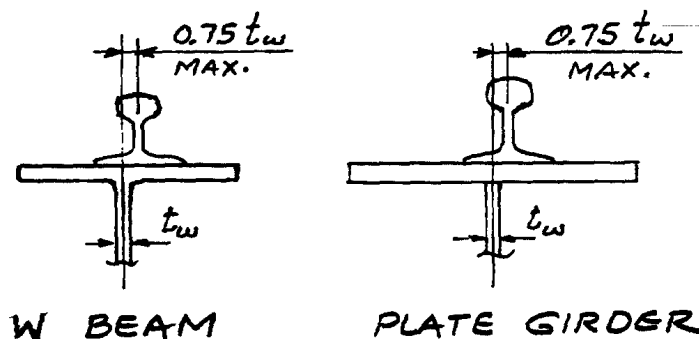

Figure 9

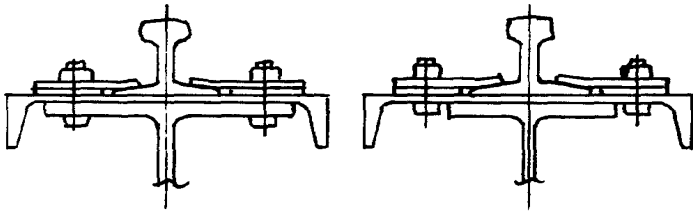

Figure 10

The fabricator of the crane girders should take precautions to see that the webs are perpendicular to the bottom flanges for a distance of about 1 ft-6 in. from each

end. This will help to prevent lateral misalignment of the tops of two crane beams which share the same column cap plate.

Longitudinal loads are also present in a crane runway due to traction, braking, impact against crane stops, and wind. For design purposes the AISC gives the following:

$$\text{Longitudinal Force} = 0.10 \times (\text{total wheel loads each rail})$$

Also see Table 5. Longitudinal forces are hardly ever critical, but their existence should not be ignored, especially when considering the connection of the crane beam to the column cap plate, and when designing the bracing and foundations.

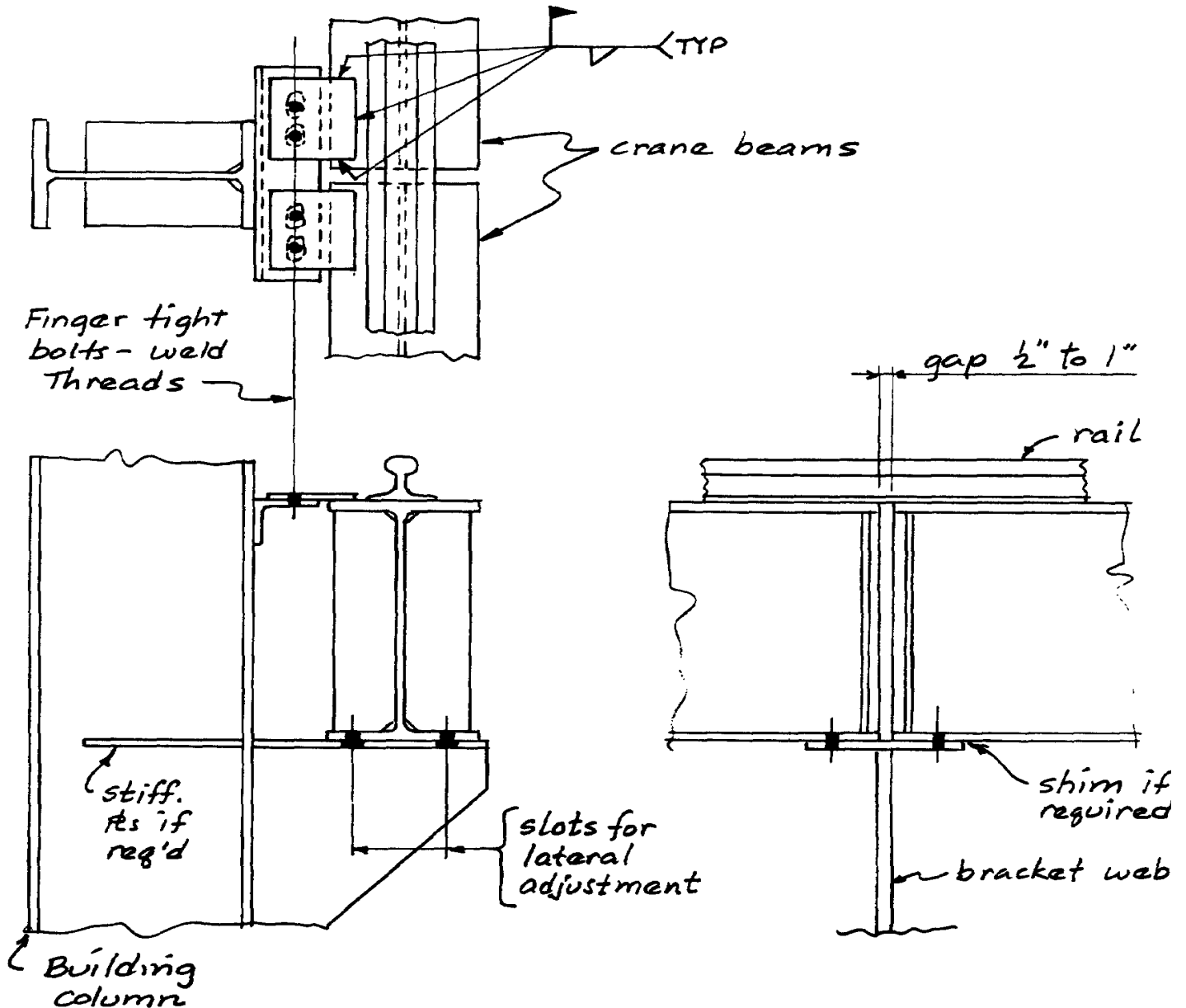

Figure 11

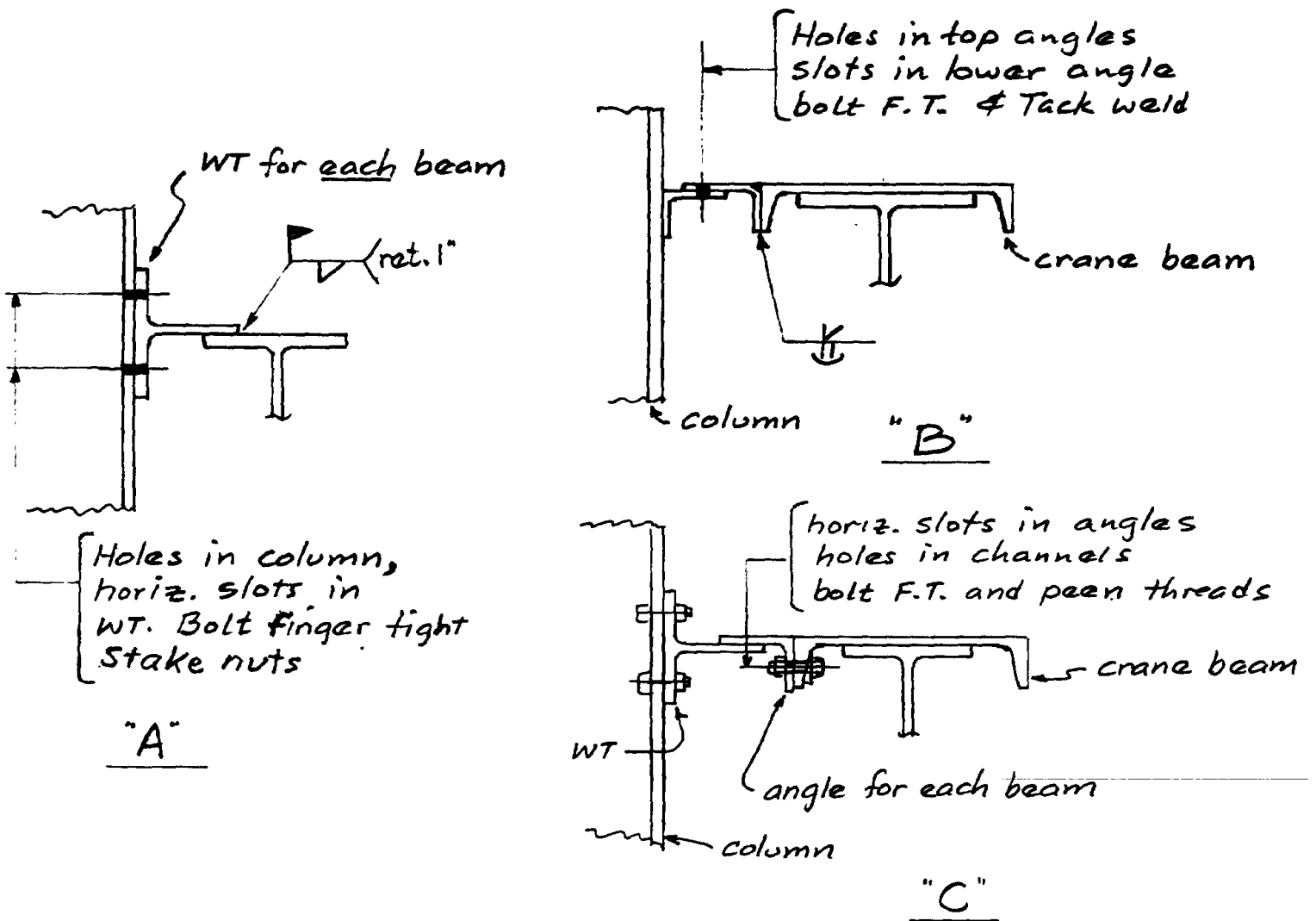

Figure 12

COLUMNS

Figure 2 shows several crane column profiles for various crane size categories.

AISE Technical Report No. 13 requires that impact be considered in crane columns when one crane is the governing criterion. The AISC does not require this. However, if the crane beam is supported on a bracket attached to a column, then impact must be considered in the design of the bracket.

Figure 11 shows a column bracket. This type of crane beam support should be limited to relatively light crane loads and light service cranes (max. reaction = 50 kips).

Slots are provided in the bracket seat plate for lateral adjustment. Stiffeners are placed at the end of the beam to prevent web buckling and to lead the reaction toward the bracket web. The bolts connecting the beam to the bracket must be adequate to resist the longitudinal forces. Note that stiffeners are *not* shown in the bracket web plate directly below the crane beam web. Omission of these stiffeners

allows the seat plate to flex with the beam end as the crane passes along the runway. But stiffeners may be required for certain other bracket configurations. The lateral forces are resisted at the top flange.

Figure 11 shows an angle, shop welded to the column flange (it could be bolted), containing longitudinal slots. The connecting plates must be individually fastened to each beam. The plates have holes and may be bolted or welded to the beams either in the shop or field. Note that the slots should be placed in the lower of the two members, so that they will not fill up with dirt or debris. The bolts at this connection should be snugged up, then backed off about 1/2 turn and the bolt peened or threads nicked or welded. To determine the number of bolts required, the bearing of the bolt against the side of the slot must be checked. If the building settles and it is necessary to raise the crane beam to relevel the runway, note that this is easily done with shims inserted between bracket and bottom flange of beam and between the angle and the plate at the top flange. Figure 12 shows other combinations of lateral load resisting

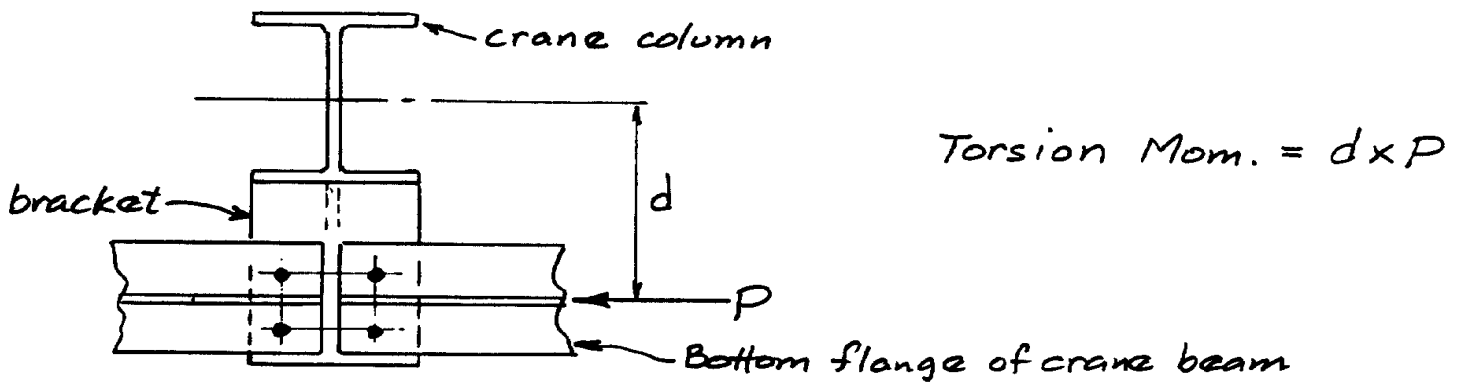

Figure 13

connections. In sketch C of Fig. 12, note that if the lateral load is directed *away* from the column, the vertical leg of the angle is subject to bending and the bolt is in tension at a time when it is trying to slide along the slot, certainly not an ideal situation. There should be a beveled washer on the inside of the channel flange and this washer must be welded to keep it from rotating and binding. All-in-all, sketch C might better be your last resort, if nothing else works.

Longitudinal forces cause torque on columns which have crane brackets. (See Fig. 13.) If this proves to be too great for the column, the effects of the torsion can be significantly reduced by adding horizontal struts. (See Fig. 14.)

The braces shown in Fig. 14 are not required at every column, but should be located near the center of the runway at as many columns as the loads and judgment dictate.

When it becomes uneconomical, inconvenient, or unwise to use a bracket to support the crane beam, then a "stepped" column should be considered. (Stepped columns can also be used for lighter cranes. Figure 15 shows a typical detail of a crane beam connecting to a stepped column.)

Notice that as the deflected beam delivers its load to the column the fulcrum is near the edge of the column flange, which is not desirable. This portion of the column flange and the beam web above it are subject to stress concentrations. In some instances it may prove beneficial to add reinforcing to the column. (See Fig. 16.) However, when this is required the load is delivered more eccentrically to the column, so in this situation it is probably wiser to consider the ultimate in crane beam support, which is a separate crane column. Crane beams for heavy service are best

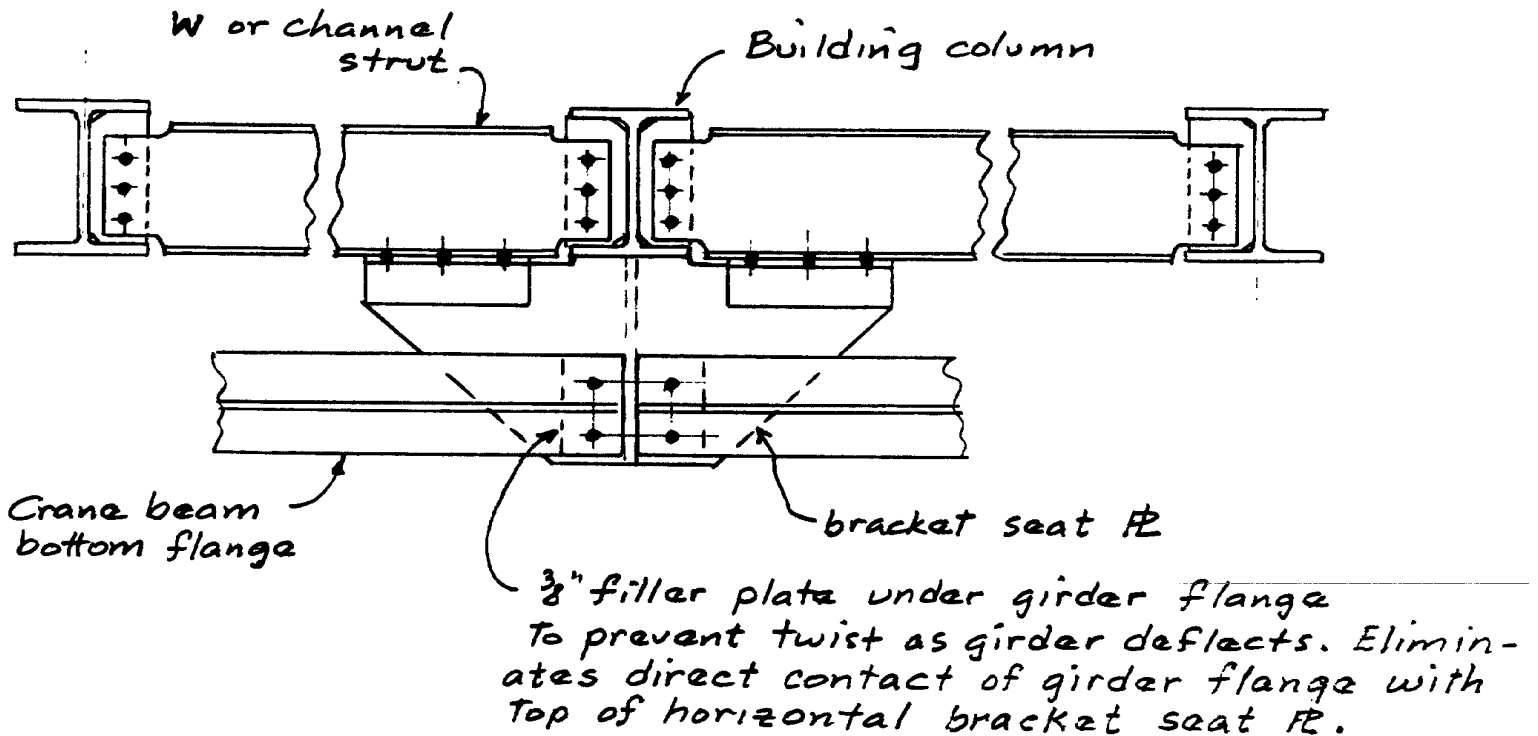

Figure 14

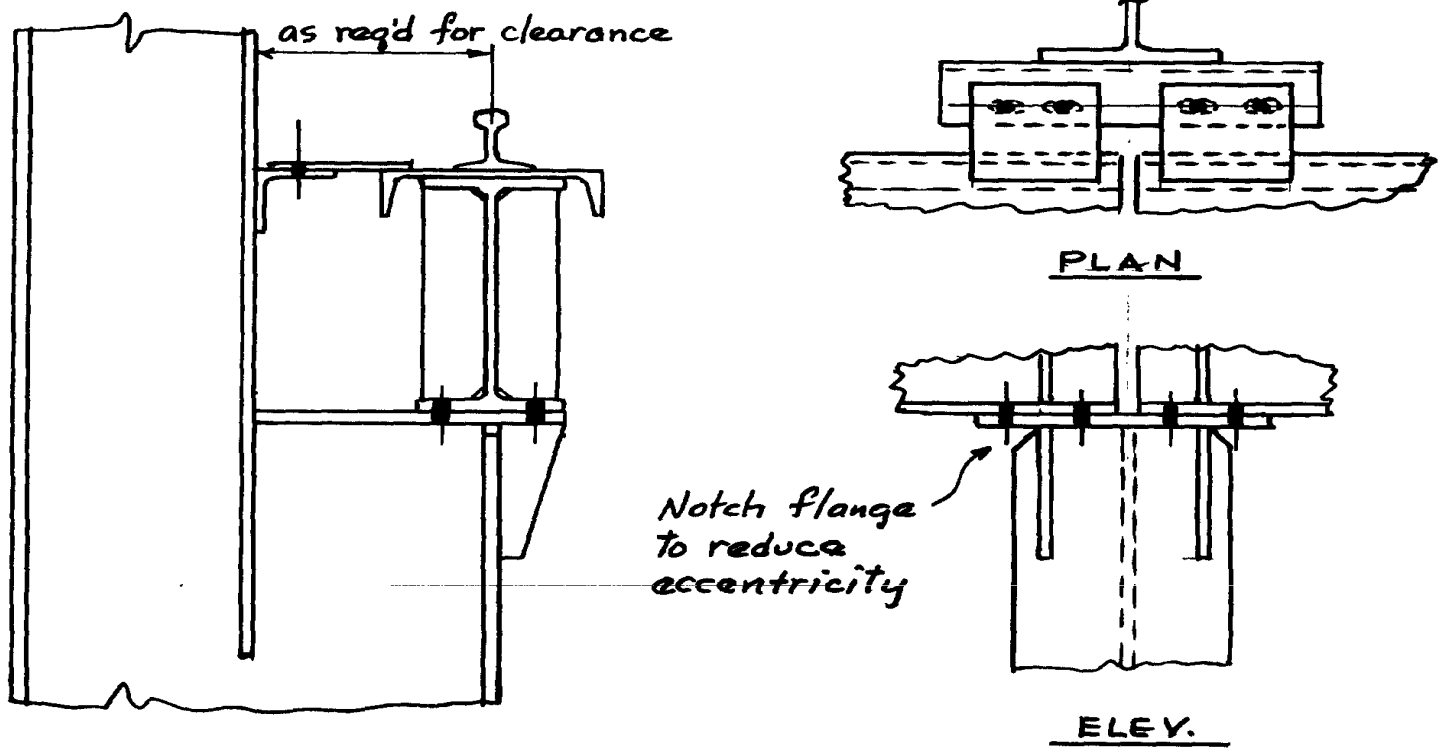

Figure 15

supported by their own columns. Refer to Fig. 2.

The usual and logical orientation of these columns is shown in Fig. 17.

The building column is oriented so that its strong axis will withstand the lateral wind and seismic loads on the building and the lateral crane loads. The crane column is oriented so its strong axis is able to resist the longitudinal forces on the runway. The crane column flanges also act as a fulcrum on which the crane beam will pivot as it deflects.

Keep the depth of a crane column as small as practical—do not use a W14 if a W12 will do, etc., in order to keep the load eccentricity as small as possible. (See Fig. 18.)

In Fig. 18, note the caution about not adding stiffener plates below the cap plate. This would increase the eccentricity of the load delivered by a deflecting beam. Even without the stiffeners, *this region of the column is subjected to severe cyclical loading conditions*. As the crane passes along the runway, the load is delivered first to one flange and then the other. Occasionally cracking is observed in the

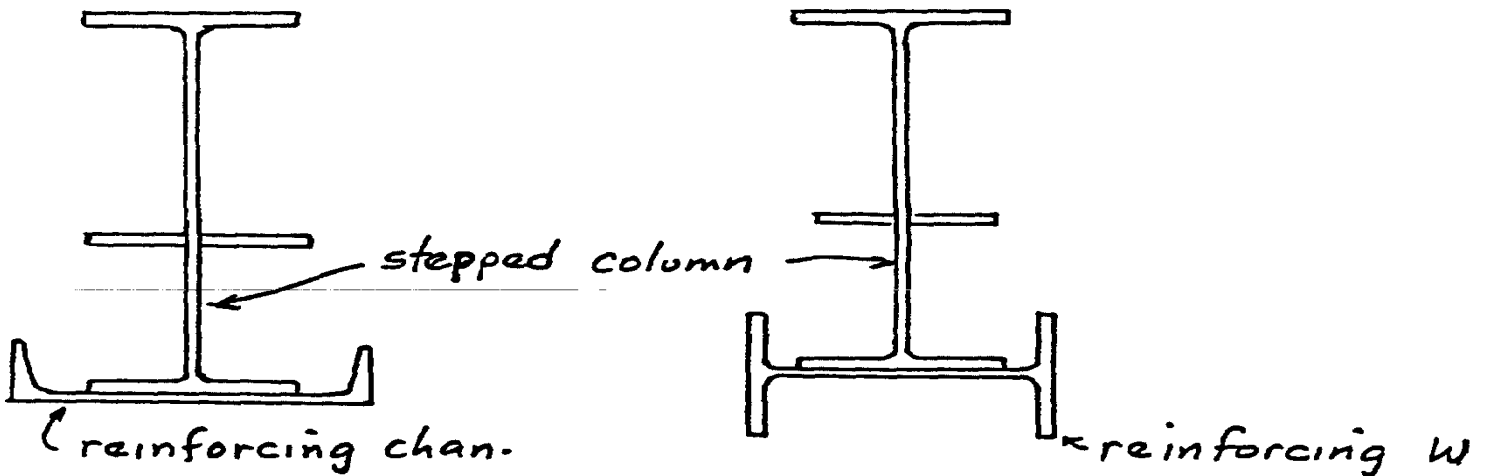

Figure 16

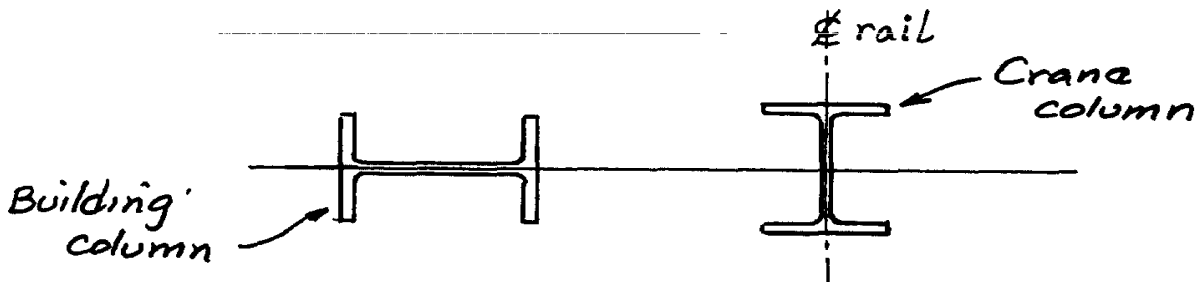

Figure 17

region below the cap plate. Note that the stiffeners in the crane beam are placed directly over the crane column flanges.

Note also that in none of the previous discussions have we mentioned anything about connecting the ends of two neighboring crane beams together. It should *not* be done. Likewise, the ends of two adjacent *horizontal* crane girder bracing members should not be tied (connected) together but should be attached separately to the column or bent by individual plates (see Fig. 19). Refer to Fig. 20 which shows exaggerated end rotation due to beam deflection. It is obvious that a plate connecting these members would find itself in a lot of trouble. Note also that a rail splice in the area above the beam gap would be under severe tension. It is advantageous to keep the gage in the bottom flange of the crane beam as large as practical, to permit the flange to yield

locally as the end rotates.

You may also have noted that none of the previous sketches have shown a diaphragm connecting the beam *web* to the column. This detail should be avoided; a web diaphragm localizes stresses in the beam web just below the top flange, which quite often leads to fatigue failure, cracks and loss of strength. (See Fig. 21.)

Now, after suggesting that you not use a "vertical diaphragm" for lateral bracing, it must be pointed out that it is permissible under certain conditions, but that precautions must be taken. On very heavy crane runs, where top flange lateral bracing cannot be made of adequate strength, a diaphragm can be added. Consider this a safety feature in case the horizontal thrust connection fails or is inadvertently weakened or destroyed by subsequent alterations. If diaphragms must be used, the crane girder end rotation should

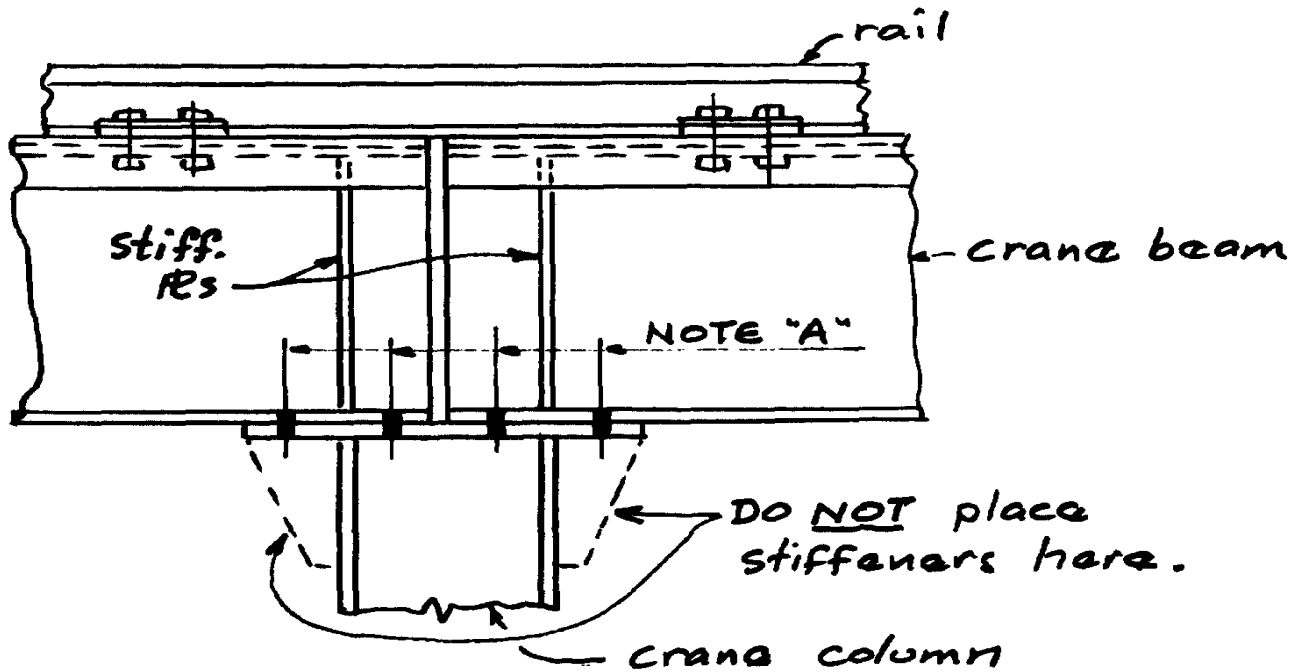

NOTE "A": these bolts must be capable of withstanding the longitudinal forces.

Figure 18

Longitudinal slots in WT. - Holes in Fls - bolt finger tight and nick threads

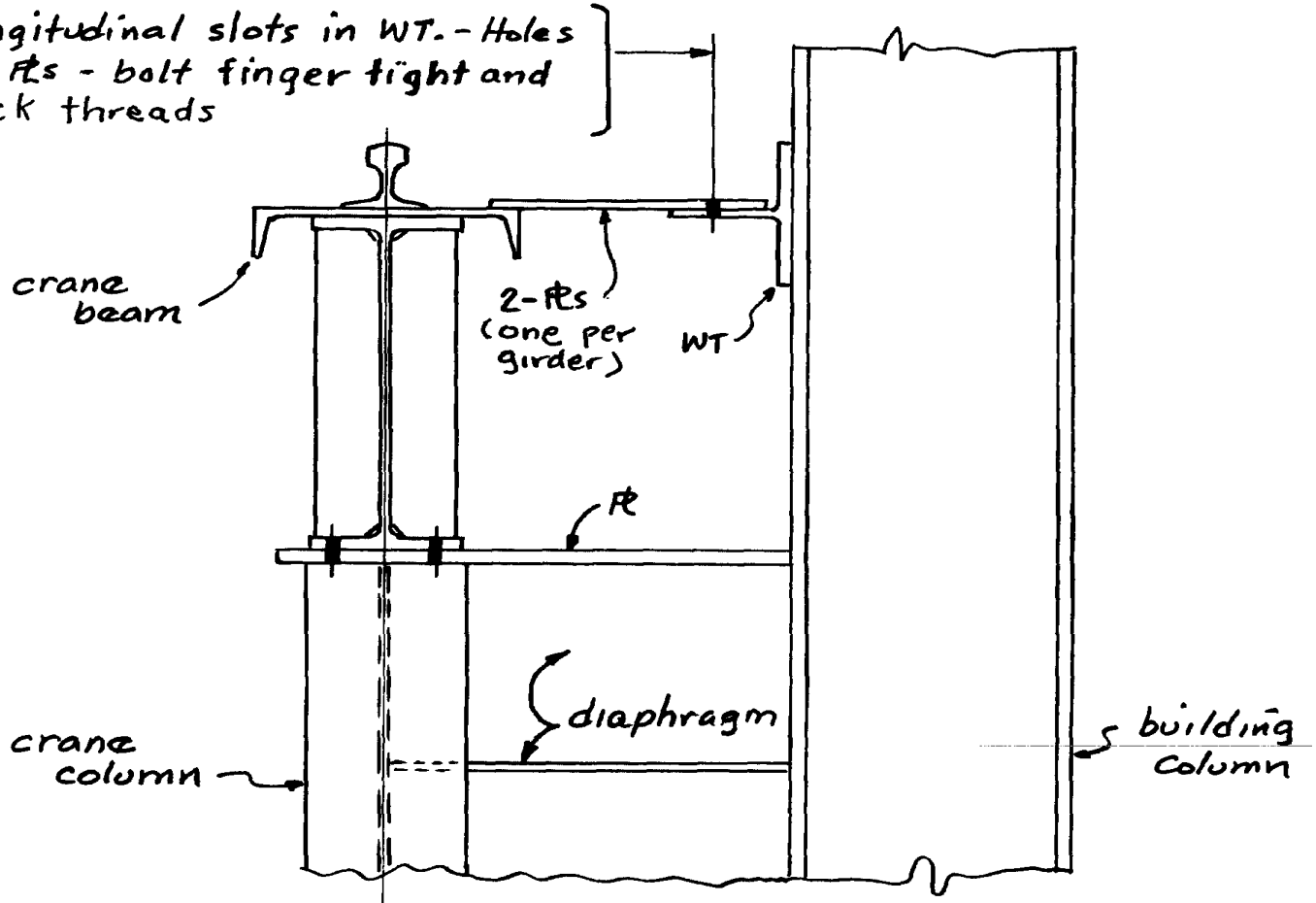
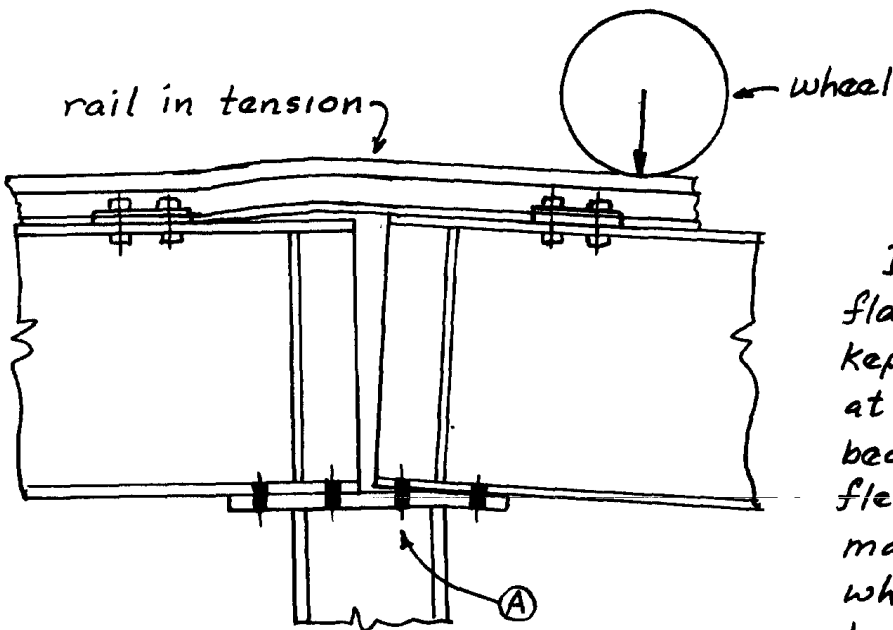

Figure 19



If the gage in the bottom flange of the crane beam is kept reasonably large the bolts at A will not stretch. The beam flange and cap Fl will flex slightly but probably maintain contact. Any gap which occurs will be directly below the beam web.

Figure 20

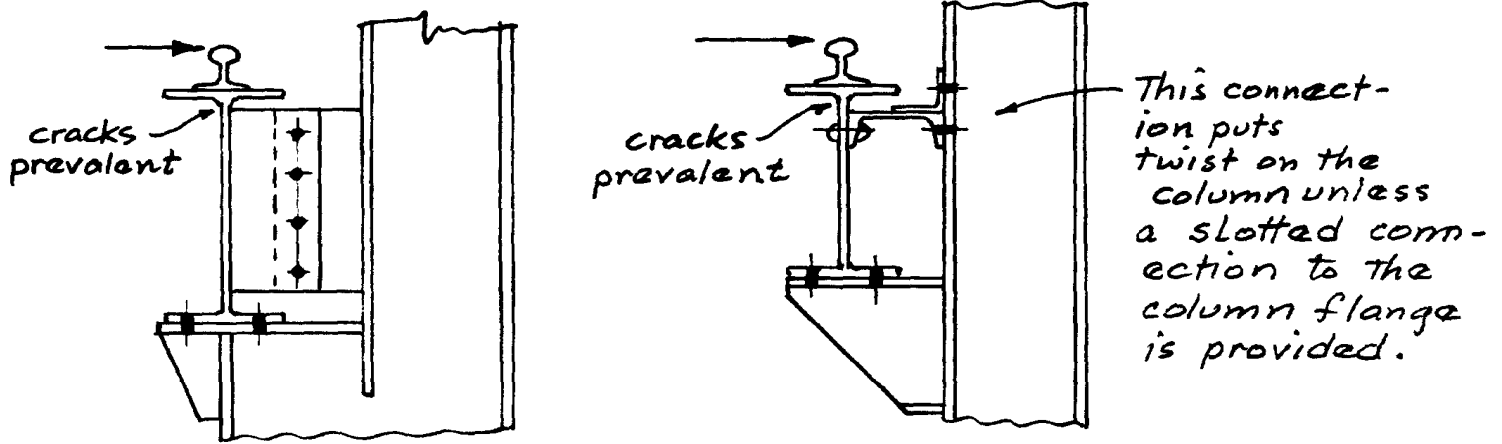

Figure 21

be kept very small. A single diaphragm should *not* serve two crane beams—a diaphragm should be supplied for each beam end. (See Fig. 22.)

It is probably a good idea to run these diaphragms full depth of the crane beam, and the plate thickness should be kept as thin as practical, say in the $\frac{5}{16}$ -in. to $\frac{3}{8}$ -in. range, to maintain flexibility.

Another case of where a diaphragm may be used is between two parallel crane beams or between a crane beam and a bracing girder, but this diaphragm should be horizontal and may be utilized as a walking surface or work platform if all due safety precautions and codes are observed. This diaphragm should be also kept flexible, to permit unequal deflections between the two members.

We have rambled on concerning crane beam deflection, end rotation, and associated headaches. Figure 23 is a design example that will give you an idea of the magnitude of this motion.

As this example shows, the magnitudes of these movements are relatively small. But the magnitude of the forces causing the motion are large. It is futile and uneconomical to attempt to restrain the motion, so we must use connections which permit the motion while maintaining their strength.

Whereas we have previously stated that expansion joints are not required or desirable in crane *rails*, such is not the case in the crane run. Expansion joints should be supplied at intervals coinciding with those in the main structure. The maximum distance between expansion joints should be about 400 ft (up to 500 ft in a building where the temperature range is not extreme.) Expansion joints for exterior crane runways should generally be closer, due to the probability of a greater temperature range. Where possible, use dual columns rather than a slide bearing.

If a slide bearing is used beneath the bottom flange of the crane girder, it must be made of a type of material which will permit rotation. "Floating" rail clamps should be used if a

crane runway contains expansion joints. Crane runways subject to concentrations of high heat, such as smelters, soaking pits, and furnaces, should be examined for abnormal expansion joint requirements. Heat shields are sometimes required to protect the exposed members.

Each segment of runway between expansion joints should be independently braced longitudinally.

Column bases must be designed to properly deliver the horizontal loads to the foundation, both lateral and longitudinal. Column bases sometimes are subject to uplift forces from the vertical component of diagonal bracing and from certain loading positions on two-span or cantilevered girders.

Column bases subject to rotation, such as the case where the crane column is attached to the building column in such a way as to form a vertical truss, should be designed so that the moment forces are delivered to the foundation.

FOUNDATIONS

The crane column foundations must be designed to adequately resist all of the vertical, horizontal, and rotational forces previously referred to. The magnitude of the forces is dependent upon the design of the superstructure and especially the bracing. Column bases should be kept above grade to minimize corrosion damage and so their condition may be easily monitored.

BRACING

Crane runways must be braced laterally and longitudinally. Lateral bracing is usually attained by providing either some degree of column base fixity, by utilizing the roof trusses or rafters, or by providing a vertical bent in conjunction with the main building column or an adjacent runway column.

Longitudinal runway bracing can take several different forms. Refer to Fig. 24, which shows several types. The simplest bracing to design and the most effective is the diagonal

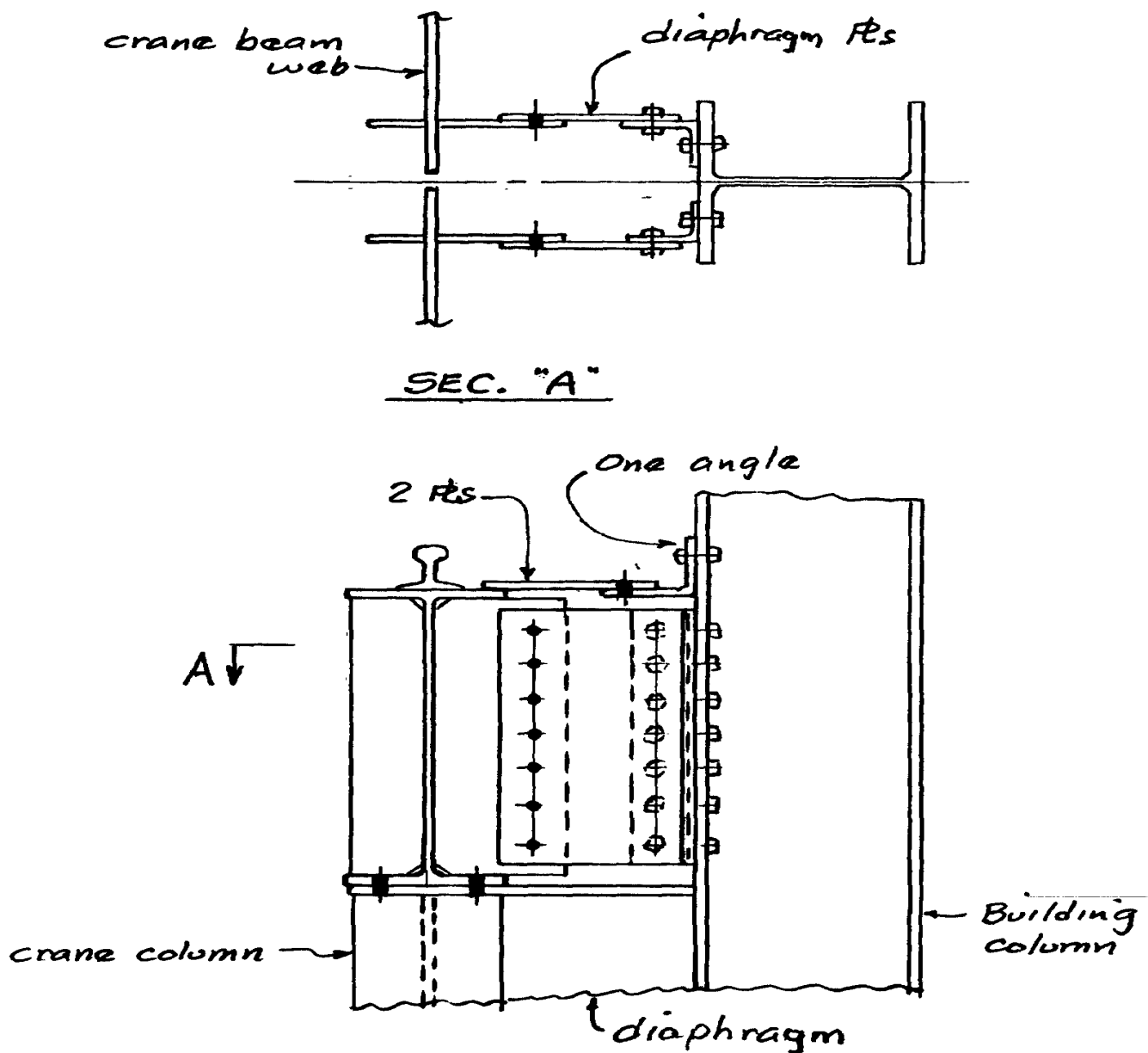
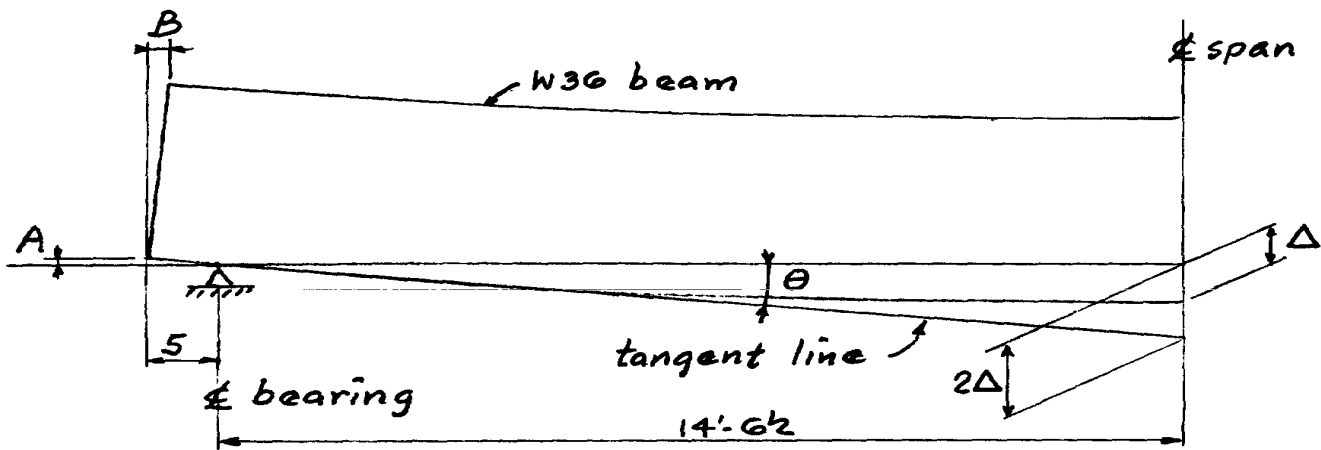

Figure 22

X-brace shown in Figure 21A. It is suggested that the engineer limit the L/r ratio of tension crane runway bracing to about 200, due to the abrupt reversal of stresses which are characteristic of crane runs. Bracing members should be constructed of efficient sections, such as double-angle members, wide-flange, tube, or pipe sections. Never use rods and limit single angle bracing to light service crane runs. "Slack" bracing members are a disconcerting sight in any structure. Never connect bracing directly to the underside of the crane beams.

If headroom is a problem either of the schemes in Fig. 24B or 24C can be used. The moment induced in the columns in Fig. 24C must be accounted for in the design of those columns. Foundations must be designed to handle the vertical and horizontal load components delivered by the bracing.

The bracing shown in Fig. 24 should be located on the center line of the crane columns. If stepped columns or columns with brackets are used, the bracing is generally located near the center line of the column and serves to



GIVEN: W36 beam 30'-0 c.c. crane columns. Max. $\Delta = L/1000$.

REQUIRED: Dimensions A & B.

PROCEDURE: $\text{max. } \Delta = \frac{29.08(12)}{1000} = 0.35"$ $\tan \theta = \frac{2(0.35)}{14.54(12)} = 0.004012$

DIM." A" = $0.004012(5) = 0.02"$. (less than $\frac{1}{32}"$)

DIM." B" = $0.004012(36) = 0.144"$. (less than $\frac{5}{32}"$)

Figure 23

brace the structure from wind and other external forces, as well as from the crane system.

Crane columns and crane bracing are often subjected to damage or abuse due to their proximity to moving loads. It is false economy to "skimp" on these members (or any crane runway members for that matter!)

The location of longitudinal bracing has always been a source of design conjecture. Consider the runway in Fig. 25.

Some designers start out by placing a braced bay on either side of, and adjacent to, the expansion joint, to try to "contain" the runway and keep it plumb. But this tends to defeat the purpose of the expansion joint by preventing or restraining movement in the adjacent bays. It is proper *not* to brace near the end of the runway, but rather to locate the bracing near the center of the runway. This will allow thermal expansion and contraction to advance or retreat from a centrally "anchored" area of the runway towards the ends.

In order to keep as many bays as possible clear for access to neighboring crane aisles, the crane bracing location often must coincide with that of the building bracing. However more crane bracing is often required than building bracing, and it may be necessary to provide crane run bracing in adjacent bays, but near the centrally anchored area. See Fig. 25. Experience has shown that, if a braced bay becomes objectionable to the mill operation, it may mysteriously

disappear. It is comforting to know that an occasional brace can be eliminated without jeopardizing the performance of the runway. The number of braced bays is usually up to the judgment of the engineer, but the following should be kept in mind. The length of each bay changes with temperature and, when under load, the bottom flange of the loaded girder will elongate. See Fig. 26 for an exaggerated portrayal of the cumulative effects of these movements.

For example, consider the following conditions with reference to Fig. 26:

Given: Bay length = 25'-0"

Bay 2-3 is loaded to cause a 3/16" elongation of the beam bottom flange.

Temp. = 100° F (30° above normal).

Required: Find the relative movement of the top of Column 1 in reference to Column 4 (an "anchored" column).

Solution: $\text{Temp. } \Delta = 30 \times (0.0000065)(75)(12) = 0.17"$ (about 3/16")

Total movement = $3/16" + 3/16" = 3/8"$

Comment: If a diagonal X-brace were contemplated for bay 1-2 and if its angle with the horizontal were about 45°, then the required stretch in this member would be about $0.707(0.375) = 0.27$

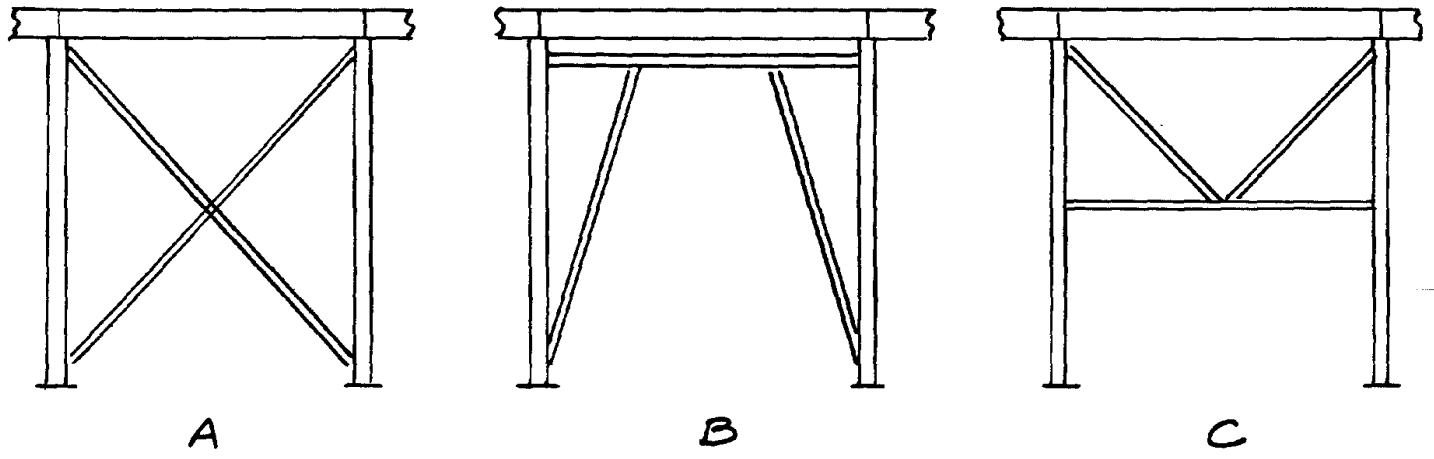

Figure 24

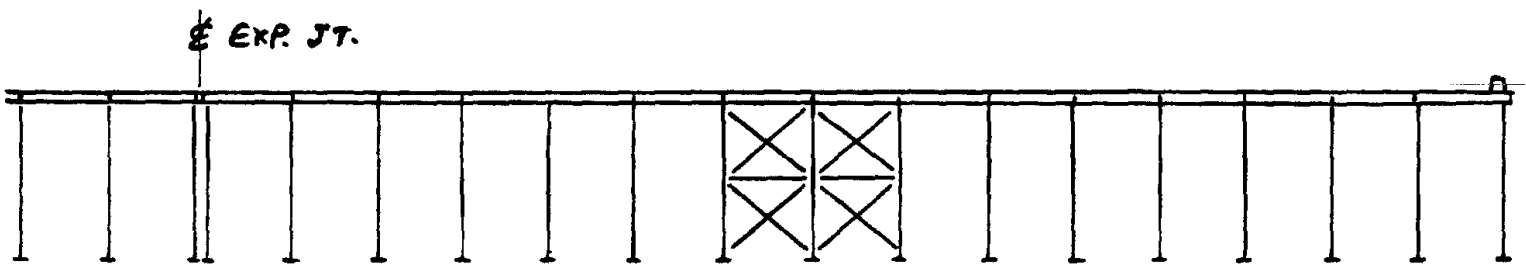

Figure 25

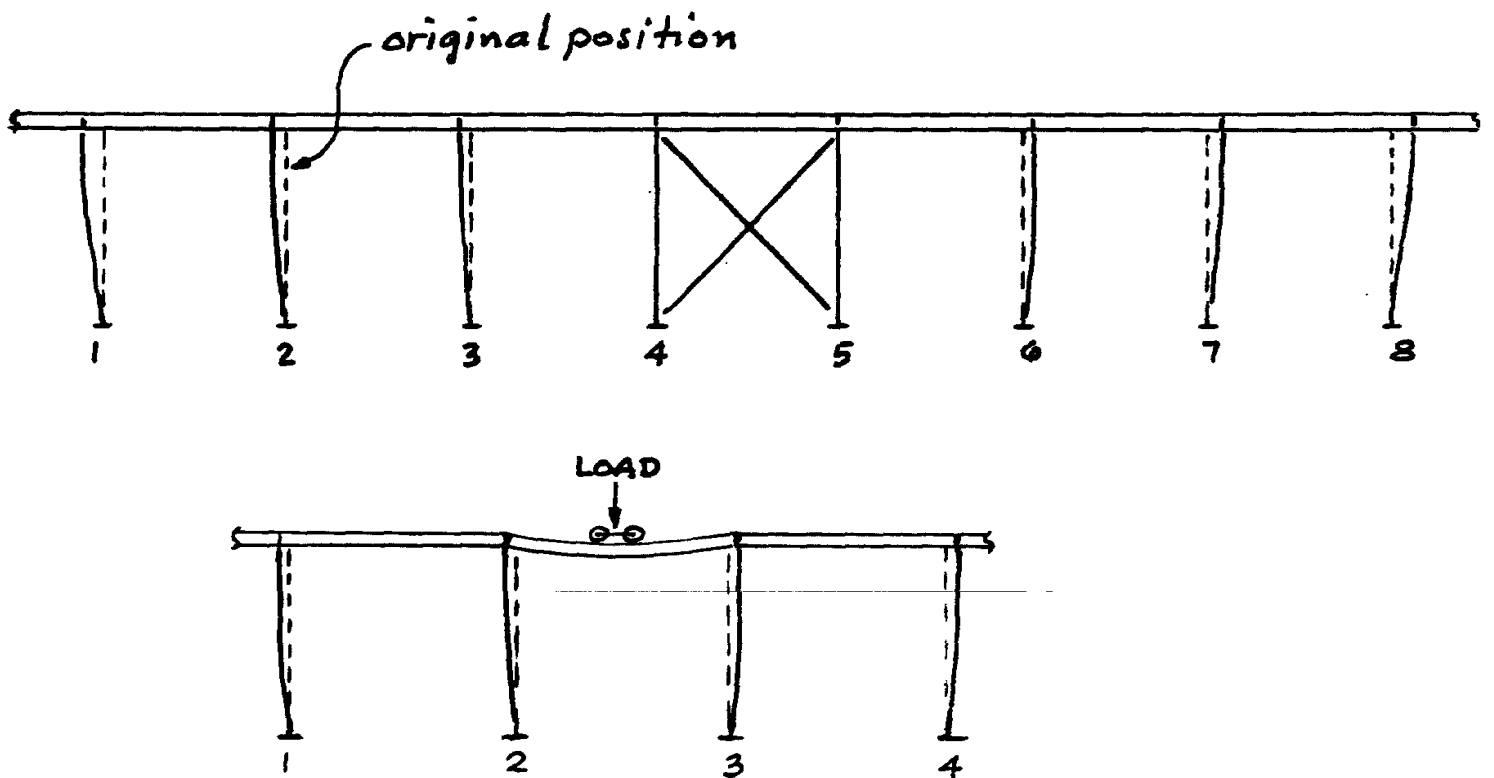

Figure 26

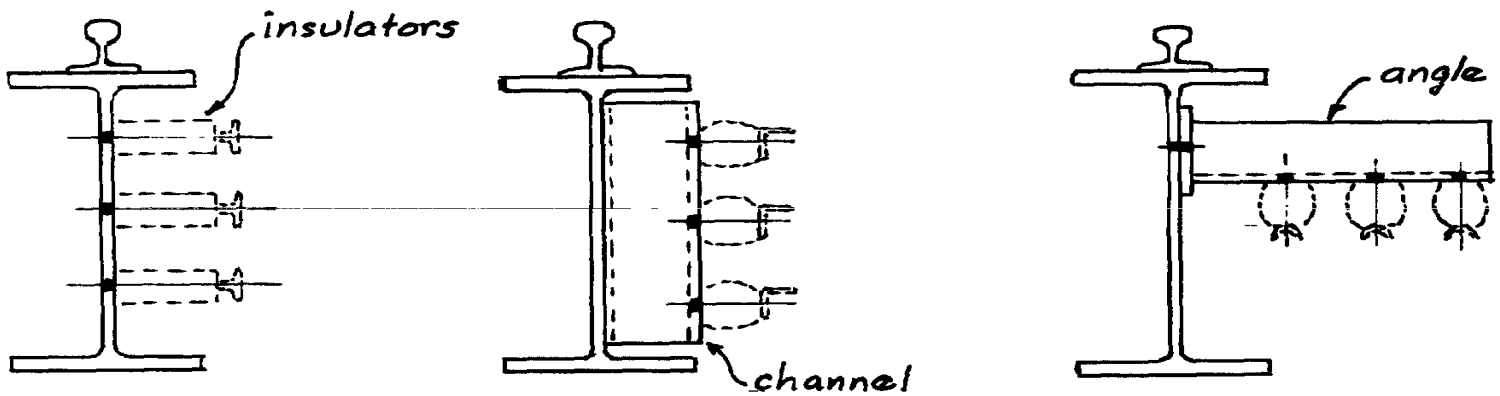

Figure 27

in. If the bracing member were 35 ft long and had an area of 4 in.², the force from this increment alone would be:

$$P = \frac{A E e}{L} = \frac{4(29 \times 10^3) 0.27}{35 \times 12} = 73 \text{ kips}$$

Obviously, if it were A36 steel the brace would be stressed near the working limit and might not be able to withstand the other longitudinal runway loads to which it would be subjected. And no self-respecting foundation would stand for this sort of nonsense. Actually, there is no point in attempting to return the top of Column 1 to its original position. If we did attempt to pull it back, other yielding would occur and it would not be necessary for this diagonal brace to realize the full 70-kip theoretical load.

It is interesting to observe bracing behavior while a crane is operating on a runway. The effects of impact, braking, traction and reversing directions can be witnessed when the crane is often several bays away.

Notice that we have *not* mentioned knee bracing (angle or diaphragm type) as a means of stabilizing a crane run. Knee braces should *not* be used. They are the source of many crane run problems, causing undesirable restraint, column bending, and secondary stresses. They may transmit unwanted forces into the foundation. An engineer who does investigations of existing crane runways should take a long hard look at any knee braces and assess their effect on other members of the runway. Replacement with X or portal bracing may be justified. There are case histories of satisfactory knee bracing, but there are usually mitigating circumstances which are responsible for their longevity, such as a favorable depth/span ratio (very small crane beam deflection) or a reduced crane capacity.

More on this topic can be garnered from a 1965 AISC *Engineering Journal* paper by John E. Muller.¹⁰

Parallel crane girders in adjacent crane aisles should not

be relied on to brace each other, except to be utilized to form a horizontal truss or girder, or box member. This member should be designed to withstand the maximum lateral loads of both cranes simultaneously.

CONDUCTORS

Crane runway conductors are the means by which the crane receives its electrical power. The rigid type is generally used, although occasionally a festoon type is found.

Usually the fabricator of the runway steel need supply only holes or a bracket with holes in it for mounting the conductor insulators. In some cases, the crane supplier will furnish the entire runway power system as part of a package deal. In cases where he doesn't, he will generally recommend the power system to be used in order to assure that it is compatible with his crane components.

Figure 27 shows several different typical schemes. The conductor supports are spaced usually about 4 to 15 ft apart, depending on the size and type of conductor rails.

CONCLUSION

The pros and cons of the several components and details of construction, as well as the various design approaches, can be argued indefinitely. The bottom line is that the crane runway performs satisfactorily over its desired term of service with least cost to the owner.

The "life" of a mill building is commonly figured to be about 50 years. A crane runway which "lives" half that long without major reconstruction should delight its owner.

What may work well for one set of conditions may not work at all for a different set. The vast range of crane capacities and classes of service make one set of rules virtually impossible to apply to all runways. This is where the experience, judgment, and discretion of the designing engineer is important.

This paper had dealt almost exclusively with crane runways, with only occasional reference to the other parts of the building. The author has discussed certain design

criteria, construction methods, has called attention to things that are sometimes overlooked, and has attempted to point out certain aspects that are considered good practice today. The actual methods of design have not been discussed, as these are amply covered in numerous texts on the subject.

Among the best design sources are the 1979 AISC publication *Light and Heavy Industrial Buildings*² and the AISE Technical Reports No. 6⁵ and No. 13.³ Anyone contemplating the design of a crane runway would do well to examine these texts.

Another excellent source of crane information is the *Whiting Crane Handbook, 4th Edition*.⁷

The following suggestions will help to assure better crane runways:

1. Limit the deflection of the crane beams.
2. Avoid the use of cantilever crane beams or two-span crane beams if possible.
3. Don't use knee braces for longitudinal runway bracing.
4. Connect the *top flange* of the crane beams to the column to resist lateral loads. Do *not* connect the webs.
5. Remember to use reduced allowable stresses where cyclical loading would result in structural fatigue. (AISC Specification Appendix B).
6. Crane runway field connections should be made with properly tensioned high-strength bolts (using friction values) except where sliding connections are required. High-strength bolts (finger-tight) are preferable for sliding connections because of their toughness and greater resistance to abrasion.
7. Anticipate the worst possible operating conditions because these are sure to happen sometime.
8. Keep in mind that dealing with crane runways can be likened to stamping on red ants with golf shoes—the best intentions and earnest efforts are often only about 50% effective. Be conservative!!!

DISCLAIMER

The information, including engineering data, tables, figures, designs, details and supporting data presented in this booklet should not be used without independent examination and verification of its suitability by a licensed structural engineer, licensed professional engineer, or a competent licensed architect. The author disclaims any and all express or implied warranties, without limitations, and, particularly that of fitness for any general or particular purpose in regard to information contained or referred to herein. Anyone making use of the information and contents of this paper assumes all liability arising from such use.

REFERENCES

1. Manual of Steel Construction, 8th Edition *American Institute of Steel Construction, Chicago, Ill., 1980.*
2. Fisher, J. M. and D. R. Buettner *Light and Heavy Industrial Buildings American Institute of Steel Construction, Chicago, Ill., 1979.*
3. Guide for the Design and Construction of Mill Buildings *Technical Report No. 13, Association of Iron and Steel Engineers, Pittsburgh, Pa., 1979.*
4. Specifications for Electric Overhead Traveling Cranes *No. 70, Crane Manufacturers Association of America, Pittsburgh, Pa., 1975.*
5. Specification for Electric Overhead Traveling Cranes for Steel Mill Service *Standard No. 6, Association of Iron and Steel Engineers, Pittsburgh, Pa., 1969.*
6. Merritt, F. S. *Structural Steel Designers' Handbook McGraw-Hill Book Co., New York, N.Y., 1972.*
7. Weaver, W. M. *Whiting Crane Handbook, 4th Edition Whiting Corporation, Harvey, Ill., 1979.*
8. Gaylord, E. H., Jr. and C. N. Gaylord *Structural Engineering Handbook, 2nd Edition McGraw-Hill Book Co., New York, N.Y., 1979.*
9. Arntzen, J. C. *Crane Girder Construction Proceedings of the AISC National Engineering Conference, 1954.*
10. Mueller, J. E. *Lessons from Crane Runways AISC Engineering Journal, Jan. 1965.*