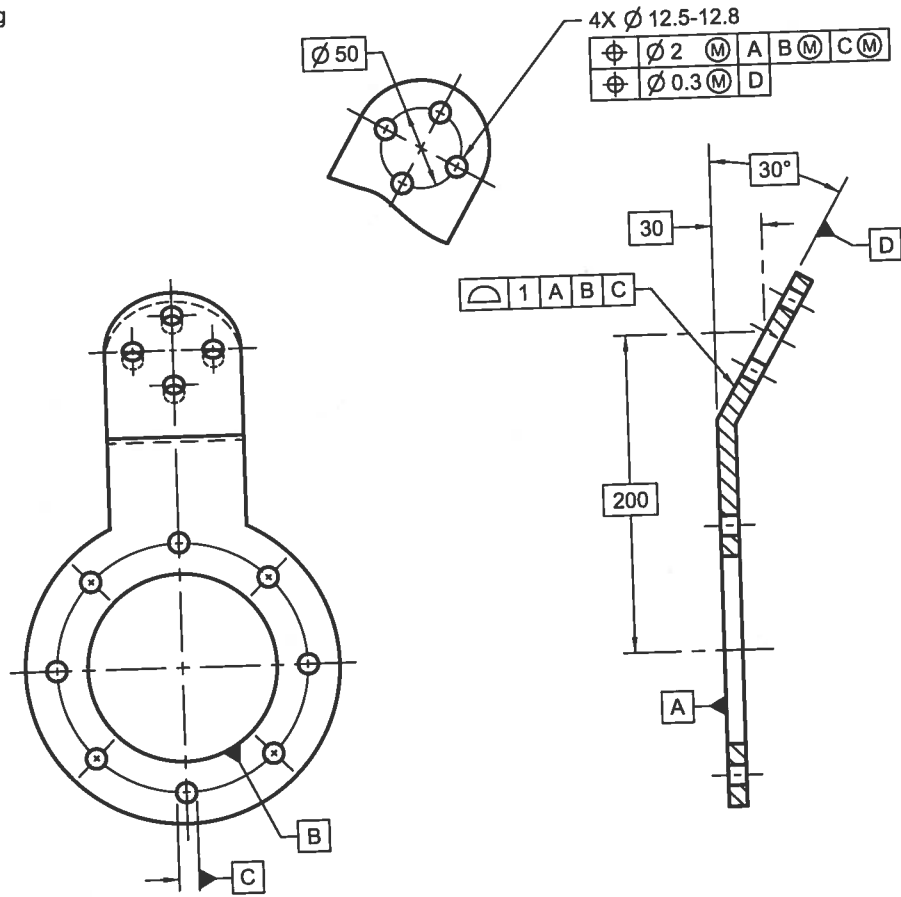

Fig. 7-55 Multiple Positional Tolerancing for a Pattern of Features

This on the drawing



8.5
7.5.5

Means this

