



USER'S MANUAL

Variable-frequency drives for 3-phase
and single-phase AC motors

175318	175318PCM
175319	175319PCM
175320	175321PCM
175321	175321PCM
175310	175310PCM
175322	175322PCM
175323	175323PCM
175311	175311PCM

LIMITED WARRANTY

A. Warranty - LEESON Electric warrants that its products will be free from defects in material and workmanship for a period of one (1) year from the date of shipment thereof. Within the warranty period, LEESON will repair or replace such products that are returned to LEESON or to the nearest Branch Office, with shipping charges prepaid. At our option, all return shipments are F.O.B. LEESON or its Branch Office. This warranty shall not apply to any product that has been subject to misuse, negligence, or accident; or misapplied; or repaired by unauthorized persons; or improperly installed. LEESON is not responsible for removal, installation, or any other incidental expenses incurred in shipping the product to or from the repair point.

B. Disclaimer - The provisions of Paragraph A are LEESON's sole obligation and exclude all other warranties of MERCHANTABILITY or use, express or implied. LEESON further disclaims any responsibility whatsoever to the customer or any other persons for injury to person or damage or loss of property of value caused by any product that has been subject to misuse, negligence, or accident, or misapplied or modified by unauthorized persons or improperly installed.

C. Limitations of Liability - In the event of any claim or breach of any of LEESON's obligations, whether expressed or implied, and particularly of any claim of a breach of warranty claimed in Paragraph A, or of any other warranties, express, or implied, or claim of liability that might, despite Paragraph B, be decided against us by any lawful authority, LEESON shall under no circumstances be liable for any consequential damages, losses, or expense arising in connection with the use of, or inability to use, LEESON's product for any purpose whatsoever. An adjustment made to the warranty does not void the warranty, nor does it imply an extension of the original one (1) year warranty period. Product serviced and/or parts replaced by a no-charge basis during the warranty period carry the unexpired portion of the original warranty only.

If for any reason any of the foregoing provisions shall be ineffective, LEESON's liability for damages arising out of its manufacture or sale of equipment, or use thereof, whether such liability is based on warranty, contract, negligence, strict liability in tort, or otherwise, shall not in any event exceed the full purchase of such equipment.

Any action against LEESON based upon any liability or obligation arising hereunder or under any law applicable to the sale of equipment or the use thereof must be commenced within one year after the cause of such action arises.

Safety Warnings



- This symbol  denotes an important safety tip or warning. **Please read these instructions carefully** before performing any of the procedures contained in this manual.
- **DO NOT INSTALL, REMOVE, OR REWIRE THIS EQUIPMENT WITH POWER APPLIED.** Have a qualified electrical technician install, adjust and service this equipment. Follow the National Electrical Code and all other applicable electrical and safety codes, including the provisions of the Occupational Safety and Health Act (OSHA), when installing equipment.
- Reduce the chance of an electrical fire, shock, or explosion by using proper grounding, over-current protection, thermal protection, and enclosure. Follow sound maintenance procedures.



It is possible for a drive to run at full speed as a result of a component failure. LEESON strongly recommends the installation of a master switch in the main power input to stop the drive in an emergency.

Circuit potentials are at 115 VAC or 230 VAC above earth ground. Avoid direct contact with the printed circuit board or with circuit elements to prevent the risk of serious injury or fatality. Use a non-metallic screwdriver for adjusting the calibration trimpots. Use approved personal protective equipment and insulated tools if working on this drive with power applied.

General Information

The LEESON FHP Series are solid-state, variable-frequency AC motor drives. The FHP utilizes a 115 or 230 VAC, 50/60 Hz, single-phase input, and is factory calibrated for an output of 0 to 60 Hz. They will operate any 1 HP or smaller, 115 or 208/230-volt, three-phase-AC-induction, single-phase permanent split capacitor motor (see page v) and can be user calibrated for 0 through 120 Hz output.

Although FHP inverters can operate over their full speed range, most motors will operate with constant torque over a 10:1 speed range, 6 Hz to 60 Hz, and constant horsepower above 60 Hz. (Inverter-duty motors may operate satisfactorily over a 20:1 speed range.) Some motors can be satisfactorily operated at speeds as low as 50 rpm (speed range 50:1). Below 50 rpm, some motors may show signs of “stepping” or “cogging”, and may run warmer.

*Although the FHP will allow a minimum of 0 Hz, the actual minimum frequency is dependent on motor type and load. The motor may need to be derated for low-frequency (30 Hz and lower) operation. Please consult the motor manufacturer.

Many 3-phase inverter manufacturers claim that they can run single-phase motors effectively. This is normally accomplished by wiring only 2 phases; however, this method may cause instabilities due to the lack of feedback from one of the motor connections. Furthermore, motor torque will be reduced considerably because the phases are 120° apart. Although the FHP uses this method of connection, its fundamental design enables it to operate efficiently under these conditions.

The FHP series features solid-state reversing with adjustable acceleration and deceleration. The FHP may also interface with motor thermal protection through the enable circuit.

FHP SERIES FEATURES & BENEFITS

- SOLID-STATE CIRCUITRY
- SOLID-STATE REVERSING
- ADJUSTABLE CARRIER FREQUENCY (4 kHz - 16 kHz)
- MULTIPLE MOTOR OPERATION
- THREE-PHASE AND SINGLE-PHASE MOTOR CONTROL

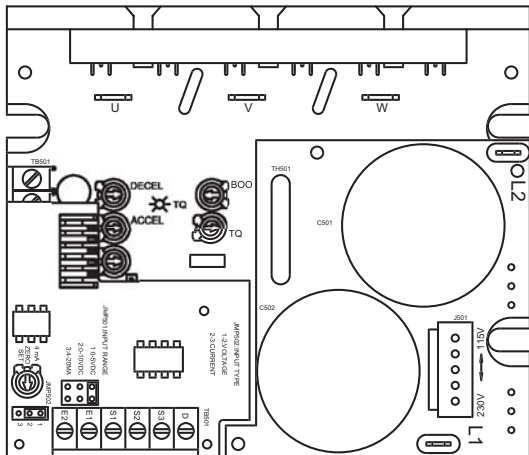

ACCEPTS A 0 - 5 VDC,
0 - 10 VDC, or 4 - 20 mA
NON-ISOLATED SIGNAL

DOUBLES THE OUTPUT
VOLTAGE TO THE AC MOTOR
WHEN 115 IS APPLIED

LED INDICATORS

POWER
(green)

FAULT
(red)

TORQUE
(yellow)

ADJUSTABLE CALIBRATION TRIMPOTS

DECEL

ACCEL

MAX

BOOST

TQ LIMIT

optional

ZERO SET

on isolation board

OPTIONAL ISOLATION BOARD

DOUBLER VERSIONS

Figure 1. FHP Series Features & Benefits

Important Information



Warning

Caution should be taken when operating fan-cooled motors at low speeds because their fans may not move sufficient air to properly cool the motor. LEESON recommends “inverter-duty” motors when the speed range is beyond 10:1.

In addition to standard 3-phase induction motors, the following motor types may be used with FHP Series drives:

- Permanent split capacitor (PSC)
- Shaded pole
- AC synchronous



The following motor types **MAY NOT** be used:

- Split phase
- Capacitor start
- Repulsion induction
- Series Universal AC/DC
- Any motor with starting switch (centrifugal or relay) and/or separate starting winding.

Contents

Safety Warnings	i
General Information	ii
Important Information	v
Specifications	1
Dimensions	2
Installation	10
175324 Process Control Module (PCM) Mounting	10
Mounting	15
Wiring	17
Shielding guidelines	18
Heat sinking	19
Fusing	20
Speed adjust potentiometer	21
Connections	22
Power and fuse connections	22
Motor connections (all FHP-series controls)	27
Speed Adjust Potentiometer Connections	31
Voltage Follower Connections	32
Signal and Optional Switch Connections	33
Voltage or Current Follower (PCM models)	35
Operation	37
Voltage Doubler	38
Startup	39
To reverse motor direction:	40
Starting and stopping methods	41
To coast the motor to a stop	41
Thermal protection of the motor	41
Line starting and line stopping	43

Calibration	44
Calibration Procedure Setup for 60 Hz Motors:	46
MAXIMUM SPEED (MAX SPD)	46
TORQUE LIMIT (TQ LIMIT)	47
ACCELERATION (ACCEL)	48
DECELERATION (DECEL)	48
BOOST	49
Calibration Procedure Conclusion	50
Application Notes	51
Independent adjustable speeds with DIR switch	51
RUN/JOG switch	52
Single speed potentiometer control of multiple motors	53
Quick Reversing	54
Troubleshooting	55
Before troubleshooting	55
Diagnostic LEDs	57
POWER LED	57
FAULT LED	57
TQ LIMIT LED	58
Optional C510 Capacitor Kit (p/n: 175325)	63
Replacement Parts	65

Tables

Table 1. Line Fusing Chart	20
Table 2. Replacement Parts	65

Illustrations

Figure 1. FHP Series Features & Benefits	iv
Figure 2. 175318, 175320, & 175321 Dimensions	2
Figure 3. 175322 and 175323 Dimensions	3
Figure 4. 175318PCM, 175320PCM and 175321PCM Dimensions	4
Figure 5. 175322PCM and 175323PCM Dimensions	5
Figure 6. 175319 & 175310 Dimensions	6
Figure 7. 175311 Dimensions	7
Figure 8. 175319PCM and 175310PCM Dimensions	8
Figure 9. 175311PCM Dimensions	9
Figure 10. FHP Series Drive with PCM adder board & PCM adder kit	11
Figure 11. Speed Adjust Potentiometer	21
Figure 12. AC Line and Fuse Connections for Single Voltage FHP Series Drives	23
Figure 13. AC Line and Fuse Connections for Doubler FHP Series Drives (Voltage Doubler Mode)	25
Figure 14. AC Line and Fuse Connections for Doubler FHP Series Drives (Not in Voltage Doubler Mode)	26
Figure 15. Motor Connections for Single-Phase Operation (Motor With Pre-Wired Capacitor)	28
Figure 16. Motor Connections for Single-Phase Operation (Configured for use with DIRECTION switch)	29
Figure 17. Motor Connections for Three-Phase Motors	30
Figure 18. Speed Adjust Potentiometer Connections to TB501	31
Figure 19. Voltage Follower connections	32
Figure 20. Enable / Disable Switch connections to TB501	33
Figure 21. Signal and Optional Switch Connections	34
Figure 22. PCM jumper locations and terminal connections	36
Figure 23. Thermal Overload Switch with Optional Enable / Disable Switch	42
Figure 24. FHP Series Calibration Trimpot Layout	45
Figure 25. Independent Adjustable Speeds	51
Figure 26. RUN/JOG Switch	52
Figure 27. Single Speed Potentiometer Control of Multiple Motors	53
Figure 28. FHP Quick Reversing	54
Figure 29. FHP Series diagnostic LED locations	58
Figure 30. Carrier frequency capacitor location	64

Specifications

Drive	1-Phase Input (VAC)	1 or 3-Phase Output (VAC)	Max HP	Max Continuous Output Current (AC)	AC Amps In
175318	230	230	¼	1.2	3
175319	*115 / 230	230	¼	1.2	7 / 3
175320	115	115	¼	2.4	7
175321	230	230	½	2.4	7
175310	*115 / 230	230	½	2.4	10 / 7
175322	115	115	½	4.0 [†]	10
175323	230	230	1	4.0 [†]	10
175311	*115 / 230	230	1	4.0 [†]	15 / 10

* Connect only 115 VAC line input to the 115 VAC terminals. Application of 230 VAC line input when set for 115 VAC will result in severe damage to the motor and drive, and possible explosion and injury.

† Derate current by 2% per degree if the operating temperature is above 40°C. Under no circumstances may the ambient temperature exceed 55° C.

AC Voltage Input Range

175320 & 175322	115 VAC ± 10%, 50/60 Hz single phase
175318, 175321, & 175323	230 VAC ± 10%, 50/60 Hz single phase
175319, 175310, & 175311	115/230 VAC ± 10%, 50/60 Hz single phase

Standard Carrier Frequency	16 KHz
Output Frequency Range	0 – 120 Hz
Adjustable Maximum Output Frequency Range	30 – 120 Hz
Acceleration Time Range	1 – 12 seconds
Deceleration Time Range	1 – 12 seconds
Analog Input Voltage Range (signal must be isolated; S1 [-] to S2 [+])	0 – 5VDC**
Input Impedance, S1 to S2	~ 100K ohms
Vibration	0.5G max (20 – 50 Hz) 0.1G max (> 50 Hz)
Weight	1.2 lb
Ambient Operating Temperature Range	10° – 40° C

** An isolation board option that allows for a non-isolated 0 - 5 VDC, 0 - 10 VDC, or 4 - 20 mA input signal is available (-PCM option). The option board is installed directly above the main board, maintaining the same footprint and dimensions. Call the factory for more information regarding the -PCM option.

Dimensions

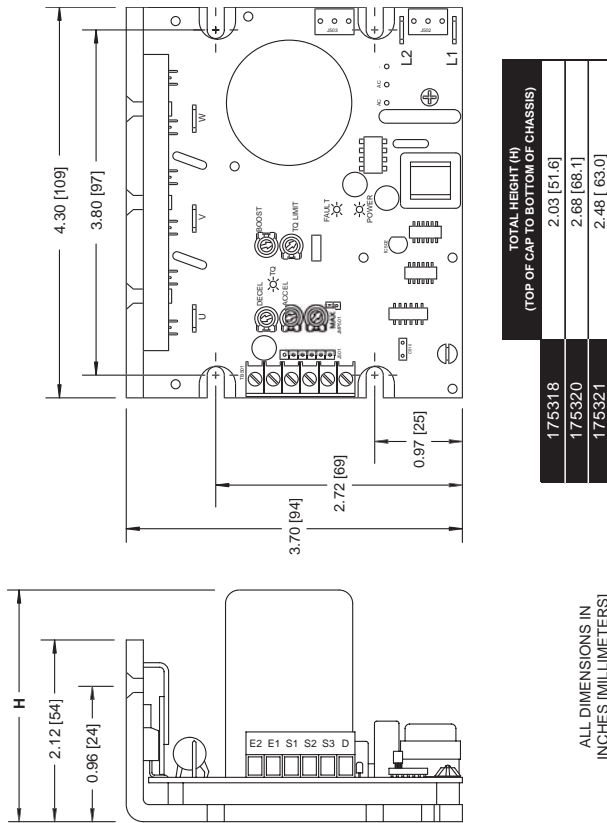

Figure 2. 175318, 175320, & 175321 Dimensions

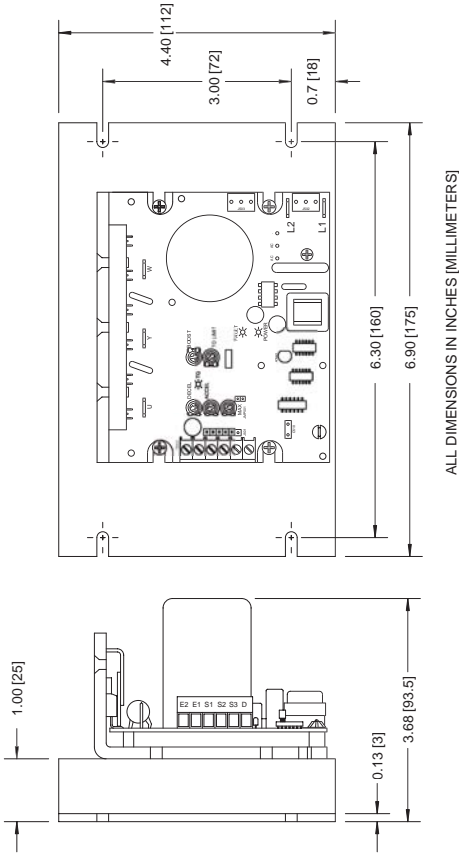
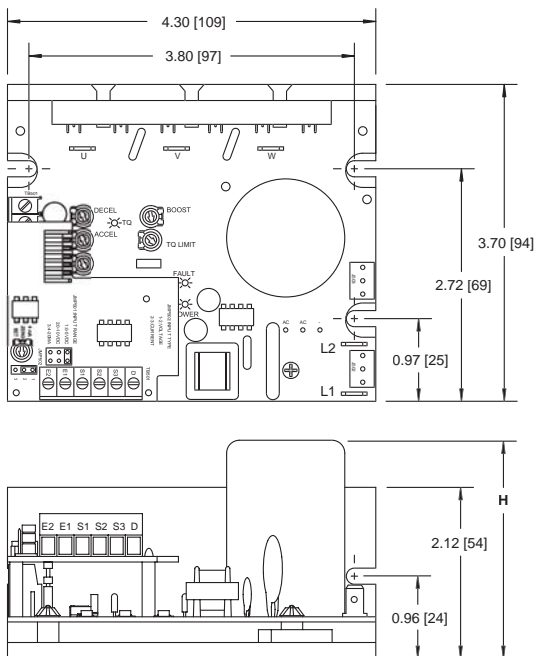

Figure 3. 175322 and 175323 Dimensions



	TOTAL HEIGHT (H) (TOP OF CAP TO BOTTOM OF CHASSIS)
175318PCM	2.03 [51.6]
175320PCM	2.68 [68.1]
175321PCM	2.48 [63.0]

ALL DIMENSIONS IN
INCHES [MILLIMETERS]

**Figure 4. 175318PCM, 175320PCM
and 175321PCM Dimensions**

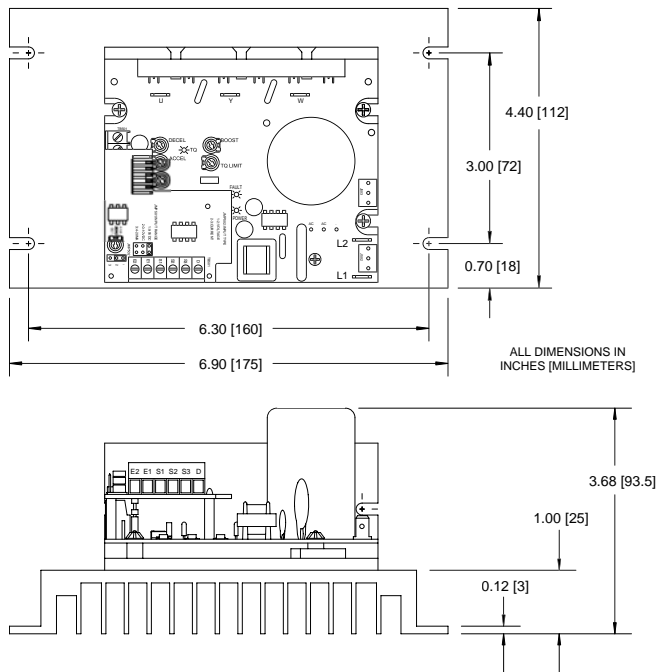
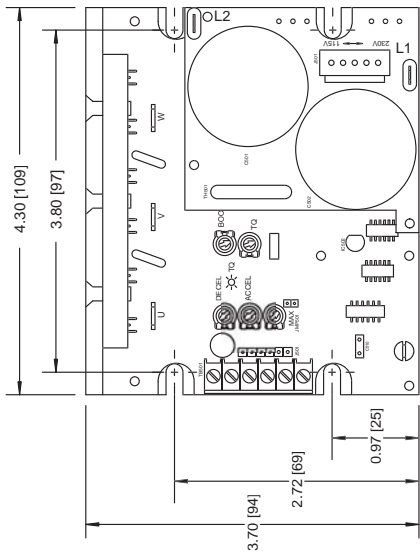
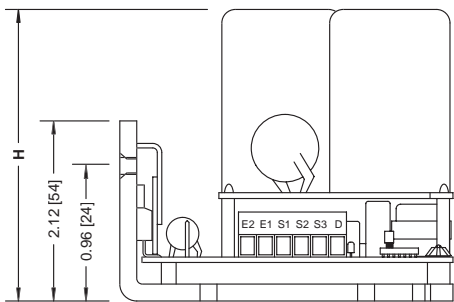

Figure 5. 175322PCM and 175323PCM Dimensions



TOTAL HEIGHT (TOP OF CAP TO BOTTOM OF CHASSIS)	
175319	2.56 [65.0]
175310	3.02 [76.7]

ALL DIMENSIONS IN
INCHES [MILLIMETERS]

Figure 6. 175319 & 175310 Dimensions

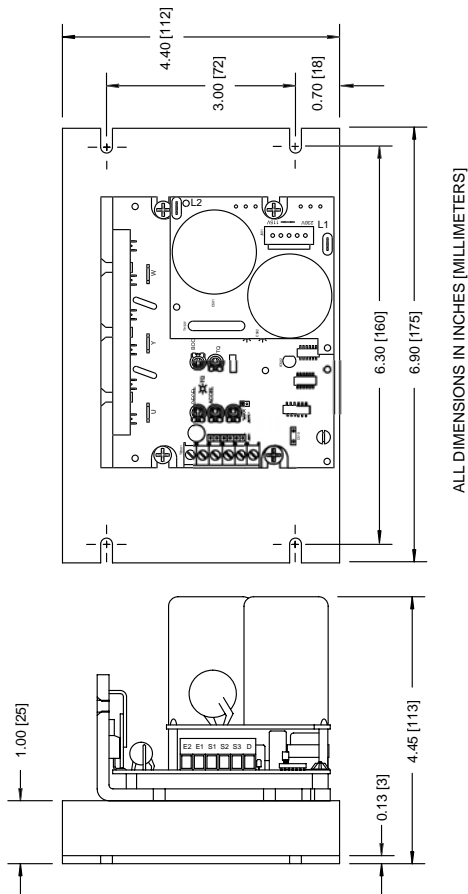
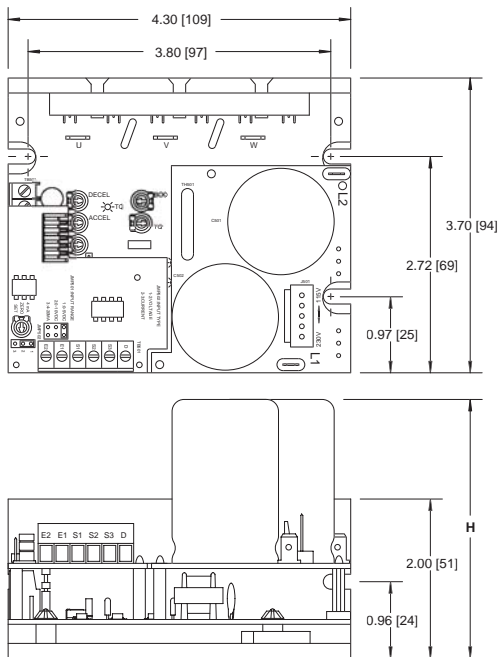

Figure 7. 175311 Dimensions



	TOTAL HEIGHT (TOP OF CAP TO BOTTOM OF CHASSIS)
175319PCM	2.56 [65.0]
175310PCM	3.02 [76.7]

ALL DIMENSIONS IN INCHES [MILLIMETERS]

Figure 8. 175319PCM and 175310PCM Dimensions

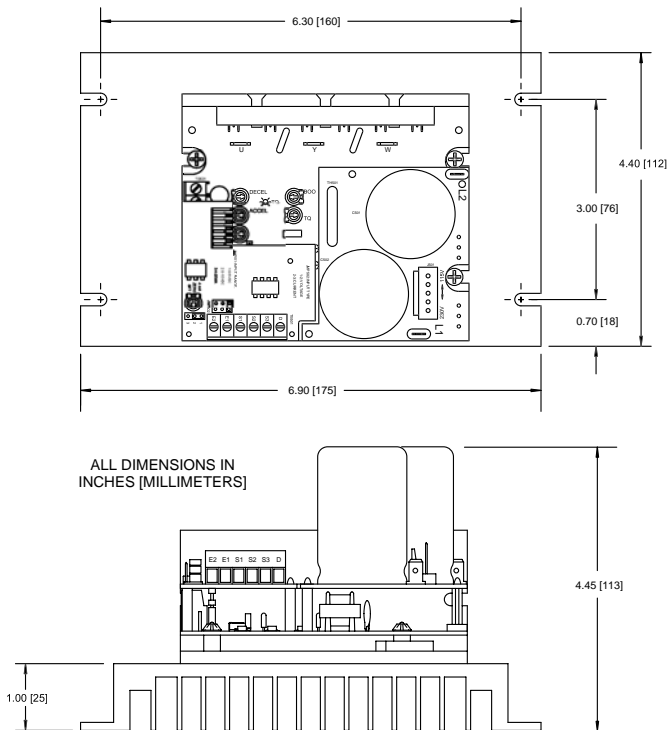
**Figure 9. 175311PCM Dimensions**

Installation

175324 Process Control Module (PCM) Mounting

The FHP Series PCM Adder Board accepts a 0 - 5 VDC, 0 - 10 VDC, or 4-20 mA signal and outputs an isolated 0-5 VDC signal without requiring additional panel space. It mounts directly over the main AC board (bottom board) thus maintaining the same footprint. Step-by-step information for mounting the PCM Adder Board to a FHP Series drive is shown on pages 12 - 14.

Figure 10 (page 11) shows a FHP Series drive with the PCM adder board installed on the unit and the parts supplied in the PCM adder kit.

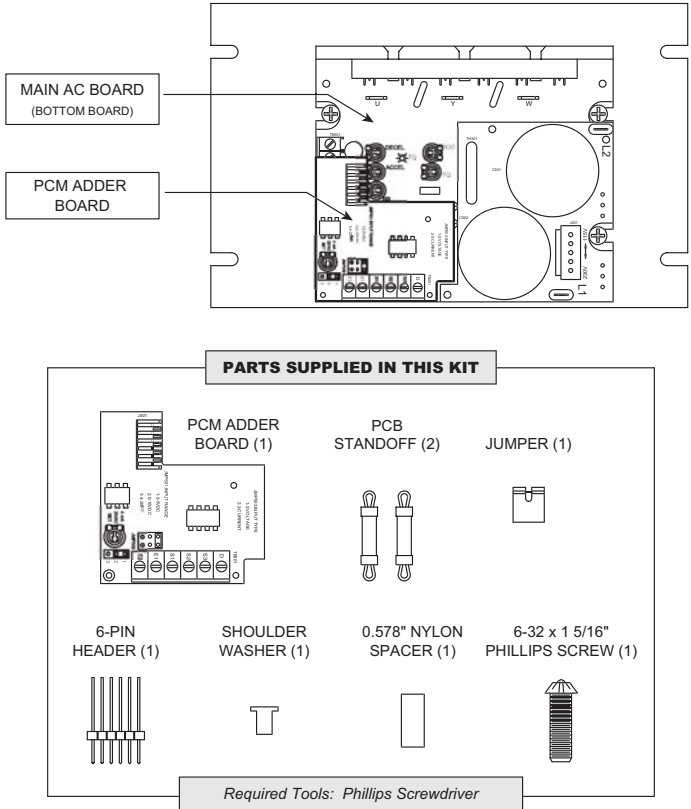
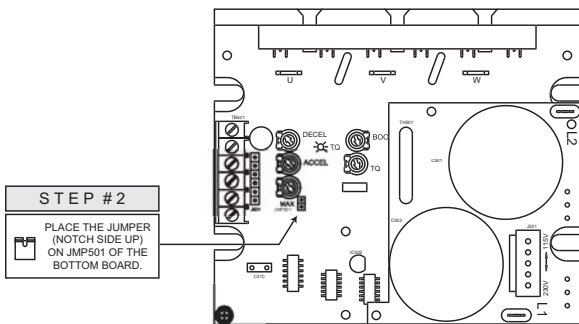
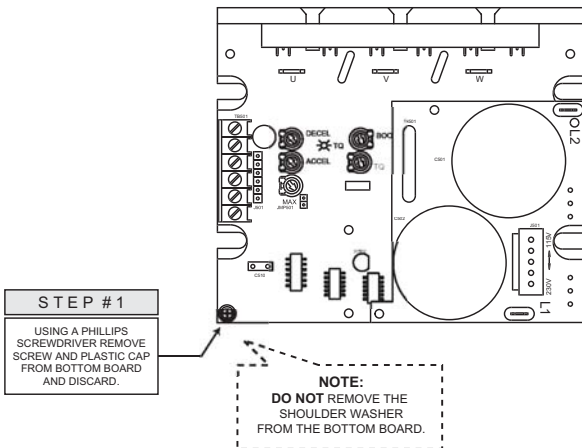
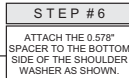
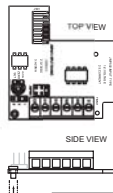
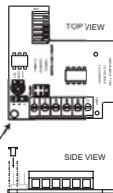
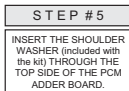
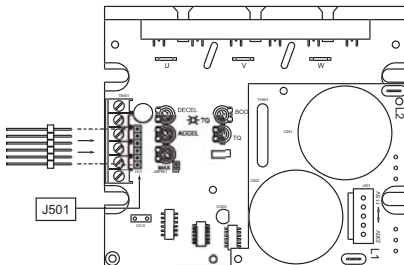
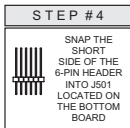
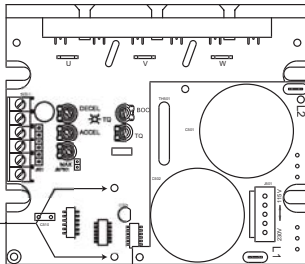
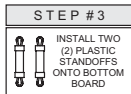
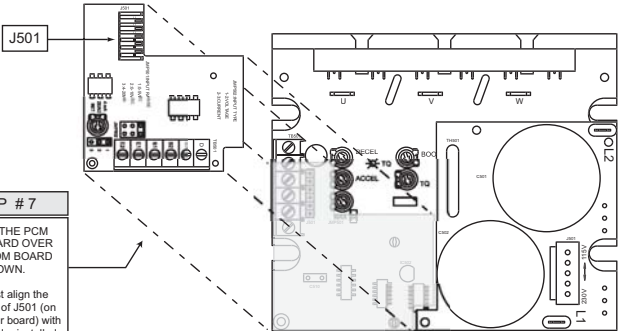

Figure 10. FHP Series Drive with PCM adder board & PCM adder kit





**STEP #7**

POSITION THE PCM ADDER BOARD OVER THE BOTTOM BOARD AS SHOWN.

NOTE: First align the bottom holes of J501 (on the PCM adder board) with the 6 pin header installed on the bottom board. The PCM adder board will snap into place at J501 and the two standoffs.

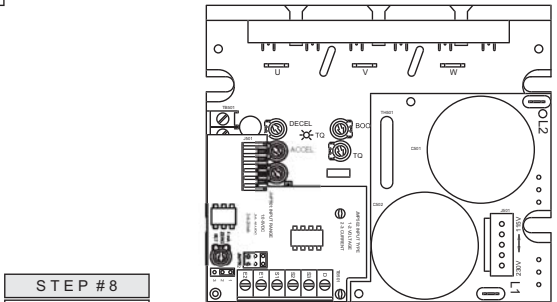
**STEP #8**

SECURE THE PCM ADDER BOARD WITH THE 6-32 x 1.5/16" PHILLIPS SCREW.

INSTALLATION COMPLETE.

Mounting



Warning

DO NOT install, rewire, or remove this control with input power applied. Doing so may cause fire or serious injury. Make sure that you read and understand the Safety Warnings before attempting installation.

NOTE: Horizontal mounting may require derating the drive. See your LEESON representative for more information

- It is recommended that the drive be oriented with the chassis vertical for best heat dissipation. Horizontal mounting, while acceptable, may require some thermal derating.
- Six 0.19-inch (5 mm) wide slots accept #8 pan head screws. Fasten either the large base or narrow flange of the chassis to the subplate.
- Drive components are sensitive to electrostatic fields. Avoid direct contact with the circuit board. Hold the drive by the chassis only.

- Protect the drive from dirt, moisture, and accidental contact. Provide sufficient room for access to the terminal block and calibration trim pots.
- Mount the drive away from heat sources. Operate the drive within the specified ambient operating temperature range.
- Prevent loose connections by avoiding excessive vibration of the drive.
- The chassis must be earth grounded. Use a star washer beneath the head of at least one of the mounting screws to penetrate the anodized chassis surface and to reach bare metal.

Wiring



Warning



DO NOT install, rewire, or remove this control with input power applied. Failure to heed this warning may result in fire, explosion, or serious injury.

Circuit potentials are at 115 or 230 VAC above ground. To prevent the risk of injury or fatality, avoid direct contact with the printed circuit board or with circuit elements.

Do not disconnect any of the motor leads from the drive unless power is removed. Opening any one motor lead may destroy the drive.

- Use 20 – 24 AWG wire for speed adjust potentiometer wiring. Use 14 – 16 AWG wire for AC line (L1, L2) and motor (U,V and W) wiring.

Shielding guidelines



Warning

Under no circumstances should power and logic leads be bundled together. Induced voltage can cause unpredictable behavior in any electronic device, including motor controls.

As a general rule, LEESON recommends shielding of all conductors.

If it is not practical to shield power conductors, LEESON recommends shielding all logic-level leads. If shielding the logic leads is not practical, the user should twist all logic leads with themselves to minimize induced noise.

It may be necessary to earth ground the shielded cable. If noise is produced by devices other than the drive, ground the shield at the drive end. If noise is generated by a device on the drive, ground the shield at the end away from the drive. Do not ground both ends of the shield.

If the drive continues to pick up noise after grounding the shield, it may be necessary to add AC line filtering devices, or to mount the drive in a less noisy environment.

Logic wires from other input devices, such as motion controllers and PLL velocity controllers, must be separated from power lines in the same manner as the logic I/O on this drive.

Heat sinking

LEESON 1-HP FHP drives (175322, 175323, & 175311) drives are delivered with a factory-installed heat sink. All other FHP-series drives have sufficient heat sinking in their basic configurations. No additional heat sinking is necessary.

Fusing

FHP series drives require external AC power line fuses. Connect the external line fuse(s) in series with the AC voltage input. See Connections on page 22. Use fast-acting fuses rated for 250 VAC or higher. See Table 1 for recommended line fuse sizes.

Table 1. Line Fusing Chart

Drive	1-Phase Input (VAC)	Max HP	AC Amps In	AC Line Fuse Size (Amps)
175318	230	¼	3	5
175319	115 / 230	¼	7 / 3	10 / 5
175320	115	¼	7	10
175321	230	½	7	10
175310	115 / 230	½	10 / 7	15 / 10
175322	115	½	10	15
175323	230	1	10	15
175311	115 / 230	1	15 / 10	20 / 15

Speed adjust potentiometer



Warning

Be sure that the potentiometer tabs do not make contact with the potentiometer enclosure. Grounding the input will cause damage to the drive.

Mount the speed adjust potentiometer through a 0.38 in. (10 mm) hole with the hardware provided (Figure 11). Install the circular insulating disk between the panel and the 10K ohm speed adjust potentiometer. Twist the speed adjust potentiometer wire to avoid picking up unwanted electrical noise. If speed adjust potentiometer wires are longer than 18 in. (457 mm), use shielded cable. Keep speed adjust potentiometer wires separate from power leads (L1, L2, U, V, W).

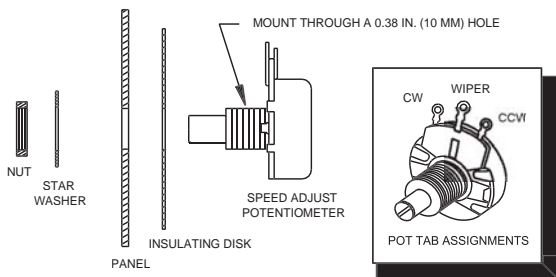

Figure 11. Speed Adjust Potentiometer

Connections



Warning

DO NOT connect this equipment with power applied. Failure to heed this directive may result in fire or serious injury.

LEESON strongly recommends the installation of a master power switch in the voltage input line. The switch contacts should be rated at a minimum of 200% of motor nameplate current and 250 volts.

Power and fuse connections

Single Voltage FHP Series Drives (175318, 175320, 175321, 175322, 175323)

Connect the AC power input to L1 and L2 as shown in Figure 12 (page 23). Connect an external fuse between the drive and master stop switch. Install the switch between the external fuse and AC power input as shown.

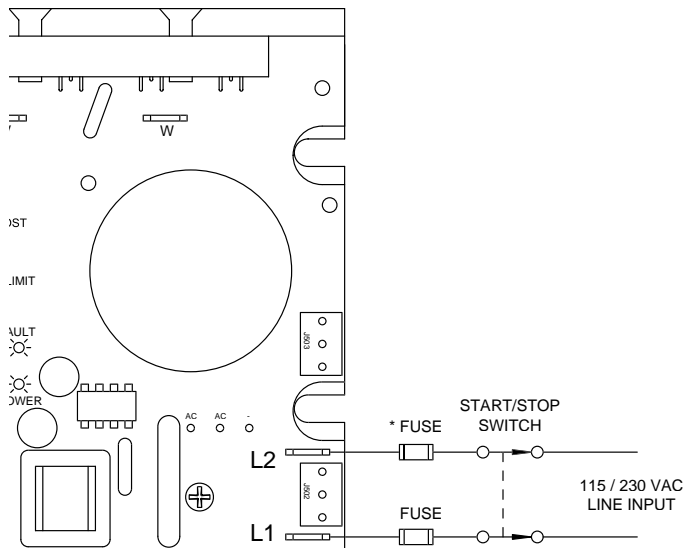

* Do not add fuse
to L2 unless line
voltage is 230 VAC.

Figure 12. AC Line and Fuse Connections for Single Voltage FHP Series Drives

Doubler FHP Series Drives (175319, 175310, 175311)



Warning



Do not connect 230 VAC line input when the drive is set for 115 VAC input. This will result in severe damage to the motor and drive, and can lead to explosion and/or injury. Check jumper settings before connecting AC power input.

Connect AC power input to L1 and L2 as shown in Figure 13 and 14 (pages 25 & 26), depending on your power needs.

NOTE: Doubler drives are equipped with a voltage-doubling feature, which converts a 115 VAC input to a 230 VAC output, for use with 230V motors. The drive output current rating remains the same. Use caution when connecting this output.

- If the input voltage is **115 VAC** and the desired output voltage is 230 VAC (voltage doubler mode), set 115V/230V jumper as shown in Figure 13 (page 25). A line fuse may be added to L2.
- If the input voltage is **230 VAC** and the desired output voltage is 230 VAC (no voltage doubler), set 115V/230V jumper as shown in Figure 14 (page 26). Add a line fuse to L1 and L2. Do not use the voltage doubler feature with 230 VAC line voltage.

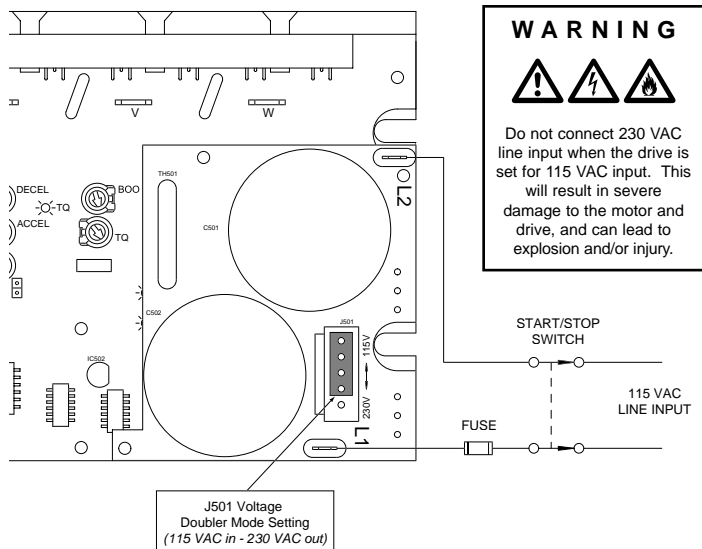

Figure 13. AC Line and Fuse Connections for Doubler FHP Series Drives (Voltage Doubler Mode)

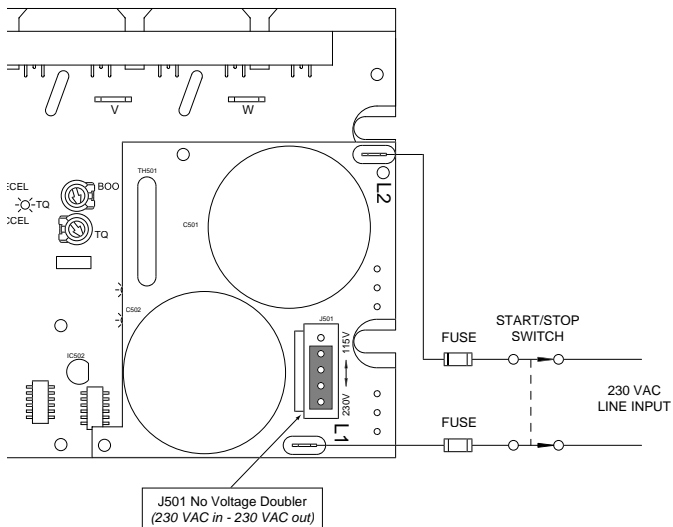

Figure 14. AC Line and Fuse Connections for Doubler FHP Series Drives (Not in Voltage Doubler Mode)

Motor connections (all FHP-series controls)

Single-phase operation

For single-phase operation, connect the motor as shown in Figure 15 (page 28). Ensure that the prewired capacitor and its associated motor coil are connected to terminals U and V as shown. This connection may be internal if using a 2-wire motor. If the motor has three leads, you must make this connection yourself.

To reverse a single phase split capacitor motor, connect the motor as shown in Figure 16 (page 29). The motor starter cap must be removed from the circuit.

Three-phase operation

Connect a three-phase motor to terminals U, V and W as shown in Figure 17 (page 30).

NOTE
This connection may be internal to the motor (2 wire leads). If not, you must make this connection yourself.

MOTOR WINDINGS
PREWIRED RUN CAPACITOR

DO NOT use a DIRECTION switch with this set-up. See Figure 16 on Page 29 for setup using a DIRECTION switch.

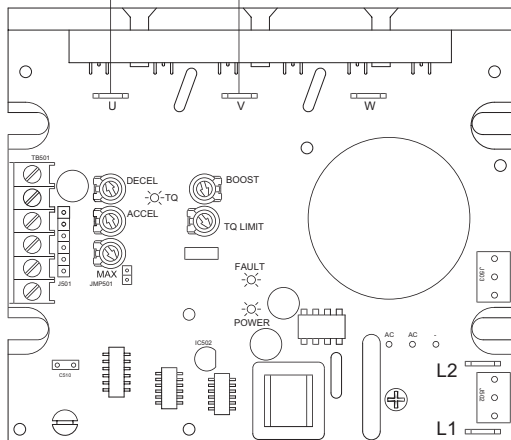
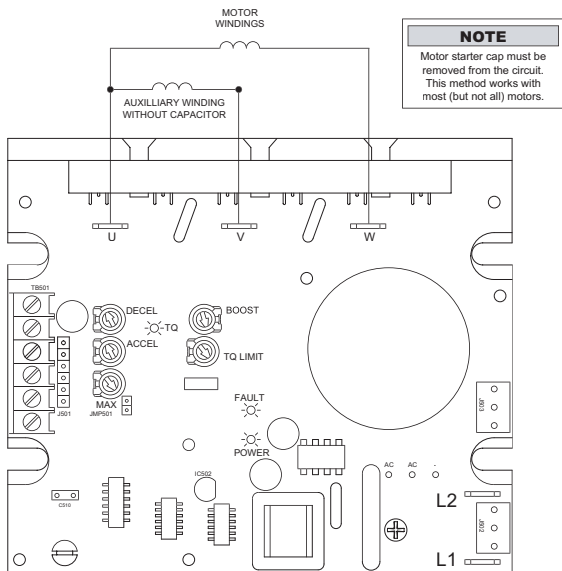

Figure 15. Motor Connections for Single-Phase Operation (Motor With Pre-Wired Capacitor)



**Figure 16. Motor Connections for Single-Phase Operation
(Configured for use with DIRECTION switch)**

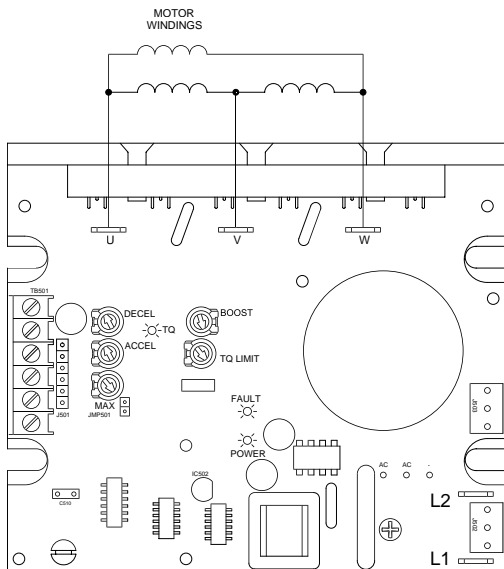

Figure 17. Motor Connections for Three-Phase Motors

Speed Adjust Potentiometer Connections

Connect a speed adjust potentiometer to terminals S1, S2 and S3. Make sure the potentiometer is connected so that the motor speed will increase as the wiper (S2) is turned clockwise (CW). See Figure 18 below.

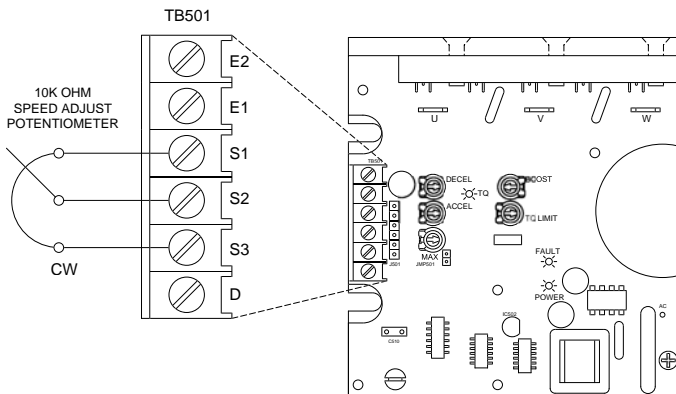

Figure 18. Speed Adjust Potentiometer Connections to TB501

Voltage Follower Connections

Instead of using a speed adjust potentiometer, the drive may be wired to follow a 0 - 5 VDC isolated voltage signal (Figure 19). Connect the signal input (+) to S2 and signal common (-) to S1. Make no connection to S3. A potentiometer can be used to scale the analog input voltage. The FHP-PCM adder board may be used to scale and isolate an analog input voltage (see Page 35).

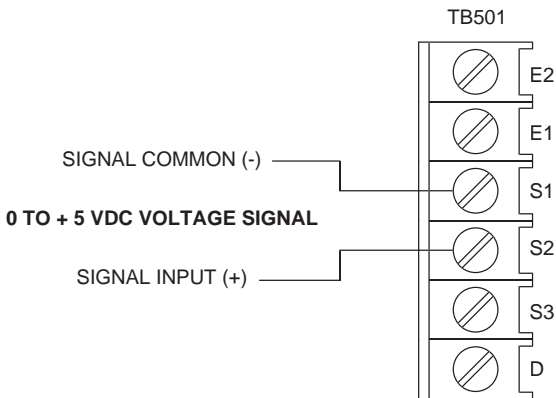

Figure 19. Voltage Follower connections

Signal and Optional Switch Connections

All signal and switch connections are made at TB501. Terminal block orientation and terminal names are identical for all FHP series drives. Use 20 - 24 AWG wire for speed adjust potentiometer and switch connections.

ENABLE/DISABLE switch

Connect a single-pole, single-throw ENABLE/DISABLE switch between the ENABLE (E2) and COMMON (E1) terminals as shown. Open the switch to disable the drive and coast to a stop. Close the switch to accelerate to set speed at a rate controlled by the ACCEL trimpot.

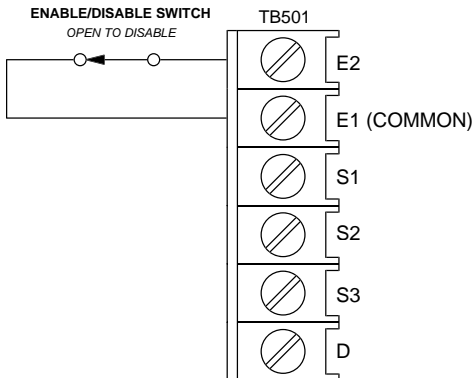

Figure 20. Enable / Disable Switch connections to TB501

DIRECTION (D) switch

Connect a single-pole, single-throw DIRECTION switch between the (D) and COMMON (E1) terminals as shown in Figure 21 below. Opening the switch will cause the motor to rotate in the forward direction; closing the switch will reverse motor rotation.

The drive will decelerate the motor to a stop, (at the DECEL trimpot setting), before reversing, so there is no need to wait for the motor to coast to a stop before changing direction.

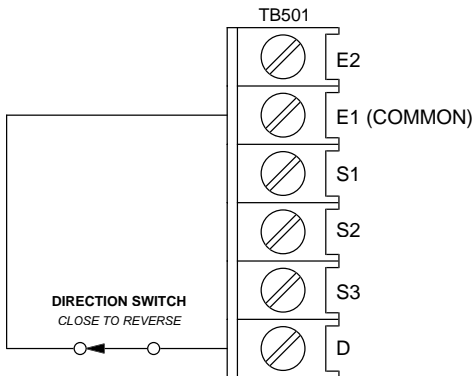

Figure 21. Signal and Optional Switch Connections

Voltage or Current Follower (PCM models)

PCM series drives can be configured to follow a grounded (non-isolated) voltage or current signal. To configure the drive to follow a voltage or current signal, connect the signal leads to the S1 and S2 terminals on TB501. Ensure that the following jumper terminals are properly set:

JMP501 Input Range Settings

Set jumper in position 1 for 0 - 5 VDC signal input.

Set jumper in position 2 for 0 - 10 VDC signal input.

Set jumper in position 3 for 4 - 20 mA signal input.

JMP502 Input Type

Jumper pins 1 & 2 for Voltage follower mode.

Jumper pins 2 & 3 for Current follower mode.

See Figure 22 on page 36 for jumper locations and terminal connections.

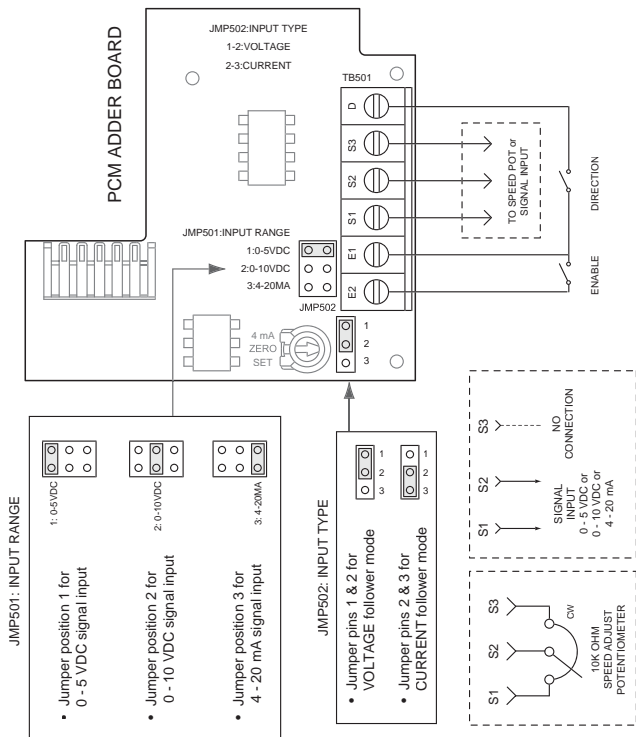

Figure 22. PCM jumper locations and terminal connections

Operation



Warning



Dangerous voltages exist on the drive when it is powered, and up to 60 seconds after power is removed and the motor stops. BE ALERT. High voltages can cause serious or fatal injury.

Do not change jumper settings with power applied. Ensure that jumper settings are compatible with the motor being controlled.



Voltage Input Warning for Doubler Drives



DO NOT connect 230 VAC line input when the drive is set for 115 VAC input. This will result in severe damage to the motor and drive, and possible explosion and/or injury.

Voltage Doubler



Warning

DO NOT connect 230 VAC line input when drive is set for 115 VAC input. This will result in severe damage to the motor and drive, and possible explosion or severe injury.

Doubler drives are equipped with a unique voltage-doubling feature, for use when 230 VAC input voltage is not available. This feature converts a 115 VAC input to a 230 VAC output, for use with 230V motors. The drive output current rating remains the same.

Refer to Page 24 for connection information. Use extreme caution when connecting this feature. Incorrect use of this feature may result in fire and serious injury.

Startup



Warning

DO NOT change jumper settings with power applied. Ensure that jumper settings are compatible with the motor being controlled.

Before applying power, verify that no conductive material is present on the printed circuit board.

1. Verify that no conductive material is present on the PCB.
2. Verify that the correct voltage is connected to the inputs before applying power. **DO NOT CONNECT 230 VAC line voltage to a 115 VAC drive.** Applying power in this manner will damage the motor and drive.
3. Set the speed adjust potentiometer to zero (full CCW).
4. Set the DIRECTION switch (if installed) to the desired direction. If no switch is installed, add or remove a jumper across the (D) and (E1) terminals, as required.
5. Set the ENABLE/DISABLE switch (if installed) to ENABLE, or short the ENABLE (E2) and (E1) terminals on TB501.
6. Apply 115 or 230 VAC, 50/60 Hz, single-phase power to the drive. The green POWER LED will come on after an initial delay of 1 - 2 seconds. If the POWER LED does not light, check the external line fuses to ensure that they are properly installed and not blown.

7. If you attempt to startup and the yellow TQ LED comes on, the control has entered torque limit mode. To avoid this occurrence, you may:
 - a. increase the torque limit setting*, or
 - b. lengthen the acceleration time enough to accommodate the needed starting torque by adjusting the ACCEL trimpot.

* Do not set the torque limit setting above 150% of the motor's nameplate current rating.

To reverse motor direction:

To reverse the direction of motor shaft rotation while the motor is running, set the DIRECTION switch to the opposite position. If no DIRECTION switch is installed, open or short the (D) and (E1) terminals on TB501, as required.

When a new direction is selected, there is no need to open the enable input. The control will automatically decelerate the motor to zero speed, reverse direction, and then accelerate the motor back to the set speed. Acceleration and deceleration rates are controlled by the ACCEL/DECEL trimpot settings. If quicker reversing is needed refer to applications notes section (page 51) for further detail.

Starting and stopping methods

To coast the motor to a stop

Open the ENABLE/DISABLE switch, or remove the jumper between the ENABLE (E2) and COMMON (E1) terminals of TB501. Refer to the Application Notes section (page 51) for instructions on switch installation.

Thermal protection of the motor

The enable input can also act as a motor thermal protection circuit for motors having a built-in thermal protector. These thermal protectors are operated only by motor heat and open the enable circuit when the motor reaches a temperature capable of causing damage to the motor winding.

Normally, these thermal protectors automatically close the circuit when the motor has cooled to a safe temperature. In operation, when the drive is disabled, or when the motor overheats, the thermal protector opens the circuit. See Figure 23 (page 42).

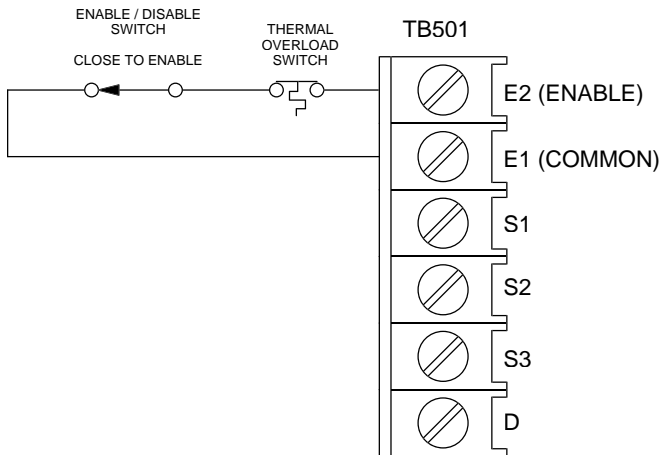

Figure 23. Thermal Overload Switch with Optional Enable / Disable Switch

Line starting and line stopping



Warning

LEESON strongly recommends the installation of a master power switch in the voltage input line (see Power and Fuse connections, page 22). The switch contacts should be rated at a minimum of 200% of motor nameplate current and 250 volts.

Line starting and line stopping (applying and removing AC voltage input) is not recommended and should be used for emergency stopping only. When AC voltage input is applied to the drive, the motor accelerates to the speed set by the speed adjust potentiometer. When AC voltage input is removed, the motor coasts to a stop. To “jog” a motor, install a normally-open pushbutton switch on the ENABLE input.

Calibration



Warning

Dangerous voltages exist on the drive when it is powered, and up to 60 seconds after power is removed and the motor stops. When possible, disconnect the voltage input from the drive before adjusting the trimpots. If the trimpots must be adjusted with power applied, use insulated tools and the appropriate personal protection equipment. BE ALERT. High voltages can cause serious or fatal injury.

The FHP series has five user-adjustable trimpots. Each drive is factory calibrated to its maximum current rating. Re-adjust the calibration trimpot settings to accommodate lower current motors. See Figure 24 (page 45) for FHP series trimpot location.

All adjustments increase with clockwise (CW) rotation and decrease with counter-clockwise (CCW) rotation. Use a non-metallic screwdriver for calibration. Each trimpot is identified on the printed circuit board.

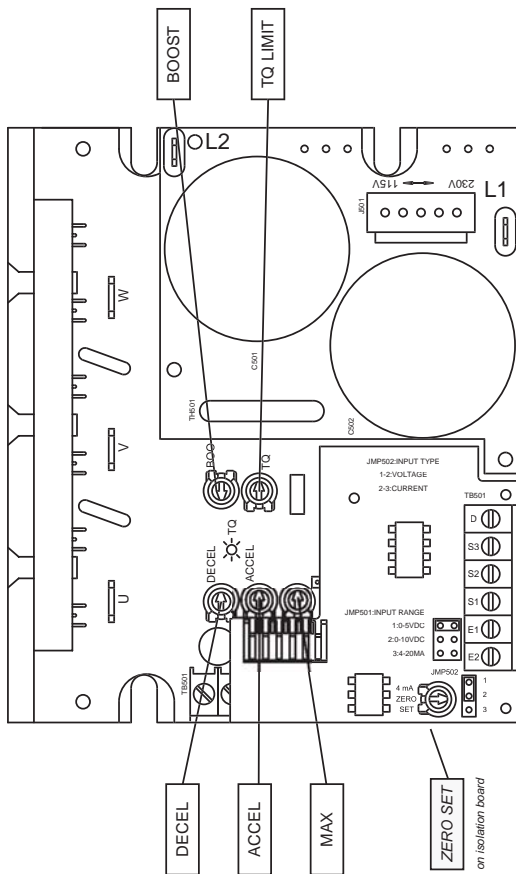

Figure 24. FHP Series Calibration Trimpot Layout

Calibration Procedure Setup for 60 Hz Motors:

1. Set the ENABLE switch to the DISABLE (open) position. If no switch is installed, remove the jumper between the (E2) and (E1) terminals of TB501.
2. Set the DIRECTION switch to the FWD (open) position. If no switch is installed, remove the jumper between the (D) and (E1) terminals of TB501.
3. Set all trimpots except TQ LIMIT and MAX fully counterclockwise (CCW).
4. Set the TQ LIMIT trimpot to maximum (full CW).
5. Set the speed adjust potentiometer to zero (full CCW).
6. Calibrate the trimmer pots as follows:

MAXIMUM SPEED (MAX SPD)

Rotate the speed adjust potentiometer full CW. Using a hand-held tachometer or analog frequency meter as a reference, adjust the MAX trimpot until the desired speed or frequency is reached.

TORQUE LIMIT (TQ LIMIT)



Warning

Although the TQ LIMIT trimpot can be set up to 150% of the drive nameplate rating, continuous operation beyond the drive nameplate rating may cause damage to the motor and/or drive.

1. With no power applied to the drive, connect a (true RMS) ammeter in series with one of the motor leads.
2. Set the TQ LIMIT trimpot to full CCW.
3. Carefully lock the motor shaft. Ensure that the motor is firmly mounted.
4. Apply line power. The motor should be stopped.
5. Set the speed adjust potentiometer or reference signal to maximum speed. The motor should remain stopped.
6. Slowly rotate the TQ LIMIT trimpot clockwise (CW) until the ammeter reads 120% of maximum motor current.
7. Set the speed adjust potentiometer or reference signal to zero speed.
8. Remove power from the drive.
9. Remove the lock from the motor shaft.
10. Remove the ammeter in series with the motor lead.

ACCELERATION (ACCEL)

1. Set the speed adjust potentiometer to zero (full CCW) and wait for the motor to come to a stop (or minimum speed).
2. Set the speed adjust potentiometer or reference signal to maximum speed (full CW) and note the time the motor takes to accelerate to maximum speed.
3. If the acceleration time differs from the desired time, adjust the ACCEL trimpot until the desired time is reached. Rotating the ACCEL trimpot CW increases the acceleration time.

DECELERATION (DECEL)

1. Set the speed adjust potentiometer to maximum (full CW) and wait for the motor to come to maximum speed.
2. Set the speed adjust potentiometer to minimum speed (full CCW) and note the time the motor takes to decelerate to minimum speed.
3. If the deceleration time differs from the desired time, adjust the DECEL trimpot until the desired time is reached. Rotating the DECEL pot CW increases the deceleration time.

BOOST

The boost trimpot is used to increase motor torque at low speeds. The minimum setting is sufficient for most applications and does not need to be adjusted. If the motor stalls or runs erratically at very low speeds (below 10 Hz), the boost trimpot may need adjustment.

1. Run the motor at the lowest continuous frequency/speed required.
2. Monitor the motor phase current (with a true RMS meter) while very slowly turning the BOOST trimpot CW until the motor operates properly, or 100% of the motor nameplate current is reached.

NOTE: Use the absolute minimum amount of BOOST necessary to achieve proper motor operation. Improper use of the BOOST feature may cause motor and/or drive overheating and failure. If proper motion operation cannot be achieved with the above procedure, please contact your LEESON representative for assistance.

Calibration Procedure Conclusion

1. Set the speed adjust potentiometer to zero (full CCW).
2. Disable the drive by opening the ENABLE/DISABLE switch or removing the jumper from TB501 (E2) and (E1) terminals.
3. Remove power to the motor and drive. Calibration is now complete.

Application Notes

Independent adjustable speeds with DIR switch

Replace the speed adjust potentiometer with two single-pole multi-position switches, and two or more potentiometers in parallel, with a total parallel resistance of 10K ohms. Figure 25 shows the connection of two independent speed adjust potentiometers that can be mounted at two separate operating stations.

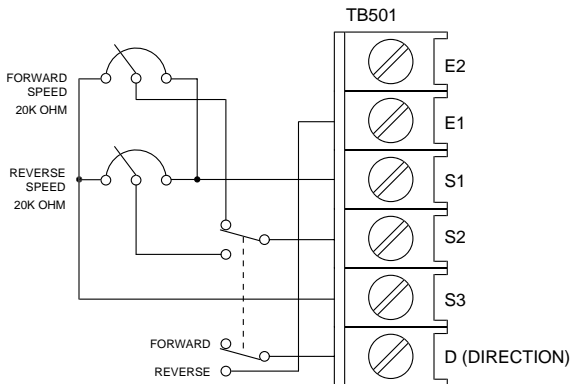

Figure 25. Independent Adjustable Speeds

RUN/JOG switch

Using a RUN/JOG switch is recommended in applications where quick stopping is not needed and frequent jogging is required. Use a single-pole, two-position switch for the RUN/JOG switch, and a single-pole, normally open, momentary operated pushbutton for the JOG pushbutton.

Connect the RUN/JOG switch and JOG pushbutton to terminal board TB501 as shown in Figure 26. The motor coasts to a stop when the RUN/JOG switch is set to JOG. Press the JOG pushbutton to jog the motor. Return the RUN/JOG switch to RUN for normal operation.

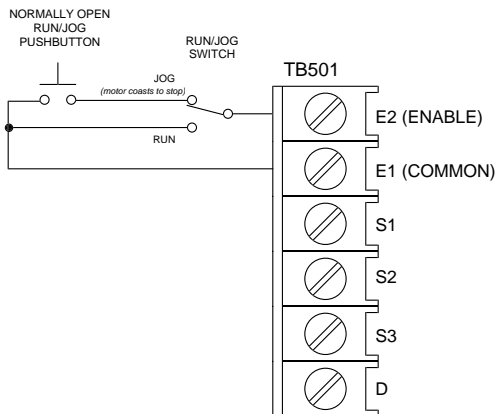

Figure 26. RUN/JOG Switch

Single speed potentiometer control of multiple motors



Warning

The combined current draw of all motors must not exceed the current rating of the drive.

The FHP series of controls is capable of operating up to eight 3-phase motors simultaneously. All motors must be of the same type and must control similar loads. Connect each motor as shown in Figure 27 below.

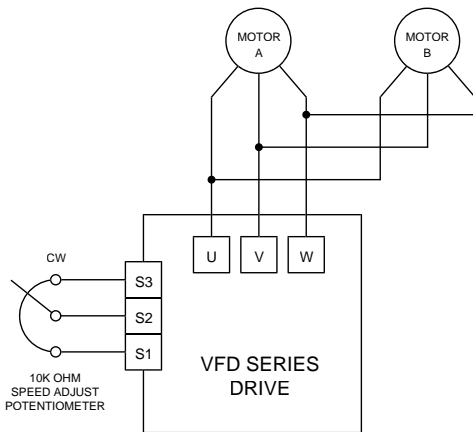

Figure 27. Single Speed Potentiometer Control of Multiple Motors

Quick Reversing

To reverse the direction of motor shaft rotation, install a DPDT center off switch as shown below (Figure 28). The drive will brake the motor before reversing, so there is no need to wait for the motor to coast to a stop before changing direction.

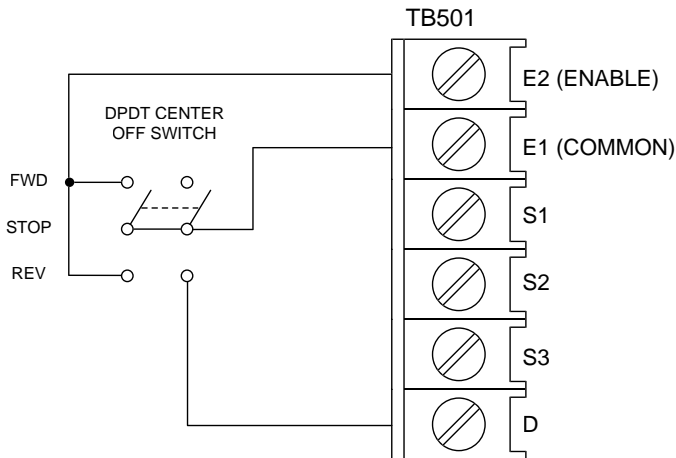

Figure 28. FHP Quick Reversing

Troubleshooting



Warning

Dangerous voltages exist on the drive when it is powered, and up to 60 seconds after power is removed and the motor stops. When possible, disconnect the voltage input from the drive while troubleshooting. BE ALERT. High voltages can cause serious or fatal injury.

Before troubleshooting

Perform the following steps before starting any procedure in this section:

- Disconnect AC voltage input from the drive. Wait 60 seconds for power to discharge. The green POWER LED will blink while power is discharging.
- Check the drive closely for damaged components.
- Check that no wire, chips, or other foreign material has become lodged on the printed circuit board.
- Verify that every connection is correct and in good condition.

- Verify that there are no short circuits or grounded connections.
- Check that the drive's rated phase current and RMS voltage are consistent with the motor ratings.

For additional assistance, contact your local Leeson distributor, or the factory direct by telephone at:

TEL: (262) 377-8810 or FAX: (262) 377-0090

Diagnostic LEDs

LEESON FHP Series drives are equipped with diagnostic LED's to assist the user in troubleshooting and monitoring equipment status while in use. Refer to Figure 29 (page 58) for diagnostic LED locations.

POWER LED

The green POWER LED is on when AC line voltage is applied and the control's low-voltage power supply is operational.

FAULT LED

The red FAULT LED turns on when the drive output is locked out or not ENABLED and any one of the following fault conditions occur:

1. Overvoltage
 - FHP 230AC controls: DC bus exceeds 400 VDC
 - FHP 115AC controls: DC bus exceeds 200 VDC
2. Undervoltage
 - FHP 230AC controls: DC bus drops below 200 VDC
 - FHP 115AC controls: DC bus drops below 100 VDC
3. Instantaneous Overcurrent Trip - Inverter output current has exceeded safe levels.

Note: The FAULT condition must be reset using the ENABLE function of the FHP (opening and closing the ENABLE input).

TQ LIMIT LED

The yellow TQ LIMIT LED is on when the drive output current exceeds the threshold set by the TQ LIMIT trimpot. When the TQ LIMIT LED turns on, shut down the motor and drive by disabling or removing power. Check the motor to make sure it is not jammed or overloaded. The TQ LIMIT trimpot may need to be recalibrated. See the Calibration section (page 47) for information on calibrating the TQ LIMIT trimpot.

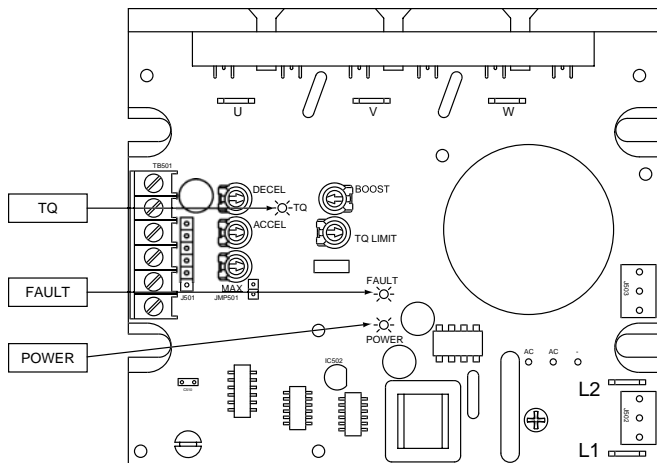

Figure 29. FHP Series diagnostic LED locations

Problem	Possible Cause	Suggested Solution
External line fuse blows	<ol style="list-style-type: none"> 1. Line fuses are the wrong size. 2. Motor or motor cable is shorted to ground. 3. Nuisance tripping caused by a combination of ambient conditions and high-current spikes (i.e. reversing). 	<ol style="list-style-type: none"> 1. Check that line fuses are properly sized for the motor being used. 2. Check motor cable and motor for shorts. 3. Add a blower to cool the drive components; increase TQ LIMIT settings (page 47).
External line fuse does not blow, but the motor does not run	<ol style="list-style-type: none"> 1. Speed adjust potentiometer or voltage input signal is set to zero speed. 2. Speed adjust potentiometer or voltage input signal is not properly connected to drive input; connections are open. 	<ol style="list-style-type: none"> 1. Increase the speed adjust potentiometer setting or voltage input signal. 2. Check connections to input. Verify that connections are not open.

Problem	Possible Cause	Suggested Solution
External line fuse does not blow, but the motor does not run (cont.)	<ol style="list-style-type: none">3. Drive is "tripped" off or has gone into thermal overload.4. Drive has been disabled.5. Drive is in current limit.6. Drive is not receiving AC voltage input.7. Motor is not connected.	<ol style="list-style-type: none">3. Disable, then re-enable the drive.4. Ensure that ENABLE (EN) and COM terminals are properly connected.5. Verify that motor is not jammed. Increase TQLIM setting if it is set too low (page 47).6. Apply AC line voltage to L1 and L2.7. Connect motor to drive outputs U, V and W.
Motor runs too slow or too fast at set speed	<ol style="list-style-type: none">1. MAX SPD trimpot is not calibrated correctly.	<ol style="list-style-type: none">1. Calibrate MAX SPD trimpot (page 46).

Problem	Possible Cause	Suggested Solution
Motor will not reach the desired speed	<ol style="list-style-type: none"> 1. MAX SPD setting is too low. 2. Nominal input voltage may be too low for motor 3. Motor is overloaded. 	<ol style="list-style-type: none"> 1. Increase MAX SPD setting (page 46). 2. Compare motor voltage to input voltage; replace motor if necessary 3. Check motor load. Resize the motor or drive if necessary.
Motor pulsates or surges under load	<ol style="list-style-type: none"> 1. Motor “bouncing” in and out of torque limit. 	<ol style="list-style-type: none"> 1. Make sure motor is not undersized for load; adjust TQ LIM setting CW (page 47).
Motor does not reverse	<ol style="list-style-type: none"> 1. Defective DIRECTION switch connection. 2. Reversing circuit not working properly. 	<ol style="list-style-type: none"> 1. Check DIRECTION switch connection. 2. Check reversing circuit by shorting TB501 (D) terminal to (E1) terminal with jumper wire.

Problem	Possible Cause	Suggested Solution
TQ is unsatisfactory at high speeds.	<ol style="list-style-type: none"><li data-bbox="397 268 664 290">1. TQ LIMIT set too low.<li data-bbox="397 359 653 411">2. Load may exceed rating of motor/drive.<li data-bbox="397 626 664 709">3. Nominal input voltage may be too low for motor.	<ol style="list-style-type: none"><li data-bbox="703 268 921 321">1. Check TQ LIM setting (page 41).<li data-bbox="703 359 938 590">2. "Fix" load (i.e., straighten mounting, coupling, etc.); or replace motor and drive with motor and drive rated for higher horsepower.<li data-bbox="703 626 938 740">3. Compare motor voltage to input voltage. Replace motor if necessary.

Optional C510 Capacitor Kit (p/n: 175325)

In some applications, lowering carrier frequency reduces switching losses and increases bearing life in some motors. LEESON provides an optional capacitor kit for lowering the carrier frequency.

The default carrier frequency on FHP controls is 16kHz. Using one of the capacitors supplied in the kit, the carrier frequency can be lowered to a range of 12kHz to 4kHz.

Note: Audible noise will increase when the carrier frequency is lowered.

To lower the carrier frequency on all FHP controls, install one of the following 2-pin capacitors (C510) on the bottom board:

LABEL ON CAPACITOR	FREQUENCY	VALUE
3n3J	12kHz	0.0033uF
6n8	10kHz	0.0068uF
10n	8kHz	0.01uF
33n	4kHz	0.033uF

See Figure 30 on page 64 for C510 location and installation instructions.

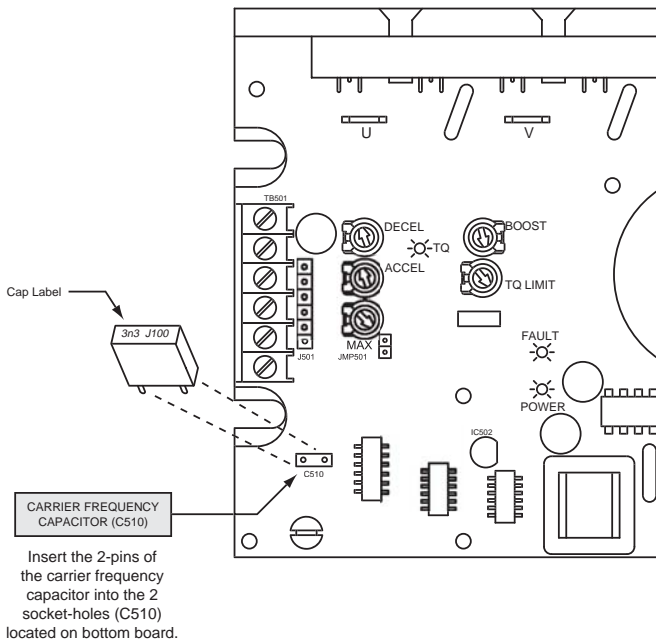

Figure 30. Carrier frequency capacitor location

Replacement Parts

Replacement parts are available from LEESON Electric and its distributors for this drive series.

Table 2. Replacement Parts

Potentiometer Kit	10K ohm, 5W Potentiometer
175325 Capacitor Kit	12 kHz Capacitor 10 kHz Capacitor 8 kHz Capacitor 4 kHz Capacitor
175324 PCM Kit	PCM Adder Board (1) PCB Standoffs (2) Jumper (1) 6-Pin Header (1) Shoulder Washer (1) 0.578" Nylon Spacer (1) 6-32 x 1-15/16" Phillips Screw (1)

DISCLAIMER

The information and technical data in this manual are subject to change without notice. LEESON Electric makes no warranty of any kind with regard to this material, including, but not limited to, the implied warranties of merchantability and fitness for a particular purpose. LEESON Electric assumes no responsibility for any errors that may appear in this manual and makes no commitment to update or to keep current the information in this manual.



2100 Washington Street
Grafton, WI 53024-0241, U.S.A.
TEL: (262) 377-8810 FAX: (262) 377-9025

Document number 250-0356, Revision 2
Printed in the U.S.A – September 2004