



US Army Corps  
of Engineers®

PDC-TR 10-02  
19 April, 2012

## PROTECTIVE DESIGN CENTER TECHNICAL REPORT (PDC-TR)

---

# **BLAST RESISTANT DESIGN METHODOLOGY FOR WINDOW SYSTEMS DESIGNED STATICALLY AND DYNAMICALLY**

APPROVED FOR PUBLIC RELEASE; DISTRIBUTION UNLIMITED

**PROTECTIVE DESIGN CENTER TECHNICAL REPORT (PDC-TR)**  
**BLAST RESISTANT DESIGN METHODOLOGY FOR WINDOW SYSTEMS**  
**DESIGNED STATICALLY AND DYNAMICALLY**

Any copyrighted material included in this PDC-TR has been approved by the copyright owner and is identified at its point of use. Use of the copyrighted material apart from this PDC-TR must have the permission of the copyright holder.

U.S. ARMY CORPS OF ENGINEERS (Preparing Authority)

Record of Changes

<b>Change No.</b>	<b>Date</b>	<b>Location</b>

## **FOREWORD**

UFC 4-010-01 provides baseline minimum levels of protection for all DOD inhabited buildings that must comply with the Standards when they meet specific “triggers”. Those levels of protection are achieved using conventional construction when the applicable standoff distance is provided for the construction type being considered. When using the Design Criteria Development Procedure from UFC 4-020-01, a facility may require a higher level of protection and/or may have to be designed for a specified set of Design Basis Threats (DBT) that were defined during the planning team’s analysis of that facility. In all cases the window systems and their supporting structural elements are required to be analyzed and designed for the Minimum Standards and any defined DBT’s when they are based on a set of specified charge weights and standoff distances. This PDC TR does not cover the design and analysis of windows subjected to ballistic, fragment impact, and forced entry loadings.

Structural engineers need guidance for the design of window systems and their supporting structural elements to resist the airblast associated with terrorist explosive threats, whether it may be for the minimum requirements or where higher levels of protection are required and/or where more severe threats need to be considered.

The two prevalent methods used in DoD to design window systems and their supporting structural elements to resist the airblast loading from explosive threats are a static approach using ASTM F 2248/E 1300 or a dynamic approach. The preferred DoD method is the dynamic method as it provides a more optimized system.

The U.S. Army Corps of Engineers Protective Design Center (PDC) has provided the design methods contained in this report as design guidance for structural engineers.

This information is furnished by the United States Government and is accepted and used by the recipient with the express understanding that the United States Government makes no warranties, expressed or implied, concerning the accuracy, completeness, reliability, usability, or suitability for any particular purpose of the information and data contained in this document, and the United States Government shall be under no liability whatsoever to any person by reason of any use made thereof.

**This Page Intentionally Left Blank**

## CONTENTS

CONTENTS .....	i
LIST OF TABLES.....	iv
LIST OF FIGURES.....	iv
CHAPTER 1 INTRODUCTION.....	1
1-1 BACKGROUND .....	1
1-2 PURPOSE AND SCOPE.....	1
1-3 APPLICABILITY .....	2
1-4 GENERAL.....	2
1-4.1 Performance of Protective Glazing in Occupied Structures .....	2
1-4.2 Protective Glazing Systems and Supporting Structural Elements .....	2
1-4.3 Design Procedures.....	2
1-4.4 Specifications .....	3
1-5 REFERENCES.....	3
CHAPTER 2 THREATS AND LEVELS OF PROTECTION .....	5
2-1 BLAST THREAT .....	5
2-1.1 Blast Threat Severity Levels.....	5
2-1.2 Standoff Distance.....	5
2-2 LEVELS OF PROTECTION AND PERFORMANCE CRITERIA .....	6
2-2.1 Building Component Levels of Protection .....	6
2-2.2 Glazing Levels of Protection.....	8
CHAPTER 3 GLAZING PRODUCTS AND CONSTRUCTIONS.....	11
3-1 GLAZING CONSTRUCTIONS .....	11
3-1.1 Monolithic Glass.....	11
3-1.2 Laminated Glass .....	11
3-1.3 Insulating Glass Units .....	11
3-1.4 Composites .....	11
3-1.5 Glass Block .....	12
3-2 GLAZING PRODUCTS .....	12
3-2.1 Annealed Glass.....	12
3-2.2 Heat Strengthened and Fully Tempered Glass .....	12
3-2.3 Plastic Glazing .....	13
3-2.4 PVB Interlayers for Laminated Glass .....	14
3-2.5 Specialty Interlayers for Laminated Glass.....	14
3-2.6 Glazing Supported by a Frame .....	15
3-3 GLAZING STRENGTH AND GLASS PROBABILITY OF FAILURE.....	15
3-4 BLAST RESISTANT GLAZING CONSIDERATIONS.....	16
3-5 TYPICAL MAKEUPS AND SYSTEMS .....	16
3-5.1 Punched Windows .....	17
3-5.2 Ribbon Windows .....	17
3-5.3 Storefronts.....	18
3-5.4 Curtain-Walls.....	19

3-5.5	Butt-Joint Glazing Systems .....	19
3-5.6	Structural Silicone Glazing Systems .....	20
3-5.7	Glazing in Doors.....	20
3-5.8	Operable Window Systems .....	20
3-5.9	Non-Traditional Systems .....	20
3-6	WINDOWS DESIGNED TO RESIST ENVIRONMENTAL LOADINGS .....	20
CHAPTER 4	DESIGN APPROACHES.....	21
4-1	GENERAL.....	21
4-2	STATIC DESIGN APPROACH.....	21
4-2.1	Alternate Glazing.....	22
4-2.2	Applicable Levels of Protection .....	22
4-2.3	Applicable Charge Weights .....	22
4-2.4	Non-Reflected Pressures .....	22
4-2.5	Glazing.....	22
4-2.6	Frame Members.....	24
4-2.7	Bite.....	25
4-2.8	Connections .....	26
4-2.9	Supporting Structural Elements.....	27
4-2.10	Skylights.....	29
4-3	DYNAMIC DESIGN APPROACH.....	29
4-3.1	Alternate Glazings.....	29
4-3.2	Applicable Levels of Protection .....	30
4-3.3	Applicable Charge Weights and Blast Parameters.....	30
4-3.4	Glazing.....	31
4-3.5	Frame Members.....	32
4-3.6	Bite and Engagement.....	33
4-3.7	Frame Connections to Supporting Structural Elements .....	33
4-3.8	Supporting Structural Elements.....	33
4-3.9	Skylights.....	34
GLOSSARY	.....	35
APPENDIX A	SBEDS DYNAMIC DESIGN PROCEDURE.....	43
A-1	DESIGN OF WINDOW USING SBEDS-W.....	43
A-1.1	Glazing Design Properties.....	43
A-1.2	Design Requirements.....	44
A-1.3	Results Summary.....	44
A-1.4	Results Tab.....	45
A-2	DESIGN OF WINDOW FRAME USING SBEDS-W .....	46
A-2.1	Mullion Properties .....	46
A-2.2	Design Requirements.....	46
A-2.3	Results Summary.....	47
A-2.4	Results Tab.....	48
A-3	DESIGN OF SUPPORTING STRUCTURE USING SBEDS .....	48
A-3.1	Results .....	48
A-3.2	Connection Design.....	48

APPENDIX B DESIGN EXAMPLES.....	51
B-1 INTRODUCTION.....	51
B-2 EXAMPLE 1 – SINGLE PANE WINDOW, STATIC DESIGN .....	51
B-3 EXAMPLE 2 – IGU WINDOW, STATIC DESIGN.....	53
B-4 EXAMPLE 3 – CURTAIN WALL, STATIC DESIGN .....	56
B-5 EXAMPLE 4 – IGU WINDOW, DYNAMIC DESIGN .....	59
B-6 EXAMPLE 5 – CURTAIN WALL, DYNAMIC DESIGN .....	64
B-7 EXAMPLE 6 – MASONRY SUPPORTING STRUCTURAL ELEMENT, STATIC DESIGN.....	66
B-8 EXAMPLE 7 – STEEL STUD SUPPORTING STRUCTURAL ELEMENT, STATIC DESIGN.....	68
B-9 EXAMPLE 8 – MASONRY SUPPORTING STRUCTURAL ELEMENT, DYNAMIC DESIGN .....	69
B-10 EXAMPLE 9 – STEEL STUD SUPPORTING STRUCTURAL ELEMENT, DYNAMIC DESIGN .....	72
APPENDIX C DESIGN AND ANALYSIS COMPUTER PROGRAMS.....	75
C-1 SBEDS-W .....	75
C-2 WINGARD PE .....	76
C-3 SBEDS.....	77

### LIST OF TABLES

Table 2-1 Threat Parameters .....	5
Table 2-2 Description of Building Component Damage.....	7
Table 2-3 Description of Types of Structural Components .....	7
Table 2-4 Description of Component Damage .....	8
Table 2-5 Description of Glazing and Hazards.....	9
Table 2-6 Level of Protection Comparisons .....	9
Table 4-1 Mullion Response Limits .....	32

### LIST OF FIGURES

Figure 2-1 Horizontal Standoff Distance.....	6
Figure 2-2 Slant Range and Angle of Incidence.....	6
Figure 3-1 Stress Distribution of Fully Tempered Glass.....	13
Figure 3-2 Channel and Captured glazing.....	15
Figure 3-3 Punched Windows .....	17
Figure 3-4 Ribbon Windows .....	18
Figure 3-5 Storefront System .....	18
Figure 3-6 Curtain Wall Windows.....	19
Figure 4-1 ASTM F 2248-09 Chart Used to Determine the 3-Second Load .....	23
Figure 4-2 Storefront Support Lengths .....	25
Figure 4-3 Curtain Wall Support Lengths .....	25
Figure 4-4 Illustration of Tributary Width Values .....	28
Figure B-1 Determination of 3-Second Duration Equivalent Design Load.....	51
Figure B-2 Determination of NFL for 1/4" laminated glass .....	52
Figure B-3 Determination of NFL for 5/16" laminated glass .....	53
Figure B-4 Determination of NFL for 1/4" monolithic glass.....	54
Figure B-5 Determination of NFL for 1/4" laminated glass .....	54
Figure B-6 Example 4 Window Input.....	59
Figure B-7 Example 4 Window Properties Input.....	60
Figure B-8 Example 4 Blast Parameter Input.....	61
Figure B-9 Example 4 Window Results Summary.....	61
Figure B-10 Aluminum Frame Section Properties .....	62
Figure B-11 Example 4 Mullion Input .....	62
Figure B-12 Example 4 Mullion Properties Input .....	63
Figure B-13 Example 4 Mullion Results Summary .....	63
Figure B-14 Aluminum Curtain Wall Section Properties .....	64
Figure B-15 Example 5 SBEDS input for primary mullion .....	65
Figure B-16 Example 5 SBEDS results for primary mullion.....	65
Figure B-17 Example 8 SBEDS Input.....	70
Figure B-18 Example 8 SBEDS Calculated Properties .....	70
Figure B-19 Example 8 SBEDS Output.....	71
Figure B-20 Example 9 SBEDS Input.....	72
Figure B-21 Example 9 SBEDS Output.....	73



## **CHAPTER 1 INTRODUCTION**

### **1-1 BACKGROUND**

Typically, glazing materials cover approximately 20 to 40 % of the wall area of DoD facilities in the form of windows and doors or skylights on the roof. While industry standards allow architects to design and specify these window systems for the appropriate wind and gravity loads, such procedures are normally inadequate when the windows are subjected to blast loadings. Therefore, the design and analysis of window systems subjected to blast loads falls upon the duties of a qualified structural engineer with experience in design of blast loaded components. This threat can be mitigated through proper selection of the glazing, design of the glazing framing and connections to the surrounding structural system, and through the proper design of surrounding structural supports and attachment of those structural supports to the remaining structure. Glazing, as used in the context of this PDC-TR, is the infill material used in windows, doors, and skylights that may be glass, plastic or a combination of the two.

It should be noted that while blast is a loading condition that needs to be considered it may not be the controlling loading scenario. Designers need to consider environmental loadings such as, hurricane, typhoon, tornado, and high impact conditions, before analyzing and designing for blast loadings. In some cases, the environmental loadings may govern the design of the glazing system. The design of glazing for such impact loads and for resistance to fragments, ballistics and forced entry is not addressed in this PDC TR.

Glazing designed using the provisions of UFC 4-010-01 will resist the applicable threats, but may experience local or uniform fracture and partial failure. The reason for allowing limited failure is because blast energy, when absorbed through glazing fracture and supporting structure movement, can result in a more economical system and imparts smaller loads to the rest of the structure while still minimizing the possibility of mass casualties.

Blast loads are highly non-linear both in terms of the rate of loading and response of the loaded component. This PDC-TR presents two design approaches that typically allow the engineer to address these non-linear loads and glazing assembly responses with readily available glazing constructions, framing and supporting structural materials, and their attachments. The two design methods are a dynamic design approach and the ASTM F 2248/E 1300 design approach for laminated glass glazing systems, herein referred to as the “static design approach”.

### **1-2 PURPOSE AND SCOPE**

The purpose of this PDC-TR is to present engineering guidelines and cost effective solutions for design of window systems to reduce their fragment hazards from blast loading. The guidelines and solutions are applicable for the different levels of protection for structures used to protect personnel and other assets. Threats considered include a

wide range of explosive threats varying from hand-placed devices to vehicle bombs. It does not address design for impact loads or resistance to blast fragments, ballistics or forced entry. Retrofit systems, such as polymer catcher panels, back-up windows installed on the interior side of existing windows, and systems defined as “alternative window treatments” in UFC 4-010-01, are also not addressed in the PDC-TR.

### **1-3 APPLICABILITY**

The protective measures described in this document are to be applied to meet Antiterrorism and Force Protection (ATFP) requirements for DoD owned and leased facilities that house personnel or other assets requiring protection against explosive threats.

### **1-4 GENERAL**

There are multiple aspects of a protective glazing system which need to be addressed in order to provide a system which will work properly and provide the appropriate protection.

#### **1-4.1 Performance of Protective Glazing in Occupied Structures**

When subjected to blast loads, glazing may fracture and fail. The goal of the design to mitigate blast threats for lower levels of protection is not to prevent the fracture or failure of the glazing but to mitigate the hazards associated with that failure; however, this is not the case for high level of protection.

The performance of the glazing system (glazing panels, framing, and all connections) and the supporting structural elements of the building (jamb, headers, and sills) is further defined by the assigned level of protection which will have a direct correspondence to hazard levels for personnel in building occupied spaces.

#### **1-4.2 Protective Glazing Systems and Supporting Structural Elements**

Design recommendations and procedures in this PDC-TR provide guidance for selection of glazing materials and constructions that will resist blast loading through fracture and energy absorption by the glazing. Frame members and their connections to cladding or structural elements must transfer the applied load into the remaining structure. For blast loaded elements, significant load is transferred to supporting elements and attachments as blast loads are generally considered to be uniformly applied over the element's tributary area.

#### **1-4.3 Design Procedures**

This PDC-TR identifies the preferred design procedures which are acceptable for varying levels of protection. There are other commonly recognized design procedures, which may also be acceptable so long as those procedures meet the intent of reducing the glazing hazards to the appropriate level of protection.

#### 1-4.4 Specifications

Unified Facilities Guide Specifications (UFGS) are a joint effort of the U.S. Army Corps of Engineers (USACE), the Naval Facilities Engineering Command (NAVFAC), the Air Force Civil Engineer Support Agency (AFCEA), and the National Aeronautics and Space Administration (NASA). UFGS are for use in specifying construction for the military services. These specifications can be found on the Whole Building Design Guide ([www.wbdg.org](http://www.wbdg.org)).

#### 1-5 REFERENCES

1. ACI 530, "Building Code Requirements for Masonry Structures", 2011
2. ASCE 59-11, "Blast Protection of Buildings", American Society of Civil Engineers, 2011
3. ASTM Standard E1300-09a, *Standard Practice for Determining Load Resistance of Glass in Buildings*, 2009
4. ASTM Standard F1642-04, *Standard Test Method for Glazing and Glazing Systems Subject to Airblast Loadings*, 2004
5. ASTM Standard F2248-09, *Standard Practice for Specifying an Equivalent 3-Second Duration Design Loading for Blast Resistant Glazing Fabricated with Laminated Glass*, 2009
6. PDC-TR 06-01, *Single Degree of Freedom Blast Design Spreadsheet (SBEDS) Methodology Manual*, 2006
7. PDC-TR 06-08, *Single Degree of Freedom Structural Response Limits for Antiterrorism Design*, 2006
8. Single degree of freedom Blast Effects Design Spreadsheet, U.S. Army Corps of Engineers Protective Design Center, 2006
9. Unified Facilities Criteria (UFC) 3-340-1, "Design and Analysis of Hardened Structures to Conventional Weapons Effects", 2002
10. Unified Facilities Criteria (UFC) 3-340-02, "Structures to Resist the Effects of Accidental Explosions", 2008
11. Unified Facilities Criteria (UFC) 4-010-01, "DoD Minimum Antiterrorism Standards for Buildings", 2012
12. Unified Facilities Criteria (UFC) 4-020-01, "DoD Security Engineering Facilities Planning Manual", 2008

**This Page Intentionally Left Blank**

## CHAPTER 2 THREATS AND LEVELS OF PROTECTION

### 2-1 BLAST THREAT

This PDC-TR addresses the design of glazing systems to resist terrorist conventional explosive devices. UFC 4-020-01 presents potential terrorist explosive considered in the design of DoD buildings.

The types of explosive devices covered in this PDC-TR include hand placed satchel, package bombs and vehicle borne improvised explosive devices (VBIEDs). These devices may be constructed using a variety of explosive materials (e.g., C4, TNT, ammonium nitrate and fuel oil. Explosive yield is measured according to their equivalence to a particular weight of TNT, which is referred to as TNT equivalent weight. The explosive weight categories chosen are based on historical precedent, concealability, and vehicle size.

#### 2-1.1 Blast Threat Severity Levels

Threat severity levels associated with defined DBT's are presented in Table 2-1 below.

Table 2-1 Threat Parameters

Aggressor Tactic	Threat Severity Level	Weapons	Tools Or Delivery Method
Moving and Stationary Vehicle Devices	Special Case	9,000 kg (19,800 lbs) TNT	18,000 kg / ~ 40,000 lbs truck
	Very High	2,000 kg (4,400 lbs) TNT, Fuel	7,000 kg / ~ 15,000 lbs truck
	High	500 kg (1,100 lbs) TNT, Fuel	2,500 kg / ~ 5,500 lbs truck
	Medium	250 kg (550 lbs) TNT, Fuel	1,800 kg / ~ 4,000 lbs car
	Low	100 kg (220 lbs) TNT	1,800 kg / ~ 4,000 lbs car
	Very Low	25 kg (55 lbs) TNT	1,800 kg / ~ 4,000 lbs car
Hand Delivered Devices	High	IID, IED (up to 25 kg/55 lbs TNT) & hand grenades (Mail bomb limited to 1 kg/2.2 lbs TNT)	None
	Medium	IID, IED (up to 1 kg/2.2 lbs TNT) & hand grenades	
	Low	IID	

Note: This table derived from UFC 4-020-01, Table 3-27.

#### 2-1.2 Standoff Distance

Standoff distance is a distance maintained between a building or portion thereof and the potential location for an explosive detonation. Usually standoff distance is measured horizontally from the center of an explosive device perpendicular to the point of interest on a building. This is shown in Figure 2-1.

Figure 2-1 Horizontal Standoff Distance

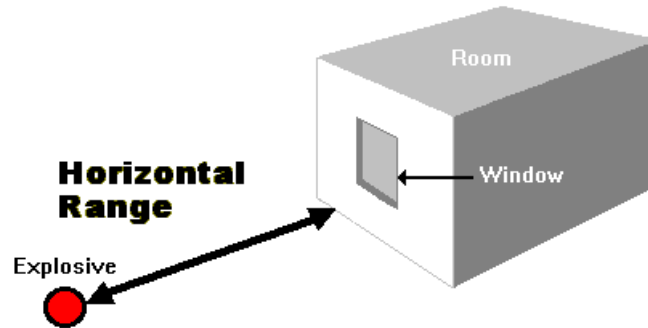

When a perpendicular distance is not appropriate, an angled measure, or slant range, may be used as long as it is unlikely that the threat could be placed within a closer distance than the slant range. Additionally, vertical standoff can be used in instances when analyzing the upper levels of a multistory building. Slant range and angle of incidence are shown in Figure 2-2.

Figure 2-2 Slant Range and Angle of Incidence

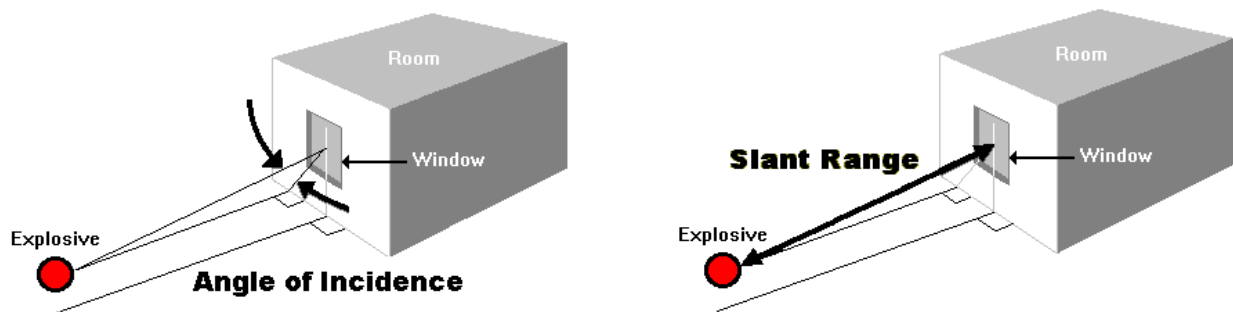

## 2-2 LEVELS OF PROTECTION AND PERFORMANCE CRITERIA

In addition to the blast tactic described above, the building level of protection (LOP) is the other element of design criteria needed for design. The building LOP defines the acceptable damage levels of building components and hazard from glazing components. Minimum levels of protection are specified in UFC 4-010-01. UFC 4-020-01 provides a method to determine if a higher building LOP is required.

### 2-2.1 Building Component Levels of Protection

Table 2-2 summarizes PDC TR-06-08 descriptions of the potential levels of protection in terms of building component damage.

Table 2-2 Description of Building Component Damage

Building Level of Protection	Descriptions of Potential Overall Building Component Damage
Below AT standards <sup>1</sup>	Severe Damage - Progressive collapse likely. Space in and around damaged area is unusable.
Very Low	Heavy Damage - Onset of structural collapse. Progressive collapse is unlikely. Space in and around damaged area is unusable.
Low	Unrepairable Damage - Progressive collapse will not occur. Space in and around damaged area is unusable.
Medium	Repairable Damage - Space in and around damaged area can be used and is fully functional after cleanup and repairs.
High	Superficial Damage - No permanent deformations. The facility is immediately operable.

1 - This is not a level of protection, and should never be a design goal. It only defines a realm of more severe structural response, and may provide useful information in some cases.

Supporting structural elements which frame the window opening are considered structural components. These components are categorized as primary, secondary, or non-structural components based on what type of member it is and what effect its loss would have on the rest of the structure. Component descriptions are shown in Table 2-3. Additionally, the level of protection assigned to a component is determined by the amount of damage it sees. Component damage descriptions are shown in Table 2-4. Both tables are extracted from PDC TR-06-08.

Table 2-3 Description of Types of Structural Components

Component	Description
Primary Structural	Members whose loss would affect a number of other components supported by that member and whose loss could potentially affect the overall structural stability of the building in the area of loss. Examples of primary structural components include: columns, girders, and other primary framing components directly or in-directly supporting other structural or non-structural members, and any load-bearing structural components such as walls.
Secondary Structural	Structural component supported by a primary framing component. Examples of secondary structural components include non-load bearing infill masonry walls, metal panels, and standing seam roofs.
Non-Structural	Components whose loss would have little effect on the overall structural stability of the building in the area of loss. Examples of non-structural components include interior non-load bearing walls, and architectural items attached to building structural components.

Table 2-4 Description of Component Damage

Component Damage Level	Description of Component Damage
Blowout	Component is overwhelmed by the blast load causing debris with significant velocities
Hazardous Failure	Component has failed, and debris velocities range from insignificant to very significant
Heavy Damage	Component has not failed, but it has significant permanent deflections causing it to be unrepairable
Moderate Damage	Component has some permanent deflection. It is generally repairable, if necessary, although replacement may be more economical and aesthetic
Superficial Damage	Component has no visible permanent damage

### 2-2.2 Glazing Levels of Protection

The other portion of a building's level of protection is based on the damage expected by the window components. Level of protection ratings are based on glass fragment fly out and the potential to cause injury. Table 2-5 describes the hazards related to glazings along with potential injuries for building occupants for the various building level of protection.

There are multiple systems that are used to determine a hazard rating. Among these are ASTM F 1642, Department of State (DoS), General Services Administration (GSA), and the United Kingdom (UK) system. Different programs use different rating systems depending on the primary user group of the software. Since there are many different hazard rating systems that vary in allowable damage, equating hazard rating to LOP is the best way to compare multiple systems and ensure the proper level of protection is provided. Table 2-6 shows a comparison of the various rating systems available and how they compare to the level of protection descriptions in Table 2-5.



Table 2-5 Description of Glazing and Hazards

<b>Building Level of Protection</b>	<b>Potential Glazing Hazards<sup>2</sup></b>	<b>Potential Injury</b>
Below AT Standards <sup>1</sup>	Glazing will fail catastrophically and result in lethal hazards. (High hazard rating)	Majority of personnel in collapse region suffer fatalities. Fatalities in areas outside of collapsed area likely.
Very Low	Glazing will fracture, come out of the frame, and is likely to be propelled into the building, with the potential to cause serious injuries. (Low hazard rating).	Majority of personnel in damaged area suffer serious injuries with a potential for fatalities. Personnel in areas outside damaged area will experience minor to moderate injuries.
Low	Glazing will fracture, potentially come out of the frame, but at a reduced velocity, does not present a significant injury hazard. (Very low hazard rating)	Majority of personnel in damaged area suffer minor to moderate injuries with the potential for a few serious injuries, but fatalities are unlikely. Personnel in areas outside damaged areas will potentially experience minor to moderate injuries.
Medium	Glazing will fracture, remain in the frame and results in a minimal hazard consisting of glass dust and slivers. (Minimal hazard rating)	Personnel in damaged area potentially suffer minor to moderate injuries, but fatalities are unlikely. Personnel in areas outside damaged areas will potentially experience superficial injuries.
High	Glazing will not break. (No Hazard)	Only superficial injuries are likely.

1 - This is not a level of protection, and should never be a design goal. It only defines a realm of more severe structural response, and may provide useful information in some cases.

2 - Glazing hazard ratings are from ASTM F 1642.

Table 2-6 Level of Protection Comparisons

<b>LOP</b>	<b>UK (Old)</b>	<b>GSA</b>	<b>DoS</b>	<b>ASTM F 1642 (DoD)</b>
Below AT Standards	High Hazard	5	5	High Hazard
Very Low	Low Hazard	4 or 3b	4	Low Hazard
Low	Minimal Hazard	3a	3	Very Low Hazard
Medium	Minimal Hazard	2	2	Minimal Hazard or No Hazard
High	No Break	1	1	No Break

**This Page Intentionally Left Blank**

## CHAPTER 3 GLAZING PRODUCTS AND CONSTRUCTIONS

### 3-1 GLAZING CONSTRUCTIONS

This section covers typical glazing layups which are commonly used for architectural fenestrations.

#### 3-1.1 Monolithic Glass

The majority of glass used today in architectural applications is monolithic float or flat glass. It is the basic form of manufactured glass and there are minimal processes performed on the glass after it is manufactured. Monolithic glass may consist of annealed, fully tempered, heat strengthened, chemically strengthened glass. Monolithic glass is not preferred for blast applications because it creates a large quantity of flying hazardous debris due to the fact that there is nothing to retain the glazing fragments upon failure.

#### 3-1.2 Laminated Glass

Laminated glass consists of two or more layers of glass bonded together using an interlayer, usually polyvinyl-butylal (PVB) which is discussed later in Section 0. A typical example of laminated glass is the windshield of a car. Other interlayers are becoming more readily available, such as ionoplast interlayers. Ionoplast interlayers are typically more rigid and tear resistant than PVB. Laminated glass is preferred for blast applications due to the post break membrane capacity provided by the interlayer. This allows for more energy absorption than a monolithic pane of glass and also greatly reduces the flying debris.

#### 3-1.3 Insulating Glass Units

An insulating glass unit (IGU) consists of separate panes of glazing separated by a hermetically sealed airspace of constant thickness (typically 0.5 in.) which increases the window's thermal performance. Some IGU's are filled with an inert gas, such as krypton or argon, in place of air to reduce the chance of impurities staining the glass over time. The separate panes of glass can be constructed of monolithic or laminated glass using any of the glass types previously defined.

For blast applications, the inner pane (pane located toward the inside of a facility) must not generate hazardous debris such as fragments from laminated glass or broken polycarbonate. This is a basic requirement for the LOPs considered by UFC 4-010-01, but would also apply to higher levels of protection required by other criteria.

#### 3-1.4 Composites

Composites, such as glass-clad polycarbonates are generally manufactured for ballistic, impact, or forced entry resistant applications. They consist of combinations of various layers of glass and plastics, typically polycarbonate, laminated together with PVB and/or

urethane resin interlayers. These composites can have significant blast resistance, but must have adequate frame support to be effective.

### **3-1.5 Glass Block**

Glass blocks are manufactured solid or hollow blocks of glass which traditionally have been used as masonry units and laid up with mortar joints. Hollow blocks are made by sealing together two pan shaped glass castings into a hollow glass faced unit. Solid blocks are typically cast monolithically. When used in glass unit masonry construction, UFC 4-010-01 does not require glass block to comply with the Standard 10 provisions. However, engineered glass block window systems shall be designed in accordance with the Standard 10 provisions.

## **3-2 GLAZING PRODUCTS**

This section covers typical glazing products which are commonly used in architectural fenestration layups.

### **3-2.1 Annealed Glass**

The most common window glass available is referred to as annealed float glass or simply annealed glass. Since annealed glass has a minimal amount of residual internal stress it is subject to easy breakage but can be cut or edge shaped at anytime. Annealed glass is the most fragile of all manufactured glass. When fractured, annealed glass breaks into many small and large irregular-shaped sharp pieces called glass fragments or shards. The strength of annealed glass can vary significantly due to surface flaws. Hence, glass strengths are typically modeled with a probability distribution.

The history of research in first crack behavior of glazing has involved significant static testing of small glass coupons and glass panels. The onset of cracking occurs at the surface of the glazing and this crack is initiated from critical surface flaws, the locations of which are random. These surface flaws can occur as a part of the manufacturing process, during the installation process or due to in service weathering, abuse, etc. Older glazings are subject to longer term abrasion and weathering, which causes them to be weaker but also less variable in strength.

### **3-2.2 Heat Strengthened and Fully Tempered Glass**

Heat treating annealed glass can be done to produce two additional monolithic glass types: heat strengthened and fully tempered glass. To form either, fabricators cut annealed glass into its final size before the heat treating process. The pre-cut annealed glass pane is then heated to near its softening point, after which it is quenched. Quenching cools the outer surfaces quickly, while the inside of the lite cools more slowly. This differential cooling induces compressive stresses in the outer glass fibers and tensile stresses in the interior, the magnitude of which depends upon the quenching

rate. Figure 3-1 below illustrates the stress condition of a typical fully tempered glass lite.

Figure 3-1 Stress Distribution of Fully Tempered Glass

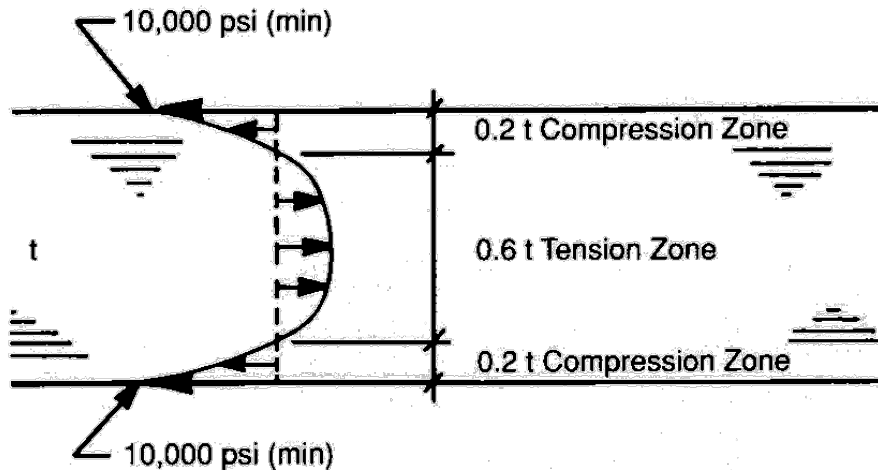

Heat strengthened and fully tempered glasses have nominal load resistances for design purposes of 2 and 4 times, respectively, that of annealed glass. Fully tempered glass breaks into much smaller, more cubical pieces than similar thickness annealed glass due to the stress distribution in the glass. This is the reason tempered glass is often referred to as “safety glass.”

### 3-2.3 Plastic Glazing

#### 3-2.3.1 Monolithic and Laminated Polycarbonate

Thermoplastic polymers can be used as impact, blast and ballistic resistant glazing as monolithic lites, laminated lites or in conjunction with glass. Combinations of glass and polycarbonates are often used as ballistic resistant glazing and are referred to as glass-clad polycarbonates. Glazing may also be produced in multiple layers of plastic laminated together, with or without glass laminations. These “stacked” systems may be used as blast resistant systems. The analysis codes described later in this report can be used to generate resistance functions suitable for determination of dynamic capacities of these systems. Optical clarity may be reduced in these systems due to the effects of both the thermoplastics and the laminating interlayers. The expected service life of hard-coated polycarbonate without glass cladding is approximately 25 years and is usually based on degraded optical clarity due to UV radiation and abrasion from exposure to the elements and cleaning.

### 3-2.3.2 Acrylics

Acrylic is also a thermoplastic polymer. It is often selected for glazing applications because of its higher optical quality (slightly better refractive index than glass, superior refractive index and luminous transmittance as compared to polycarbonate) and because of its lighter weight as compared to glass. Acrylics have approximately the same tensile strength and modulus as polycarbonates but have dramatically lower values of tensile elongation (polycarbonate elongation at break is approximately 150% while acrylics fail at elongations of approximately 30%). Because of the reduced ductility of acrylics, they are not as good of a choice for impact or blast resistant applications as are polycarbonates. Acrylics, like polycarbonates, can be machined for unique geometrical requirements, are often used as a replacement for heavy glass blocks and can also generate toxic gases in fires.

### 3-2.4 PVB Interlayers for Laminated Glass

Polyvinyl butyral (PVB) sheet, made from PVB resin, is the most common material used to fabricate laminated glass. Bonding of glass layers with PVB is accomplished by compressing the layers of glass tightly together with the PVB sheet in between. This “sandwich” is then heated until the PVB reaches its melting point, forming a high strength bond between the two layers of glass. The PVB layer (also referred to as the interlayer) commonly comes in thicknesses of 0.015”, 0.030”, 0.060” and 0.090”. For blast resistance, a thickness of 0.030” or greater is required by UFC 4-010-01. Laminated glass, whether used as a single pane or as the inner pane of an insulating glass unit, is the preferred glass construction for providing protection from the pressure effects of a bomb blast.

Laminated glass can fracture (and is usually designed to do so) under the blast load but the interlayer holds the broken glass together thus eliminating the spread of glass fragments to the interior. If designed properly, the fractured laminated glass will remain in the window frame and not open the building to the effects from the outside environment. Therefore, the strength of the glass used in the laminated construction is of secondary importance since the PVB interlayer is the element used to keep the fractured window pane in the window frame.

Typical static properties of PVB sheet resin interlayers are:

Tensile strength	3,500 psi
Tensile elongation	200%
Youngs modulus	50,000 psi

### 3-2.5 Specialty Interlayers for Laminated Glass

Ionoplast interlayers are quickly gaining popularity in both the hurricane- and blast-resistant communities. These interlayers can be up to 100 times stiffer than a typical PVB interlayer. This leads to a more robust piece of laminated glass which can take larger loads and greater impacts. This also means the deflections are reduced, which

can increase the load transmitted into the frames as it would likely produce a higher instantaneous shear load compared to the lower but longer duration tensile loads of PVB going through its large deflections.

Laminated glass products can also be produced with other specialty resins. Laminate products produced with cast-in-place (CIP) resins eliminate the flat plate compression and heating process of PVB lamination. CIP resin laminating is accomplished by pumping the liquid resin into the space between the glass and allowing it to cure (chemical curing) or curing it with UV light. CIP resins bond both chemically and physically to glass lites and even will bond with uneven (wavy) surfaces. These resins also produce stiff glazings which must be considered in the design.

### 3-2.6 Glazing Supported by a Frame

Regardless of which glazing type is being used, the lite has to be supported by the window frame. That support is provided by sufficient engagement or bite of the glazing in a frame pocket, and a bead of sealant material. Potential sealant materials may be a dry glazing gasket, adhesive glazing tape, or structural silicone adhesive. In dry glazing, bite is sometimes considered the total engagement length, or overlap, of the glazing into the frame. However, for the purposes of this PDC-TR, bite shall be considered the effective contact dimension of a structural sealant between the glazing and frame member. As an example, a lite could be overlapped 1 inch within a frame and have a ½ inch bead of structural silicone for the attachment, thus the actual bite would be considered to be ½ inch. Figure 3-2 depicts graphically the definition of bite and other important frame features.

Figure 3-2 Channel and Captured glazing

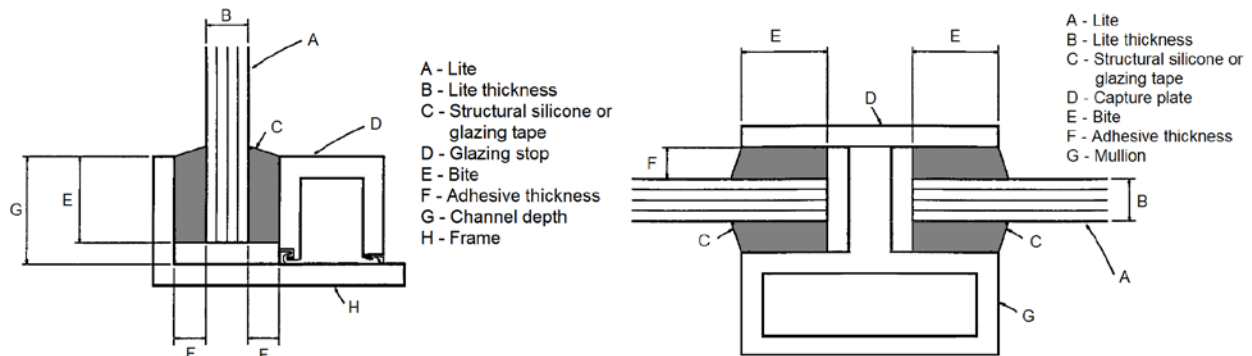

### 3-3 GLAZING STRENGTH AND GLASS PROBABILITY OF FAILURE

Since glass is a brittle material whose failure strength can be variable among identical lites, the strength of glass is modeled using statistical methods, specifically a probability distribution. This means that glass is designed primarily on historical experience and engineering judgment. The probability distribution utilizes a bell curve to plot break

strengths of lites of glass. Surface flaws and microscopic imperfections within the glass cause the variations in strength among identical lites of glass.

From the bell curve a probability of failure value can be determined, ranging from 1-999. This value is a fraction of glass lites that would break at the first occurrence of a specified design load, expressed in lites per 1,000. The most common design probability of failure used in conventional window designs is 8 lites per 1,000. For dynamic design this value can be increased due to rate effects and the likelihood of a blast threat occurring, but shall not exceed 500 lites per 1,000 as that may be overestimating the strength of the glass. Essentially that would limit designs to the 50th percentile. As the probability of failure increases, so does the assumed glass strength (e.g. Use of a high POF for a given design means that the glass is assumed to have a higher resistance and deformation capacity than is typically found in samples of that glass type and age).

### **3-4 BLAST RESISTANT GLAZING CONSIDERATIONS**

When using laminated glazing, framing systems need to have sufficient weep holes within the frame's glass pocket to allow moisture drainage. If laminated glass edges are in contact with water for extended amounts of time the lite can delaminate (i.e. the glazing layers begin to separate from the interlayer). This causes visual clarity issues in the lite as it looks like there are air bubbles within the glazing. In addition contact with incompatible glazing compounds can cause deterioration of PVB and delamination of the pane, it is therefore important that either glazing tape or structural silicone glazing be specified for mounting laminated windows.

In some instances a window system will need to use a stronger, heat strengthened glass in a laminated window system. In these systems the thickness of interlayer can be critical. During the heat treating process, the glass develops roller waves in the surface of the glass as it passes over the rollers while it is quenched. If the thickness of the interlayer is insufficient to adequately fill the gaps between the wave "peaks", this could create weakness within the lamination. Typically, the laminator will require the use of a thicker interlayer material to accommodate these waves. It is best to discuss these issues with the window laminator.

When polycarbonate is used in a window system, there are some considerations which must be addressed to ensure a quality system is provided. Among these considerations is ensuring the appropriate amount of bite in the frames since polycarbonate systems are not typically installed using a wet glazed system. Additionally, a glass cladding or some type of hard coating should be applied to ensure that the surfaces of the polycarbonate are protected from being scratched and marred during typical usage.

### **3-5 TYPICAL MAKEUPS AND SYSTEMS**

This section covers typical fenestrations which are commonly used in typical construction.



### 3-5.1 Punched Windows

Punched windows are individual windows that appear to have been “punched” through the otherwise continuous wall system around it. The façade material is on all four sides of the window. An illustration and an example of punched windows are shown in Figure 3-3 below.

Figure 3-3 Punched Windows

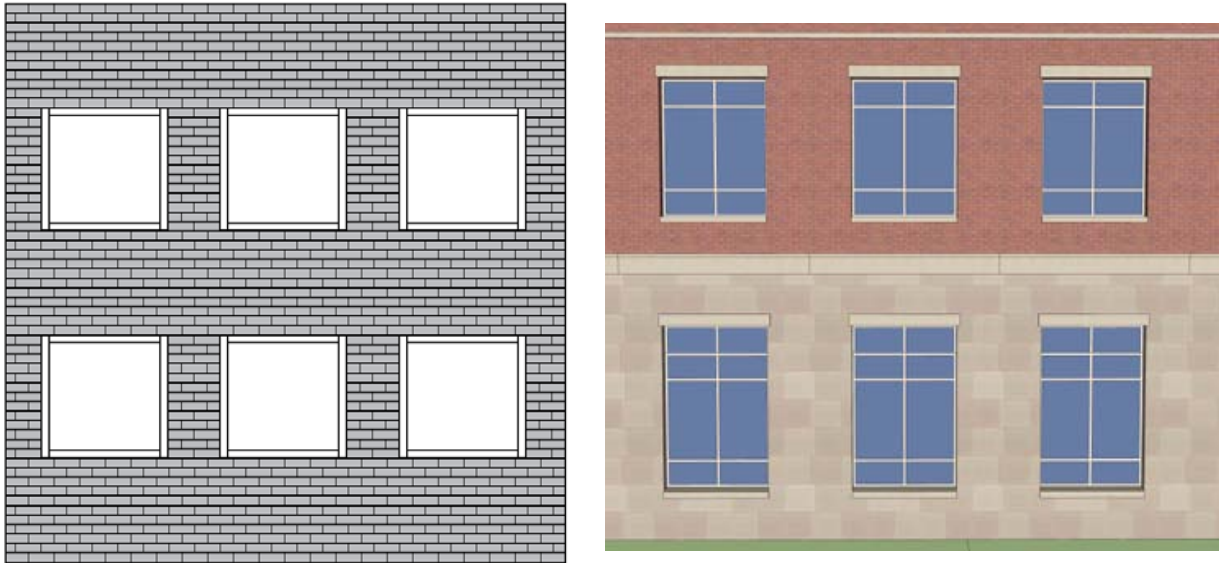

Punched windows are one the most common window systems currently being used in construction. The opening is typically framed with jamb elements, which support the vertical edge of the window. The wall space above and below usually does not provide any lateral support for the window, and it is typically assumed that all of the load is transferred to the vertical jambs.

### 3-5.2 Ribbon Windows

Ribbon windows are essentially a string of windows placed edge to edge forming a horizontal band. They can be installed with or without exposed mullions and appear to form a “ribbon” around the exterior of the building. An illustration and example of ribbon windows are shown in Figure 3-4. Ribbon windows are generally connected to the head and sill. Loads are typically transferred through the head and sill members directly to the columns or by cantilever action of sill and head stem walls.

Figure 3-4 Ribbon Windows

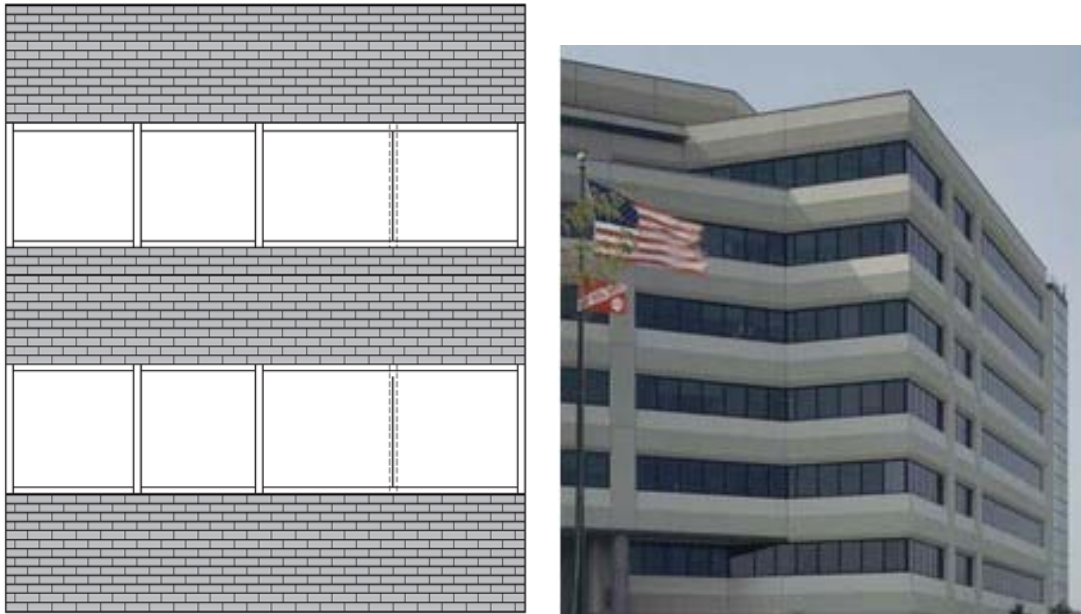

### 3-5.3 Storefronts

Storefronts are a non-residential system of doors and windows mullioned, or combined, as a composite structure consisting of larger expanses of glazing. They are typically designed for high use/abuse and strength. The storefront system is non-load bearing and is typically installed between the floor and header or is set back from the exterior wall and provided with a ceiling and sidewalls to close the space between the storefront and wall. The ceilings and sidewalls in some cases provide lateral support to the storefront system and may also need to be designed for blast. An illustration and an example of a storefront system are shown in Figure 3-5.

Figure 3-5 Storefront System



For the purposes of storefronts and curtain walls, primary mullions are those that span between points of structural support and are typically vertical. Intermediate mullions are those which frame between the primary mullions and are typically horizontal. There are many different variations of storefront designs, which mean the vertical mullions are not always the primary mullions.

### 3-5.4 Curtain-Walls

Curtain walls are external non-load bearing walls which are intended to separate the exterior and interior environments. Curtain walls can use a variety of materials ranging from precast concrete to glass. Typically, curtain walls span multiple floors and are considered part of the building envelope. An illustration and example of a curtain wall are shown in Figure 3-6 below.

Figure 3-6 Curtain Wall Windows

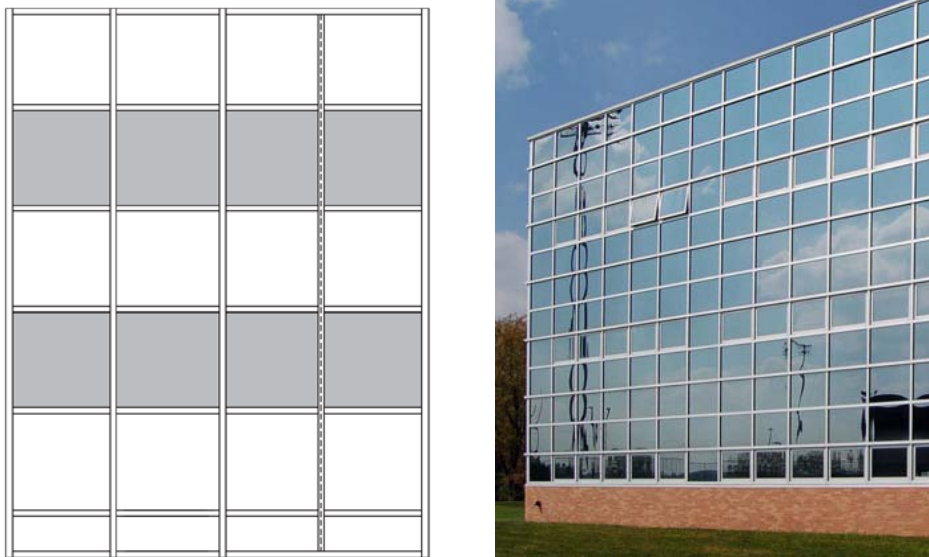

Just as for storefronts, primary mullions are those that span between points of structural support and are typically vertical. Intermediate mullions are those which frame between the primary mullions and are typically horizontal. There are many different variations of curtain walls, so the vertical mullions are not always the primary mullions.

### 3-5.5 Butt-Joint Glazing Systems

Butt-joint glazing systems consist of multiple lites supported on two edges (typically top and bottom) in conventional (captured) window frames or wet glazed frame systems while the remaining two edges (vertical edges) are “butted” together and weather sealed with a bead of silicone sealant. Since there is no vertical framing member supporting the vertical edges, the butt-joint cannot be considered to be structural. Being supported on two edges, the glass is considered to span in only one direction thus leading to higher deflections and stress than a four-side supported system. Butt-joint glazing can typically be seen in ribbon or curtain wall systems.

### **3-5.6 Structural Silicone Glazing Systems**

Structural silicone glazing systems are similar in exterior appearance to butt-joint glazing, but structural silicone glazing has a mullion to support the butted edges on the interior of the system. These systems utilize structural silicone as an adhesive to affix the glass to the framing system. The glass may or may not be retained on the exterior side in a typical captured manner. Structural silicone glazing is usually supported on all four sides but may be captured on the exterior side on two or more sides.

### **3-5.7 Glazing in Doors**

Doors which contain glazing are analyzed similarly to glazing used in a typical wall application. Glazing can be used in swing doors, slider doors, and single or double leafed doors.

### **3-5.8 Operable Window Systems**

Operable windows such as sliders, hoppers, or casement type windows which opens outward are treated as fixed windows since it is assumed that they will seat themselves against the window frame in a blast event. Windows which open inward must have the operable and locking hardware analyzed to resist the blast load as to prevent the whole window leaf from dislodging and becoming a hazardous projectile.

### **3-5.9 Non-Traditional Systems**

It is not possible to cover all types of window systems and anchorage options. Manufacturers are constantly researching and releasing new options for blast protection. It is up to the engineer to determine the loads, behavior and adequacy of the system. Alternately these types of systems can be tested dynamically to demonstrate their capacity.

## **3-6 WINDOWS DESIGNED TO RESIST ENVIRONMENTAL LOADINGS**

Windows may be required to provide protection from more than one hazard. For example, in coastal regions where hurricane resistant glazing is required, there may also be a requirement for blast resistant windows. Each design has its own unique requirements in order to be successful. An approach to design for a dual purpose would be to design the window to the more stringent requirement, most likely the hurricane requirements, and then verify that design to ensure it is adequate for the required blast loading and complies with all blast criteria. Analysis of windows for impact is not included in this PDC-TR; the designer must consult the appropriate codes and criteria for applicable requirements.

## CHAPTER 4 DESIGN APPROACHES

### 4-1 GENERAL

This chapter covers two design approaches, a static and dynamic approach. The static approach uses simplified assumptions to model dynamic loadings and the response of window components. Due to these assumptions, there tends to be conservatism within the analyses. The dynamic approach models a component's response based on the actual dynamic loading due to a blast event. Also, the analysis takes into account dynamic material properties and the allowable dynamic response of the component. Often a statically designed system will be overly conservative in comparison to a dynamically designed system. Dynamic analysis is preferred because it typically yields a more economical design.

### 4-2 STATIC DESIGN APPROACH

For windows and skylights using laminated glass glazing, the static design approach is allowed for the design of the glass, frame, bite, and connections. The design of supporting structural elements may be done statically for window and skylight systems of any glazing material, only when the wall conventional construction standoff distance or greater is provided.

Using the static design approach, the laminated glass, frame, bite, and connections are designed according to ASTM F 2248-09 and ASTM E 1300-09a practices. ASTM F 2248-09 is used to determine an equivalent 3-second duration design load, which is used in conjunction with ASTM E 1300-09a to select an appropriate glass type and thickness.

All static designs for window frames and their connections to the structure and supporting structural elements and their connections should be performed using LRFD with load factors equal to 1.0. Strength reduction factors ( $\phi$ ) shall be 1.0 for window frame and supporting structural member designs. Strength reduction factors ( $\phi$ ) shall be taken from the appropriate material code for all connection design.

$$R_u \leq \phi R_n$$

Where:

$R_u$  = required strength

$R_n$  = nominal strength

$\phi$  = resistance or strength reduction factor

#### **4-2.1 Alternate Glazing**

Glazing other than laminated glass cannot be designed statically since there are currently no national consensus standards available for the static design of alternate glazing. Alternate glazings must be designed or tested dynamically to demonstrate the appropriate level of protection.

#### **4-2.2 Applicable Levels of Protection**

The static design approach is applicable only for the low and very low LOPs. For a medium or high LOP, window systems must be designed dynamically because the dynamic analysis assures a more accurate modeling of the windows response.

#### **4-2.3 Applicable Charge Weights**

The static design approach is only applicable for the range of explosive weights and standoff distances covered in ASTM F 2248-09. Do not extrapolate beyond the limits shown in Figure 4-1.

#### **4-2.4 Non-Reflected Pressures**

The static design approach is predicated on fully reflected blast loadings of windows, but it can be used for cases other than reflected pressures such as incident pressures that would typically be used for horizontal skylights. The usage of this approach for other than fully reflected blast loadings would likely produce conservative results. To avoid overly conservative designs, use a dynamic design approach that accounts for the angle of incidence of the blast.

#### **4-2.5 Glazing**

Laminated glass thickness is determined using ASTM E 1300 in conjunction with ASTM F 2248-09. Glass can be annealed, heat strengthened or fully tempered. This procedure determines a glass thickness based upon first break of the glass and does not consider post break resistance of the PVB interlayer, thus the resulting glass thickness produces a minimal hazard rating per ASTM F 1642.

Additionally, thicker PVB layers typically do not alter the glazing resistance as it is calculated based on the combined thicknesses of glass and interlayer plies. The only time it would affect the glazing resistance would be the case where a thick PVB layer drives the combined thickness to the next higher monolithic thickness.

##### **4-2.5.1 Determine Equivalent 3-Second Design Load**

The first step is to identify the explosive weight and a standoff distance for the design. Using the explosive weight and standoff distance pair, an equivalent 3-second duration design load is determined from ASTM F 2248-09.

To determine the equivalent 3-second duration design load, enter the chart in ASTM F 2248-09, see Figure 4-1, with the standoff distance on the X axis. Draw a vertical line from the standoff distance. Then draw a horizontal line from the intersection of the vertical line and the diagonal charge weight lines to the Y axis. The equivalent 3-Second duration design load is the value where the horizontal line intersects the Y axis. The load in pounds per square foot (psf) can be read from the left Y axis or in kilopascals (kPa) from the right Y-axis.

Interpolate between charge weight lines as necessary. If a threat is beyond the limits of the figure, extrapolation is not permitted and either testing or a dynamic analysis would be required for the window.

It is important to note that the equivalent 3-second duration design load *is not* a “static equivalent” of the blast load generated by a given explosive weight and standoff distance. Rather it is a uniform lateral load of short duration which when used with ASTM E 1300-09a, yields a glass thickness that would be capable of resisting the lateral pressures of the actual dynamic load for a specified probability of breakage.

Figure 4-1 ASTM F 2248-09 Chart Used to Determine the 3-Second Load

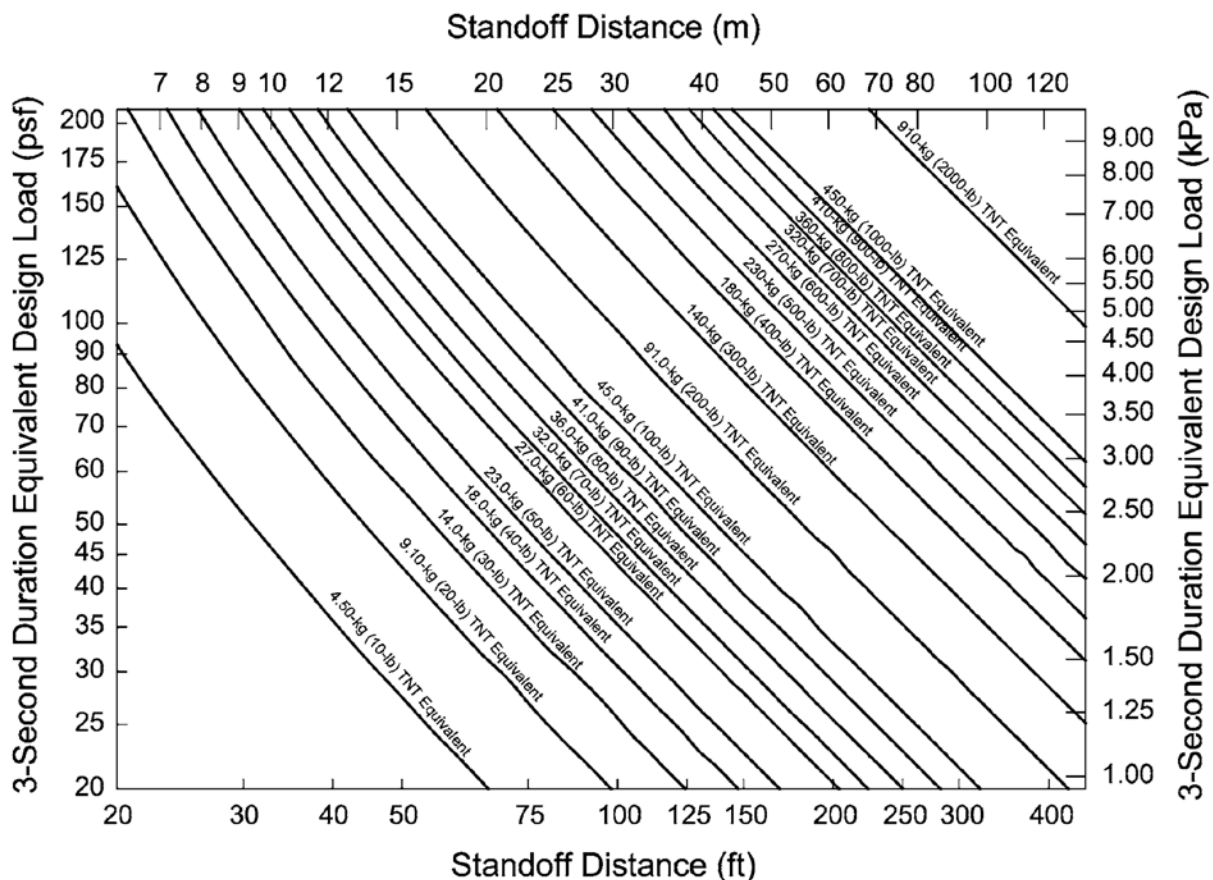

Adapted, with permission, from ASTM Standard ASTM F2248-09, Standard Practice for Specifying an Equivalent 3-Second Duration Design Loading for Blast Resistant Glazing Fabricated with Laminated Glass, copyright ASTM International, 100 Barr Harbor Drive, West Conshohocken, PA 19428. A copy of the complete standard may be obtained from ASTM International, [www.astm.org](http://www.astm.org).)

#### 4-2.5.2 Determine Laminated Glass Thickness

Using the 3-second load, the glazing layout may be determined using ASTM E 1300-09a. Select a glass type, thickness, and construction and then use the appropriate procedure in section 6 of ASTM E 1300-09a. All procedures follow the same general process; determine a non-factored load (NFL), glass type factor (GTF), and load share factor (LS). Single lite glazing will have one value of each factor. Multi-lite glazing, will have a value of each factor for each lite. The glass load resistance (LR) is then found by multiplying all of the values together for each representative lite. The LR for multi-lite units is the lowest of the calculated values. The process is iterative and must be repeated if the LR is less than the 3-second load. Any or all of the glass type, thickness or construction should be modified until the LR is greater than the 3-second load.

For low and very low LOP window systems, use the thickness determined from ASTM E 1300-09a including the interlayer thickness assumed, but not less than a minimum 0.030-inch thick interlayer. For medium and high level of protection the static design approach is not allowed.

#### 4-2.6 Frame Members

For static design of aluminum and steel frames, follow ASTM F 2248-09. Frames made of other materials are acceptable but their performance must be established with dynamic analysis or testing; ASTM F 2248-09 is not applicable.

The deflections limit for frame members designed statically is 1/60 of the length of the glazing supported edge, regardless of anchor spacing, when subjected to a load of two (2) times the glazing resistance determined from ASTM E 1300-09a. The member should be checked based on section properties determined from the design strength calculations under loading of two (2) times the glazing resistance at yield strength of the frame material.

For punched and ribbon windows, the length of the supported edge is the longest span of a single pane of glass, regardless of any intermediate support connections.

For storefront and curtain wall systems, the glazing supported edge length used in the deflection calculation is dependent on whether the frame member under consideration is a "primary" or "intermediate" mullion. For the purposes of this PDC TR, a "primary" mullion is a frame member which spans between points of structural support, e.g., floor to floor while an "intermediate" mullion is one which spans between primary mullions. The length of the glazing supported edge for primary mullions will be taken as the full span between points of structural support. The length of the glazing supported edge for intermediate mullions will be taken as the longest edge of a lite of glass, which is supported by that mullion. The supported edge lengths can be seen in Figure 4-2 and Figure 4-3. The deflections of both mullions are restricted to 1/60 of the supported edge length when subjected to two (2) times the glazing resistance applied over the tributary area of the glazing for the frame member in question.



Figure 4-2 Storefront Support Lengths

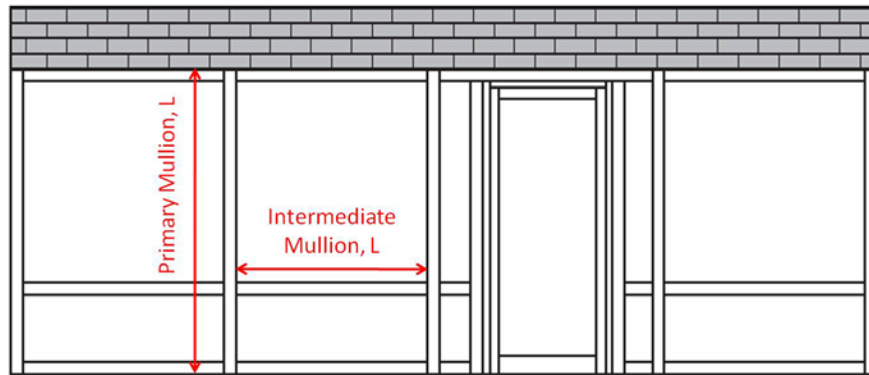
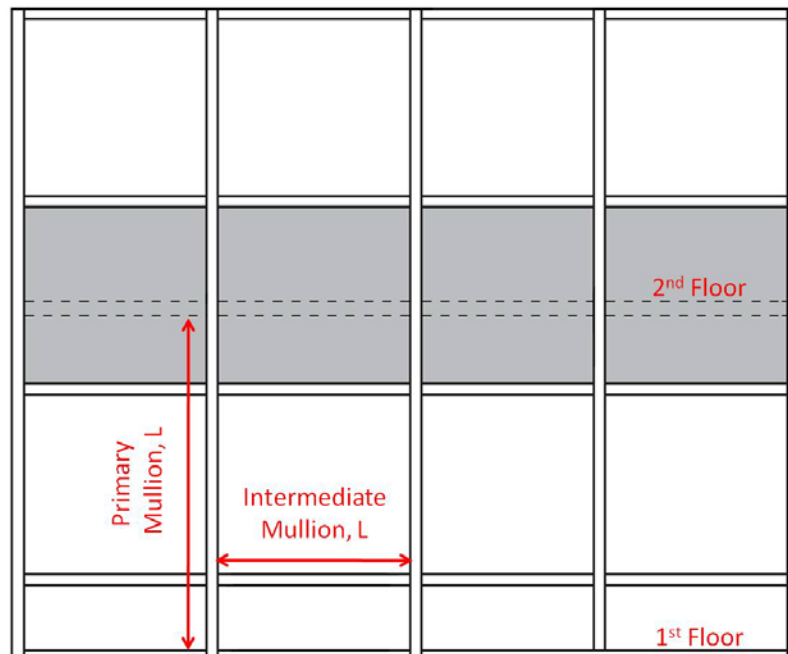

Figure 4-3 Curtain Wall Support Lengths



#### 4-2.7 Bite

Determine the required bite using ASTM F 2248-09. The ASTM allows either structural silicone sealant or adhesive glazing tape to adhere the glazing to the frame. Apply structural silicone or glazing tape on both sides of a single laminated lite. For IGUs, the structural silicone or glazing tape need only be applied to the inboard (protected) side. The inboard lite of the IGU must be a laminated lite.

The minimum width of the structural silicone bead shall be the larger of 3/8" or the thickness of the laminated pane. The structural silicone bead shall be no wider than twice the laminated pane thickness. The width of glazing tape shall be a minimum of

twice the laminated pane thickness but no wider than four times the laminated pane thickness. Static design of dry glazed systems based on ASTM F2248 is not permitted.

#### **4-2.8 Connections**

Static design of connections follows the provisions of ASTM F 2248-09. Connections include connection of frames to the surrounding structure, connection of hardware and associated connections, connection of glazing stop connections, and connection of other elements in shear.

##### **4-2.8.1 Connection Design Load**

The assumption in connection design using ASTM F 2248-09 is that the glazing will fail before the frame members and their connections. To ensure this, connections are designed to at least;

- Two (2) times the load resistance of the glazing determined from ASTM E 1300-09a if the maximum airblast pressure is greater than one half magnitude of the load resistance of the glazing;

OR

- One (1) times the load resistance of the glazing if the maximum airblast pressure is less than one half magnitude of the load resistance of the glazing.

The maximum airblast pressure is the peak reflected pressure during the blast loading.

Typically, the load for connection design will be two (2) times the load resistance of the glazing. This is due to maximum airblast pressures frequently being greater than the maximum resistance determined from ASTM E 1300-09a.

##### **4-2.8.2 Connection Design Strength**

Design strength ( $\phi R_n$ ) of a connection should be based on the applicable design codes for the connector and base material. The design shall take into account edge distance, spacing, embedment depth, material strength, etc. to fully develop the connectors. Strength reduction factors ( $\phi$ ) shall be taken from the appropriate material code for all connection design.

The design load is applied over the tributary area of the glazing supported by the frame members. The designer may choose to apply this load uniformly over the entire glazing area to determine a total number of fasteners to be provided around the anchored perimeter or may determine the number of anchors each frame member would require based on the glazing area tributary to the individual frame member.

## 4-2.9 Supporting Structural Elements

The static design approach for supporting structural elements may only be applied to punched openings, and is only allowed when the standoff distance provided to the window is at or greater than the wall conventional construction standoff distance. Dynamic analysis or dynamic testing is required when the standoff is less than the wall conventional construction standoff distance or when a ribbon window system is provided. Where the static approach is allowed, base the static design of the supporting element on the following.

### 4-2.9.1 Determination of Tributary Width Increase Factor

Account for an increased tributary area due to the addition of a window to a wall by applying a tributary area increase factor (C) to the capacity of the wall. The tributary area increase factor is shown in Equation 1 and shall not be taken as less than 1.0.

Equation 1 Tributary Area Increase Factor

$$C = \frac{a_{trib}}{a_{wall}} \geq 1$$

Where:

$a_{wall}$  = tributary area for typical conventional wall section or element

$a_{trib}$  = combined tributary area for supported window or skylight and wall or roof section or element

The tributary area of a typical structural element is the width of the element (e.g. spacing of the studs, reinforcement, or other structural member) multiplied by the height of that element. The tributary area of the supporting structural element is the width of element plus the width of the window that transfers load to that supporting structural element multiplied by the height of that element. Typically this width is half the window width plus half of the stud/reinforcement spacing. The dimensions used in the calculation are shown graphically in Figure 4-4 where the solid vertical lines are studs/reinforcement and the dashed lines are the tributary width lines.

Figure 4-4 Illustration of Tributary Width Values

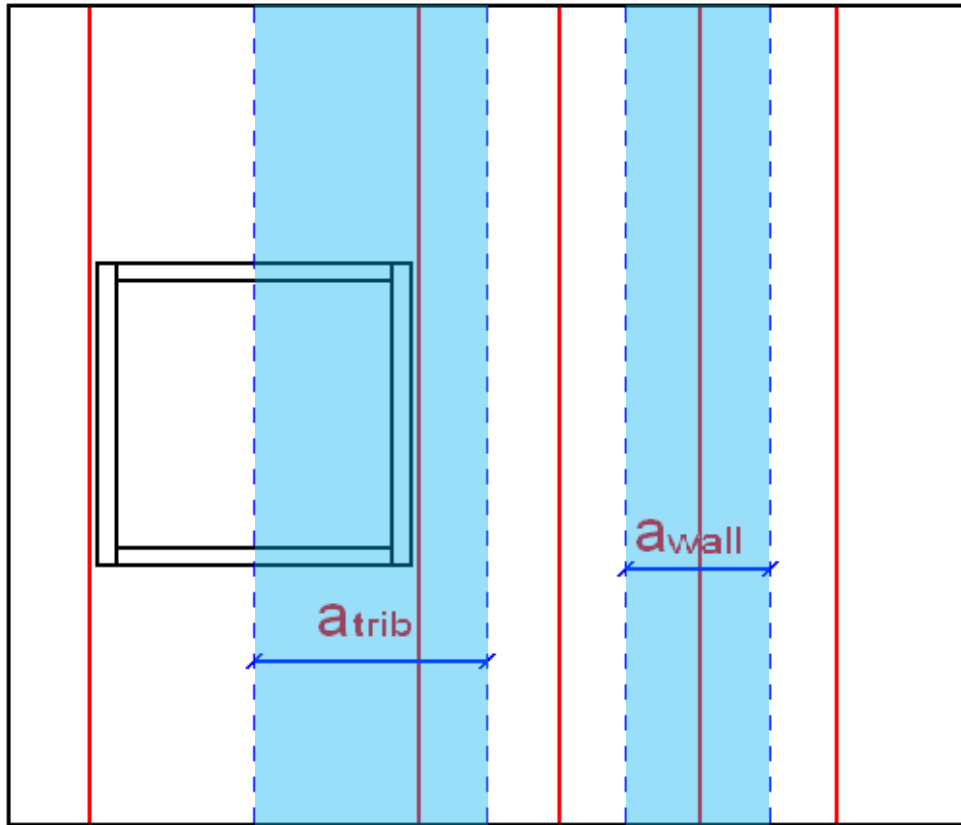

#### 4-2.9.2 Required Supporting Structural Element Capacities

Calculate the moment and shear capacities of the typical wall element. Design the supporting structural elements (SSE) to have moment and shear capacities equal to or greater than the typical wall element capacities multiplied by the applicable tributary area increase factor as shown in Equation 2 and Equation 3.

Equation 2 Required Moment Capacity of Supporting Structural Element

$$M_{SSE} \geq C \cdot M_{CW}$$

Equation 3 Required Shear Capacity of Supporting Structural Element

$$V_{SSE} \geq C \cdot V_{CW}$$

Where:

$M_{SSE}$  and  $V_{SSE}$  are moment and shear capacities of supporting structural element.

$M_{CW}$  and  $V_{CW}$  are moment and shear capacities of conventional wall section.

### **4-2.9.3 Supporting Structural Element Reactions**

Design loads for connections between the supporting structural element and the primary structure shall be determined based on the increased member shear capacity ( $V_{SSE}$ ). The structural designer is to design the connection using the appropriate strength reduction factors from the applicable design code.

The reactions from the supporting element analysis normally do not have to be carried through the horizontal and lateral bracing systems of the building to the foundation. The main concern is that these loads are transferred into horizontal floor and roof systems without failing those connections or the attached elements, as the building mass should be sufficient to dissipate these loads before they are transferred to the foundation. It is left to the structural engineer to assess the adequacy of these connections, the attaching elements, and the need for further analysis.

### **4-2.10 Skylights**

Skylights designed using the static approach shall follow the same procedure as outlined above.

## **4-3 DYNAMIC DESIGN APPROACH**

Dynamic design of window systems can provide more economical designs than those based on the static approach. The dynamic approach more accurately predicts component response than the static approach by accounting for the time variance of the blast load, dynamic material properties and dynamic response of the component. The dynamic approach can use most glazing types, not just the laminated glass allowed in the static approach. Most glazings, frame members, and supporting structural elements can be modeled using a dynamic approach.

Dynamic design uses computer programs recognized by the blast community to predict dynamic response. The dynamic approach is an iterative process of selecting a initial glazing or member size, then analyzing it and repeating until the glazing or member is found to have an acceptable response.

Only engineers having a thorough understanding of structural dynamics should use dynamic analysis software. Users should also educate themselves on how the software performs its analysis (i.e., methodology and assumptions used as well as hazard level definitions). This can be done by reading methodology manuals and help files that accompany the software. Using programs blindly without an understanding of the methodology and assumptions can result in erroneous results.

### **4-3.1 Alternate Glazings**

Dynamic design of glazing materials other than laminated glass requires defined material properties and models for the material. Most glazing design programs include a library of material types. It is good practice to verify the default material properties in

the program before proceeding with an analysis. Use non-default values only when a strong technical basis to do so exists.

#### **4-3.2 Applicable Levels of Protection**

The dynamic design approach is applicable for all levels of protection and the dynamic design approach and the methodology remains the same for all levels of protection. The response limits and hazard ratings are the key parameters that vary with level of protection. Each level of protection has an associated component response limit and glazing hazard rating, which reflect the acceptable amount of damage or hazard of that component or glazing when subjected to the blast loading. Response limits may vary with type of member, support conditions, material type, and various other parameters.

#### **4-3.3 Applicable Charge Weights and Blast Parameters**

The dynamic approach is an acceptable analysis method for glazing systems regardless of the threat severity since the design is based on the actual airblast loading the member will experience. Also, factors other than charge weight and standoff may modify the airblast loading. These are the inclusion of negative phase and clearing effects.

##### **4-3.3.1 Charge Weights**

When performing a dynamic design, the designer should use the dynamic blast load associated with the applicable explosive weight at the available standoff distance.

##### **4-3.3.2 Negative Phase**

Traditionally, analysis of component response to blast has only considered positive phase loading. An approach used by some engineers with experience in blast effects is to include the negative phase when analyzing blast damage to existing building components and to ignore the negative phase when designing new components. Negative phase has a more significant effect on the element response when the full duration of the negative phase occurs prior to the elements maximum response. Conversely, it has little or no effect when the positive phase loading duration exceeds the element maximum response time. For Medium and High Levels of Protection, negative phase shall be checked. For the purpose of design, whenever negative phase is accounted for in the analysis, an additional load case of positive phase only shall be performed to determine the worst case response of the positive and negative phase load and the positive phase only load.

##### **4-3.3.3 Clearing Effects**

Clearing effects occur due to pressure discontinuities at the edges of surfaces that develop when the blast wave impacts a surface. Higher pressures (reflected pressures) occur on the surface than exist a short distance off from the edge of the surface. The pressure discontinuity can result in quicker dissipation of the blast wave in higher-pressure areas. For windows away from building corners, the dissipation does not

occur soon enough to result in significant load reduction; hence, ignoring clearing is acceptable and results in a conservative analysis. For windows being analyzed near building corners and some skylights, accounting for clearing effects may result in a design that is more economical.

#### 4-3.4 Glazing

There are various programs available to analyze glazing dynamically, two of which are SBEDS-W and WinGARD. SBEDS-W is available from the Protective Design Center (PDC) and WinGARD is available from the Whole Building Design Guide (WBDG).

Typical input data includes window pane dimensions, height above the floor, glazing makeup, glazing properties, and blast load parameters. The window pane size should be taken as the clear span of the glazing in both directions. If the height above floor is not known, a reasonable assumption should be made.

Typically windows are supported uniformly on all four sides, but there are some instances where different support methods are used. One method would be butt-joint glazed systems where the top and bottom are supported and the vertical edges are glued together with silicone. Another glazing support method would be point supported systems, where the glazing pane is attached only at its corner points by the means of "spider" clips. Currently there are no SDOF tools available which can analyze point supported systems, so analysis would have to be by higher fidelity finite element analysis. Ultimately, it is up to the designer to determine how the glazing is supported and use the appropriate method of analysis.

Typical glazing properties are generally populated by the program when a glazing type is selected. In most cases, the default values will be acceptable, but if specific input data is used, it should come from a manufacturer, a testing lab, or other credible source. In some programs, user-defined glazing types may be generated, but the designer must ensure that all input properties are appropriate for the defined material. Again, these input properties should come from a credible source.

Use the default probability of failure (POF) value of the analysis program, but it shall not be greater than 500 per 1,000. By restricting the POF to 500 per 1,000 or less, it prevents the user from under predicting the glazing response by modeling an unusually strong piece of glass.

If the analysis indicates that the required hazard rating has not been met, the designer will need to revise various input parameters and perform another analysis. Designing a window to achieve a desired hazard rating is typically an iterative process.

When revisions need to be made to a glazing layup, it is not always necessary to thicken the glass. In some instances, it may be more beneficial to thicken the PVB interlayer. In order to provide a more economical window, which performs to the appropriate hazard rating, the designer will likely have to experiment by balancing

various input parameters such as window size, glass thickness, glass type, and PVB thickness.

#### 4-3.5 Frame Members

Frames that are designed dynamically may be analyzed using a single degree of freedom (SDOF) program such as SBEDS, which is available from the PDC. SBEDS-W also includes a mullion analysis tool that can model mullions consisting of standard structural shapes or extruded shapes with or without thermal breaks, and can account for composite and non-composite inserts. There are other programs available, but for the purposes of this PDC TR, SBEDS will be demonstrated. Additionally, finite element modeling (FEM) would be acceptable if performed by an experienced engineer using a recognized FEM program.

In most SDOF programs, required input data may include span length, spacing (tributary width), material properties, section properties, blast load parameters, and response criteria. Most manufacturers' window frame cross sections will not be available as a default selection within the programs' libraries. A user-defined section will typically need to be created using the frame's section properties.

The blast loading of the window frame members should be based upon the tributary area of the glazing supported by the frame member being analyzed. Additionally, for dynamic design, the member's span length may be taken as the distance between intermediate support connections when those intermediate support connections are directly anchored to or supported by the structure. Operable windows can be designed similarly to those with fixed frames provided they are constructed and installed so the sash will bear against the frame under blast loading.

##### 4-3.5.1 Frame Member Response Limits

For the purposes of this report, the response limits for aluminum and steel frame members shall be taken from Table 4-1. Response limits for steel frame members shall be in accordance with PDC TR 06-08 and ASCE 59-11.

Table 4-1 Mullion Response Limits

Mullion Material	Level of Protection							
	High		Medium		Low		Very Low	
	$\mu_{max}$	$\theta_{max}$	$\mu_{max}$	$\theta_{max}$	$\mu_{max}$	$\theta_{max}$	$\mu_{max}$	$\theta_{max}$
Aluminum	1	-	5	3°	7	6°	10	10°
Steel	1	-	-	3°	-	6°	-	10°



#### 4-3.6 Bite and Engagement

When glass is designed dynamically using SBEDS-W and WinGARD, one of the output values is the required bite. This is usually based on a shortening or pullout calculation due to the deflection of the glazing. When the glazing deflects inward, the edges are drawn towards the center of the window causing a shortening of the plan dimensions of the pane. If this shortening is too great, the window could disengage from the frame. The required bite is a calculated value that provides sufficient engagement of the glazing in a non-adhered system. Using this value is conservative, since structural silicone adhesive or glazing tape within the bite is normally provided. Therefore the bite required by computer analysis shall be provided at Medium and High LOP. Alternately, for low and very low LOPs, the required bite can be determined using the requirements found in ASTM F 2248-09.

#### 4-3.7 Frame Connections to Supporting Structural Elements

Connections designed dynamically are based on equivalent static reaction loads from a glazing analysis or from the reactions of a frame analysis. Using glazing analysis typically results in more conservative design due to designed for the ultimate resistance of the glazing and the assumptions which go into the calculations. Frame analysis loads tend to be more accurate since they are based on the actual blast loading that is acting on the frame, but it can be difficult to get the proper design load out of the results of these analyses.

Generally, the connection design loads are taken as the equivalent static reactions from a dynamic blast loading. Take fastener design strengths ( $\phi R_n$ ) from manufacturers' data. The number of connectors is calculated according to the applicable LRFD design code being used and the reduced nominal strength of the connector using all appropriate strength reductions factors ( $\phi$ ). Connectors around the window frame typically start about six inches from the corners and are spaced evenly between those points.

#### 4-3.8 Supporting Structural Elements

Generally, structural wall elements are designed as being part of the field of the wall. The addition of an opening usually increases the tributary area of the supporting components, which results in increased load transfer to the supporting structural elements around that opening. The additional load must be taken into account in the analysis. Often the portion of the wall above and below the window is non structural and is generally not considered to aid in resisting the blast load.

Do not use a dynamic reaction load history output from a glazing analysis as a blast load input type when analyzing supporting structural elements. These dynamic reaction loads are only applicable for blast load input types in frame design since the frame

directly supports the glazing. Therefore they are not applicable for blast load input types in supporting structural element design.

Analyze supporting structural elements for the explosive weight, standoff distance, and to the required LOP. The LOP determines the response limits for the specific component. Response limits are presented in PDC TR-06-08. If the response of the structural elements is unacceptable, the analysis must be redone with structural elements that provide the required stiffness and flexural resistance to meet the response limits and also provide the required shear capacity. Using a dynamic analysis to design the supporting structural elements will usually provide a more economical design and higher level of accuracy than the simplified method used in static method.

#### **4-3.8.1 Supporting Structural Element Connections**

Connections of supporting structural elements to the structure are designed dynamically based on the equivalent static reaction of that member subjected to a specific blast load. Take fastener design strengths ( $\phi R_n$ ) from manufacturers' data. The number of connectors is calculated according to the LRFD design code being used and the reduced nominal strength of the connector using all appropriate strength reduction factors ( $\phi$ ). Connections should account for all potential failure modes for the given connection type and base material being connected to.

When designing members to remain elastic, i.e. High Level of Protection, a load factor of 1.5 should be applied to the equivalent static reaction, but not larger than the maximum resistance force that member can transfer. This is to ensure that the connection remains elastic and does not fail before the member can fully respond. At lower levels of protection this is not required since the structure is allowed to be damaged.

#### **4-3.9 Skylights**

Skylights designed using the dynamic approach shall follow the same procedure as outlined above with the following adjustments.

The dynamic blast load that is applied to the skylight in most cases will be an incident load to account for the slope of the skylight. Additionally, the standoff distance can be increased by means of straight line measures from the explosive device to the skylight. Just as the static design approach is restricted to a medium LOP for skylights, so shall the dynamic design procedure. This means the glazing will have a minimal hazard as defined in ASTM F 1642. Designing to a medium LOP is required due to increased glazing fragment hazards when debris falls from the elevation of skylights. Therefore, skylight glazing may be designed to break, but must remain in the frame.

## GLOSSARY

### *ACRYLIC*

Acrylic is a plastic or Plexiglas® material often used for window glazing.

### *AIRSPACE*

The measured distance between the inner surfaces of the two pieces of glass in an insulated unit. Also used in reference to the thickness of the spacer bar.

### *ANNEALED GLASS (AN)*

This is the most common glass type that is used in construction. It is also the weakest glass type and fails in large hazardous dagger-like fragments.

### *BITE*

The effective structural contact dimension of a structural sealant

### *CHARGE WEIGHT*

See Explosive Weight

### *CHANNEL GLAZING*

The installation of glass products into U-shaped glazing channels which may have fixed glazing stops. At least one glazing stop on one edge must be removable.

### *COMMERCIAL WINDOW*

A window used in commercial buildings, which are normally heavier than residential windows and often anodized.

### *CURTAIN WALL*

An external nonbearing wall, intended to separate the exterior and interior spaces.

### *DRY GLAZING*

Glass or plastic lites, constructions or insulated glass units (IGU) that are held in a frame system with glazing tape, gaskets or other non-structural materials.

### *EXPLOSIVE WEIGHT*

The equivalent weight of TNT used to describe an explosive threat. Charge weight is another term used.

### *EXTRUSION*

A component produced by forcing a material through a die to form a part that has a cross section similar to the opening in the die. In the window industry, the resulting part obtained from the extrusion process makes up the structural members of a window or door. This part is usually aluminum or a vinyl. Vinyl parts are sometimes called "Profiles" and aluminum parts are sometimes called "Shapes" or "Extruded Shapes".

### *EQUIVALENT STATIC REACTION*

The reaction force from the maximum calculated resistance in a component applied as a load. This force is used to check the shear capacity of components and to design the component connections using a static design approach.

### *FIXED LITE*

A lite of glass in a window or door that does not operate (i.e. cannot be opened). It is usually the upper light of a single hung window. Sometimes the same as a picture window or fixed frame window.

### *FRAME*

The outer members of a window or door. The frame includes the head, sill or threshold, the two jambs and the meeting rail of a window.

### *FULLY TEMPERED GLASS (FT)*

A glass type that is heat treated and has about four times the compressive strength of regular annealed glass. FT is the same glass used by car manufacturers for side windows in automobiles. It is often called safety glass. The fully tempered glass tends to shatter into small cube like pieces upon failure.

### *GASKET*

A type of channel glazing that uses vinyl glazing material formed into a rectangular piece that fits around a particular size of glass. The gasket has welded corners to form a continuous cushion and seal. This type of glazing is usually found in sliding glass door units or commercial applications.

### *GLASS*

Any of a large class of materials with highly variable mechanical and optical properties that solidify from the molten state without crystallization. They are typically based on silicon dioxide (sand), boric oxide, aluminum oxide, or phosphorus pentoxide, generally transparent or translucent, and are regarded physically as super cooled liquids rather than true solids.

### *GLAZING*

The infill material held within the window frame. Various types of glass and/or plastic are the most common glazing materials. This term is also the physical act of installing such material.

### *GLAZING TAPE*

A preformed tape with adhesive on both sides used to glaze glass to a frame member.

### *HEAD*

The top or uppermost horizontal member or of the frame of a window or door. Sometimes called a header.

*HEADER*

The structural member in a building that spans over the upper portion of a window or door opening. (Also see Head)

*HEAT-STRENGTHENED GLASS*

This glass is produced in much the same way as tempered glass, but with lower levels of surface compression, 3500-7500 psi. The final product is two times stronger than annealed glass. The break pattern varies with level of surface compression with lower levels having a break pattern similar to annealed glass and higher levels resulting in patterns similar to tempered glass.

*INSULATED GLASS UNIT (IGU)*

A glass unit made up of two lites of glass, a spacer bar filled with a desiccant material placed between the two lites at the perimeter, and a sealant applied around the entire perimeter of the assembly. The space between the panes is filled with a dry inert gas before sealing. This creates an envelope of dead air which when used in a window or door, greatly reduces the passage of heat through the glass, thereby producing an energy savings at an increased material cost.

*INTERLAYER*

Any material used to bond two lites of glass and/or other glazing material together to form a laminate. For annealed glass the interlayer is normally a 0.030 in. thick polyvinyl butyral (PVB). Some applications use a thicker interlayer (0.060 or 0.090 inch interlayers are sometimes used in special applications).

*INTERMEDIATE MULLION*

For the purposes of this PDC-TR, those mullion which span between primary mullions.

*JAMB*

The sides or outermost vertical side members of a window or door unit.

*LAMINATED GLASS*

Two or more lites of glass bonded together by interlayer(s). When fractured, the interlayer tends to retain the glass fragments.

*LEVEL OF PROTECTION (LOP)*

Indicators established by DoD to characterize building damage and potential dangers to occupants. Table 2-2 of this document presents LOP's for blast loads.

*LINTEL*

A structural member, usually a steel angle or channel, designed to support the wall or siding above a window or door.

*LITE*

Another term for a single undivided panel (pane) of glazing used in a window assembly. Typically spelled "lite" in the industry literature to avoid confusion with light as in "visible light".

*MEETING RAIL*

One of the two horizontal members of a sliding sash which come together when in the closed position.

*MIL*

Unit of measure commonly used for reporting laminate interlayer or security window film thickness. 1 mil = 1/1000th of 1 inch.

*MONOLITHIC GLAZING*

A single ply of glazing without any laminations.

*MULL*

To join two or more individual windows together at mullions

*MULLION*

A horizontal or vertical member that holds together two adjacent lights of glass or windows or sections of curtain wall.

*MUNTIN*

A part of a window that divides a light of glass into smaller sections. A true muntin (the first "n" in "muntin" is silent) actually separates the pieces of glass. Insulated glass usually uses internal "false" muntins, which only appear to divide the glass into smaller lights. Muntins are normally either vertical or horizontal although diagonal and curved are also used.

*OPERABLE WINDOW*

A window that can be opened for ventilation.

*PANE*

A single lite of glazing. This term is also applied to the inner and outer panels of glazing in insulated glass units. See Lite.

*POLYCARBONATE*

Any of a family of thermoplastics marked by a high softening temperature and high impact strength. Polycarbonate is extensively used in ballistic and impact resistant window applications.

*PRIMARY MULLION*

For the purposes of this PDC-TR, those mullions which span between points of structural support.

*PRIMARY STRUCTURE*

The primary vertical and horizontal load carrying elements of the structure.

*PUNCHED WINDOW*

A window with single or multiple lites which fills an opening that appears to have been “punched” through the otherwise continuous wall system around it. The wall façade material is on all four sides of the window.

*RIBBON WINDOW*

A string of windows placed edge to edge forming a horizontal band around a building. They can be installed with or without exposed mullions and are generally connected to the head and sill.

*ROUGH OPENING*

The space in the wall of a structure into which a window or door is to be installed. This space is slightly larger than the actual frame size of the window or door. Shims are used at the anchor points to adjust the position of the frame in the opening and prevent movement after installation.

*SASH*

The portion of a window or skylight which includes the glass and framing sections which are directly attached to the glass. Normally, the moving segment of a window, although sash is sometimes referred to as fixed sash.

*SEALANT*

A compound used to fill and seal a joint or opening, as contrasted to a sealer, which is a liquid used to seal a porous surface. Also, the material used to seal the edges of insulated glass.

*SETTING BLOCK*

A small block of material, usually a rubber-like product but sometimes wood, placed between the edge of glazing and the frame to position and cushion the glass. These blocks are usually placed at the bottom of the glazing but sometimes are also used at the sides and top edge.

*SILICONE*

A plastic type material used for sealing cracks in window frames, and is used sometimes as a glazing compound. When used to anchor laminated glazing or attached film to the frame, a specialized *structural* silicone must be used; conventional silicone glazing is not acceptable in such applications. Also see “WET GLAZING”.

*SILL*

The threshold or lowest horizontal member of the frame of a window or door.

***SINGLE-DEGREE-OF-FREEDOM***

Single-degree-of-freedom (SDOF) systems are commonly used for the analysis of windows under blast-induced loads. Using this approach for dynamic analysis, a given structure or window component is reduced to an “equivalent” SDOF system and its dynamic deflections can be determined. Deflections determined from the SDOF system will be equivalent to the deflection of a specified point in the real structure or structural element. With the deflections known, basic structural analysis principles can then be used to proceed with the analysis and/or design. More sophisticated methods such as multi-degree-of-freedom (MDOF) or finite element methods may be required or preferred in some cases.

***SINGLE GLAZED***

A window or door that is glazed with a single sheet glass, as opposed to multiple glazing (insulated glass) which uses two or more lites of glass.

***SKYLIGHT***

A type of window installed in the roof of a structure to allow admittance of sunlight. These units can be fixed in place or they can be of a type that opens for ventilation. The glazing can be a single sheet or multiple and can be clear or tinted.

***SLANT RANGE***

The distance, taking into account horizontal and vertical offsets and angles, maintained between a building or portion thereof and the potential location for an explosive detonation

***SPANDREL GLASS***

The opaque areas of a building envelope which typically conceal structural columns, floors, and shear walls.

***STOREFRONT***

A non-residential system of doors and windows mulled together typically installed between floor and ceiling.

***STANDOFF DISTANCE***

The horizontal distance maintained between a building or portion thereof and the potential location for an explosive detonation.

***STILE***

Another name for the vertical side rails of a sash or a sash jamb.

***STRUCTURAL GLAZING***

See Wet Glazing.

***SUPPORTING STRUCTURAL ELEMENT***

Structural elements which frame the rough opening of the window or skylight system



### *TEMPERED GLASS*

A type of safety glass that has been heat treated so when it breaks it separates into very small pieces that reducing the possibility of injury. The result of heat treating are layers of high compression at the surfaces balanced by a high-tension layer through the center of the glass making it stronger than annealed glass. Once tempered, the glass will fracture if cut. Tempered glass is used in doors, windows located near doors, and other locations where safety is critical.

### *THERMAL BREAK/THERMALLY BROKEN*

A type of window that employs an insulating material in the sash and frame members to reduce the flow of heat either inward or outward. The outer portion of the frame and sash are separated from the inner portion. This type of frame (“thermally broken”) is mostly used in colder climates because it saves energy and reduces condensation on the inner surfaces of the window.

### *THREAT*

Threat is a certain weight of a particular explosive detonated at a specified distance away. TNT is typically used as the characteristic explosive. Threat is also applied to other types and methods of attack that are not addressed in this PDC TR.

### *TNT*

Trinitrotoluene (TNT), a pale yellow, solid organic nitrogen compound used chiefly as an explosive, prepared by stepwise nitration of toluene. Because TNT melts at 82° C (178° F) and does not explode below 240° C (464° F), it can be melted in steam-heated vessels and poured into casings. It is relatively insensitive to shock and cannot be exploded without a detonator. For these reasons, it is one of the most favored chemical explosives and is extensively used in munitions and for demolitions.

### *TNT EQUIVALENCE*

Threat charge weights are generally expressed in weight of TNT. When other explosives are considered in blast prediction, linear equivalency factors are generally applied to adjust the charge weight to an equivalent weight of TNT. Blast prediction tools can then be used with this equivalent weight.

### *WET GLAZING/ WET GLAZED*

The application of a bead of structural silicone to secure film of attached film windows and laminated glass to the window frame. The silicone bead is designed to resist membrane action of the laminate or film and is typically placed within the bite. For laminated panes in IGUs the structural silicone is placed only on the laminated pane (which is always on the interior side of the window). For single pane windows the silicone is placed on both sides of the pane. For attached film windows in retrofit applications the bead may be placed along the edge of the frame.

### *WINDOW*

An opening constructed in a wall or roof and functioning to admit light or air to an enclosure, usually framed and spanned with glass and sometimes mounted to permit opening and closing.

**This Page Intentionally Left Blank**

## APPENDIX A SBEDS DYNAMIC DESIGN PROCEDURE

### A-1 DESIGN OF WINDOW USING SBEDS-W

This section will cover the dynamic design procedure for the design and analysis of glazing when SBEDS-W is used. The procedure for frames and supporting structural elements are in the subsequent sections. (Clicking on the “Show Help Notes” button at the top of the Input page will enable users to view information describing various inputs and results by placing the cursor over any cell having a small red triangle in the upper right corner.)

#### A-1.1 Glazing Design Properties

The first inputs that the designer will need to know are the general window characteristics. These include the height and width of the window and also the distance from the floor to the bottom of the glazing, which are input directly on the Input page. Additionally, the boundary conditions for the window must be selected using the dropdown menu. The window boundary conditions represent the support of the glazing edges, as opposed to membrane attachment, and can be two-sided vertical, two-sided horizontal, or four-sided support. Other parameters need to be input using the “Input Window Properties” form as discussed below.

After the window characteristics are entered, the window properties can be input by clicking the “Input Window Properties” button on the Input page. (Window properties cannot be input until the general window characteristics are input.) The first step on the window properties screen will be to select either a single pane or double pane (IGU) window. Then the glazing type for the inner pane and if applicable, the outer pane is selected as monolithic, laminated, or filmed. If a laminated or attached filmed window is selected, the membrane boundary conditions will be available for selection. The membrane boundary conditions should be selected to match the Window Boundary Conditions previously selected on the Input page except in very unusual situations.

Next, the glass material, nominal pane thickness for the pane (or inner pane and the outer pane if applicable) and bite are input. SBEDS-W will automatically calculate the actual glazing thickness corresponding to the selected nominal thickness. For IGUs, the inner pane should always be laminated. If the bite is not specified (i.e. left blank, as is typically done) SBEDS-W will automatically calculate the bite required to prevent the pane from popping through the opening before reaching its ultimate flexural capacity, and will report either that value or the minimum recommended bite of 3/8”, whichever is greater. (See the SBEDS-W Users Guide for more information.) The calculated bite does not consider the width required to accommodate the structural silicone. It is recommended that the default Probability of Failure and Glass Failure Prediction Model (GFPM) flaw parameters be used. Note that the user should ALWAYS select “Defaults for Window Design” when designing windows for a new project or when assessing the capacity of existing windows. The Default Parameters for Window Design are correlated with test data on windows taken from existing buildings and therefore

account for the effects of pitting and scratching that typically occur over time. “Defaults for Analysis of Tested New Windows” should only be selected when SBEDS-W is being used for such purposes as analyzing data from tests involving new glass or for estimating the capacity of windows using new glass in preparation for testing.

If an IGU is selected, the airgap between panes also needs to be input. For laminated and attached film window types, interlayer or film material properties can be entered. It is recommended to change the interlayer or film thickness only as appropriate. It is not recommended to modify any of the other default values (e.g. tensile strength, Poisson’s ratio.) The lamination factor for laminated glazing in DoD projects should always be set to 0.75. Once all the input values are entered, clicking done will return the designer to the main SBEDS-W input page.

### **A-1.2 Design Requirements**

The next step is to enter the design requirements for the analysis. This consists of the blast parameters, time step, and required hazard level/level of protection. The blast parameters can be entered after clicking the input blast parameters button.

The first input box is used to determine what sort of blast load input will be used. Available inputs are manual pressure/time pairs, charge weight standoff combination, multiple charge weight standoff combinations, a pressure/time history file, or to determine the blast load causing a selected hazard. Additionally, the blast load phase and type will need to be input. It is normally conservative to run the analysis using positive phase only with no clearing effects and ignoring incidence angle (i.e. use angle of 0 or leave blank). Once all the input values are entered, clicking “Done” will return the designer to the main SBEDS-W input page.

Once the designer has returned to the main SBEDS-W input screen, the time step and hazard level criteria can be input. The time step is found in the Solution Control section and should not exceed the max recommended time step which is provided in the cell above. Also provided in the solution control section is a percent of critical damping input. This input should remain at the default 0.2% in order to stabilize the calculation.

The Hazard Level Criteria or Level of Protection (LOP) is entered by using a drop down menu to select the appropriate hazard level, which are described in ASTM F1642 as well as UFC 4-010-01. Along with hazard level the dropdown choices indicate the LOP that correlates to the ASTM F1642 hazard ratings and UFC 4-010-01 level of protection descriptions.

### **A-1.3 Results Summary**

After all the input has been entered, an analysis can be run by clicking the run analysis button. After the analysis is finished, the results summary section is automatically populated with the results of the analysis. At this point the user should check the Errors/Warnings box at the top of the Input page to determine whether SBEDS-W has identified any issues that may affect the results. (Note that SBEDS-W only checks for a

limited number of conditions that can cause errors. The User is responsible for verifying that all inputs and results are correct.) The User should also check the graphs on the Results page to see if the displacements, loads, etc. indicate any unexpected or unusual variations and that the window has reached its maximum response.

After verifying there are no significant issues with the analysis, the next item to check is the calculated hazard level of the window relative to the required hazard level. This is shown in the Results Summary on the Input page.

If the calculated Hazard Level is acceptable, the next result to check are the peak values from the window analysis. The peak displacements and resistances for the inner and outer pane are presented as well as the time that each occurred. If the User left the Bite value blank on the Window Properties Input form, then SBEDS-W will report the greater of the bite required to prevent the window from popping out of the frame before reaching its flexural capacity (including an allowance for off-center placement of the glazing in the frame) and the minimum recommended bite of 3/8". (This is for the typical case of laminated glazing where no bite was input. Other glazing types, such as polycarbonate, and cases where a Bite dimension was input by the User, the reported bite may be based on other factors. See the SBEDS-W documentation for further information.) Note that *the calculated bite does not consider the bite width required to accommodate the structural silicone*: that must be determined by the designer

The tension force in the membrane at maximum deflection and the ultimate tension force at failure are also presented. When calculating the required width of structural silicone to restrain the laminate (or attached film if applicable), the ultimate tension force should be used. Lastly, the maximum out of plane reaction force is given. This is an average value equal to maximum lateral resistance ( $R_{max}$ ) over window area divided by perimeter length along supports. This is the force that would be used for the design of the connections between the window frame and the supporting structural elements.

The last result is the fragment throw information. It is here where the specific throw distances and impact heights are presented. Peak window velocity and initial throw velocity are also given. It is the throw distances and impact heights which determine the hazard rating from ASTM F1642. (Near cell X8 Users can see the throw distance that would be calculated neglecting the wall at 3m used in the ASTM test procedure. This may be of interest when analyzing test data.)

#### **A-1.4 Results Tab**

In addition to the information in the Results Summary on the Input page, there is further important information presented on the Results page. The peak dynamic reactions are given for the long side and short side of the window in terms of pressures applied to the glazing. To determine the peak dynamic reaction load per unit width along the support, these pressures should be multiplied by the *full* window span length. (i.e. Use the full short span length for the reactions along the long side and the full long span length for the reactions along the short side for four side supported windows. Do not use 1/2 of the span.)

Glazing Dynamic Reaction Loads to be used as a blast load input type for frame member analysis can be saved from the Output Tab. (In this case SBEDS-W automatically doubles the reaction based on the assumption that the mullion supports two windows of the same size, make-up, and loading.)

## **A-2 DESIGN OF WINDOW FRAME USING SBEDS-W**

Window frames and mullions can be designed using SBEDS-W and choosing the Mullion Component type from the “Intro Tab”. In this approach the loading that would be applied to the glazing is conservatively assumed to be applied directly to the mullion, which ignores the “cushioning” effect of the glazing as it deforms and absorbs energy.

### **A-2.1 Mullion Properties**

The first parameters that a designer will need to input will be the span, spacing, and boundary conditions for the mullion. The spacing value should be the width of glazing which the mullion supports. For example, if in a curtain wall system, the mullions are spaced at 5 feet, the spacing would be 5 feet. For a punched window of 5 foot width, the spacing would be 2.5 feet since the opposite mullion takes the other half of the window load.

The mullion properties are entered by clicking the “Input Mullion Properties” button. From this dialog box, the mullion shape and properties are input. These include thermal breaks and inserts within the mullion section, when applicable. Specific cross-sectional geometric properties are input by clicking the “Edit/Input Mullion Dimensions” button. Within this box, specific mullion dimensions are input, which are then used by SBESS-W to calculate the section properties of the mullion. Once all the data is input, clicking “Done” will return the designer to the main input screen.

### **A-2.2 Design Requirements**

The next step is to enter the design requirements for the analysis. This consists of the blast parameters, time step, supported weight, loaded area factor, and required response criteria. The blast parameters can be entered after clicking the input blast parameters button.

The first input box is used to determine what sort of blast load input will be used. Available inputs are manual pressure/time pairs, charge weight standoff combination, multiple charge weight standoff combinations, a pressure/time history file, or to determine the blast load causing a selected hazard. Additionally, the blast load phase and type will need to be input. For the most conservative results, run the analysis using positive phase only with no clearing effects and ignore any incidence angle. Once all the input values are entered, clicking “Done” will return the designer to the main SBEDS-W input page.

Once the designer has returned to the main SBEDS-W input screen, the time step, supported weight, loaded area factor, and response criteria can be input. The time step is found in the solution control section and should not exceed the max recommended time step, which is provided in the cell above. Also provided in the solution control section is a percent of critical damping input. This input should be taken as appropriate for the frame material type.

The supported weight should be taken as attached weight that moves through the same deflection as the mullion. This would be equal to the weight per unit area of the supported glazing and any supported wall. An area-weighted average can be used if both are present. The loaded area factor ( $A_f$ ) accounts for loads that are applied by secondary framing members that are of varying spans. For the most conservative results the loaded area factor should be taken as 1.0.

When selecting the response criteria, either steel, aluminum, or user defined response limits can be selected using a drop down menu. After the material is selected, then the appropriate level of protection can be selected from the next drop down menu.

After all the input has been entered, an analysis can be run by clicking the “Run Analysis” button.

### **A-2.3 Results Summary**

After the analysis is finished, the Error/Warnings box and inspect the graphs on the Results page should be checked to determine if there were any issues with the analysis.

The information at the top of the Results Summary section on the Input page will indicate whether the component response is within the limits of the selected response criteria.

The next items summarize the peak values from the mullion analysis. The peak displacements for inbound and rebound and the maximum and minimum resistances are provided along with the time that each occurs.

The last results displayed are the equivalent static reactions. The ultimate shear (i.e. shear based on the ultimate flexural capacity of the member, also referred to as the equivalent static reaction) at each support is given for the mullion and, if applicable, the insert. The maximum shear, which is the worst case support reaction, is provided for use in designing connections to the support. (If an insert is used the Summed Maximum Reaction is reported and is equal to the combined ultimate reaction of the insert plus mullion at the support with the greatest reaction.) Next, the shear strength of the mullion (and insert, if applicable) is checked and compared to the ultimate shear at the supports. Lastly, if an insert is used, the load is provided for design of the connection between the insert and the mullion. If the insert is non-composite, the resistance provided by the insert and by the mullion at the maximum calculated deflection is shown. This information indicates how much load is resisted by each component.

#### **A-2.4 Results Tab**

In addition to the results summary, there is additional information presented in the results tab found at the bottom of the window. Here the peak dynamic reactions are given for the supports.

### **A-3 DESIGN OF SUPPORTING STRUCTURE USING SBEDS**

Once the window and mullion analysis has been performed using SBEDS-W, the supporting structural elements can be designed using SBEDS. The applicable wall material module should be used for this analysis. The main difference between analyzing the supporting structural elements compared to analyzing a wall element is to account for the width of the window. This is handled by either increasing the element spacing or utilizing a  $B_w$  factor.

One way of analyzing window supporting structural elements is to use an increased member spacing. This increase takes into account the additional width of wall that must transfer load back to the element due to the addition of a window. This is typical for studs, both wood and metal. The spacing value is equal to half the typical element spacing, plus half of the window width, or the tributary width of that element.

The  $B_w$  factor for analysis of supporting structural elements is generally applicable to masonry or concrete supports. The  $B_w$  factor is a ratio of the width resisting a blast load over the loaded width. For the case of a pier between two windows it would be the pier width divided by the center to center distance of those windows. This ratio will always be greater than zero but less than or equal to one.

#### **A-3.1 Results**

Regardless of which approach is taken to analyze the supporting structural elements, the adequacy of the system is still checked against the typical response limits for the material being analyzed. This will be either one or a combination of a ductility ratio and a rotational limit. The values will vary depending on the level of protection and the type of element, (i.e. primary or secondary). Additionally, the shear capacity of the section will be checked to ensure the member doesn't fail in shear. The next step is to design the connection of the supporting structural element.

#### **A-3.2 Connection Design**

Once the supporting structural element has been designed, its connection to the primary structure should then be designed using the appropriate strength reduction factors for the material being used. This can be done two different ways; one by using the member's ultimate resistance, and the other by using the maximum resistance of the member generated during the blast load.



By using the member's ultimate resistance, the connection design will be conservative since that would be the most load that could ever be applied to the connection. Using the maximum resistance of the member developed under the blast loading, a lighter connection may result since it is only designed for the given load case. Since blast-loaded members will in many cases be driven beyond the elastic range, the maximum resistance will often be equal to the ultimate resistance. In cases where this does not occur, connections designed for the maximum resistance may fail if the actual blast load is greater than the assumed blast load; therefore, for a conservative design or where the blast load is uncertain, the ultimate reaction should be used. However, if the ultimate resistance of the member is much higher than the maximum resistance, using the maximum resistance for the connection design would be appropriate. Regardless of which method is chosen, all failure mechanisms should be checked for the type of connection which is being designed.

**This Page Intentionally Left Blank**

## APPENDIX B DESIGN EXAMPLES

### B-1 INTRODUCTION

The following examples are provided to show designers the proper design methods to use and how to interpret the results of various analyses.

Please note that in order to keep this document openly distributable, charge weights and standoff are different than the Charge Weights I and II from UFC 4-010-01. These examples provide guidance on only a specific method to analyze the window.

### B-2 EXAMPLE 1 – SINGLE PANE WINDOW, STATIC DESIGN

**Problem Statement:** Statically design the glazing for a 64 in tall by 38 in wide single pane window for 88 lbs at 100 ft.

**Solution:** First determine the equivalent 3-second duration load from ASTM F 2248-09, FIG. 1. It is found to equal 60.2 psf as shown in Figure B-1.

Figure B-1 Determination of 3-Second Duration Equivalent Design Load

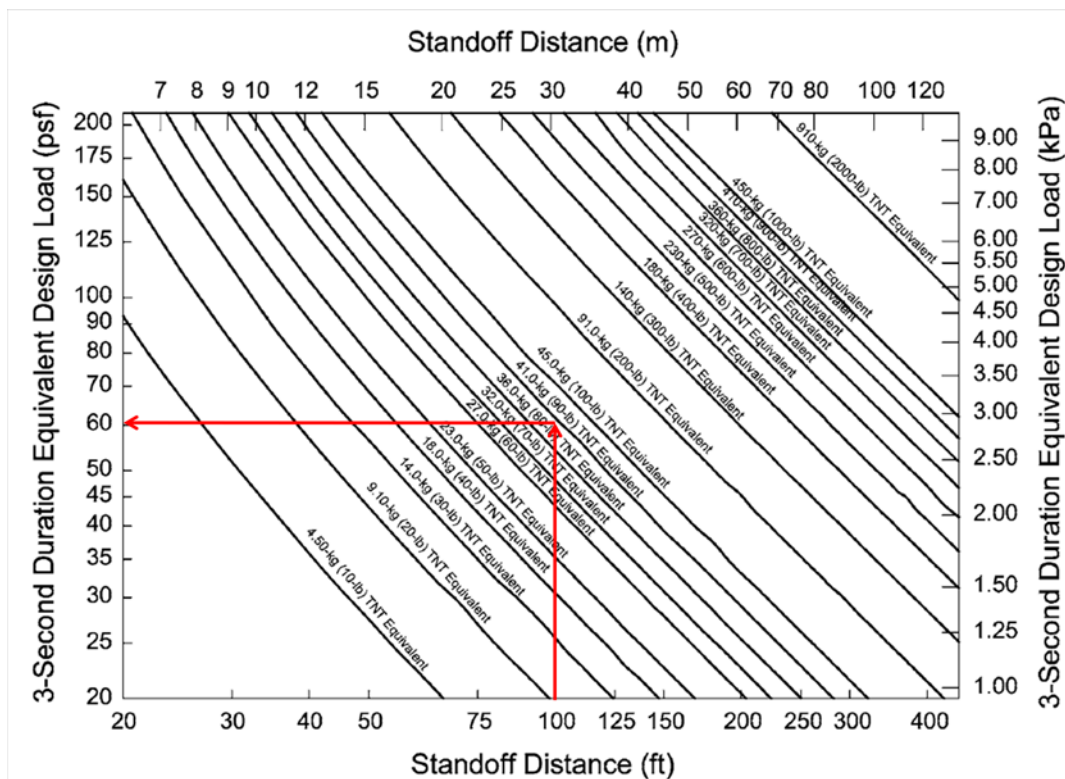

Adapted, with permission, from ASTM Standard ASTM F2248-09, Standard Practice for Specifying an Equivalent 3-Second Duration Design Loading for Blast Resistant Glazing Fabricated with Laminated Glass, copyright ASTM International, 100 Barr Harbor Drive, West Conshohocken, PA 19428. A copy of the complete standard may be obtained from ASTM International, [www.astm.org](http://www.astm.org).)

Use ASTM E 1300-09a to determine a window with a load resistance (LR) greater than the equivalent 3-second load, starting with a 1/4" laminated window with a minimum of 0.030" PVB interlayer. A 1/4" laminated lite yields a LR of 55.4 psf which is less than the 60.2 psf 3-second load.

$$LR_{1/4} = NFL(GTF) \rightarrow 55.4(1.0) = 55.4 \text{ psf} < 60.2 \text{ psf} \quad \times NG$$

Next, try a 5/16" thick laminated lite. The 5/16" lite has a LR of 79.7 psf which is larger than the 3-second load and is thus acceptable. Both Nonfactored Load (NFL) determinations are shown in Figure B-2 and Figure B-3. The final glass layup is 5/16" laminated lite with 0.030" PVB interlayer.

$$LR_{5/16} = NFL(GTF) \rightarrow 79.7(1.0) = 79.7 \text{ psf} < 60.2 \text{ psf} \quad \checkmark ok$$

Figure B-2 Determination of NFL for 1/4" laminated glass

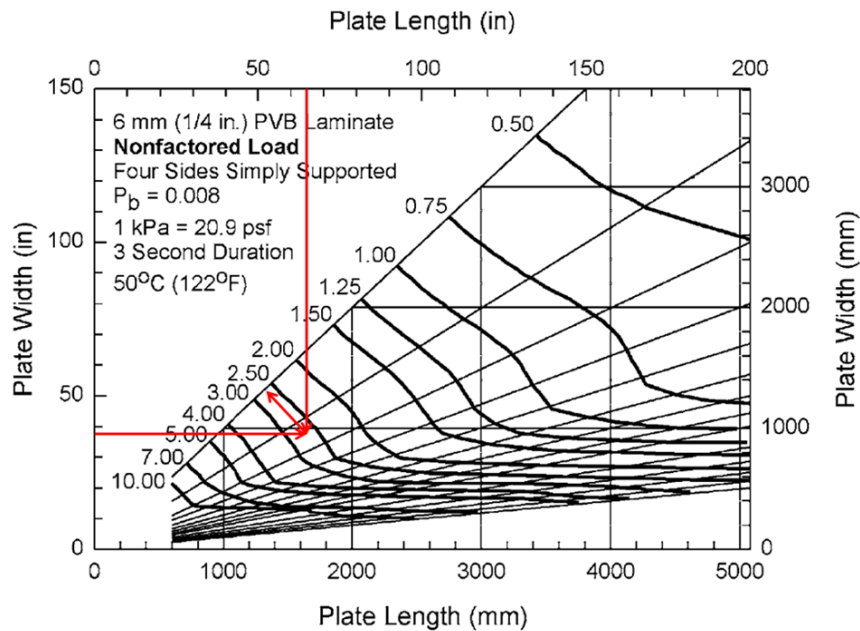

Adapted, with permission, from ASTM Standard ASTM E 1300-09a, Standard Practice for Determining Load Resistance of Glass in Buildings, copyright ASTM International, 100 Barr Harbor Drive, West Conshohocken, PA 19428. A copy of the complete standard may be obtained from ASTM International, [www.astm.org](http://www.astm.org).)

Figure B-3 Determination of NFL for 5/16" laminated glass

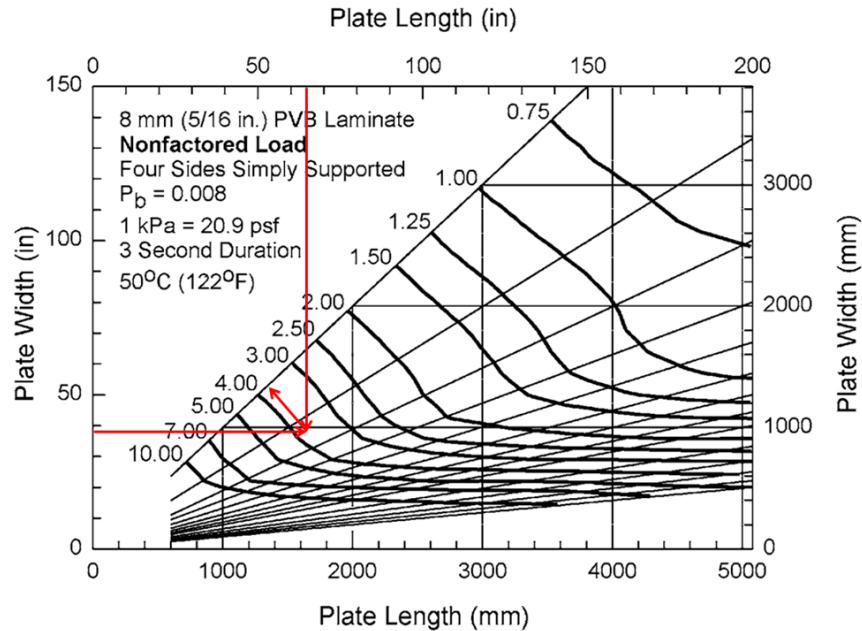

Adapted, with permission, from ASTM Standard ASTM E 1300-09a, Standard Practice for Determining Load Resistance of Glass in Buildings, copyright ASTM International, 100 Barr Harbor Drive, West Conshohocken, PA 19428. A copy of the complete standard may be obtained from ASTM International, [www.astm.org](http://www.astm.org).)

### B-3 EXAMPLE 2 – IGU WINDOW, STATIC DESIGN

**Problem Statement:** Statically design the glazing, framing, bite, and connection requirements for a 64 in tall by 38 in wide IGU window for 88 lbs at 100 ft.

**Solution:** First determine the equivalent 3-second duration load from ASTM F 2248-09, FIG. 1. It is found to equal 60.2 psf as shown in Example 1.

Use ASTM E 1300 to determine a window with a load resistance greater than the equivalent 3-second load, starting with a 1/4" laminated window with a minimum of 0.030" PVB interlayer inner pane and a 1/4" monolithic outer pane.

The process for IG windows supported on four sides is described in Section 6.11 of ASTM E 1300. The NFL for each lite is found using the charts in Appendix A. Lite 1 will be the monolithic pane while Lite 2 is the laminated pane. NFL1 is found to be 51.2 psf using FIG. A1.6 and NFL2 is found to be 55.4 psf using FIG. A1.28. NFL determinations are shown in graphically in Figure B-4 and Figure B-5.

Figure B-4 Determination of NFL for 1/4" monolithic glass

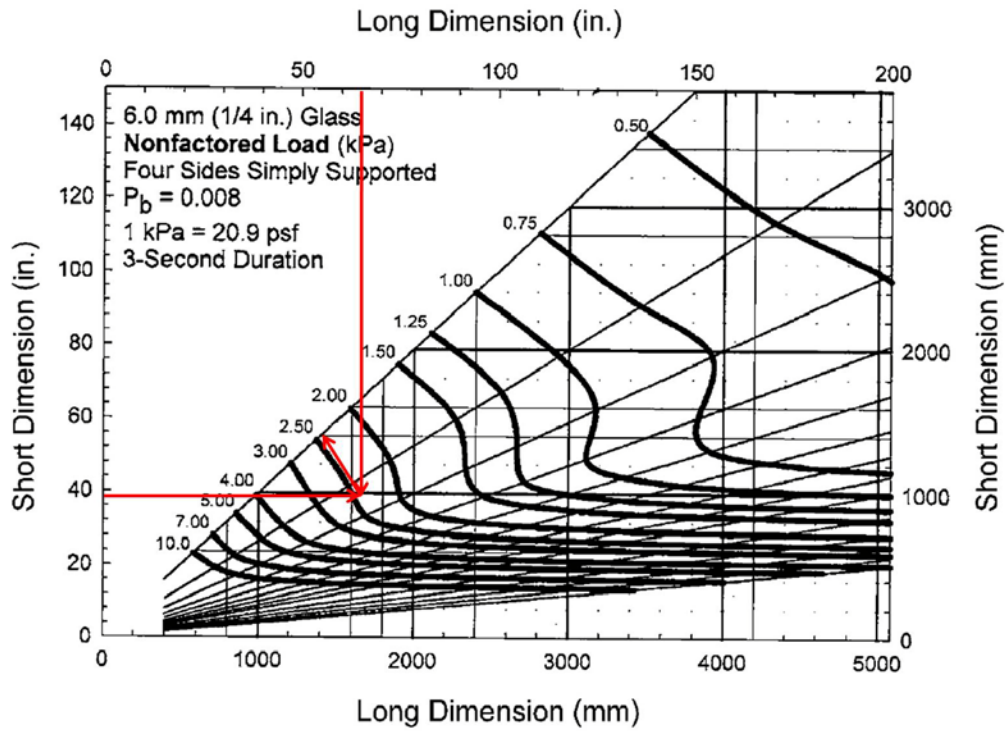
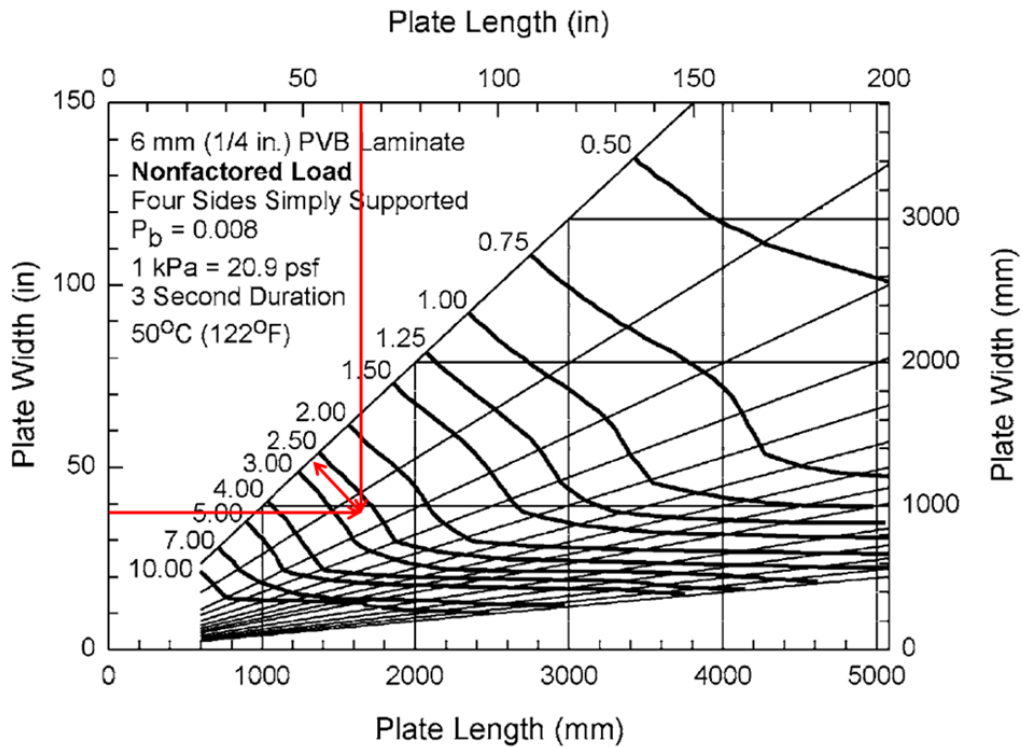

Figure B-5 Determination of NFL for 1/4" laminated glass



Adapted, with permission, from ASTM Standard ASTM E 1300-09a, Standard Practice for Determining Load Resistance of Glass in Buildings, copyright ASTM International, 100 Barr Harbor Drive, West Conshohocken, PA 19428. A copy of the complete standard may be obtained from ASTM International, [www.astm.org](http://www.astm.org).)

The Glass Type Factor (GTF) for each lite is determined from Table 2 in ASTM E 1300 and GTF1 and GTF2 were both found to be 0.9. The Load Share Factor (LS) for each lite is determined from Table 5 in ASTM E 1300 and LS1 and LS2 were both found to be 2.0 since both lites are the same thickness.

Now, the LR for each lite can be computed by multiplying NFL, GTF, and LS all together. Multiplying the values, LR1 was found to be 92.2 psf and LR2 to be 99.7 psf. The system load resistance is equal to the lower of the values, hence the LR for this design is 92.2 psf which is larger than the 3 second load of 60.2 psf so the glazing is acceptable.

$$LR_x = NFL_x GTF_x LS_x$$

$$LR_1 = 51.2(0.9)2 = 92.2 \text{ psf}$$

$$LR_2 = 55.4(0.9)2 = 99.7 \text{ psf}$$

$$LR = 92.2 \text{ psf} > 60.2 \text{ psf} \quad \checkmark \text{ok}$$

Next, the framing is designed using twice the LR found above, which is equal to 184.4 psf. This load is then divided into a long span and short span line load which yields 17.1 lbs/in and 12.2 lbs/in respectively. The deflection limits of L/60 for the long and short span are found to be 1.1" and 0.63" respectively. Using a simple beam deflection equation for an aluminum frame with a modulus of elasticity of 10,000,000 psi, the minimum required moment of inertia can be determined. By providing a frame with a moment of inertia of at least 0.334 in<sup>4</sup> in the long direction and 0.053 in<sup>4</sup> in the short direction, the deflection will be less than L/60 for each, and thus be acceptable.

$$w = 2(LR) \rightarrow 2(92.2) = 184.4 \text{ psf}$$

$$w_{long} = \frac{w(\text{Area})}{\text{Perimeter}} \rightarrow \frac{184.4 \left[ \left( \frac{38}{2} \right)^2 + (64 - 38) \left( \frac{38}{2} \right) \right]}{144(64)} = 17.1 \text{ lb/in}$$

$$w_{short} = \frac{w(\text{Area})}{\text{Perimeter}} \rightarrow \frac{184.4 \left[ (38) \left( \frac{38}{2} \right) \left( \frac{1}{2} \right) \right]}{144(38)} = 12.2 \text{ lb/in}$$

$$\Delta_{max_{long}} = \frac{L}{60} \rightarrow \frac{64}{60} = 1.1''$$

$$I_{long} = \frac{5wl^4}{384E\Delta_{long}} \rightarrow I_{long} = \frac{5(17.1)64^4}{384(10,000,000)1.1} = 0.340 \text{ in}^4$$

$$\Delta_{max_{short}} = \frac{L}{60} \rightarrow \frac{38}{60} = 0.63''$$

$$I_{short} = \frac{5wl^4}{384E\Delta_{long}} \rightarrow I_{short} = \frac{5(12.2)38^4}{384(10,000,000)0.63} = 0.053 \text{ in}^4$$

Using ASTM F 2248-09 to determine the bite requirement the minimum depth is found to be 3/8" with a maximum of 1/2". Since the window is an IG, the structural silicon only needs to be applied to the interior, laminated, lite.

The connection load determined from ASTM F 2248-09 is twice the LR since the peak blast pressure is larger than one half the LR. This load can be transferred into a single force yielding 3,114 lbs, which must be resisted by the connections.

$$w_{total} = LR(Area) \rightarrow \frac{184.3}{144} [(38)(64)] = 3,114 \text{ lb}$$

For this example, a self drilling screw was chosen with an ultimate shear capacity of 2,016 lbs. By dividing the connection load by the screw capacity the number of connectors required can be determined. For this example only two connectors are required, but to provide proper support for the window four connectors are used, one at each corner fastened into the jam through the vertical frame member.

#### **B-4 EXAMPLE 3 – CURTAIN WALL, STATIC DESIGN**

**Problem Statement:** Statically check the curtain wall design shown below for 65 lbs at 80 ft. Assume the as designed glazing is an IGU with 1/4" AN outer pane, 1/2" air space, and 1/4" AN laminated inner pane with 0.030" PVB. Also, assume the framing members have a moment of inertia of 2.291in<sup>4</sup>.



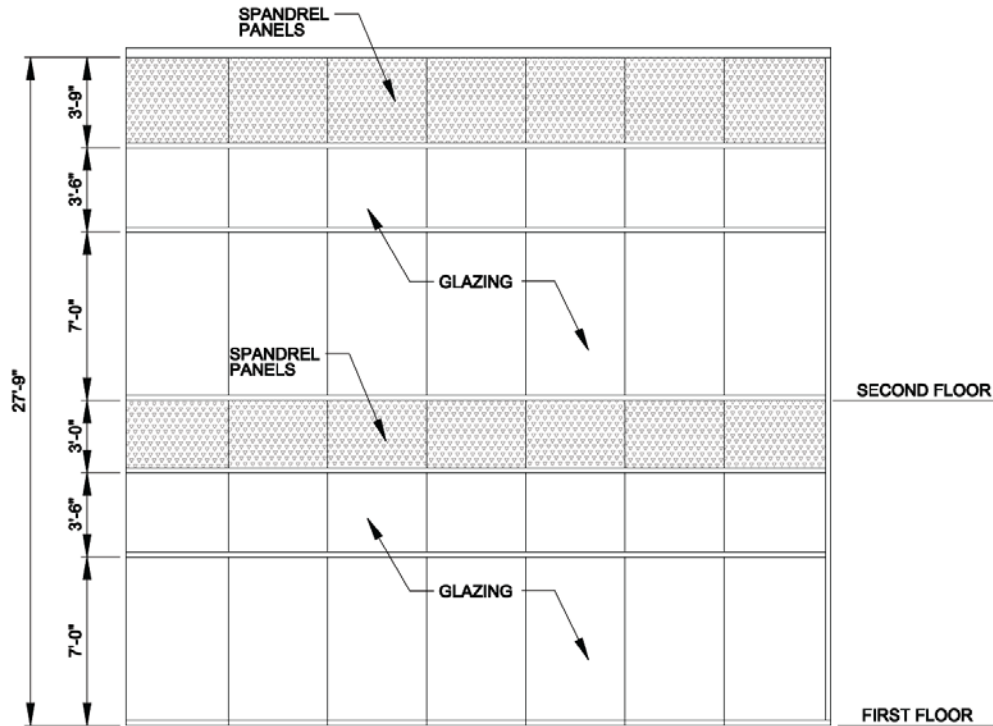

**CURTAIN WALL ELEVATION**

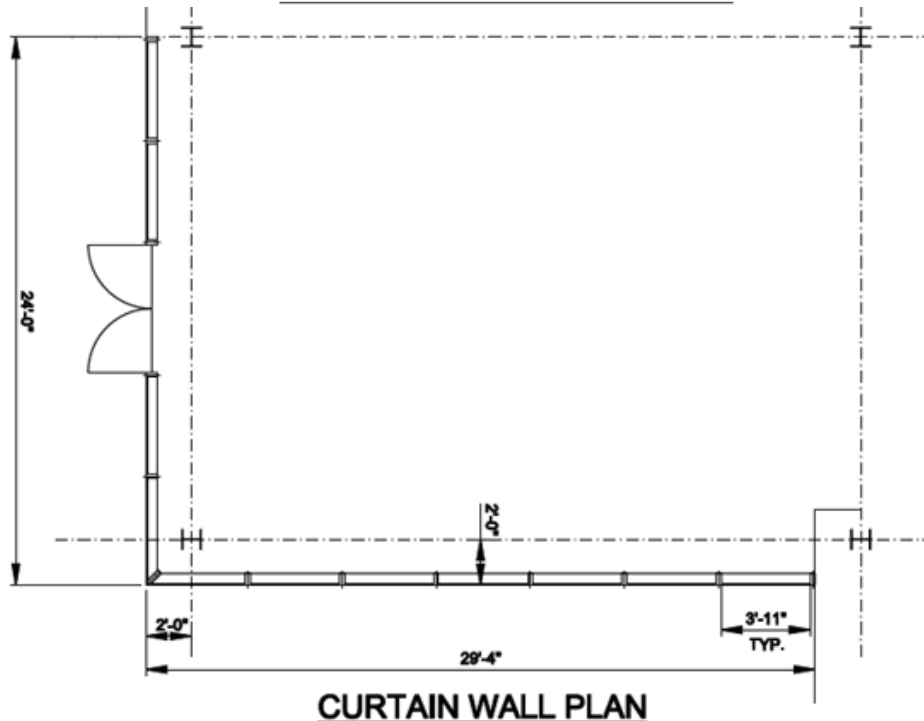

**CURTAIN WALL PLAN**

**Solution:** The first step is to design the glazing. Using the ASTM F 2248 method as shown in Examples 1 and 2, the equivalent 3-sec design load was determined to be 59 psf. Then by using the ASTM E 1300 method also shown in Examples 1 and 2, the glazing resistance was determined to be 64.8 psf for the larger pane and 125 psf for the smaller pane. The spandrel glass was determined to have a glazing resistance of 136

psf. Since the load resistance for all three panes is greater than the 3-second load, the glazings are acceptable.

The primary mullions for this example are those which span vertically. The assumption here is that the vertical mullions span continuously from floor to floor. The design load for the primary mullions is twice the glazing resistance, which is 272 psf for the spandrel pane, 250 psf for the small pane, and 129.6 psf for the large pane. This load is applied to the tributary width of the glazing. For this example a weighted average load will be used in the check. The calculation is shown below. For this example, Area 1 is the large pane, Area 2 is the small pane, and Area 3 is the spandrel pane.

$$LR_{avg} = \frac{[LR_1(Area_1)] + [LR_2(Area_2)] + [LR_3(Area_3)]}{[(Area_1) + (Area_2) + (Area_3)]} \rightarrow$$

$$\frac{129.6(47)(84) + 250(47)(42) + 272(47)(36)}{(47)(84) + (47)(42) + (47)(36)} = 192.5 \text{ psf}$$

$$w_{line} = LR_{avg}(Width) \rightarrow \frac{192.5}{144}(47) = 62.8 \text{ lb/in}$$

$$\Delta_{max} = \frac{L}{60} \rightarrow \frac{162}{60} = 2.7''$$

$$I = \frac{5wl^4}{384E\Delta} \rightarrow I = \frac{5(62.8)162^4}{384(10,000,000)2.7} \rightarrow I_{min} = 20.8 \text{ in}^4$$

This means that the 6x4x1/4 HSS steel tube provided with a moment of inertia of 20.9 in<sup>4</sup> is adequate.

The intermediate mullions only need to be designed for the deflections limits. The calculations are shown below.

$$LR_{avg} = \frac{[LR_1(Area_1)] + [LR_2(Area_2)]}{[(Area_1) + (Area_2)]} \rightarrow$$

$$LR_1 = \frac{129.6(47)\left(\frac{84}{2}\right) + 250(47)\left(\frac{42}{2}\right)}{(47)\left(\frac{84}{2}\right) + (47)\left(\frac{42}{2}\right)} = 169.7 \text{ psf}$$

$$LR_2 = \frac{250(47)\left(\frac{42}{2}\right) + 272(47)\left(\frac{36}{2}\right)}{(47)\left(\frac{42}{2}\right) + (47)\left(\frac{36}{2}\right)} = 260.1 \text{ psf}$$

$$LR_3 = \frac{129.6(47) \left(\frac{84}{2}\right) + 272(47) \left(\frac{36}{2}\right)}{(47) \left(\frac{84}{2}\right) + (47) \left(\frac{36}{2}\right)} = 172.3 \text{ psf}$$

$$w_{1line} = LR_1(Height) \rightarrow \frac{169.7}{144} (63) = 74.2 \text{ lb/in}$$

$$w_{2line} = LR_2(Height) \rightarrow \frac{260.1}{144} (39) = 70.4 \text{ lb/in}$$

$$w_{3line} = LR_3(Height) \rightarrow \frac{172.3}{144} (60) = 71.8 \text{ lb/in}$$

Condition 1 is the controlling condition since the line load is the highest. This is the mullion between the large pane and small pane.

$$\Delta_{max} = \frac{L}{60} \rightarrow \frac{47}{60} = 0.78''$$

$$I = \frac{5wl^4}{384E\Delta} \rightarrow I = \frac{5(74.2)47^4}{384(10,000,000)0.78} \rightarrow I_{min} = 0.6 \text{ in}^4$$

Which means the standard mullion with a moment of inertia of 2.291 in<sup>4</sup> is acceptable.

## B-5 EXAMPLE 4 – IGU WINDOW, DYNAMIC DESIGN

**Problem Statement:** Dynamically design the glazing, framing, bite, and connection requirements for a 64 in tall by 38 in wide IG window for 88 lbs at 100 ft for a very low level of protection.

**Solution:** First, the glazing is designed using SBEDS-W. Input the proper window height, width and distance from floor in the input boxes. The window height can be assumed to be 24 in. The input can be seen in Figure B-6

Figure B-6 Example 4 Window Input

<b>User Info: Fill in Yellow Cells, See Note Below for White Cells</b>	
Window Height; H	64 inch
Window Width; W	38 inch
Distance from Floor to Bottom of Glazing:	24 inch
Window Boundary Conditions:	Supported on Four Sides <span style="float: right;">▼</span>

Next, the window properties are specified. Input a laminated, annealed glass window of 1/4" with 0.030" PVB thickness as the inner pane and a monolithic annealed 1/4" outer pane. Use the default POF (500/1000) and interlayer properties and a lamination factor of 1.0. Leave the Bite blank as SBEDS-W will automatically calculate the bite required. (Note that *the calculated bite does not consider the width required to accommodate the structural silicone*: that must be determined by the designer.) Under GFPM Flow parameters select "Default for Window Design (Recommended)". The input can be seen in Figure B-7 below.

Figure B-7 Example 4 Window Properties Input

Single Pane  
 IGU (Double Pane)

**Inner Pane**

Window Type: Laminated

Membrane Boundary Conditions: Four Sides Attached

Glazing Material (See Note 1): Annealed

Nominal Total Pane Thickness (in): 1/4

Actual Thickness (in): 0.26

Bite (in) (See Note 2):

Pane POF (breaks/1000)\*: 500

GFPM Flow Parameters\*: Defaults for Window Design (Recommended)

**Outer Pane**

Window Type (See Note 3): Monolithic

Membrane Boundary Conditions: N/A

Glazing Material (See Note 1): Annealed

Nominal Pane Thickness (in): 1/4

Input Actual Thickness (in): 0.22

Bite (in) (See Note 2):

Pane POF (breaks/1000)\*: 500

GFPM Flow Parameters\*: Defaults for Window Design (Recommended)

\*See comments in cells B41 and B43

**Interlayer Properties**

PVB Thickness (in): 0.03

PVB Tensile Strength (psi): 3500

PVB Lamination Factor: 1

PVB Poisson's Ratio: 0.47

**This area not used for monolithic panes**

Airgap between Panes (in): 0.5

Notes:

1a): For input of laminated glazing with more than 2 panes, see Note 7 on Input sheet

1b): Polycarbonate glazing only available for monolithic window type

2: Leave blank to calculate bite.

**Done**

Notes:

3) Film not available for outer window.

The next blast parameters input are the charge weight and standoff distance. For this example, negative phase will be ignored along with any clearing effects and angle of incidence. The blast load parameter input can be seen in Figure B-8.

Figure B-8 Example 4 Blast Parameter Input

Blast Load Input Type  
Charge weight and standoff (W-R)

Gravity Displacement  
None (vertical component)

Explosive Type  
TNT

TNT equiv. Factor  
1

W(lb)  
88

R(ft) (See Note)  
100

Note: R= distance from center of explosive source to center of component

Blast Load Phase  
Positive phase only

Blast Load Type  
Reflected without Clearing

Incidence Angle  (0-90 degrees)

The last input before the analysis can be run is the time step and the hazard level criteria. The time step should not exceed the maximum recommended time step. The default percent of critical damping is used. The hazard level for this analysis is input as low hazard, or very low level of protection. Once all the proper input is entered, SBEDS-W can be run. The results of the analysis are summarized at the bottom right of the Input page, and are shown in Figure B-9. The given window has a Minimal Hazard level, which means the glazing fractured but remained in the frame. A Minimal Hazard rating corresponds to a Medium or Low Level of Protection. The required bite is 0.38" or 3/8".

Figure B-9 Example 4 Window Results Summary

Results Summary					
Hazard Level Criteria:		Minimal Hazard (MLOP)			
Calculated Hazard Level:		Minimal Hazard (Window Cracked but in Frame)			
Window Response is OK					
Peak Values from Window Analysis					
	Inner	Outer		Inner	Outer
$X_{max}$ (inch) =	5.38	Failed	at time (ms) =	29.52	7.07
$R_{max}$ (psi) =	1.69	1.83	at time (ms) =	29.52	7.07
Required Bite Depth (inch)				0.38	0.38
Tension force in PVB at maximum deflection (lb/in)*				57	
Ultimate tension force in PVB at window failure (lb/in)*				105	
Maximum out-of-plane reaction force (both panes) (Note 6):				36	lb/in
Fragment Throw Information <sup>4,5</sup>					
Fragment throw distance into room				N/A	ft
Fragment impact height				N/A	ft
Peak window velocity at window failure				N/A	ft/sec
Initial velocity for throw(Avg vel. of whole window)				N/A	ft/sec
* Can be used to design glazing connection to window frame. Prescriptive requirements in ASTM F2248 can also be used.					

The next step is to design the window frame for the blast load using the SBEDS-W mullion module. Start with a given aluminum frame as shown in Figure B-10 below. Note that torsion is neglected (The shear center for a channel will be very near the location of the window reaction, so if the member is supported at the web there will be little torsion developed.) In-plane forces on frames are also neglected.

Figure B-10 Aluminum Frame Section Properties

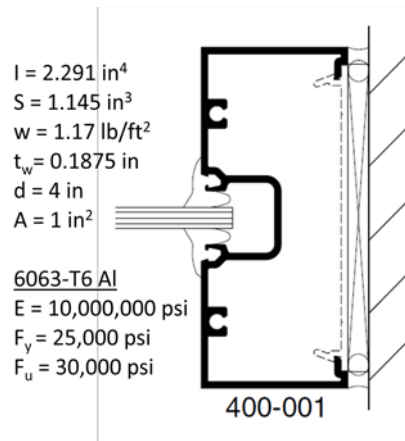

The mullion module should be opened in SBEDS-W and all proper input entered into the worksheet. As previously discussed, the span in feet should be taken as the full length of the frame member and the spacing should be half of the window span. See Figure B-11

Figure B-11 Example 4 Mullion Input

User Info: Fill in Yellow Cells, See Note Below for White Cells	
Span, L:	5.333333333 ft
Spacing, B:	1.583333333 ft
Boundary Conditions:	Simple-Simple, Uniformly Loaded
Response Type:	Flexural

The mullion section properties can be entered as a user defined section as shown in Figure B-12. After the section properties are input, the mullion material can be defined. The blast parameter inputs are the same as in the window module of SBEDS-W as shown above. The supported weight should be the weight of the glass. In this case 1/4" glass is 3 psf and 0.030" PVB is 0.17 psf resulting in a total of 6.17 psf support weight since there are two lites of 1/4" glass. Run the analysis as a Charge Weight and Standoff with 88 lbs at 100 ft standoff.

Figure B-12 Example 4 Mullion Properties Input

Once all the proper input has been entered, the problem can be run. At the lower right corner is a results summary, which displays the calculated response. Aluminum response limits for a Very Low Level of Protection are a ductility ratio of 10 and a rotational limit of 10 degrees. Based on these response limits, this section is acceptable. Additionally, the connection load can be determined from this analysis. Using the Peak Reactions as the required connection load ensures that the frame will be sufficiently anchored. For this example, the connection must have a minimum capacity ( $V_u$ ) of 2,273 lbs as shown in Figure B-13.

Figure B-13 Example 4 Mullion Results Summary

Results Summary			
$\theta_{max} = 2.02$ deg.	Design Criteria: VLLOP/Secondary-NS		
$\mu = 1.67$	Response OK compared to input design criteria		
$X_{max}$ Inbound = 1.13 in	at time =	11	msec
$X_{min}$ Rebound = -0.21 in	at time =	25	msec
$R_{max} = 3.74$ psi	at time =	11	msec
$R_{min} = -3.63$ psi	at time =	25	msec
Shortest Yield Line Distance to Determine		32.0	in
Equivalent Static Reactions			
<i>Peak Reaction (<math>V_u</math>) and Shear Information Based on Ult. Flexural Resistance</i>			
$V_u$ at Support A =		Mullion	lb
$V_u$ at Support B =		2,273	lb
Maximum $V_u$ for Connection		2,273	lb
<i>Shear Capacity</i>			
Shear Area: $A_v$		Mullion	in <sup>2</sup>
Shear Capacity: $V_c$		1.00	lb
Shear Check		17,391	OK

**B-6 EXAMPLE 5 – CURTAIN WALL, DYNAMIC DESIGN**

**Problem Statement:** Dynamically check the glazing and framing requirements for the curtain wall in Example 3 for 80 lbs at 100’.

**Solution:** First the glazing is checked using SBEDS-W. The glazing input follows the same procedure as outlined in Example 4 above. The height above floor can be calculated by finding the distance of the bottom of the glazing from the floor. For this example it is 0”, 84”, and 126” for the large pane, the small pane, and the spandrel glass respectively.

Each window pane is analyzed for the specified blast load to determine its adequacy. After all three analyses, the results show that the specified windows only have a Minimal Hazard, which means the glazing fractured but remained in the frame. A Minimal Hazard rating corresponds to a Medium or Low Level of Protection.

The next step is to check the frames for the blast load by using SBEDS and using the area tributary to the window frame and the applicable level of protection based on response limits. The provided frame is shown in Figure B-14 below.

Figure B-14 Aluminum Curtain Wall Section Properties.

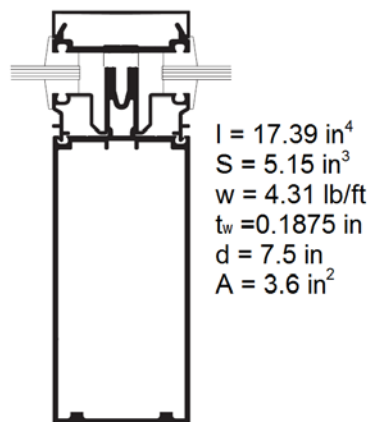

The mullion module should be opened in SBEDS-W and all proper input entered into the worksheet. The span should be taken as the span of the frame in feet and the spacing should be half of the glazing span on each side of the frame. The material and section properties should be entered as a tube section. The supported weight should be the weight of the glass. In this case 1/4” glass is 3 psf and 0.030”PVB is 0.17 psf resulting in a 6.17 psf supported weight since there are two lites of 1/4:” glass. Run the analysis as a Charge Weight and Standoff with 80 lbs at 100 foot standoff. The frame properties input and results summary for the analysis are shown in Figure B-15 and Figure B-16 respectively.



Figure B-15 Example 5 SBEDS input for primary mullion

**Mullion Input**

a (in)

b (in)

c (in)

d (in)

e (in)

f (in)

t1 (in)

t2 (in)

t3 (in)

t4 (in)

t5 (in)

**Calculate Mullion Properties**

Calculated Mullion (Only) Properties

S (in <sup>3</sup> )	I (in <sup>4</sup> )	A (in <sup>2</sup> )
5.15	17.39	3.59

Figure B-16 Example 5 SBEDS results for primary mullion

Results Summary			
$\theta_{max} = 3.49$ deg.	Design Criteria: VLLQP/Secondary-NS		
$\mu = 1.93$	Response OK compared to input design criteria		
$X_{max}$ Inbound = 4.93 in	at time =	33	msec
$X_{min}$ Rebound = -0.03 in	at time =	83	msec
$R_{max} = 1.06$ psi	at time =	33	msec
$R_{min} = -0.99$ psi	at time =	83	msec
Shortest Yield Line Distance to Determine		81.0	in
Equivalent Static Reactions			
<i>Peak Reaction (Vu) and Shear Information Based on Ult. Flexural Resistance</i>			
Vu at Support A =		Mullion	
		4,021	lb
Vu at Support B =		4,021	lb
Maximum Vu for Connection		4,021	lb
<i>Shear Capacity</i>		Mullion	
Shear Area: $A_v$		2.11	in <sup>2</sup>
Shear Capacity: $V_c$		36,684	lb
Shear Check		OK	

Next, check the intermediate mullions to make sure they are acceptable as well. By changing the span and spacing from the previous analysis, the intermediate mullions can be checked. Since these mullions are a shorter span, it is unlikely that they will control, but they should be checked. By using the longest horizontal mullion with the largest tributary area, the span is determined to be 3ft-11in and the spacing 5.125 ft.

After running the analysis, it was found that the intermediate mullions are also acceptable.

### B-7 EXAMPLE 6 – MASONRY SUPPORTING STRUCTURAL ELEMENT, STATIC DESIGN

**Problem Statement:** Statically design the supporting structural elements of an 8 inch thick, 10 ft high CMU wall with reinforcement of #4 bars at 32 inches. The window is 64" high by 36" wide. Assume that conventional construction standoff distances are available.

**Solution:** The first step is to determine the moment and shear strengths of the typical wall section. By using the equation below to determine the nominal moment strength ( $M_n$ ), it is determined to be 1,441 in-lbs per inch.

$$M_n = \frac{A_s F_y}{b} \left[ d - \frac{A_s F_y}{1.6 b f'_m} \right]$$

$$M_n = \frac{0.2(60,000)}{32} \left[ 4 - \frac{0.2(60,000)}{1.6(32)(1,500)} \right] = 1,441 \frac{\text{in} - \text{lbs}}{\text{in}}$$

Likewise the nominal shear strength ( $V_n$ ) can be found by using the equations below, which yields a shear capacity of 4,545 lb per foot.

$$V_n = V_m + V_s$$

$$V_m = \left[ 4 - 1.75 \left( \frac{M_u}{V_u d_v} \right) \right] A_n \sqrt{f'_m}$$

$$V_s = 0.5 \left( \frac{A_v}{s} \right) f_y d_v$$

Assume that the  $M_u/V_u d_v$  ratio is 1.0.  $A_n$  was found to be 46 in<sup>2</sup> per foot, based on an 8" CMU block with reinforcing at 32 inches.

$$V_m = [4 - 1.75(1)] A_n \sqrt{f'_m} \rightarrow (2.25) 46 \sqrt{1,500} = 4,009 \frac{\text{lbs}}{\text{ft}}$$

$$V_s = 0.5 \left( \frac{0.2}{32} \right) (60,000) (7.625) = 1,430 \text{ lbs} \rightarrow 536 \frac{\text{lbs}}{\text{ft}}$$

$$V_n = 4,009 + 536 = 4,545 \frac{\text{lbs}}{\text{ft}}$$

The next step is to determine the tributary area factor using Equation 1 from UFC 4-010-01 which is shown below.

$$C = \frac{a_{trib}}{a_{wall}} \geq 1$$

The window spacing is calculated by adding together half the reinforcing spacing, half the window width, and the distance from the reinforcing bar to the edge of the rough opening and multiplying the sum by the height.

$$a_{trib} = [(0.5 \cdot 32) + (0.5 \cdot 36) + (4)]120 = 4,680 \text{ in}^2$$

$$C = \frac{4,680}{32(120)} = 1.22$$

The wall area is 32 inches multiplied by the height. The tributary area factor is then calculated yielding a value of 1.22.

By applying this factor to the moment and shear nominal strengths, the supporting structural elements must have a nominal moment and shear capacity of 1,758 in-lbs per inch and 462 lbs per inch respectively.

$$M_{SSE} = C(M_{CW}) \rightarrow 1.22(1,441) = 1,758 \frac{\text{in} - \text{lbs}}{\text{in}}$$

$$V_{SSE} = C(V_{CW}) \rightarrow 1.22(4,545) = 5,545 \frac{\text{lbs}}{\text{ft}} \rightarrow 462 \frac{\text{lbs}}{\text{in}}$$

Try reducing the rebar spacing to 16 inches check the moment capacity using the same equations as above.

$$M_n = \frac{0.2(60,000)}{16} \left[ 4 - \frac{0.2(60,000)}{1.6(16)(1,500)} \right] = 2,766 > 1,758 \frac{\text{in} - \text{lbs}}{\text{in}} \text{ } \checkmark \text{ok}$$

Next, check the shear strength of the wall using the reduced rebar spacing.

$$V_m = [4 - 1.75(1)]A_n\sqrt{f'_m} \rightarrow (2.25)62\sqrt{1,500} = 5,403 \frac{\text{lbs}}{\text{ft}}$$

$$V_s = 0.5 \left( \frac{0.2}{16} \right) (60,000)(7.625) = 2,859 \text{ lbs} \rightarrow 2,145 \frac{\text{lbs}}{\text{ft}}$$

$$V_n = 5,403 + 2,145 = 7,548 > 5,545 \frac{lbs}{ft} \quad \checkmark ok$$

Since the moment and shear strengths are both greater than required, reduce the spacing to 16 inches.

## B-8 EXAMPLE 7 – STEEL STUD SUPPORTING STRUCTURAL ELEMENT, STATIC DESIGN

**Problem Statement:** Statically design the supporting structural elements of a 12 ft high steel stud wall using 600S162-54, 50 ksi studs spaced at 16 in on center. The window that the supporting structural elements will support is 64 in high by 38 in wide. Assume that conventional construction standoff distances are available.

**Solution:** The first step is to determine the moment and shear nominal strengths of the typical stud. By using the equation below and the section properties of the stud, the nominal moment strength can be calculated and was determined to be 47,650 in-lbs.

$$M_n = S_e F_y \rightarrow (0.953)(50,000) = 47,650 \text{ in} - \text{lbs}$$

Likewise the shear nominal strength ( $V_n$ ) can be found by using the following equations which gives a value of 4,231 lb.

$$V_n = A_w F_v$$

$$F_v = \frac{0.904 E K_v}{\left(\frac{h}{t}\right)^2} \rightarrow \frac{(0.904)(29,000,000)(5.34)}{\left(\frac{6}{0.0566}\right)^2} = 12,459 \text{ psi}$$

$$V_u = (1.0)(6)(0.0566)(12,459) = 4,231 \text{ lbs}$$

The next step is to determine the tributary area factor. The window spacing is calculated by adding together half the stud spacing and half the window width and multiplying the sum by the wall height.

$$[(0.5 \cdot 16) + (0.5 \cdot 38)]144 = 3,888 \text{ in}^2$$

$$C = \frac{3,888}{16(144)} = 1.7$$

The stud spacing is 16 inches. The tributary area factor can be calculated now by dividing 3,888 by the wall area, which gives a factor of 1.7.

By applying this factor to the moment and shear strengths, the supporting structural elements must have a moment and shear strength of 81,005 in-lbs 7,193 lbs respectively.

$$M_{SSE} = C(M_{CW}) \rightarrow 1.7(47,650) = 81,005 \text{ in} - \text{lbs}$$

$$V_{SSE} = C(V_{CW}) \rightarrow 1.7(4,231) = 7,193 \text{ lbs}$$

For the supporting structural elements the first trial will be with a doubled stud. The moment and shear of the doubled stud section should now be calculated to show that it is sufficient. The moment strength of the double stud is calculated to equal 95,300 in-lbs which is greater than the required 81,005 in-lbs so the moment strength is ok.

$$M_n = S_e F_y \rightarrow (1.906)(50,000) = 95,300 > 81,005 \quad \checkmark \text{ok}$$

Likewise the shear strength can be calculated and determined by multiplying the shear strength of one stud by 2 to get 8,462 lb which is greater than the required 7,193 lbs so the shear strength is ok.

$$V_n = (2.0)(4,231) = 8,462 > 7,193 \quad \checkmark \text{ok}$$

## B-9 EXAMPLE 8 – MASONRY SUPPORTING STRUCTURAL ELEMENT, DYNAMIC DESIGN

**Problem Statement:** Dynamically design the supporting structural elements of an 8 inch thick CMU wall with reinforcement of #4 bars at 32 in, which spans 10 ft. The threat is 88 lbs of TNT at 100 ft. The window that the supporting structural elements will support is 64" high by 38" wide. Assume a 15 psf façade.

**Solution:** Using SBEDS, the supporting structural elements can be designed. Most of the input values are straight forward, while there are a few that could be confusing at how they were derived.  $B_w$  is a ratio of the effective width resisting the blast over the loaded width. In the case of a supporting structural element, it is half the distance to the next reinforcement divided by the total tributary width, essentially the solid strip that exists. For this example, the  $B_w$  factor is shown below.

$$B_w = \frac{(16 + 4)}{(16 + 4 + 19)} \rightarrow \frac{20}{39} = 0.51$$

The assumed reinforcing spacing will not be the typical spacing used for the rest of the wall. The spacing should be the tributary width of the supporting structural element, and in this example it would be 39 inches.

Rather than using typical reinforcing bar size, try a #5 at the supports placed in the center of the block.

The percent of void space grouted is another tricky calculation. The easiest way to determine this value is to take the width of one cell of the masonry and divide it by the tributary width, assuming there are no other cells between reinforcing that are grouted full. For this example blocks are 16" wide, so a cell would be 8". Assuming that there are no other cells grouted in the 39" tributary width, the calculation would be 8 divided by 39 which gives a 20.5% void space grouted.

Figure B-17 Example 8 SBEDS Input

User Info: Fill in Yellow Cells, See Note Below for White Cells	
Span Length, L:	10 ft
Width Resisting Blast Load / Loaded Width; Bw	0.51 Note: $0 < Bw \leq 1.0$
BoundaryConditions:	One-Way: Simple-Simple, Uniformly Loaded
Response Type:	Flexural Only Type I Cross Section
Structural & Material Properties	
Total Wall Thickness, T:	8 in
<u>Reinforcing Steel Spacing</u> (See diagram in cell R37 for diagram of steel input terms)	
Bars Spanning Parallel to L, b <sub>c</sub> :	39 in
Not Used for One-Way Response	
<u>Reinforcing Steel Areas</u> *(Symmetric reinforcement assumed)	
Positive Moment Steel Parallel to L, AspL:	0.31 in <sup>2</sup>
Leave Input Blank for One-Way Response	
Negative Moment Steel Parallel to L, AsnL: *	0.31 in <sup>2</sup>
Leave Input Blank for One-Way Response	
<u>Distance of Cover to Center of Bars</u> : d <sub>c</sub> *(Symmetric reinforcement assumed)	
Non-Loaded Side Spanning Parallel to L:	4 in
Leave Input Blank for One-Way Response	
Loaded Side Spanning Parallel to L: *	4 in
Leave Input Blank for One-Way Response	
Masonry Type:	MediumWeight CMU
Percent of Void Spaced Grouted	20.51282051 %
Supported Weight, w:	10 psf
Masonry Compressive Strength, f <sub>m</sub> :	1,500 psi
Masonry Dynamic Compr. Increase Factor:	1.19
Wall Self-Weight, W:	46.47 psf
Masonry Dynamic Compr. Strength, f <sub>dm</sub> :	1,785 psi
Masonry Elastic Modulus, E <sub>m</sub> :	1,500,000 psi
Select Reinforcement:	A615, A616, A706 (All Gr. 60)
Reinf. Steel Yield Strength, f <sub>y</sub> :	60,000 psi
Reinf. Steel Ultimate Strength, f <sub>u</sub> :	90,000 psi
Average Increase Factor:	1.1
Dynamic Increase Factor:	1.17
Dynamic Reinf. Steel Yield Stress, f <sub>ys</sub> :	77,220 psi
Reinf. Steel Elastic Modulus, E <sub>s</sub> :	29000000 psi
Axial Load Input:	No Dynamic Axial Load
Static Axial Load; P': (Note: P>=0)	lb/in
Leave Input Blank for One-Way Response	
	ft

Figure B-18 Example 8 SBEDS Calculated Properties

Calculated Properties		
Rebound Positive H-Direction Moment Capacity, $M_{pH}$ :	0.00	lb-in/in
Inbound Positive H-Direction Moment Capacity, $M_{pH}$ :	0.00	lb-in/in
Inbound Positive H-Direction Reinforcement Ratio, $\rho_{pH}$ :	0.0000	
Rebound Negative H-Direction Moment Capacity, $M_{nH}$ :	0.00	lb-in/in
Inbound Negative H-Direction Moment Capacity, $M_{nH}$ :	0.00	lb-in/in
Inbound Negative H-Direction Reinforcement Ratio, $\rho_{nH}$ :	0.0000	
Rebound Positive L-Direction Moment Capacity, $M_{pL}$ :	2331.04	lb-in/in
Inbound Positive L-Direction Moment Capacity, $M_{pL}$ :	2331.04	lb-in/in
Inbound Positive L-Direction Reinforcement Ratio, $\rho_{pL}$ :	0.0020	
Rebound Negative L-Direction Moment Capacity, $M_{nL}$ :	0.00	lb-in/in
Inbound Negative L-Direction Moment Capacity, $M_{nL}$ :	0.00	lb-in/in
Inbound Negative L-Direction Reinforcement Ratio, $\rho_{nL}$ :	0.0000	
Inbound Reinforcement Ratio Check compared to $0.5\rho_{bal}$ :	Reinforcement OK	
Equiv. Stress Block Factor, $\beta_1$ :	0.85	
50% of Balanced Reinforcement Ratio, $0.5\rho_b$ :	0.0044	
Average Cover Depth for Moment of Inertia, $d_{c,avg}$ :	4.00	in
Average Moment of Inertia, $I_{avg}$ :	17.27	in <sup>4</sup> /in

The results box displays the majority of the output that is needed. Assuming a LLOP and the masonry wall being a primary member, the wall has a limiting response of 2 degrees rotation per PDC TR 06-08. Since the response is less than the limits and the shear is ok, the design is acceptable.

Figure B-19 Example 8 SBEDS Output

Results Summary			
$\theta_{max}$ =	1.76 deg.	Design Criteria:	LLOP/Primary
$\mu$ =	13.71	Response OK compared to input design criteria	
$X_{max}$ Inbound =	1.85 in	at time =	48.58 msec
$X_{min}$ Rebound =	0.00 in	at time =	0.00 msec
$R_{max}$ =	0.66 psi	at time =	48.58 msec
$R_{min}$ =	-0.62 psi	at time =	77.04 msec
Shortest Yield Line Distance to Determine $\theta$ :		60.0 in	
Equivalent Static Reactions*			
<i>Peak Reactions Based on Ultimate Flexural Resistance: <math>V_u</math></i>			
$V_u$ at right support*** =	39.6	lb/in	
$V_u$ at left support*** =	39.6	lb/in	
Maximum $V_u$ at distance d from support *** =	37.0	lb/in	
<i>Shear Capacity</i>			
Diagonal Shear Capacity: $V_{c,diag}$ =	132.3	lb/in	
Tensile steel depth for shear calculations, d:	4.0	in	
<i>Results based on Max Shear Region</i>			
At support:	Shear is OK****		
At distance d from support:	Shear is OK****		
<i>Required Stirrups based on Max Shear Region, <math>A_{v,req}</math> **, ****</i>			
Critical section @ support, $A_{v,req,s}$ :	0.0000	in <sup>2</sup> /in <sup>2</sup>	
Critical section at d, $A_{v,req,d}$ :	0.0000	in <sup>2</sup> /in <sup>2</sup>	

## B-10 EXAMPLE 9 – STEEL STUD SUPPORTING STRUCTURAL ELEMENT, DYNAMIC DESIGN

**Problem Statement:** Dynamically design the supporting structural elements of a steel stud wall using 600S162-54, 50 ksi studs spaced at 16 inches on center which span 10 ft. The window that the supporting structural elements will support is 64 in high by 38 in wide. Assume there is 15 psf on the wall due to the façade.

**Solution:** The first step is to determine all of the appropriate input for an SBEDS analysis. The stud spacing is not the typical stud spacing, but the tributary width of the supporting structural element, which in this example would be half of the typical spacing plus half of the window width, or 35 inches. Note the spacing is in feet and not inches.

Since the spacing is almost twice the typical, start with two studs backed together. Calculate the appropriate section properties of the built-up section and enter them as a user defined section.

Figure B-20 Example 9 SBEDS Input

User Info: Fill in Yellow Cells, See Note Below for White Cells	
Wall Span, L:	10 ft
Stud Spacing, B:	2.91666667 ft
Boundary Conditions:	Simple-Simple, Uniformly Loaded
Response Type:	Flexural
Structural & Material Properties	
Axis of Bending:	Shape:
Strong (X-X)	User Defined
Stud Self-Weight, w:	3.78 lb/ft
Moment of Inertia, I:	5.72 in <sup>4</sup>
Section Modulus, S:	1.906 in <sup>3</sup>
Web Thickness, tw:	0.1132 in
Depth, d:	6 in
Area, A:	1.11 in <sup>2</sup>
Web Punch-Outs	No Punch-Outs
Supported Weight (Exclusive of Structural Veneer Wall), w <sub>s</sub> :	15 psf
No Dynamic Axial Load	Static Axial Load, P <sub>s</sub> :
Leave Blank	0 lb/in
Steel Type:	A653, Gr. 50 (steel cold-formed)
Yield Strength, f <sub>y</sub> :	50,000 psi
Ultimate Strength, f <sub>u</sub> :	65,000 psi
Elastic Modulus, E:	29000000 psi
Static Strength Increase Factor:	1.21
Dynamic Increase Factor:	1.1
Dynamic Yield Stress, f <sub>dy</sub> :	66,550 psi
Veneer Wall Type:	No Wall/Non-Structural Veneer Wall
Calculated Properties	
Metal Stud Moment Capacity, M <sub>s</sub> :	126,844 lb-in
Veneer Wall Moment Capacity, M <sub>w</sub> :	lb-in/in
Veneer Wall Resistance from Axial Load Arching:	psi
Controlling Tension Membrane Force	0 lb



The results box displays the majority of the output that is needed. Assuming a LLOP and the stud wall is an infill wall, which means it is a secondary member, the wall has a limiting response of a ductility ratio of 2 per PDC TR 06-08. Since the response is less than this limit and the shear is ok, the design is acceptable.

Figure B-21 Example 9 SBEDS Output

<b>Results Summary</b>					
$\theta_{max} =$	1.47	deg.	Design Criteria:	LLOP/Secondary-NS	
$\mu =$	1.34		Response OK compared to input design criteria		
$X_{max}$ Inbound =	1.54	in	at time =	22.74	msec
$X_{min}$ Rebound =	-0.68	in	at time =	58.53	msec
$R_{max} =$	2.01	psi	at time =	14.24	msec
$R_{min} =$	-1.89	psi	at time =	58.53	msec
Shortest Yield Line Distance to Determine $\theta$ :				60.0 in	
<b>Equivalent Static Reactions*</b>					
<i>Peak Reactions Based on Ultimate Flexural Resistance of Metal Studs: <math>V_u</math></i>					
$V_{u,L} =$				4,228	lb
$V_{u,R} =$				4,228	lb
<i>Shear Capacity (of Metal Studs Only)</i>					
Shear Capacity: $V_s =$				19734	lb
<u>Results based on Max Shear Region</u>				Shear is OK	

**This Page Intentionally Left Blank**

## APPENDIX C DESIGN AND ANALYSIS COMPUTER PROGRAMS

### C-1 SBEDS-W

#### **Current Version:**

Version 1.0, 2012

#### **Distribution of SBEDS-W:**

SBEDS-W distribution authorized to U.S. Government agencies and their contractors: Critical Technology, March 2002 (U.S. citizenship required.)

#### **Technical Support:**

For technical support with the SBEDS program please contact:  
Protective Design Center  
CENWO-ED-S  
1616 Capitol Ave.  
Omaha, NE 68102-4901  
Email: PDC.Web@usace.army.mil

#### **Introduction:**

The SBEDS-W workbook is an Excel-based tool for design and analysis of windows and mullions subjected to dynamic loads that models components as equivalent single-degree-of-freedom (SDOF) systems. For purposes of SBEDS-W, a mullion directly supports the window, including storefront curtain walls. Backup structural members that do not directly support the window should be analyzed using SBEDS. Mullions can include thermal breaks and interior inserts.

SBEDS\_W is designed to run in a broad range of Windows® operating systems, including Windows 7, Vista and XP. General information on the distribution, development, and terms of use of SBEDS\_W is provided on the Readme worksheet in the SBEDS\_W workbook (the first worksheet in the workbook). SBEDS-W is distributed with the SBEDS workbook, which is a very similar workbook that is intended for blast-loaded non-window components. Typically, both SBEDS-W and SBEDS are installed into the same directory and used for blast design and analysis of window and non-window components, respectively.

SBEDS-W has been developed for the U.S. Army Corps of Engineers Protective Design Center (PDC) as a design tool to satisfy Department of Defense (DoD) antiterrorism standards. It may also be used for other types of blast design if appropriate blast load input, dynamic material properties, and response limits are used, which may vary from default values in SBEDS-W. SBEDS-W uses equivalent single-degree-of-freedom systems to analyze the dynamic response of single pane windows and mullions. It uses a two-degree-of-freedom (2DOF) methodology to analyze insulated glazing units (IGU (i.e. double pane windows) that consists of SDOF models for each pane that are both loaded by the pressure from volume change of the gap between panes as they move relative to each other. All windows are analyzed assuming rigid supports, which is often not the case in actual construction. However, window frame movement usually limits

the dynamic response of the glass so that this assumption is generally conservative. SBEDS-W is only intended for windows supported on four sides or two opposite sides (i.e. butt glazed).

SBEDS-W can be used to design or analyze windows with monolithic, filmed, and laminated glazing of various glass types, as well as windows with polycarbonate glazing. The windows can consist of one pane, or two glass panes in an IGU (insulated glass unit) configuration. Laminated windows can only include one glazing type. Also, laminated glass panes with multiple laminate interlayers are simplistically modeled with a single interlayer equal to the sum of all the interlayers and two panes of glass with a total thickness equal to the sum of all pane thicknesses. SBEDS-W uses a semi-empirical method for analyzing the response of laminated windows to blast loads. This method was developed specifically for windows with PVB laminate interlayer and is not applicable to other types of interlayer materials.

SBEDS-W will only calculate blast loads for the basic case of an external (i.e. outside the building) surface burst explosion of high explosive that is not affected by any reflecting surfaces from nearby adjacent buildings, etc. High explosives other than TNT can be input and SBEDS-W will convert them to an equivalent amount of TNT. Other approaches such as a ray-tracing code or computational fluid dynamics code can be used to calculate blast loads from more complex cases involving multiple shockwaves reflections, confined (internal) explosions, etc., and these loads can be saved into a text file and read into SBEDS-W. Simplified design blast loads, such as those commonly specified for design of many U.S. government buildings, can be input directly onto the *Input* sheet with a maximum of eight pressure-time pairs.

**Intended Audience:**

The SBEDS-W workbook is intended for engineers experienced in structural engineering, dynamics, and blast design. It is not for the non-structural engineer. SBEDS-W is suited for preliminary design or final design when used by a skilled engineer. It will aid the engineer in design of window members, but the actual design of members and connections is the full responsibility of the engineer.

**C-2 WINGARD PE**

**Current version:**

Version 5.5.1, 2008.

**Distribution of WINGARD:**

WINGARD is not widely distributed. The program is generally reserved for employees of GSA; other U.S. government agencies; established U.S. blast, structural, and security consulting firms; or other U.S. firms involved with protective glazing. All users are highly encouraged to thoroughly read the technical and user manuals prior to using this program. To obtain a copy of WINGARD, contact the Building Security Technology Program team at oca.bstp@gsa.gov and provide your name, address, phone number, organization, and a description of your intended use of the software.

**Technical Support:**

For technical support with the WINGARD program please contact:  
Building Security Technology Program (BSTP) Team  
oca.bst@gsa.gov

or:

Applied Research Associates, Inc.  
wingardpesupport@ara.com

**Introduction:**

WINDow Glazing Analysis Response and Design (WINGARD) was developed for the General Services Administration by Applied Research Associates (ARA). The goal was to develop a simple but accurate mode of the response of windows to the effects of an explosion. The program, which has become the national standard for analysis of glazing for blast loadings, calculates and graphically displays the response of window systems subjected to blast loads. WINGARD is an analysis tool that accepts user input of window system properties and explosion characteristics, and then calculates the performance of the window system when subjected to defined blast loads. The WINGARD software is available in three versions: WINGARD PE (Professional Edition), LE (Limited Edition), and MP (Multi-Pane).

**Intended Audience:**

The users of WINGARD will typically range from an engineer or architect with rudimentary blast experience to the engineer or architect with explosive effects expertise. This tool is written for the technical practitioner. WINGARD is suited for preliminary design or final design when used by a skilled user. WINGARD will aid the in design of the window with the understanding that the actual design and member connections are the full responsibility of the designer.

**C-3 SBEDS**

**Current version:**

Version 4.1a, 2009.

**Distribution of SBEDS:**

SBEDS is approved for public release; distribution is unlimited.

**Technical Support:**

For technical support with the SBEDS program please contact:  
Protective Design Center  
CENWO-ED-S  
1616 Capitol Ave.  
Omaha, NE 68102-4901  
Email: PDC.Web@usace.army.mil

**Introduction:**

SBEDS is an Excel© based tool for the design and analysis of structural components subjected to dynamic loads, such as airblast from explosives, using single-degree-of-freedom (SDOF) methodology. SBEDS is based on Army TM 5-1300 (also designated as NAVFAC P-397 and AFR 88-22) and UFC 3-340-01, but draws on other sources where improved methodologies are available.

The user can choose from twelve common structural components and then enter readily available parameters related to material properties and geometry, allowing the workbook to calculate the SDOF properties or directly entering the SDOF properties. Masonry, reinforced concrete, steel, cold-formed metal, and wood components are included. Standard materials and members can be selected from dropdown menus to ease input. Various support conditions can be selected for one-way and two-way members. A flexure resistance function is used with compression membrane and/or tension membrane contributions where applicable and selected by the user. Either uniformly distributed or concentrated loads are accommodated.

Three options for entering the load to drive the SDOF system are available: the user can enter a piecewise linear load consisting of up to eight segments; an ASCII file containing up to 2900 time-pressure pairs can be specified and the workbook will read in the load; or a uniform distributed airblast from detonation of a high explosive (HE) hemispherical surface burst can be generated by the workbook for a specified charge weight and standoff distance. When using the HE load generation option, the user can specify whether to include the negative phase of the pressure history or not, reflected or side-on pressure, angle of incidence for calculation of reflected pressure, and distance to free edges of the structure for adjusting the loading for clearing effects.

Numeric integration of the equation of motion is accomplished using a constant velocity method with user-specified dampening considered. Maximum and minimum displacements, maximum support rotation, ductility, resistance, and peak reactions are reported. Additionally, histories for displacement, resistance, reactions, and load are provided. Shear capacity of the component is evaluated and reported. For concrete and masonry elements required areas of shear steel are also calculated and reported.

SBEDS includes the option of generating pressure-impulse (P-i) diagrams and charge weight-standoff (CW-S) diagrams for up to four levels of response defined by support rotations or ductility ratios for the specified component. These types of diagrams are valuable when performing assessments or repetitive design. The user specifies whether the CW-S diagrams are for either fully reflected or side-on loading from hemispherical HE surface burst and whether to consider the negative phase in the calculations.

**Intended Audience:**

SBEDS was developed for structural engineers with solid knowledge of structural engineering, dynamics and blast effects. This tool is not for the non-engineer. SBEDS is suited for preliminary design or final design when used by a skilled engineer. SBEDS will aid the engineer in design of the member, but the actual design of members and connections is the full responsibility of the engineer.