

What this symbol means?

- OUTSIDE PROCESSING
- NOTE: 1) INDUCTION HARDEN TO .06 MINIMUM CASE DEPTH TO Rc 42-46
- 2) ELECTROPLATE TO ASTM B633-98 TYPE II, YELLOW DICHRONATE, SC-1 THICKNESS: 0.00019 (+0.00012/-0)
- 3) BAKE AFTER PLATING TO ASTM B850-98

3	97611717	1	ROUND
2	97012548	1	FLAT
1	2088	1	JAM NUT, 1 3/4-5 UNC 2B
ITEM	PART NO	QTY	DESCRIPTION

DRAWING IN INCHES
UNLESS OTHERWISE SPECIFIED:

UNSPECIFIED TOLERANCES		
DECIMALS	INCH	mm
X.X	±.1	±3.0

THIRD ANGLE PROJECTION

DESIGNER:

DRAWN DATE:

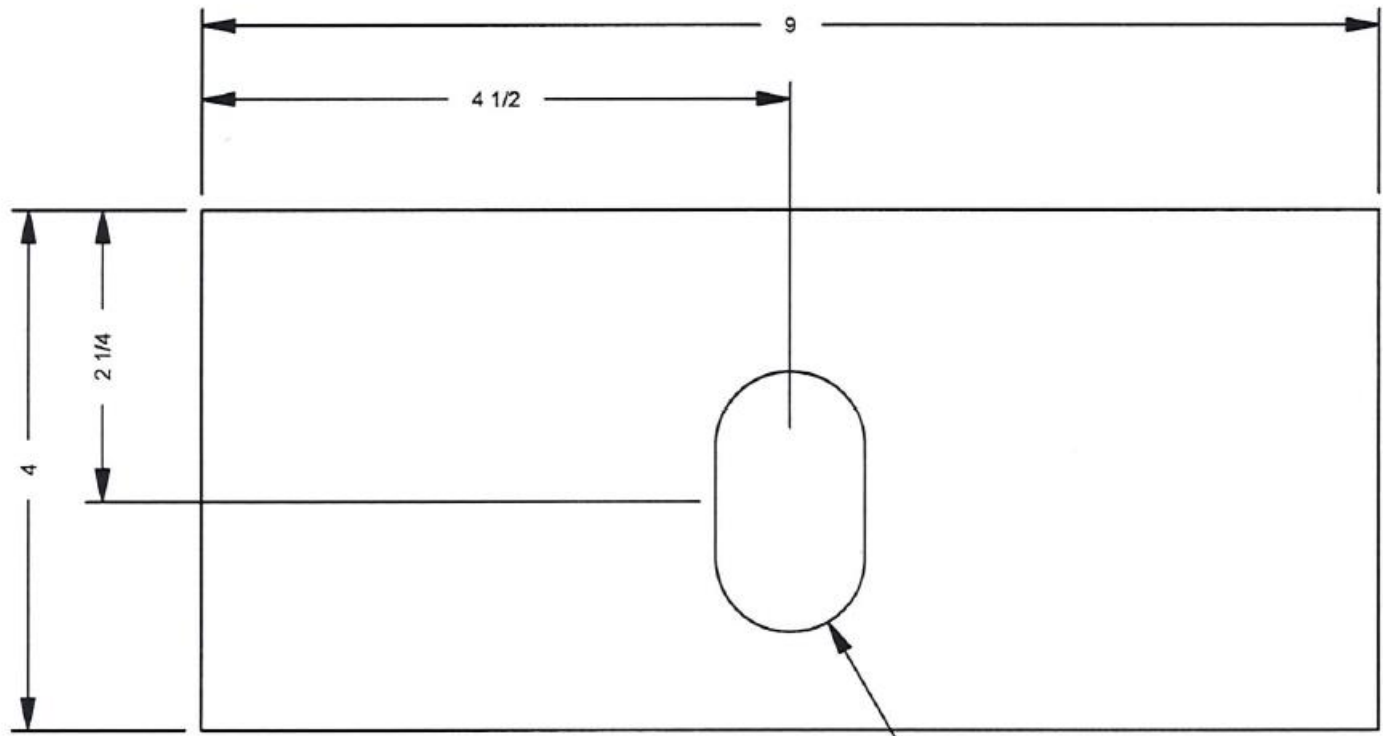

Ø1 1/8 x 2 OBR

OBR short for?