

# AN467

## NXP's 51LPC-Microcontrollers & Triacs easily connected

Rev. 2 — 10 January 2013

Application note

### Document information

Info	Content
<b>Keywords</b>	51LPC, 80C51, three-quadrant triac
<b>Abstract</b>	This application note describes the easy connection of NXP LPC microcontrollers and three-quadrant (Hi-Com) triacs to control any resistive or inductive load at mains voltage. A one-for-all control method is presented that uses an innovative, patented, current zero-crossing detection method without need for a shunt resistor in the load current line.



**Revision history**

Rev	Date	Description
2	20130110	Modifications: <ul style="list-style-type: none"><li>• The format of this application note has been redesigned to comply with the new identity guidelines of NXP Semiconductors.</li><li>• Legal texts have been adapted to the new company name where appropriate.</li><li>• Corrected Fig 17 and Fig 18.</li></ul>
1	20011206	<ul style="list-style-type: none"><li>• Initial version.</li></ul>

**Contact information**

For more information, please visit: <http://www.nxp.com>

For sales office addresses, please send an email to: [salesaddresses@nxp.com](mailto:salesaddresses@nxp.com)

## 1. Introduction

---

This Application Note describes the easy connection of NXP LPC microcontrollers and three-quadrant (Hi-Com) triacs to control any resistive or inductive load at mains voltage. A one-for-all control method is presented that uses an innovative, patented, current zero-cross detection method without the need for a shunt resistor in the load current line.

The NXP 51LPC family of 80C51-based microcontrollers provides low system cost and low power consumption. This new family targets low power applications where overall system cost is critical. With embedded features such as brownout detection, analog functions and an on-chip RC oscillator, the 51LPC series of microcontrollers requires the minimum of external components. These features, combined with an improved C51 architecture, create more options in designing highly integrated, low cost, low power control circuits.

This Application Note covers:

- Phase control and switching of resistive and inductive loads
- Detection of the zero-crossings of the load voltage and load current
- Triacs and their interface to the LPC
- Derivation of the power supply from the AC line

The solutions introduced in this note can be realized with the P87LPC762/4 and their on-chip RC oscillator and comparators, or other LPCs with additional on-chip functionality such as PWM, ADC and DAC.

Typical applications are control of motors (AC+DC), valves, pumps, lamps etc. in white goods, HVAC, power tools, appliances and industrial control.

The block diagrams in [Fig 1](#) and [Fig 2](#) show an overview of the applications. The circuit is powered directly from the mains supply. The timing for the phase control is derived from the mains voltage zero-crossings (see [Fig 1](#)) or the load current zero-crossings (see [Fig 2](#)) depending on the application. The control blocks calculate the trigger moment and the LPC can directly sink the gate current for many triacs. The individual blocks are discussed in the different chapters of this Application Note.

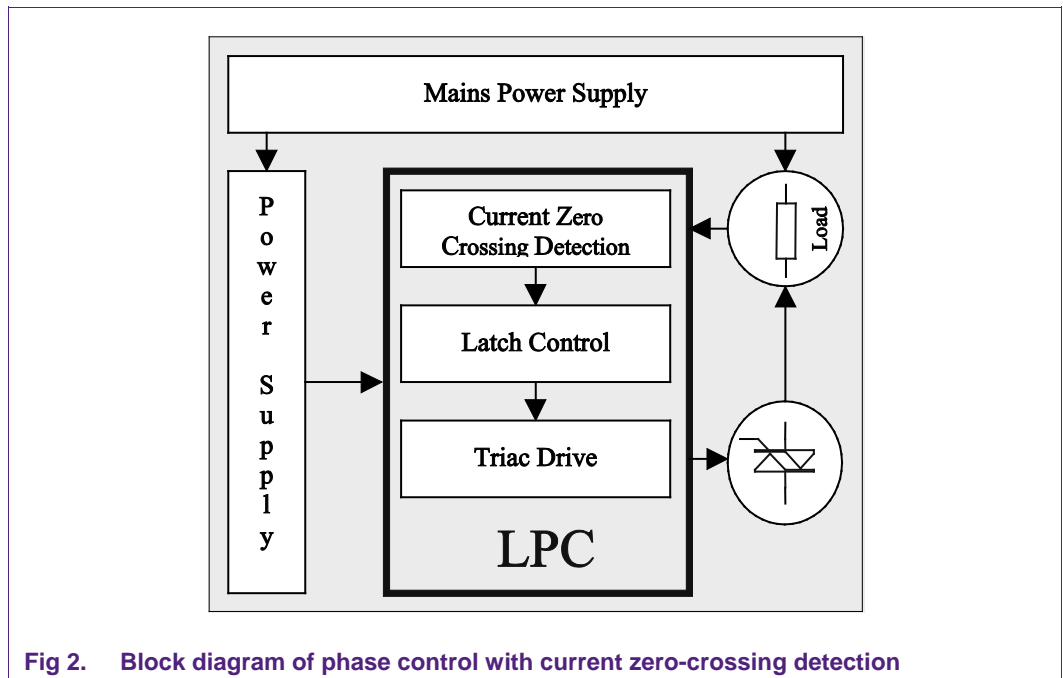
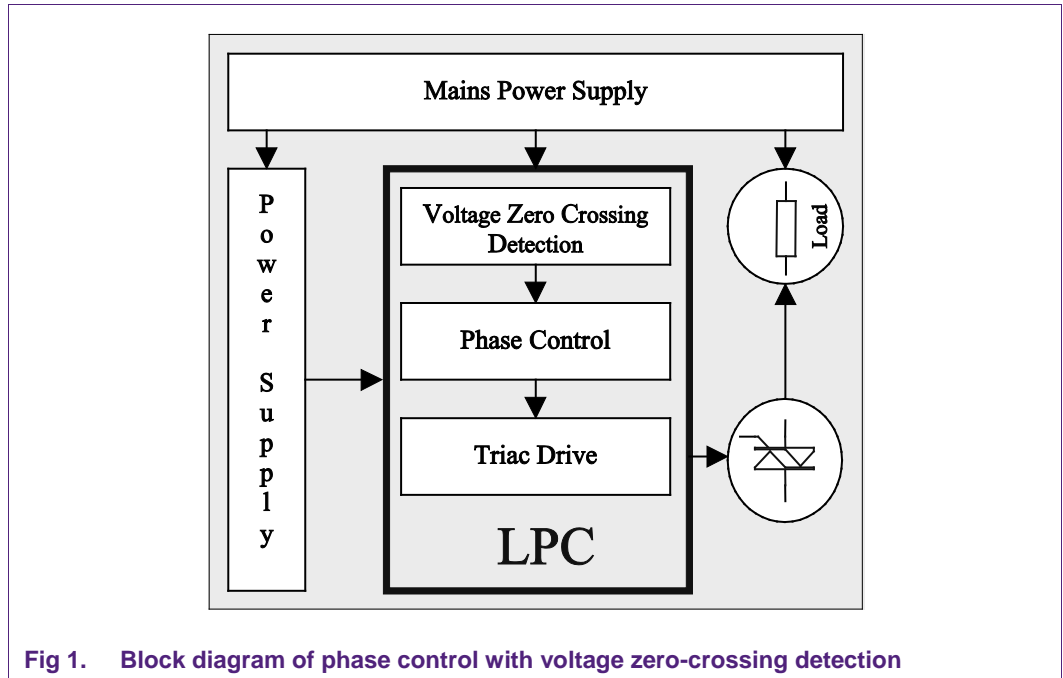

## 2. Phase control and switching

A triac is the optimum device for solid state control of AC loads at low frequency, i.e. mains frequency. Control can take the form of simple on-off switching as required for electronic thermostats or any simple load where only full power must be applied. It can also take the form of variable power control by the use of “phase control”, where the AC sine wave is chopped by delaying the triac trigger in each half cycle of the mains.

### 2.1 Phase control

All functions of a phase control application can be performed with an LPC. The LPC can detect the beginning of a half wave by detecting the voltage zero crossing, after which it can calculate the phase angle, time the phase delay and trigger the triac. Voltage zero crossing detection and triac driving are discussed in separate chapters.

The phase delay can be timed with the internal timers of the LPC. After detecting a zero crossing, the LPC reloads the timer with a value proportional to the desired phase angle and starts the timer. When the timer expires, the triac is triggered and the load current flows (see below). All this can be achieved by being completely interrupt-driven.

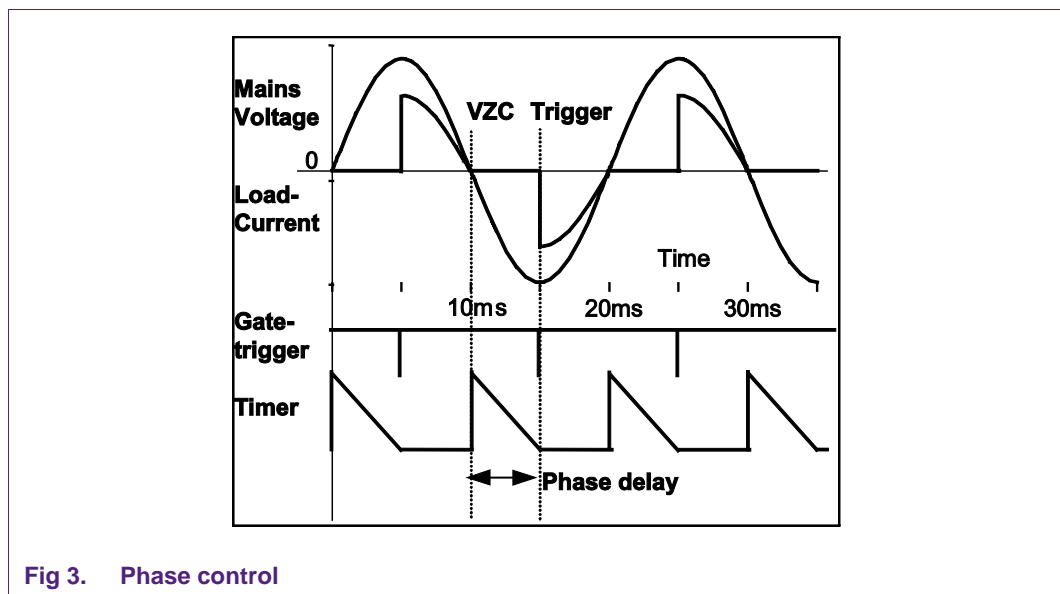

Fig 3. Phase control

Another possibility is to detect one voltage zero crossing per cycle (say a falling edge). The timing is performed as described above for the first half wave. However, at the trigger event the timer is reloaded with a value equivalent to the duration of one half cycle (e.g. 10 ms at 50 Hz), after which the triac is triggered. This takes care of the alternate half cycles where voltage zero cross detection is not performed.

## 2.2 Switching

In applications where only full power is delivered to the load, continuous load current without any discontinuities must be guaranteed to avoid possible Electro Magnetic Interference problems. This is difficult for inductive loads because current and voltage are not in phase. The triac will turn off (“commutate”) at the current zero crossing, so voltage zero crossing detection is therefore of no use. The triac must be retriggered when the current drops to zero at the current zero crossing as shown in [Fig 4](#). How to detect the current zero crossing is described in a later chapter.

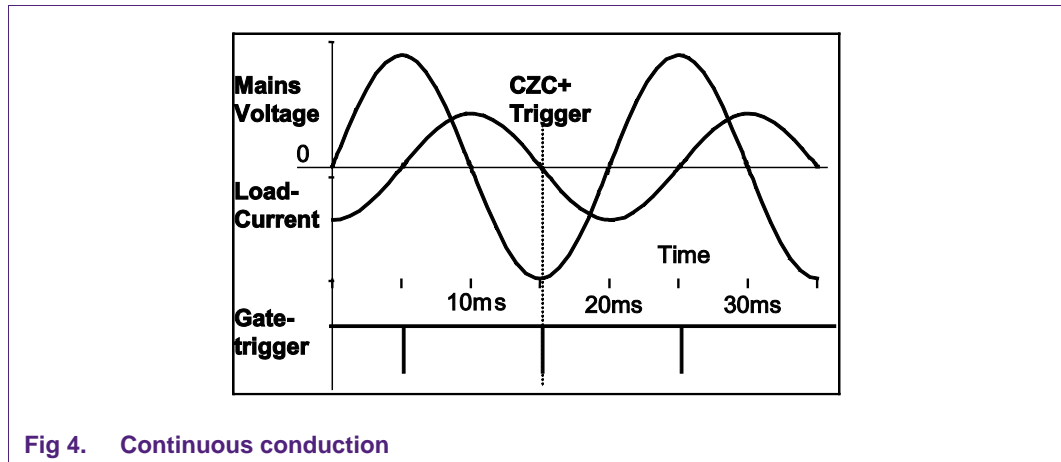

Fig 4. Continuous conduction

When power is first applied to the circuit, there is no load current, so current zero crossing detection is not possible. The initial trigger pulse should therefore be applied at a voltage zero crossing. This avoids an uncontrolled start-up at an unspecified point in the mains cycle. It ensures low EMI and controlled, predefined ramp-up of load current from the beginning of a mains cycle.

## 3. Triac choice

Three-quadrant triacs are specified exclusively in this Application Note for their vastly superior immunity to commutation failure / loss of control compared to their more traditional four-quadrant alternatives. Three-quadrant triacs are the automatic first choice for any application.

Three-quadrant triacs do not trigger in the 3+ quadrant (T2-, G+), so they cannot be driven by a gate drive circuit that sources current. This does not matter for the vast majority of IC drive circuits, which are configured to sink current. This is because they can sink more current, more easily than they can source current. This certainly holds true for microcontrollers and logic ICs.

Negative gate current results in triac operation in the 1- and 3- quadrants. Four-quadrant triacs only become necessary if the drive circuit sources gate current. Positive gate current results in triac operation in the 1+ and 3+ quadrants. [Fig 5](#) shows the triac triggering quadrants and nomenclature.

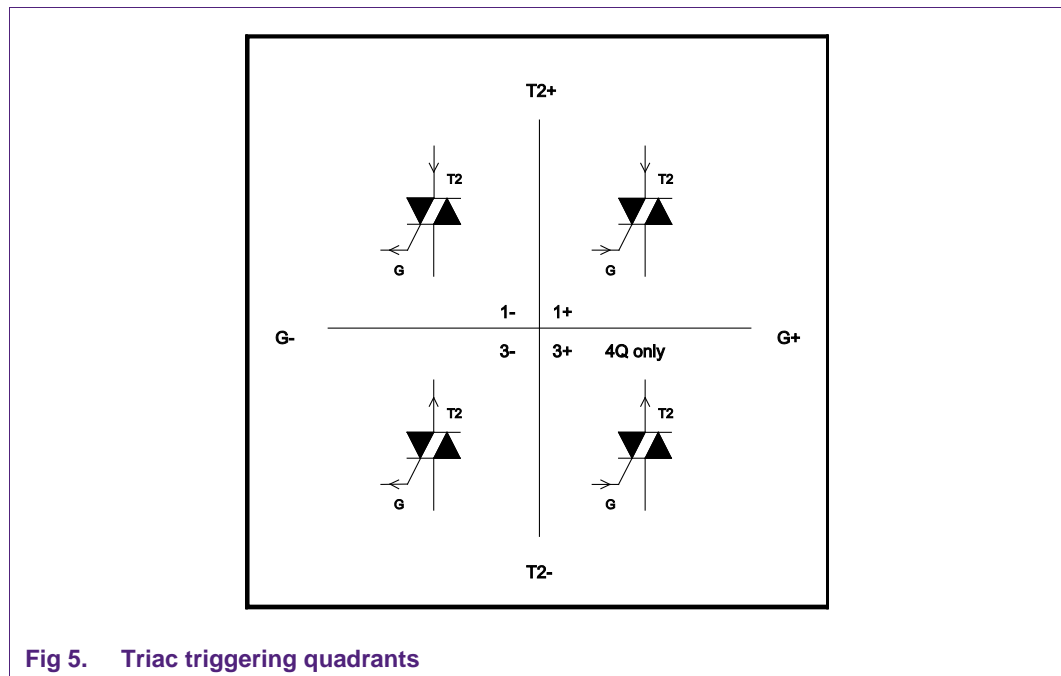

Fig 5. Triac triggering quadrants

All application requirements are covered by NXP Semiconductors' range of three-quadrant triacs, which are available in surface mount (SOT223, DPAK and D<sup>2</sup>PAK), non-isolated (TO220) and isolated (SOT186A) packages. Gate sensitivities range through D-type ( $I_{GT} = 5$  mA), E-type ( $I_{GT} = 10$  mA), F-type ( $I_{GT} = 25$  mA), Ctype ( $I_{GT} = 35$  mA) and B-type ( $I_{GT} = 50$  mA). The best commutation performance (immunity to loss of control) is offered by the least sensitive Btypes.

For further details please refer to the references.

## 4. Triac driving

The microcontroller supply voltage (+5 V) and the Main Terminal 1 (MT1) of the triac are connected to the power line. The LPC drives the gate of the triac with a negative pulse from an output port via a series current-limiting resistor. The preferred negative gate current results in triac operation in the 1- and 3- quadrants. This avoids the 3+ quadrant, where three-quadrant triacs do not trigger.

The LPC port is in push-pull mode, which means that the output FETs remain in the low impedance state at all times while they hold the output at (inactive) logic 1 or (active) logic 0. This ensures that any voltages fed back into the LPC port from the triac gate are clamped safely to  $V_{CC}$  or GND via devices that are capable of conducting the clamp current. The more vulnerable ESD protection diodes are not therefore required to conduct unspecified currents fed back from the triac gate.

To turn a triac on, a gate current  $\geq$  the gate trigger current  $I_{GT}$  must be applied until the load current is  $\geq$  the latching current  $I_L$ . For an NXP three quadrant D-type triac (e.g. the 16A-rated BTA216-600D) the  $I_{GT}$  is only 5 mA. The NXP LPC can easily drive this current with a single port pin thanks to its high drive capability of  $I_{OL} = 20$  mA. For the least sensitive, highest commutation B-type triacs (e.g. BTA216-600B), three LPC output ports can be paralleled to meet the 50 mA  $I_{GT}$  requirement. Up to 4 LPC port pins can be combined as long as the maximum drive capabilities of  $I_{OL} = 20$  mA per pin and 80 mA for all outputs is not exceeded (see [Fig 6](#)).

The ports have controlled slew rates, so the current ramps up in approximately 10 ns, distributed evenly on all three ports.

To drive very insensitive triacs, or several triacs exceeding the maximum current for all outputs with one LPC, the LPC can use one (or more) external transistor(s) (see [Fig 7](#)). Triac operation is still in quadrants 1- and 3-.

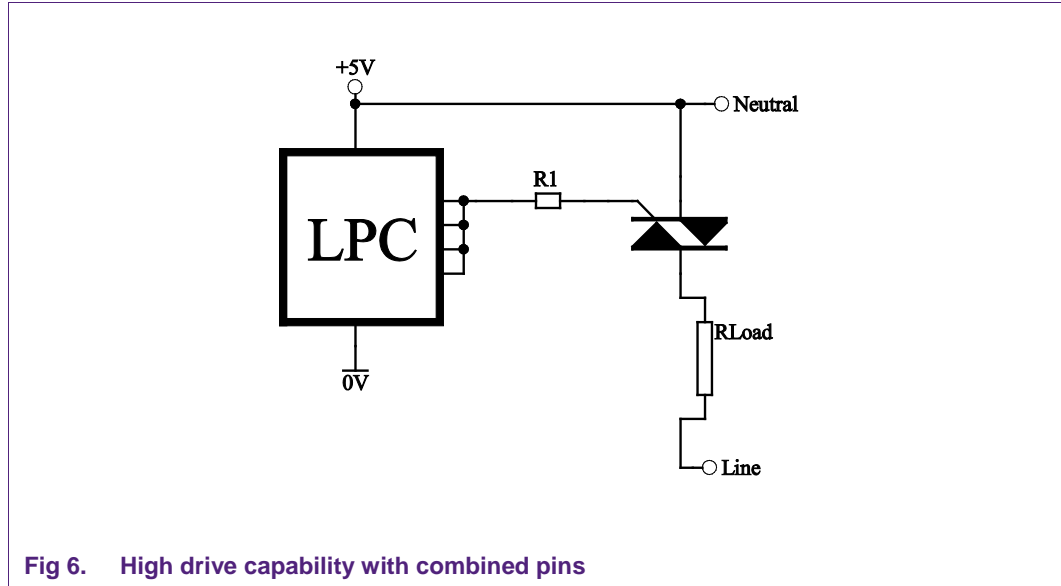

Fig 6. High drive capability with combined pins

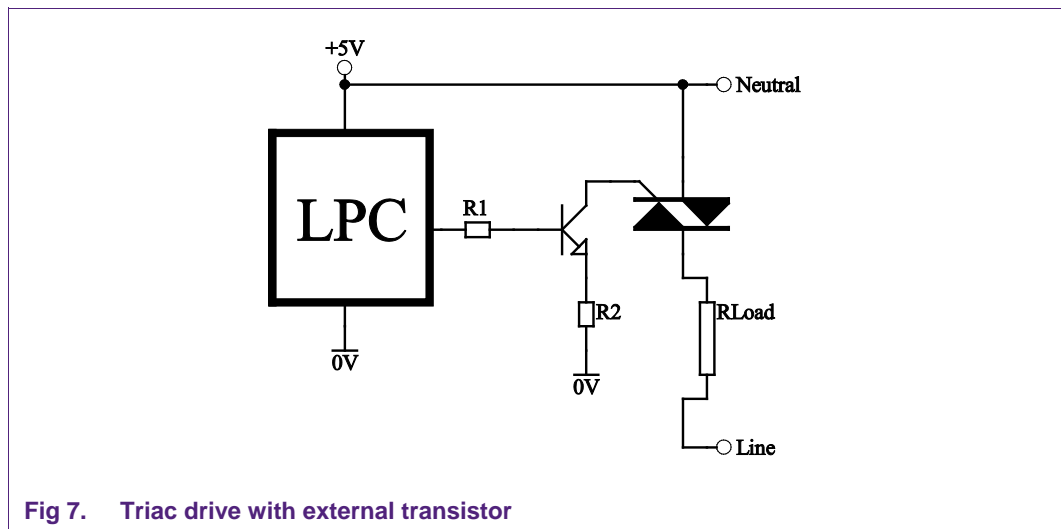

Fig 7. Triac drive with external transistor



## 5. Zero-crossing detection

For low EMI, safe operation or phase control, it is necessary to trigger the triac at zero current crossing or at a particular phase angle. For resistive loads, the current and voltage zero crossings are coincident; for inductive loads, the current lags behind the voltage. The nature of the load will dictate whether triac triggering must be based on voltage zero crossing or current zero crossing. Following are some methods to detect voltage or current zero and zero crossings.

### 5.1 Voltage zero crossing - simple input

The easiest solution for voltage zero crossing detection is to measure the voltage polarity swing over the mains power supply. The positive supply +5 V of the LPC is connected to line (or neutral), while neutral (or line) is connected to any I/O port via a current-limiting resistor. The voltage at the I/O port is clamped to 0 V and +5 V by the internal clamping diodes of the microcontroller (see Fig 8). The microcontroller can read the port input state and can detect the zero crossing when that state changes from 1 to 0 or 0 to 1.

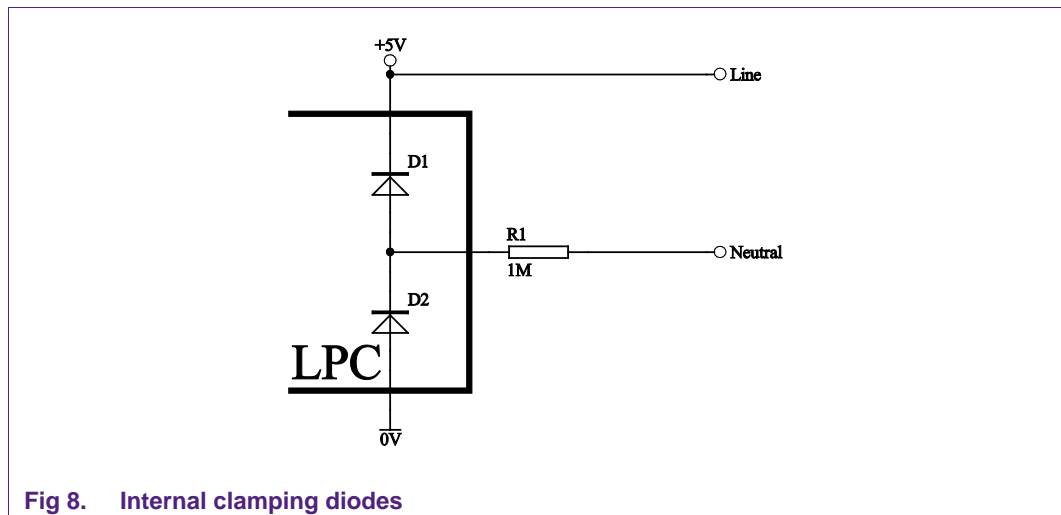

Fig 8. Internal clamping diodes

The switching point depends on the I/O-pin mode (ttl or Schmitt trigger). The delay between zero crossing and detection depends also on the slew rate of the power line (e.g. 230 V or 110 V systems). This must be taken into account. The advantage of this circuit is its simplicity and low cost, because only one extra resistor is needed (note high voltage rating required), and any LPC pin can be used.

The LPC has two interrupt pins and a keyboard interrupt feature on port 0 with external interrupt capability. When these external interrupt inputs are used the LPC can generate an interrupt on the falling edge of the line voltage and the microcontroller does not have to poll the input register. For more accurate zero crossing detection with no hysteresis or offset that is more symmetrical about zero, or for interrupts on both edges, see the following chapters that describe the use of the internal comparators.

5.2 Voltage zero crossing - comparator

The LPC's internal comparator is ideal for zero crossing detection. In the set-up in Fig 9 the positive input of the comparator is connected to the power line via a high-voltage-rated current limiting resistor; the pin voltage is limited by the internal clamping diodes. The negative input is connected to an external or to the internal reference voltage. The comparator output toggles with the voltage zero crossing. Either the LPC can poll the comparator output, or the comparator can generate interrupts. This allows the LPC to receive interrupts on rising and falling edges.

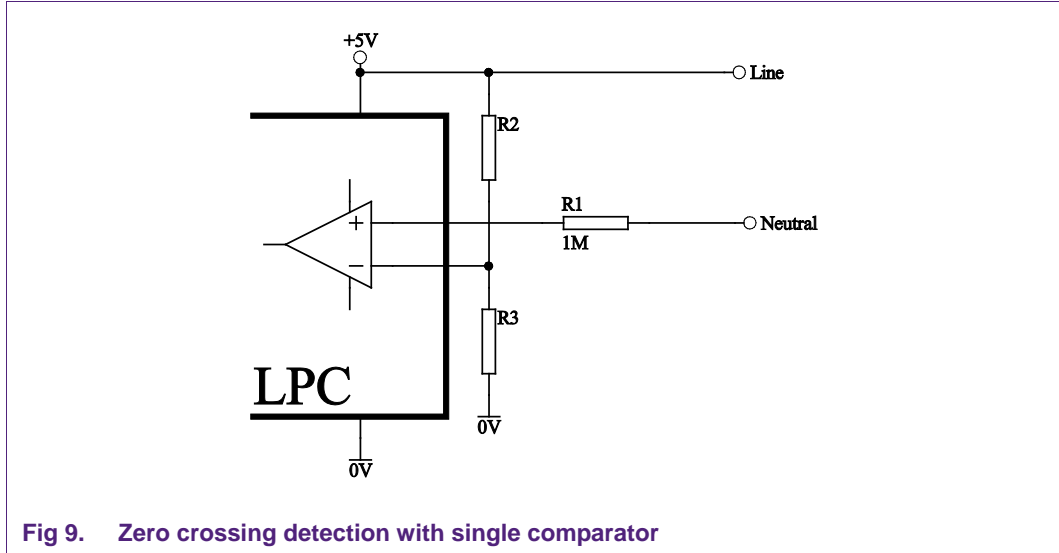

Fig 9. Zero crossing detection with single comparator

The set-up of Fig 9 has a small offset from the real zero crossing resulting from the difference between +5 V (line) and the reference voltage. High precision zero crossing detection becomes possible if this DC offset is removed by AC coupling the mains voltage signal, as shown in Fig 10.

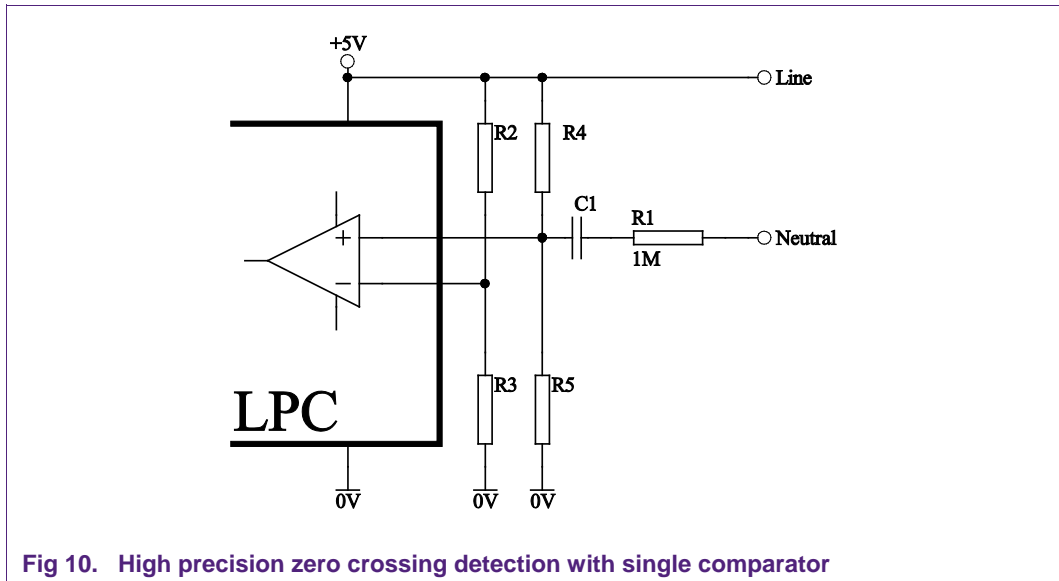
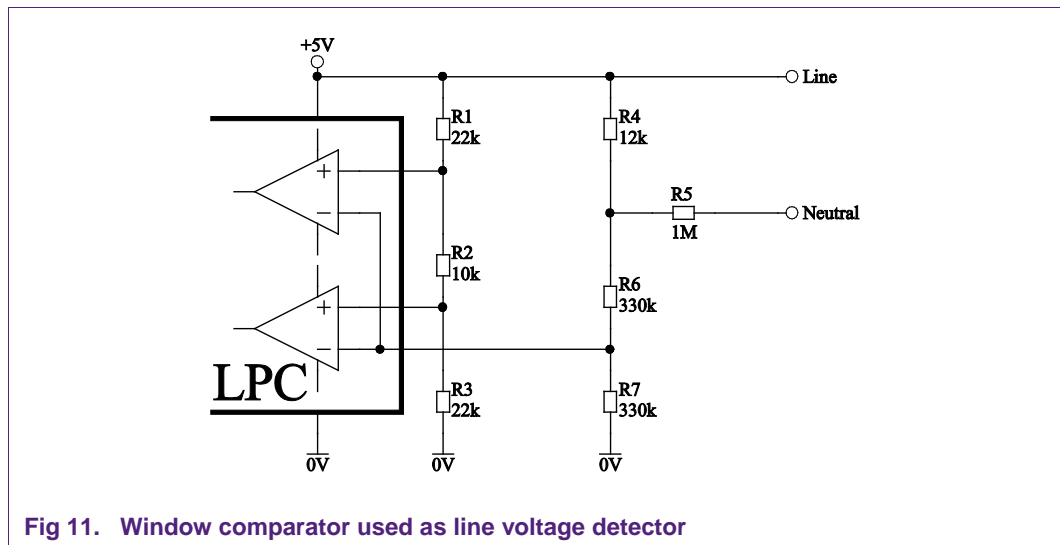

Fig 10. High precision zero crossing detection with single comparator

When the voltage dividers R2/R3 and R4/R5 are matched, the comparator toggles exactly at the zero crossing point. This circuit is symmetrical for both half-cycles and is also suitable for low voltage systems (e.g. 12 V AC), where any error in zero crossing detection could quickly form a relatively large proportion of the total supply voltage.

### 5.3 Voltage zero crossing – window comparator

It is often useful to be aware of a zero crossing in advance: one example being so that a triac can be retriggered before it commutates (drops out of conduction) for continuous conduction applications. In this case, a window comparator can detect when the line voltage is under a certain level so that the triac can be retriggered (see [Fig 11](#)).



The resistor network (R4-R7) shapes the line voltage around the voltage window of R1-R3, so that the zero crossing point is roughly in the middle of this window and one comparator output toggles when the voltage enters this window. The output change can be detected via interrupt or polling to cause actions like triggering a triac.

### 5.4 Current zero crossing – window comparator

The current zero crossing (czc) is critical and is usually the one to monitor because this is when the triac commutates. It is particularly relevant for any non-resistive load when the czc will not correspond with the voltage zero crossing (vzc). However, we know that it is not as easy to monitor czc as it is to monitor vzc because, conventionally, a shunt resistor is required in series with the load. This has the disadvantages of disrupting the load circuit and dissipating power. Amplification and level shifting are usually required to interface the voltage developed across this component to the microcontroller. This requires, at the very least, an additional operational amplifier plus associated components.

A much better method of detecting imminent triac commutation at czc is to monitor the triac gate voltage  $V_G$  with respect to T1.  $V_{G-T1}$  gives a clue to when the triac is approaching commutation because it passes through zero at the czc. Depending on the load current and triac characteristics,  $V_{G-T1}$  can be as low as 0.1 V or greater than 1.2 V. In the circuit of [Fig 12](#), this voltage is monitored using a window comparator.

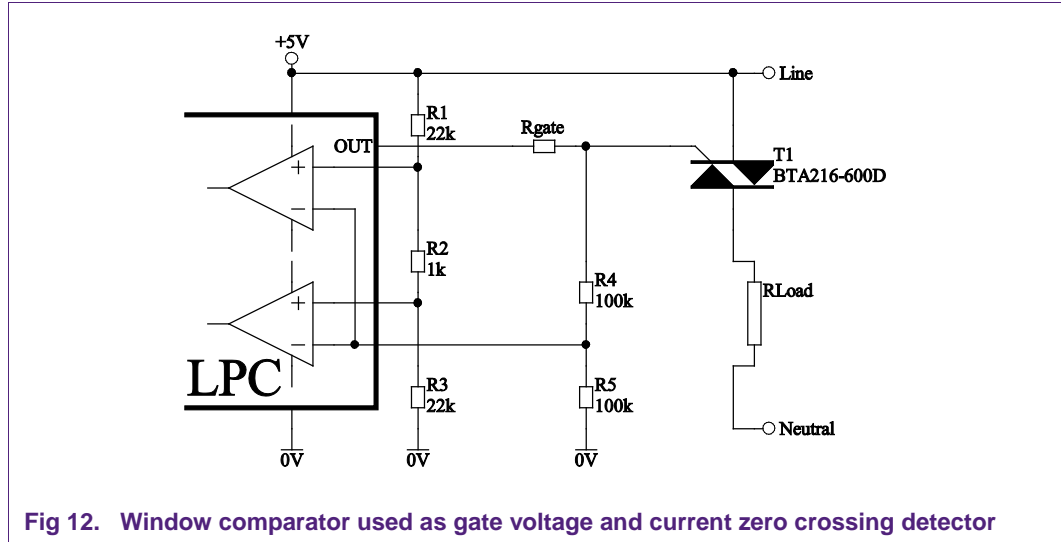

Fig 12. Window comparator used as gate voltage and current zero crossing detector

$V_{G-T1}$  can be positive or negative with respect to the line voltage and is dependent upon the direction of the load current. This means that  $V_{G-T1}$  is positive or negative with respect to  $V_{CC}$  (+5 V). Therefore, before it can be monitored by the LPC it must be divided in half by the voltage divider R4 and R5 to reduce it below  $V_{CC}$  and to bring it within the operation range of the comparator. R1, R2 and R3 create a voltage window around the zero crossing point.

Fig 13 shows the oscillogram of an application that uses the circuit in Fig 12. The load is a 44 W fan motor. Channel 1 shows triac gate voltage (divided by 2), channel 2 shows LPC output port voltage, channel 3 shows mains voltage and channel 4 shows lagging load current. The phase delay of the current is about 2.4 ms, or  $43^\circ$  (50 Hz system).

The LPC detects the current zero crossing, via  $V_{G-T1}$ , and triggers the triac repeatedly until  $V_{G-T1}$  remains at a high level that is outside the detection window. Only then is the load current above the triac's latching current  $I_L$  and the triac latched ON. This control method applies the minimum gate current that guarantees continuous, uninterrupted load current for any load. This assured triac triggering is achieved with the minimum current burden on the LPC's power supply. The gate drive and  $V_{G-T1}$  detection are mutually exclusive:  $V_{G-T1}$  can only be monitored when the gate is not being driven by the LPC.

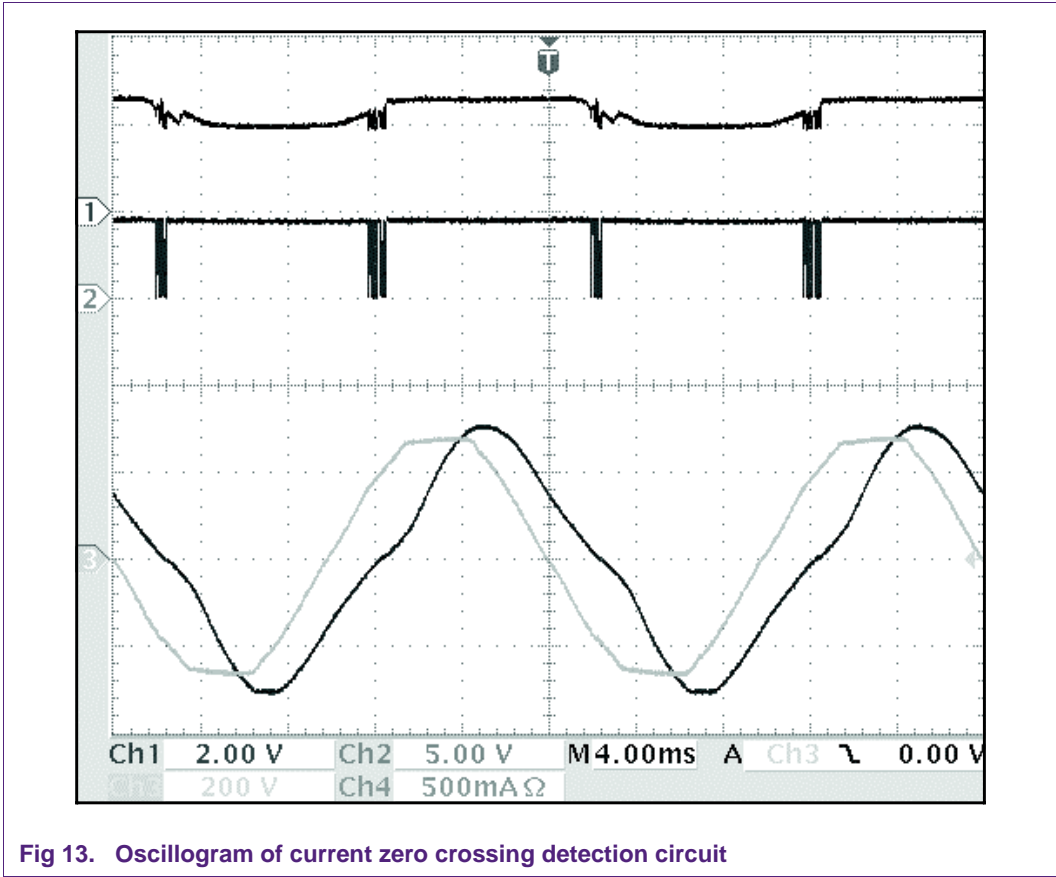

Fig 13. Oscillogram of current zero crossing detection circuit

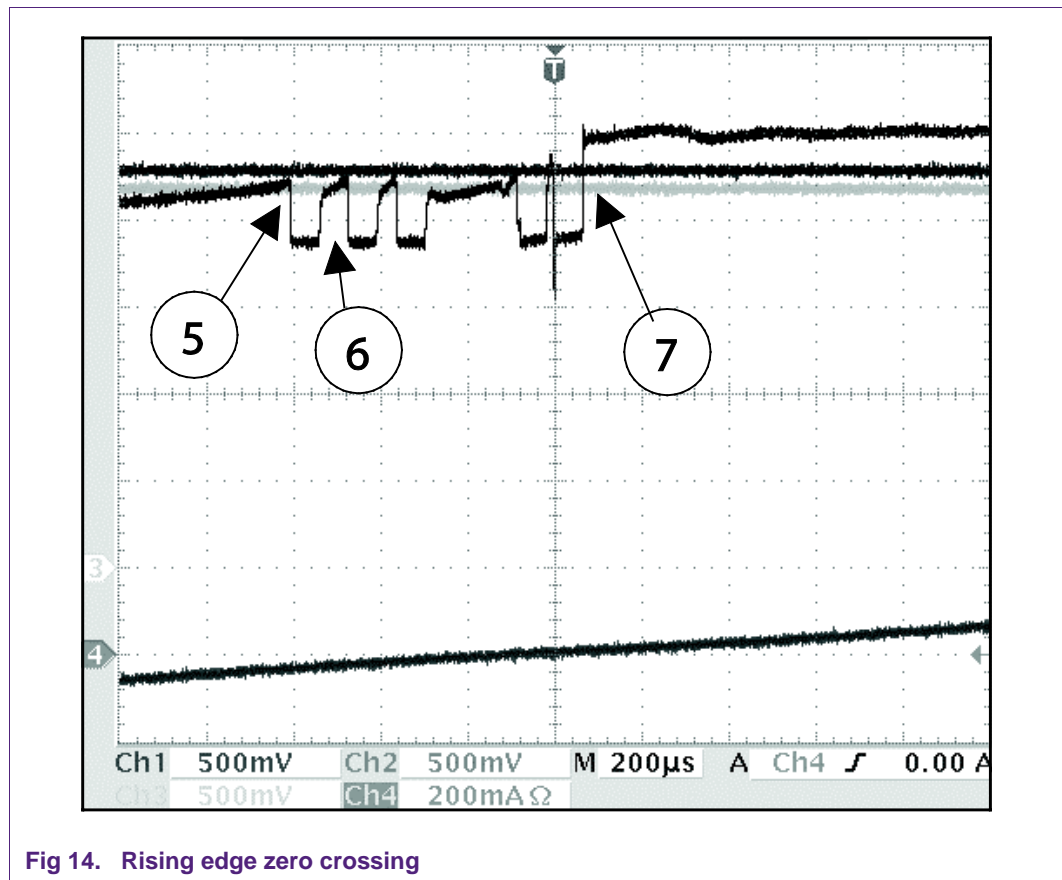

Fig 14. Rising edge zero crossing

Fig 14 is a zoom of the zero crossing event at the rising edge with the two voltage levels of the window comparator (channel 2 and 3), and the divided gate voltage at the comparator input (channel 1). Channel 4 shows the load current.

$V_{G-T1}$  enters the comparator window (5) and the LPC starts to trigger the triac for approximately  $70 \mu\text{s}$ . After that,  $V_{G-T1}$  re-enters the window (6) and the triac is triggered again until  $I_L$  is reached and the triac is latched ON (7).

Although not essential, the trigger pulse length can be adapted to the load if desired. Heavier loads are faster to reach the triac's latching current so the pulse duration can be minimized ( $10 \mu\text{s}$  minimum is recommended). For very small loads, e.g. small solenoids or synchronous motors, the pulse can be longer to reduce the retriggering events.

A program can poll the comparator registers or use the comparator interrupt or a combination of both.

This circuit can also be used to supervise the load current.

## 6. Triac supervision

The circuit for current zero crossing detection is well suited to supervising the latching status of the triac. If the triac commutates unexpectedly, the LPC will detect the gate voltage drop via the window comparator and can retrigger the triac, output an alarm warning and/or take countermeasures like turning the circuit off.

The LPC can also supervise the triac voltage between T1 and T2 with the circuit in [Fig 11](#) with R5 connected to main terminal 2 instead of neutral.

As another example, the LPC can provide protection against triac over-temperature and subsequent loss of control by monitoring triac temperature using the internal ADC. It can shut down the circuit in a safe and controlled manner before the triac becomes too hot and has lost the ability to turn off.

## 7. Synchronization to mains

The timing of a phase control circuit depends on the power requirement of the application and the characteristics (reactance) of the load. The half cycle time depends on the mains frequency (e.g. 50 Hz or 60 Hz). Different microcontroller clock frequencies will change the timing as well. The LPC has an internal 6 MHz oscillator with a tolerance of  $\pm 25\%$ . A universal application could calculate the mains frequency with a known oscillator frequency or vice versa.

With the example code below, an application can be independent of mains frequency and oscillator tolerance. The program measures the half cycle duration in relation to the oscillator frequency. The result is the number of timer increments per half cycle. The program stops and clears Timer 0 and waits for a zero crossing. After the zero crossing the timer is started. The program waits for four more zero crossings and stops Timer 0 again. The contents of Timer 0 are stored in the variable `halfwaveticks`. The variable is divided by four for the four half cycles. Now, `halfwaveticks` contains the number of Timer 0 increments per half cycle and a phase control application can calculate the phase delay from that variable.

For example, for a delay of 50 % of a half cycle, Timer 0 can be loaded with `halfwaveticks` divided by two. After that, the LPC waits for the expiration of the timer then triggers the triac. This can be done in a timer interrupt routine as shown in the example below. The routine is based on a mains frequency of 50/60 Hz and 6 MHz clock to prevent overruns.

```
void measurehalfwave(void)
{
    unsigned char i,time;
    TR0=0;
    TH0=0x00;
    TL0=0x00;
    i=0;
    CMP1=CMP1&0xfe; //Clear CMF1
    while(!(CMP1&0x01)){};
    TR0=1;
    CMP1=CMP1&0xfe; //Clear CMF1
    while(i<3)
    {
        if((CMP1&0x01))
        {
            for(time=0;time<250;time++){}
```

```

    CMP1=CMP1&0xfe; //Clear CMF1
    i++;
  }
}
while(!(CMP1&0x01)){};
CMP1=CMP1&0xfe; //Clear CMF1

TR0=0;
halfwave=TH0*256+TL0;
halfwave=halfwave>>2;
}

```

## 8. Emulation @ mains supply

In the development process it is often necessary to emulate the microcontroller. With the NXP PDS76x LPC emulator this is also easy at mains supply. The emulator's power supply and connection to the PC must be isolated, e.g. with an optical isolator for the RS232 connection and a potential-free DC supply. All precautions for safe working and operation to your local standards must be taken, like the use of isolation power transformers and earth leakage protection devices.

## 9. Power supply

The power supply in triac control applications is cost critical. An NXP LPC and triac control application has a very low power demand, so the power can be provided directly by the mains via a resistive and capacitive dropper network and a simple half wave rectifier. An expensive and space-consuming transformer is not necessary. An example circuit is shown in [Fig 15](#). For more details see NXP Fact Sheet 067 (order ref 9397 750 00759).

The positive supply (5 V) is connected directly to mains (line or neutral). The 5.6 V Zener diode, combined with the forward voltage drop of the rectifier diode, produce an IC voltage supply close to 5 V.

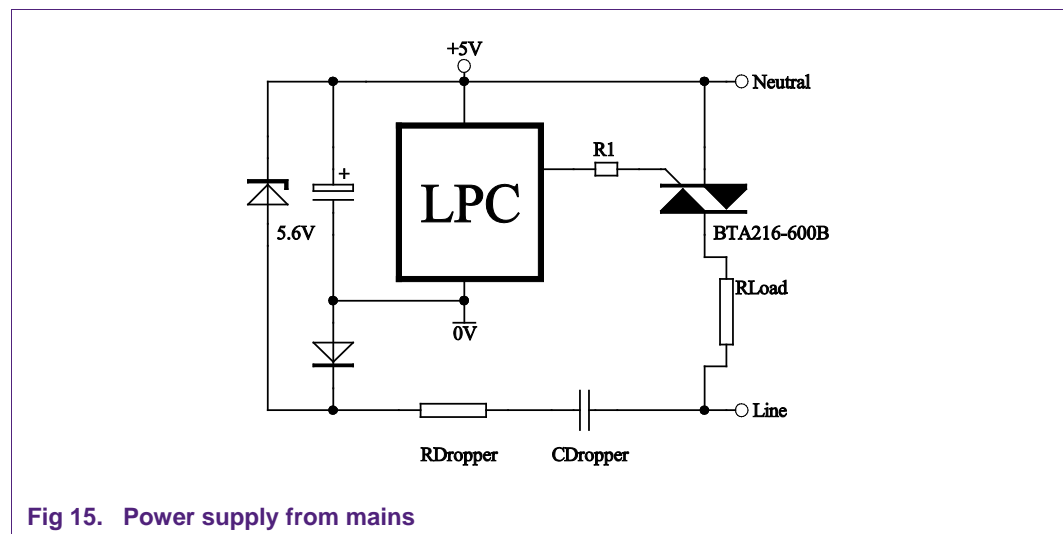

Fig 15. Power supply from mains

The storage capacitor is charged only in alternate half cycles of the mains supply, so its charging current must be more than twice the entire supply current I230V. The following



example calculation is based on the assumption of a total average current consumption at 5V of less than 5mA (trigger pulses and LPC supply current).

The current  $I_{230V}$  for  $U = 230\text{ V}$ ,  $f = 50\text{ Hz}$ ,  $C_{\text{Dropper}} = 220\text{ nF}$  and  $R_{\text{Dropper}} = 820\Omega$  is:

$$I_{230V} = \frac{230V}{\sqrt{R1^2 + \left(\frac{1}{2 \cdot \pi \cdot 50\text{Hz} \cdot C_{\text{Dropper}}}\right)^2}} \approx 15.8\text{mA}$$

The power dissipation of the dropper resistor R1 is:

$$P_{R_{\text{Dropper}}} = R_{\text{Dropper}} \cdot (15.8\text{mA})^2 \approx 0.2\text{W}$$

These calculation results can be applied to many different applications because of the very low LPC supply current, averaged over the mains cycle. The average current is so low because the gate trigger current is only applied for a very brief period in each half cycle, and the LPC can be often in the idle state with very low power consumption. In applications with very low supply current, and in many 110 V AC systems, the series capacitor can be removed to leave only a series dropper resistor of higher resistance (see Fig 16).

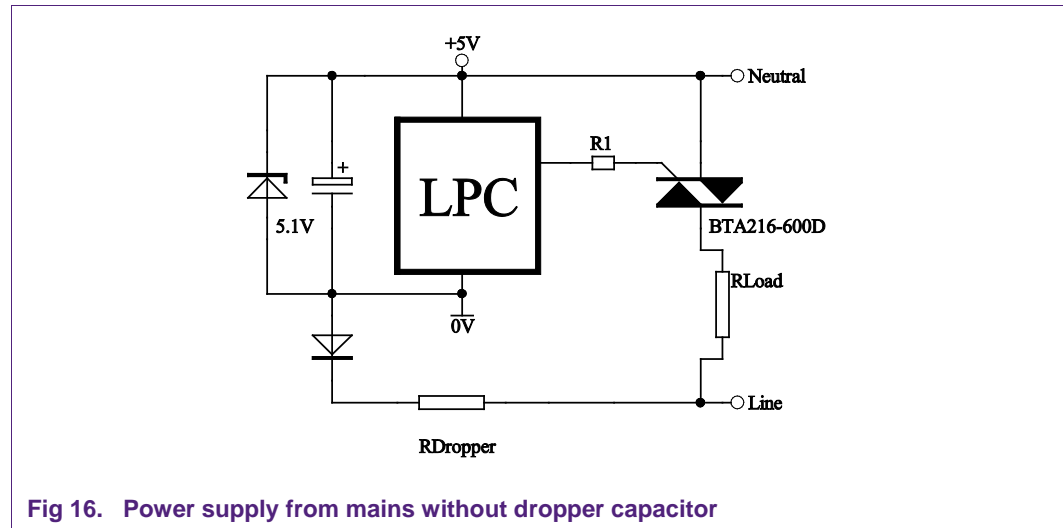

Fig 16. Power supply from mains without dropper capacitor

The following example calculation for 230 V mains is based on the assumption of a total current consumption at 5 V of less than 2 mA (trigger pulses and LPC supply current). As in the previous example, half wave rectification is used, so the charging current of the storage capacitor must be more than twice the 5 V-supply current.

$$R_{\text{Dropper}} = \frac{230V}{4\text{mA}} \approx 56\text{k}\Omega$$

A resistor of 56kΩ can source such a circuit. The power dissipation of  $R_{\text{Dropper}}$  is:

$$P_{R_{\text{Dropper}}} = R_{\text{Dropper}} \cdot (2\text{mA})^2 \approx 0.25\text{W} .$$

## 10. Phase control example

### 10.1 Description

The first example is a circuit to phase control resistive loads by ramping power up and down periodically. The LPC software initializes the LPC peripheral, measures four half cycles and calculates the duration of an average half cycle. The main program calculates the Timer 0 reload values from the phase value *phase*, and the half cycle duration. The phase control is done with the comparator and the timer interrupt. The comparator interrupt happens every voltage zero crossing, reloads Timer 0, starts the timer and increments or decrements *phase* depending on the direction. The timer interrupt triggers the triac gate with a variable pulse train; therefore the timer delay and the timer reload values define the phase angle. This example ramps power up and down and can be easily modified to allow phase angle to be controlled via remote control (UART), ADC or push buttons.

### 10.2 Schematic

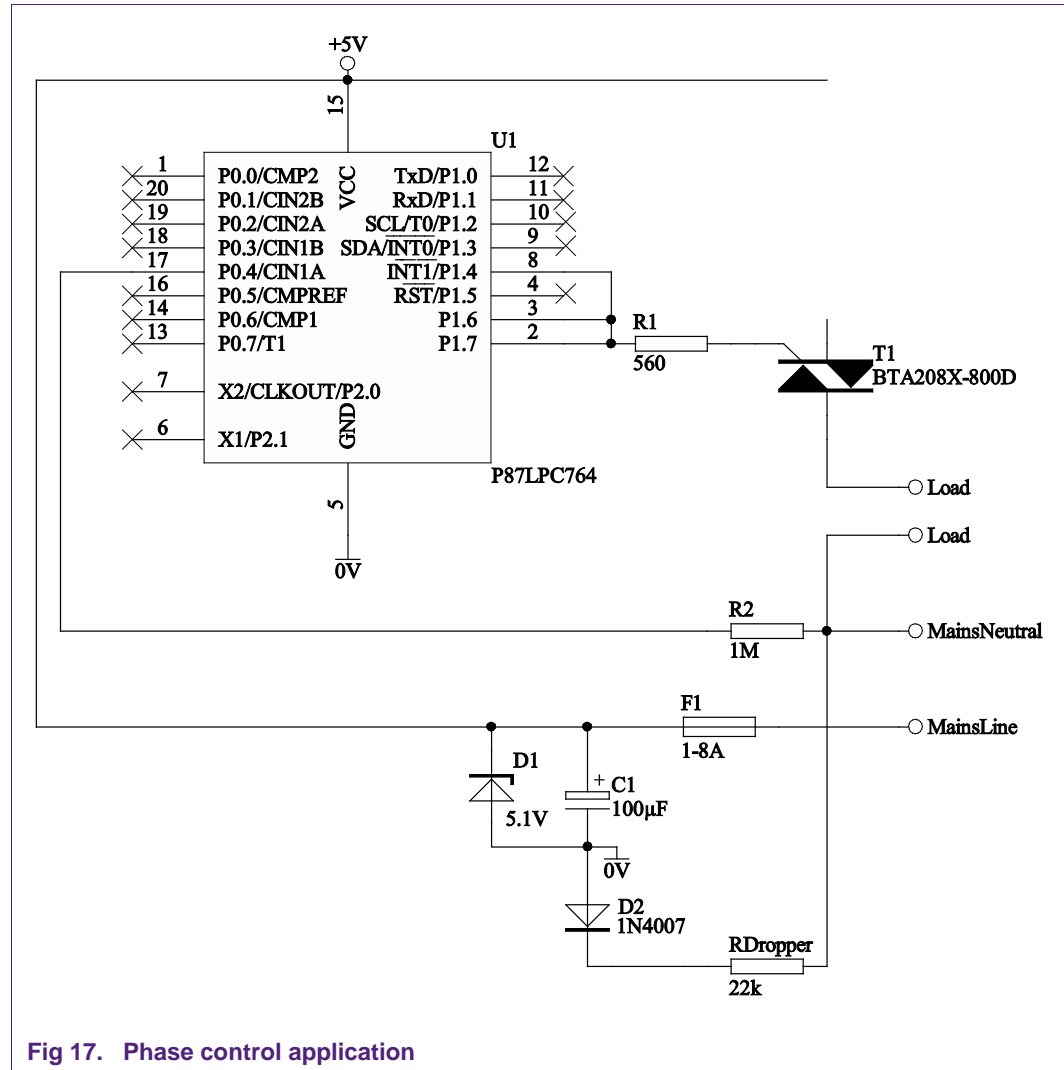

Fig 17. Phase control application

## 10.3 Software

The software is tested with the Resonance RKIT Version 6.1.1 and not tested with other compilers. For other compilers the software must be adapted.

```

/*=====*/
/*
; SOURCE_FILE: main.c
; APPLICATION: 80LPC764 phase control
; PS MCO-Hamburg
; VERSION: 1.0
; DATE: 2000/11/01
;;
(C) 2000: Philips
/*=====*/

#include <relpc768.h>

at 0xfd00 char code UCFG1=0x7B; //RC oscillator

unsigned char    phase,TH0reload,TL0reload;
unsigned int     halfwave,t0delay;
bit             up;

void comparatorl1sr(void) interrupt 12
{
    EC1=0;
    TR0=0;                //Timer 0 off
    TH0=TH0reload;       //Reload Timer 0
    TL0=TL0reload;
    TF0=0;
    ET0=1;                //Enable Timer 0 Int
    TR0=1;                //Timer 0 on
    CMP1=CMP1&0xFE;      //Clear CMF1
    EC1=1;                //Enable compl
}

interrupt

    if(up)                //dim up or down
    {phase++;}
    else
    {phase--;}

    if(phase<=0x10||phase>=0xF0)
    {up=!up;}            //toggle direction
}

void timer0Isr(void) interrupt 1
{
    unsigned char pulsecount,pulseduration;

    ET0=0;                //Disable T0 Interrupt
    pulsecount=3;         //set pulse number
    pulseduration=50;     //set pulse duration

    while(pulsecount)    //pulsetrain
    {
        P1=P1&0x23;      //Pulse low P1 (on)
        while(pulseduration)
        {pulseduration--;}
        P1=P1|0xDC;      //Pulse high P1 (off)
        pulsecount--;
    }
}

void InitComparator(void)
{
    PT0AD=0x50;          //Disable digital i/o
    P0=0x0FF;
    POM2=0xEF;           //Set P0
    POM1=0x10;
}

```

```

P1=0xFF;
P1M2=0xDD;           //Set P1
P1M1=0x22;

CMP1=0x2C;           //Cin1A+COMPREF int,OE
CMP2=0x0;            //off
}

void InitInterrupts(void)
{
  IP0=0x02;           //Interrupt priorities
  IP0H=0x00;          //Comp1 : 3, Comp2: 3

  IP1=0x24;           //Timer0: 1, Ser : 0
  IP1H=0x24;

  EC1=1;              //Enable compl
interrupt
  ET0=1;              //Enable T0 interrupt
}

void measurehalfwave(void)
{
  unsigned char i,time;
  TR0=0;              //stop timer
  TH0=0x00;           //init timer
  TL0=0x00;
  I=0;
  CMP1=CMP1&0xfe;     //Clear CMF1
  while(!(CMP1&0x01)){//wait for zerocross
  TR0=1;              //start timer
  CMP1=CMP1&0xfe;     //Clear CMF1
  while(i<3)          //wait 3 zerocrossings
  {
    if((CMP1&0x01))  //wait for
zerocrossing
    {
      for(time=0;time<250;time++)
    {
      //no doubletrigger
delay
      CMP1=CMP1&0xfe; //Clear CMF1
      i++;             //count zerocrossing
    }
  }
  while(!(CMP1&0x01)){//wait for last zc
  TR0=0;              //stop timer
  CMP1=CMP1&0xfe;     //Clear CMF1
  halfwave=(unsigned int)((TH0<<8)|TL0);
  //store timer
  halfwave=halfwave>>2; //interval 1 halfwave
}

void main(void)
{
  InitComparator();
  TMOD=0x21;
  phase=50;
  TH0reload=0xF8;
  TL0reload=0x80;
  InitInterrupts();
  TCON=0x050;         // Timer 0 + 1 on
  CMP1=CMP1&0xfe;     //Clear CMF1
  measurehalfwave();
  up=0;

  EA=1;               //Enable interrupts
  while(1)
  {
    //calculate timer delay/reload from phase

```

```
t0delay=(unsigned int)((halfwave>>8)*phase);
t0delay=(unsigned int)(0xFFFF-t0delay);

TH0reload=((char*) (&t0delay))[0];
TL0reload=((char*) (&t0delay))[1];

// PCON=PCON|0x01; //idle mode
}
}
```

## 11. Continuous conduction example

### 11.1 Description

The second example is a universal circuit to switch any inductive or resistive load on and off, with continuous conduction in the ON state, as described in section 5.4. The zero load current detection is done in a simple software loop that polls the LPC comparators. In more sophisticated applications this can also be interrupt driven. The initial triac gate pulse is timed by voltage zero crossing to minimize EMI and to allow controlled, predefined start-up of the load from the beginning of a mains cycle. The software waits a couple of half cycles before switching on. This example switches the load on after reset, but it can be easily modified so that the load is controlled via UART, ADC or push buttons.

11.1.1 Schematic

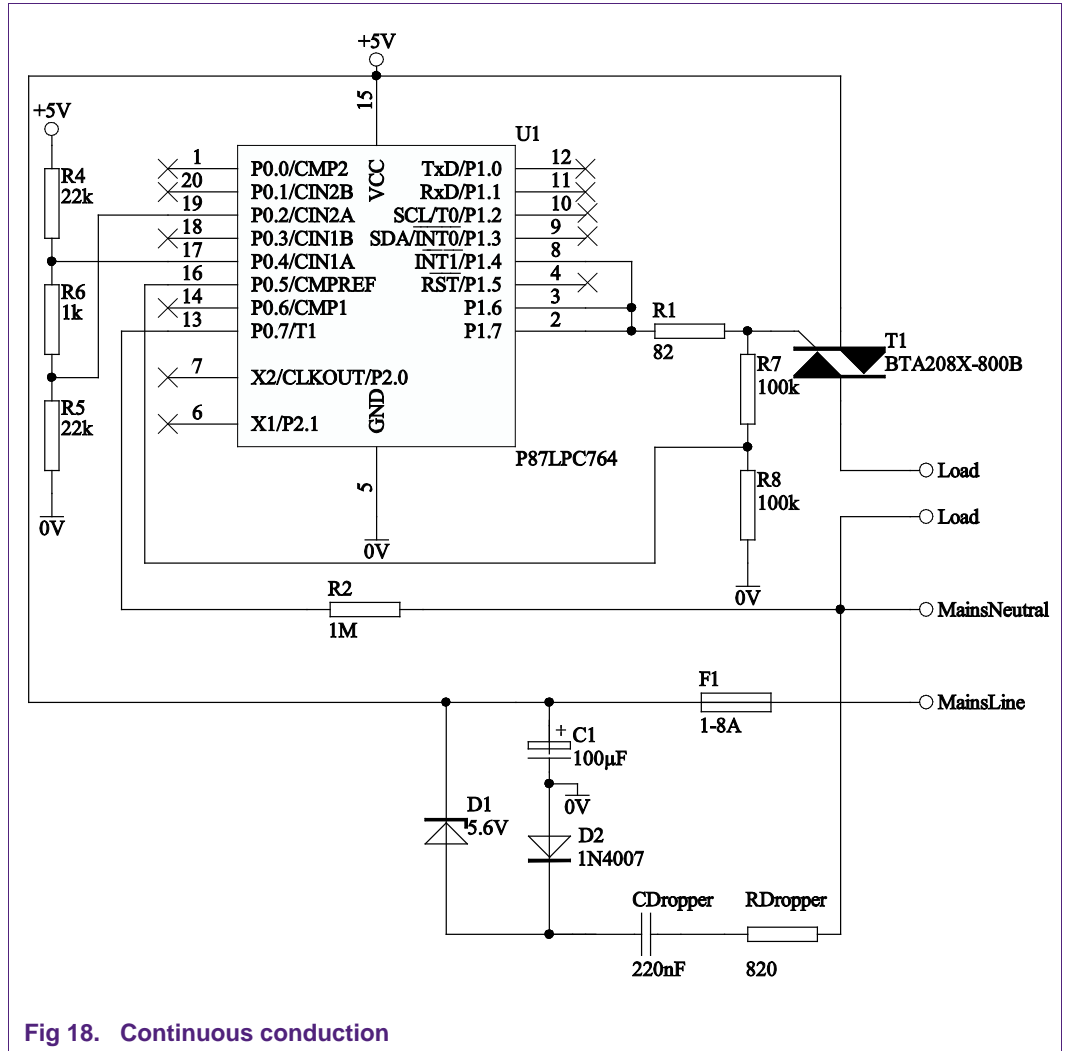

Fig 18. Continuous conduction

### 11.1.2 Software

The software is tested with the Resonance RKIT Version 6.1.1 and not tested with other compilers. For other compilers the software must be adapted.

```

/*=====*/
/*
; SOURCE_FILE:      main.c
; APPLICATION:      80LPC764 continuous conduction
; PS MCO-Hamburg
; VERSION:         1.0
; DATE:            2000/11/01
;
; (C) 2000: Philips
/*=====*/

#include <relpc768.h>

at 0xfd00 char code UCFG1=0x7B; //RC oscillator

void InitComparator(void)
{
PT0AD=0x75;          // Disable digital i/o
P0=0x0FF;
POM2=0x4B;          // Set P0
POM1=0xB4;

P1=0xFF;
P1M2=0xC7;          // Set P1
P1M1=0x38;

CMP1=0x24;          // Cin1A + CMPREF
int,OE
CMP2=0x24;          // dito
}
void main(void)
{
unsigned char pulsecount,pulseduration;

InitComparator();

while(P0&0x80){}; //wait for voltage
while(!(P0&0x80)){}; //zero crossings 5
while(P0&0x80){}; //times at P0.7
while(!(P0&0x80)){};
while(P0&0x80){};
while(1) //do forever
{
if(((CMP1&0x2)) && !(CMP2&0x2))
//gatevoltage in window?
{
pulsecount=1;
while(pulsecount) //pulsetrain
{
P1=P1&0x23; //Pulse low P1 (on)
pulseduration=10;
while(pulseduration)
{pulseduration--;}
P1=P1|0xDC; //Pulse high P1 (off)
pulsecount--;
}
}
}
}
}

```

## 12. Conclusion

---

This application note has shown some examples and solutions for controlling resistive and inductive loads with NXP's LPC and Triacs. The range is from low power highly inductive loads like solenoids, valves and synchronous motors, to high power loads like motors and heaters at mains supply. This can be achieved with a very low part count in a very space-efficient manner using small outline packages, e.g. TSSOP for the LPC and SOT223 for the triac. The described functions are basic and can be extended easily with the embedded features of the LPC to improve, for example, the human-machine interface or implement regulation algorithms with feedback from the environment.



## 13. References

---

For further details please refer to the following publications:

- [1] Datasheets: [www.nxp.com](http://www.nxp.com)
- [2] Fact Sheet 013/014 “‘Hi-Com’ – a three-quadrant triac” (order ref 9397 750 06504)  
[http://www.nxp.com/documents/application\\_note/FS013-014.pdf](http://www.nxp.com/documents/application_note/FS013-014.pdf)
- [3] Fact Sheet 067 “Logic level and sensitive gate triacs”(order ref 9397 750 00759)  
[http://www.nxp.com/documents/application\\_note/FS067.pdf](http://www.nxp.com/documents/application_note/FS067.pdf)
- [4] Application Note “Thyristors & Triacs – Ten Golden Rules for Success In Your Application” (order ref 9397 750 00812)  
[http://www.nxp.com/documents/application\\_note/AN\\_GOLDEN\\_RULES.pdf](http://www.nxp.com/documents/application_note/AN_GOLDEN_RULES.pdf)
- [5] Application Note “Three-quadrant triacs bring major benefits to OEMs” (order ref 9397 750 06518)  
[http://www.nxp.com/documents/application\\_note/AN\\_3Q\\_TRIACS.pdf](http://www.nxp.com/documents/application_note/AN_3Q_TRIACS.pdf)
- [6] Leaflet “Three-quadrant triacs. Simplifying the design of power-control circuitry for nonresistive loads” (order ref 9397 750 06551)  
[http://www.nxp.com/documents/application\\_note/MCU\\_51LPC\\_3QUADRANTTRIA\\_CS.pdf](http://www.nxp.com/documents/application_note/MCU_51LPC_3QUADRANTTRIA_CS.pdf)
- [7] AN466: In-system programming of the P87LPC76x family of microcontrollers  
[http://www.nxp.com/documents/application\\_note/AN466.pdf](http://www.nxp.com/documents/application_note/AN466.pdf)
- [8] U.S. Patent: 5,734,289
- [9] International Patent: WO96/31003

## 14. Legal information

### 14.1 Definitions

**Draft** — The document is a draft version only. The content is still under internal review and subject to formal approval, which may result in modifications or additions. NXP Semiconductors does not give any representations or warranties as to the accuracy or completeness of information included herein and shall have no liability for the consequences of use of such information.

### 14.2 Disclaimers

**Limited warranty and liability** — Information in this document is believed to be accurate and reliable. However, NXP Semiconductors does not give any representations or warranties, expressed or implied, as to the accuracy or completeness of such information and shall have no liability for the consequences of use of such information. NXP Semiconductors takes no responsibility for the content in this document if provided by an information source outside of NXP Semiconductors.

In no event shall NXP Semiconductors be liable for any indirect, incidental, punitive, special or consequential damages (including - without limitation - lost profits, lost savings, business interruption, costs related to the removal or replacement of any products or rework charges) whether or not such damages are based on tort (including negligence), warranty, breach of contract or any other legal theory.

Notwithstanding any damages that customer might incur for any reason whatsoever, NXP Semiconductors' aggregate and cumulative liability towards customer for the products described herein shall be limited in accordance with the Terms and conditions of commercial sale of NXP Semiconductors.

**Right to make changes** — NXP Semiconductors reserves the right to make changes to information published in this document, including without limitation specifications and product descriptions, at any time and without notice. This document supersedes and replaces all information supplied prior to the publication hereof.

**Suitability for use** — NXP Semiconductors products are not designed, authorized or warranted to be suitable for use in life support, life-critical or safety-critical systems or equipment, nor in applications where failure or malfunction of an NXP Semiconductors product can reasonably be expected to result in personal injury, death or severe property or environmental damage. NXP Semiconductors and its suppliers accept no liability for inclusion and/or use of NXP Semiconductors products in such equipment or applications and therefore such inclusion and/or use is at the customer's own risk.

**Applications** — Applications that are described herein for any of these products are for illustrative purposes only. NXP Semiconductors makes no representation or warranty that such applications will be suitable for the specified use without further testing or modification.

Customers are responsible for the design and operation of their applications and products using NXP Semiconductors products, and NXP Semiconductors accepts no liability for any assistance with applications or customer product design. It is customer's sole responsibility to determine whether the NXP Semiconductors product is suitable and fit for the customer's applications and products planned, as well as for the planned application and use of customer's third party customer(s). Customers should provide appropriate design and operating safeguards to minimize the risks associated with their applications and products.

NXP Semiconductors does not accept any liability related to any default, damage, costs or problem which is based on any weakness or default in the customer's applications or products, or the application or use by customer's third party customer(s). Customer is responsible for doing all necessary testing for the customer's applications and products using NXP Semiconductors products in order to avoid a default of the applications and the products or of the application or use by customer's third party customer(s). NXP does not accept any liability in this respect.

**Export control** — This document as well as the item(s) described herein may be subject to export control regulations. Export might require a prior authorization from competent authorities.

**Evaluation products** — This product is provided on an "as is" and "with all faults" basis for evaluation purposes only. NXP Semiconductors, its affiliates and their suppliers expressly disclaim all warranties, whether express, implied or statutory, including but not limited to the implied warranties of non-infringement, merchantability and fitness for a particular purpose. The entire risk as to the quality, or arising out of the use or performance, of this product remains with customer.

In no event shall NXP Semiconductors, its affiliates or their suppliers be liable to customer for any special, indirect, consequential, punitive or incidental damages (including without limitation damages for loss of business, business interruption, loss of use, loss of data or information, and the like) arising out of the use of or inability to use the product, whether or not based on tort (including negligence), strict liability, breach of contract, breach of warranty or any other theory, even if advised of the possibility of such damages.

Notwithstanding any damages that customer might incur for any reason whatsoever (including without limitation, all damages referenced above and all direct or general damages), the entire liability of NXP Semiconductors, its affiliates and their suppliers and customer's exclusive remedy for all of the foregoing shall be limited to actual damages incurred by customer based on reasonable reliance up to the greater of the amount actually paid by customer for the product or five dollars (US\$5.00). The foregoing limitations, exclusions and disclaimers shall apply to the maximum extent permitted by applicable law, even if any remedy fails of its essential purpose.

### 14.3 Trademarks

Notice: All referenced brands, product names, service names and trademarks are property of their respective owners.

## 15. List of figures

---

Fig 1.	Block diagram of phase control with voltage zero-crossing detection .....	4
Fig 2.	Block diagram of phase control with current zero-crossing detection .....	4
Fig 3.	Phase control .....	5
Fig 4.	Continuous conduction .....	6
Fig 5.	Triac triggering quadrants .....	7
Fig 6.	High drive capability with combined pins .....	8
Fig 7.	Triac drive with external transistor .....	8
Fig 8.	Internal clamping diodes .....	9
Fig 9.	Zero crossing detection with single comparator .....	10
Fig 10.	High precision zero crossing detection with single comparator .....	10
Fig 11.	Window comparator used as line voltage detector .....	11
Fig 12.	Window comparator used as gate voltage and current zero crossing detector .....	12
Fig 13.	Oscillogram of current zero crossing detection circuit .....	13
Fig 14.	Rising edge zero crossing .....	14
Fig 15.	Power supply from mains .....	16
Fig 16.	Power supply from mains without dropper capacitor .....	17
Fig 17.	Phase control application .....	18
Fig 18.	Continuous conduction .....	22

## 16. Contents

---

<b>1.</b>	<b>Introduction .....</b>	<b>3</b>
<b>2.</b>	<b>Phase control and switching.....</b>	<b>5</b>
2.1	Phase control .....	5
2.2	Switching.....	6
<b>3.</b>	<b>Triac choice .....</b>	<b>6</b>
<b>4.</b>	<b>Triac driving.....</b>	<b>7</b>
<b>5.</b>	<b>Zero-crossing detection.....</b>	<b>9</b>
5.1	Voltage zero crossing - simple input .....	9
5.2	Voltage zero crossing - comparator .....	10
5.3	Voltage zero crossing – window comparator ....	11
5.4	Current zero crossing – window comparator ....	11
<b>6.</b>	<b>Triac supervision.....</b>	<b>15</b>
<b>7.</b>	<b>Synchronization to mains.....</b>	<b>15</b>
<b>8.</b>	<b>Emulation @ mains supply.....</b>	<b>16</b>
<b>9.</b>	<b>Power supply .....</b>	<b>16</b>
<b>10.</b>	<b>Phase control example .....</b>	<b>18</b>
10.1	Description .....	18
10.2	Schematic .....	18
10.3	Software .....	19
<b>11.</b>	<b>Continuous conduction example.....</b>	<b>21</b>
11.1	Description .....	21
11.1.1	Schematic .....	22
11.1.2	Software .....	23
<b>12.</b>	<b>Conclusion.....</b>	<b>24</b>
<b>13.</b>	<b>References .....</b>	<b>25</b>
<b>14.</b>	<b>Legal information .....</b>	<b>26</b>
14.1	Definitions .....	26
14.2	Disclaimers.....	26
14.3	Trademarks .....	26
<b>15.</b>	<b>List of figures.....</b>	<b>27</b>
<b>16.</b>	<b>Contents.....</b>	<b>28</b>

---

Please be aware that important notices concerning this document and the product(s) described herein, have been included in the section 'Legal information'.

---