

COMMITTEE BD-006

DR AS/NZS 1170.2

(Project ID: 7506)

Draft for Public Comment Australian/New Zealand Standard

LIABLE TO ALTERATION—DO NOT USE AS A STANDARD

**BEGINNING DATE
FOR COMMENT:** 20 October 2009

**CLOSING DATE
FOR COMMENT:** 21 December 2009

Important: The procedure for public comment has changed - please read the instructions on the inside cover of this document.

**Structural design actions
Part 2: Wind actions
(Revision of AS 1170.2—2002)**

STANDARDS
Australia

STANDARDS
NEW ZEALAND
PAEREWĀ AOTEAROA

COPYRIGHT

Draft for Public Comment Australian/New Zealand Standard

The committee responsible for the issue of this draft comprised representatives of organizations interested in the subject matter of the proposed Standard. These organizations are listed on the inside back cover.

Comments are invited on the technical content, wording and general arrangement of the draft.

The method for submission of comment on this document is to register and fill in an online form via Standards Hub Website. Instructions and examples of comment submission are available on the website. . Please use the following link—

<https://www.hubstandards.org.au/hub/public/listOpenCommentingPublication.action>

Comment must be via Hub, any emails or forms sent to us by fax or mail will not be considered by the Committee when it reviews the Public Comment received.

Please place relevant clause numbers beside each comment.

Editorial matters (i.e. spelling, punctuation, grammar etc.) will be corrected before final publication.

The coordination of the requirements of this draft with those of any related Standards is of particular importance and you are invited to point out any areas where this may be necessary.

Please provide supporting reasons and suggested wording for each comment. Where you consider that specific content is too simplistic, too complex or too detailed please provide an alternative.

If the draft is acceptable without change, an acknowledgment to this effect would be appreciated.

Once you have registered and submitted your comments via the online form, your comments are automatically submitted to the committee for review.

Normally no acknowledgment of comment is sent. All comments received via the Standards Hub Website by the due date will be reviewed and considered by the relevant drafting committee. We cannot guarantee that comments submitted in other forms will be considered along with those submitted via the Standards Hub online form. Where appropriate, changes will be incorporated before the Standard is formally approved.

If you know of other persons or organizations that may wish to comment on this draft Standard, could you please advise them of its availability. Further copies of the draft are available from the Publisher SAI Global at <http://www.saiglobal.com/>

SAI GLOBAL Customer Service Centre

Telephone: 13 12 42

Facsimile: 1300 65 49 49

e-mail: <mailto:sales@saiglobal.com>

Internet: <http://www.saiglobal.com/shop>

Draft for Public Comment

STANDARDS AUSTRALIA/STANDARDS NEW ZEALAND

Committee BD-006—General Design Requirements and Loading on Structures

Subcommittee BD-006-02—Wind Loads

DRAFT

Australian/New Zealand Standard

Structural design actions

Part 2: Wind actions

(Revision of AS 1170.2—2002)

(To be AS/NZS 1170.2:200X)

Comment on the draft is invited from people and organizations concerned with this subject. It would be appreciated if those submitting comment would follow the guidelines given on the inside front cover.

Important: The procedure for public comment has changed – please read the instructions on the inside cover of this document

This document is a draft Australian/New Zealand Standard only and is liable to alteration in the light of comment received. It is not to be regarded as an Australian/New Zealand Standard until finally issued as such by Standards Australia/Standards New Zealand.

PREFACE

This Standard was prepared by the Joint Standards Australia/Standards New Zealand Committee, BD-006, General Design Requirements and Loading on Structures, to supersede AS/NZS 1170.2:2002.

The objective of this Standard is to provide designers of structures with wind actions for use in the design of structures subject to wind action. It provides a detailed procedure for the determination of wind actions on structures, varying from those less sensitive to wind action to those for which dynamic response must be taken into consideration.

The objectives of this revision are to remove ambiguities, to incorporate recent research and experiences from recent severe wind events in Australia and New Zealand.

This Standard is Part 2 of the AS/NZS 1170 series *Structural design actions*, which comprises the following parts:

- AS/NZS 1170, Structural design actions
- Part 0: General principles
- Part 1: Permanent, imposed and other actions
- Part 2: Wind actions
- Part 3: Snow and ice actions
- Part 4: Earthquake actions in Australia
- Part 5: Earthquake actions – New Zealand

The Commentary to this Standard is AS/NZS 1170.2 Supp 1, *Structural design actions—Wind actions—Commentary* (Supplement to AS/NZS 1170.2:2010).

The wind speeds provided are based on existing data. No account has been taken of any trend in wind speeds due to climatic change.

This Standard is based on ISO 4354:1997, *Wind actions on structures*. ISO 4354:1997 gives general format and guidance on detail for the drafting of national Standards on wind actions.

This edition differs from the previous editions as follows:

- (a) A torsional loading requirement in the form of an eccentricity of loading is prescribed for tall buildings (greater than 50 m in height). (Clause 2.5.4).
- (b) Addition of windborne debris impact loading criteria (Clause 2.5.7).
- (c) Regional wind speeds V_1 , V_{250} , V_{2500} , V_{5000} and V_{10000} have been added for serviceability design requirements, for design of public storm shelters and for compatibility with AS/NZS 1170.0. (Clause 3.2).
- (d) Nominally closed doors, such as roller doors, to be treated as potential dominant openings unless it is shown that the doors and their supports and fixings are capable of resisting the applied wind loads and the impact of debris. (Clause 5.3.2).
- (e) Addition of a new clause requiring consideration of wind loads on internal walls and partitions. (Clause 5.3.4).
- (f) Adjustment of internal pressure coefficients for dominant openings on leeward walls, side walls and roof, to more correctly reflect the relationship between internal and external pressures when multiple opening occur (Table 5.1(B)).
- (g) Clause 5.4.3 on the combination factor (K_c) has been changed to remove some ambiguities and confusion in the previous version. An expanded Table 5.5 gives more examples of the use of this factor.

- (h) Several changes to Table 5.6 on local pressure factors have been made, including the following:
- (i) A factor of 1.5 for small areas on windward walls.
 - (ii) A factor of 3.0 for small areas near the corners of roofs.
 - (iii) Case SA5 ($K_e = 3.0$) will, in future, not be required to be applied to those buildings greater than 25 m in height with low aspect ratios.
- (i) Values for structural damping ratios for structures with dynamic response to wind have been removed,
NOTE: Users should seek other sources including the AS/NZS 1170.2 Supp 1, for advice on possible values of damping as a function of height of building and amplitude of vibration.
- (j) A note to Table C3, Appendix C, for shape factors for curved roofs has been added to cover the case of building height to rise greater than 2.
- (k) The load distribution specified in Paragraph D5, Appendix D, for Cantilevered roofs has been revised to reflect recent research.
- (l) Drag coefficients for pentagonal sections have been added to Table E4, Appendix E.
- (m) Drag coefficients for sections of UHF television antennas Types 1 and 3 in Table E7, Appendix E, have been revised. The value of drag force coefficients for the Type 2 antenna have been removed from the Standard, since this type has not been used in Australia or New Zealand for many years.

The Joint Committee has considered exhaustive research and testing information from Australian, New Zealand and overseas sources in the preparation of this Standard. The design wind actions prescribed in this Standard are the minimum for the general cases described.

The terms 'normative' and 'informative' have been used in this Standard to define the application of the appendix to which they apply. A 'normative' appendix is an integral part of a Standard, whereas an 'informative' appendix is only for information and guidance.

Statements expressed in mandatory terms in notes to tables and figures are deemed to be an integral part of this Standard.

Notes to the text contain information and guidance and are not considered to be an integral part of the Standard.

CONTENTS

	<i>Page</i>
SECTION 1 GENERAL	
1.1 SCOPE	5
1.2 APPLICATION	5
1.3 NORMATIVE REFERENCES	5
1.4 DETERMINATION OF WIND ACTIONS	6
1.5 UNITS	6
1.6 DEFINITIONS	6
1.7 NOTATION	6
SECTION 2 CALCULATION OF WIND ACTIONS	
2.1 GENERAL	7
2.2 SITE WIND SPEED	7
2.3 DESIGN WIND SPEED	7
2.4 DESIGN WIND PRESSURE AND DISTRIBUTED FORCES	10
2.5 WIND ACTIONS	10
SECTION 3 REGIONAL WIND SPEEDS	
3.1 GENERAL	13
3.2 REGIONAL WIND SPEEDS (V_R)	13
3.3 WIND DIRECTION MULTIPLIER (M_d)	13
3.4 FACTORS FOR REGIONS C AND D (F_C, F_D)	14
SECTION 4 SITE EXPOSURE MULTIPLIERS	
4.1 GENERAL	17
4.2 TERRAIN/HEIGHT MULTIPLIER ($M_{z,cat}$)	17
4.3 SHIELDING MULTIPLIER (M_s)	20
4.4 TOPOGRAPHIC MULTIPLIER (M_t)	21
SECTION 5 AERODYNAMIC SHAPE FACTOR	
5.1 GENERAL	25
5.2 EVALUATION OF AERODYNAMIC SHAPE FACTOR	28
5.3 INTERNAL PRESSURE FOR ENCLOSED RECTANGULAR BUILDINGS	28
5.4 EXTERNAL PRESSURES FOR ENCLOSED RECTANGULAR BUILDINGS	31
5.5 FRICTIONAL DRAG FORCES FOR ENCLOSED BUILDINGS	39
SECTION 6 DYNAMIC RESPONSE FACTOR	
6.1 EVALUATION OF DYNAMIC RESPONSE FACTOR	41
6.2 ALONG-WIND RESPONSE OF TALL BUILDINGS AND TOWERS	41
6.3 CROSSWIND RESPONSE	44
6.4 COMBINATION OF ALONG-WIND AND CROSSWIND RESPONSE	48

STANDARDS AUSTRALIA/STANDARDS NEW ZEALAND

Australian/New Zealand Standard
Structural design actions

Part 2: Wind actions

SECTION 1 GENERAL

1.1 SCOPE

This Standard sets out procedures for determining wind speeds and resulting wind actions to be used in the structural design of structures subjected to wind actions other than those caused by tornadoes.

The Standard covers structures within the following criteria:

- (a) Buildings less than or equal to 200 m high.
- (b) Structures with roof spans less than 100 m.
- (c) Structures other than offshore structures, bridges and transmission towers.

NOTES:

- 1 This Standard is a stand-alone document for structures within the above criteria. It may be used, in general, for all structures but other information may be necessary. Guidance on wind tunnel testing, reliable references and alternative data is given in AS/NZS 1170.2 Supp 1.
- 2 Where structures have natural frequencies less than 1 Hz, Section 6 requires dynamic analysis to be carried out (see Section 6).
- 3 In this document, the words 'this Standard' indicate AS/NZS 1170.2, which is regarded as Part 2 of the AS/NZS 1170 series of Standards (see Preface).
- 4 Further advice should be sought for geometries not described in this Standard such as the roofs of podiums below tall buildings.

1.2 APPLICATION

This Standard shall be read in conjunction with AS/NZS 1170.0.

This Standard may be used as a means for demonstrating compliance with the Requirements of Part B1 of the Building Code of Australia.

NOTE: Use of methods or information not given in this Standard should be justified by a special study (see AS/NZS 1170.0).

1.3 NORMATIVE REFERENCES

The following documents are referred to in this Standard:

AS

- 4040 Methods of testing sheet roof and wall cladding
- 4040.3 Part 3: Resistance to wind pressures for cyclone regions

AS/NZS

- 1170 Structural design actions
- 1170.0 Part 0: General principles

AS/NZS
4505 Domestic garage doors
Building Code of Australia

1.4 DETERMINATION OF WIND ACTIONS

Values of wind actions (W) for use in design shall be established. The values shall be appropriate for the type of structure or structural element, its intended use, design working life and exposure to wind action.

The following wind actions, determined in accordance with this Standard (using the procedures detailed in Section 2 and the values given in the remaining Sections), shall be deemed to comply with the requirements of this Clause:

- (a) W_u determined using a regional wind speed appropriate to the annual probability of exceedence (P) specified for ultimate limit states as given in AS/NZS 1170.0, or the Building Code of Australia.
- (b) W_s determined using a regional wind speed appropriate to the annual probability of exceedence for the serviceability limit states (see Note 3).

NOTES:

- 1 Information on serviceability conditions and criteria can be found in AS/NZS 1170.0 (see Preface).
- 2 Some design processes require the determination of wind pressure (ultimate or serviceability wind pressure). Such pressures should be calculated for the wind speed associated with the annual probability of exceedence (P) appropriate to the limit state being considered.
- 3 For guidance on Item (b), see AS/NZS 1170.0.

1.5 UNITS

Except where specifically noted, this Standard uses the SI units of kilograms, metres, seconds, pascals, newtons, degrees and hertz (kg, m, s, Pa, N, Hz).

1.6 DEFINITIONS

Definitions of the terms used in this Standard are given in Appendix A.

1.7 NOTATION

The notation used in this Standard is given in Appendix B.

SECTION 2 CALCULATION OF WIND ACTIONS

2.1 GENERAL

The procedure for determining wind actions (W) on structures and elements of structures or buildings shall be as follows:

- (a) Determine site wind speeds (see Clause 2.2).
- (b) Determine design wind speed from the site wind speeds (see Clause 2.3).
- (c) Determine design wind pressures and distributed forces (see Clause 2.4).
- (d) Calculate wind actions (see Clause 2.5).

2.2 SITE WIND SPEED

The site wind speeds ($V_{\text{sit},\beta}$) defined for the 8 cardinal directions (β) at the reference height (z) above ground (see Figure 2.1) shall be as follows:

$$V_{\text{sit},\beta} = V_R M_d (M_{z,\text{cat}} M_s M_t) \quad \dots 2.2$$

where

V_R = regional 3 s gust wind speed, in metres per second, for annual probability of exceedence of $1/R$, as given in Section 3

M_d = wind directional multipliers for the 8 cardinal directions (β) as given in Section 3

$M_{z,\text{cat}}$ = terrain/height multiplier, as given in Section 4

M_s = shielding multiplier, as given in Section 4

M_t = topographic multiplier, as given in Section 4

Generally, the wind speed is determined at the average roof height (h). In some cases this varies, as given in the appropriate sections, according to the structure.

2.3 DESIGN WIND SPEED

The building orthogonal design wind speeds ($V_{\text{des},\theta}$) shall be taken as the maximum cardinal direction site wind speed ($V_{\text{sit},\beta}$) linearly interpolated between cardinal points within a sector $\pm 45^\circ$ to the orthogonal direction being considered (see Figures 2.2 and 2.3).

NOTE: That is, $V_{\text{des},\theta}$ equals the maximum value of site wind speed ($V_{\text{sit},\beta}$) in the range $[\beta = \theta \pm 45^\circ]$ where β is the cardinal direction clockwise from true North and θ is the angle to the building orthogonal axes.

In cases such as walls and hoardings and lattice towers, where an incident angle of 45° is considered, $V_{\text{des},\theta}$ shall be the maximum value of $V_{\text{sit},\beta}$ in a sector $\pm 22.5^\circ$ from the 45° direction being considered.

For ultimate state design, $V_{\text{des},\theta}$ shall be not less than 30 m/s for permanent structures (design life greater than 5 years), or less than 25 m/s for temporary structures (design life less than or equal to 5 years).

NOTE: A conservative approach is to design the structure using the wind speed and multipliers for the worst direction. For example, for a building on an escarpment it may be easily checked whether the $V_R M_d (M_{z,\text{cat}} M_s M_t)$ on the exposed face (towards the escarpment) is the worst case. To simplify design, this value could then be used as the design wind speed for all directions on the building.

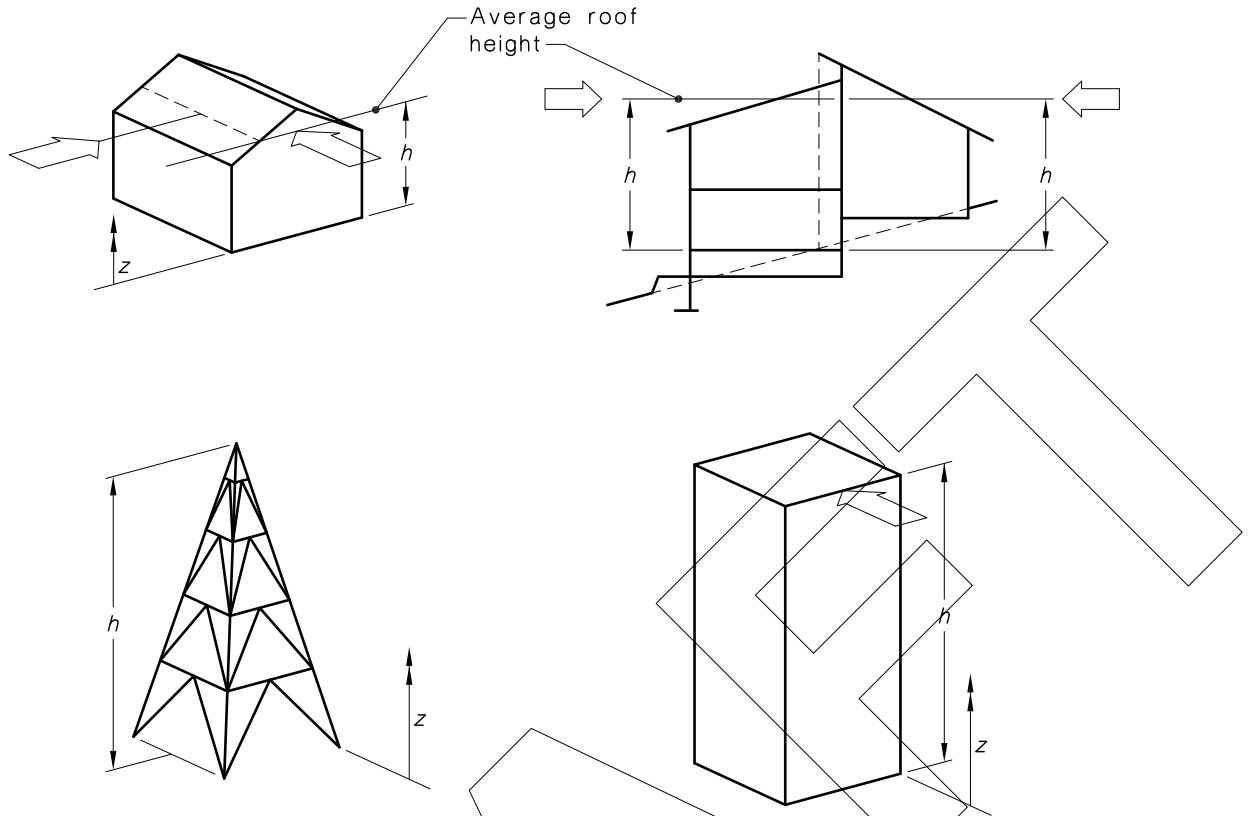

FIGURE 2.1 REFERENCE HEIGHT OF STRUCTURES

Licensed to Mr timothy Messer on 3 November 2009. Personal use licence only. Storage, distribution or use on network prohibited.

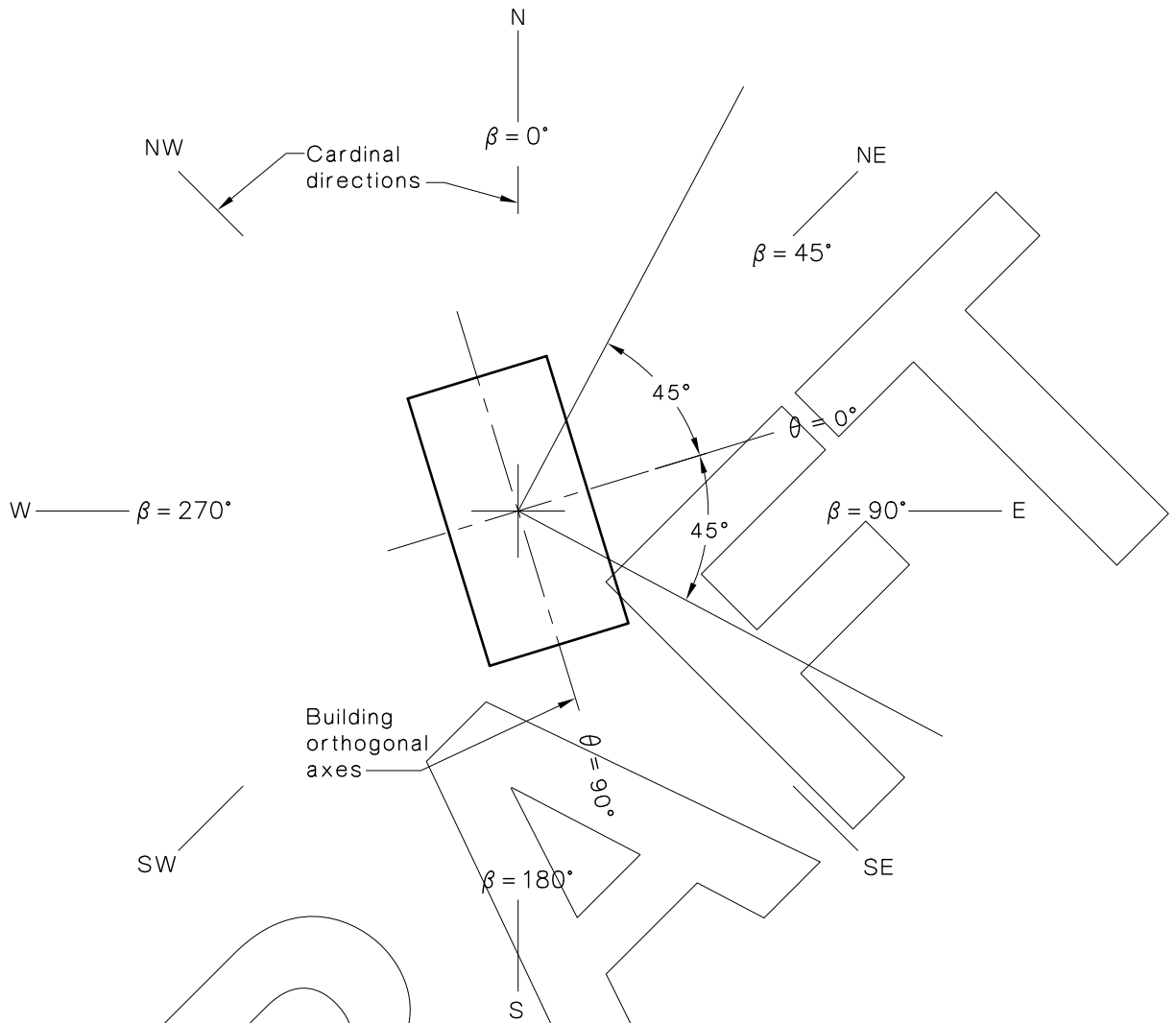
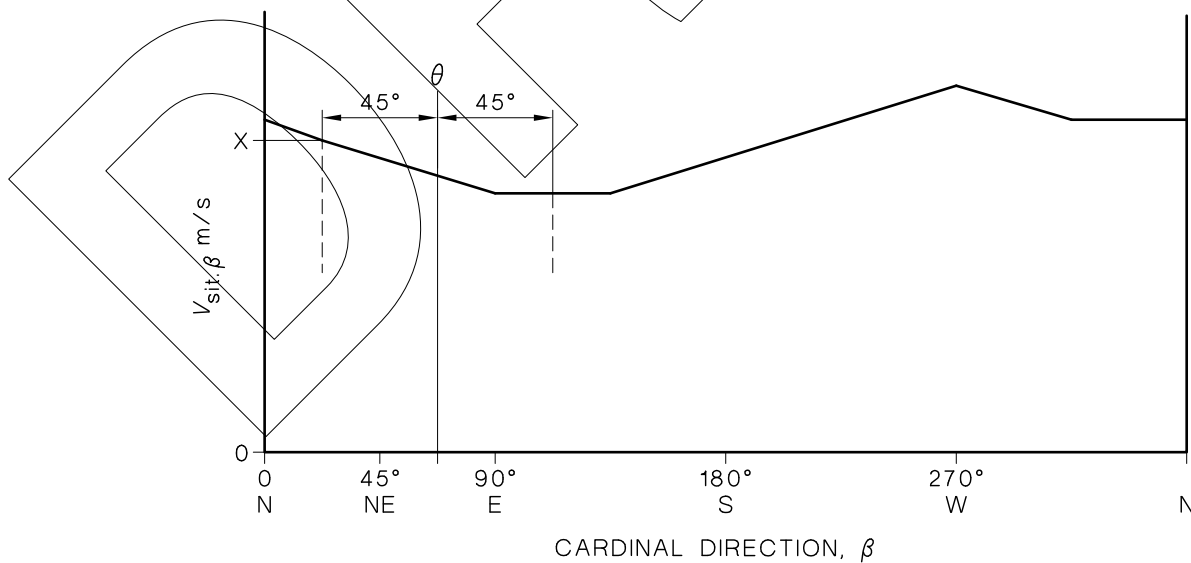

FIGURE 2.2 RELATIONSHIP OF WIND DIRECTIONS AND BUILDING ORTHOGONAL AXES



The value of $V_{des,\theta}$ is the maximum of $V_{sit,\beta}$ in the range $\theta \pm 45^\circ$, which, in the case shown here, is the wind speed X .

FIGURE 2.3 EXAMPLE OF $V_{sit,\beta}$ CONVERSION TO $V_{des,\theta}$

2.4 DESIGN WIND PRESSURE AND DISTRIBUTED FORCES

2.4.1 Design wind pressures

The design wind pressures (p), in pascals, shall be determined for structures and parts of structures as follows:

$$p = (0.5 \rho_{\text{air}}) [V_{\text{des},\theta}]^2 C_{\text{fig}} C_{\text{dyn}} \quad \dots 2.4(1)$$

where

p = design wind pressure in pascals

= p_e , p_i or p_n where the sign is given by the C_p values used to evaluate C_{fig}

NOTE: Pressures are taken as positive, indicating pressures above ambient and negative, indicating pressures below ambient.

ρ_{air} = density of air, which shall be taken as 1.2 kg/m^3

$V_{\text{des},\theta}$ = building orthogonal design wind speeds (usually, $\theta = 0^\circ, 90^\circ, 180^\circ$, and 270°), as given in Clause 2.3

NOTE: For some applications, $V_{\text{des},\theta}$ may be a single value or may be expressed as a function of height (z) e.g., windward walls of tall buildings (>25m).

C_{fig} = aerodynamic shape factor, as given in Section 5

C_{dyn} = dynamic response factor, as given in Section 6 [the value is 1.0 except where the structure is wind sensitive (see Section 6)]

2.4.2 Design frictional drag force per unit area

The design wind frictional drag force per unit area (f), in pascals, shall be taken for structures and parts of structures as follows:

$$f = (0.5 \rho_{\text{air}}) [V_{\text{des},\theta}]^2 C_{\text{fig}} C_{\text{dyn}} \quad \dots 2.4(2)$$

2.5 WIND ACTIONS

2.5.1 General

Wind actions (W_u and W_s) for use in AS/NZS 1170.0 shall be determined as given in Clauses 2.5.2 to 2.5.5 and accelerations as given in Clause 2.5.6.

2.5.2 Directions to be considered

Wind actions shall be derived by considering wind from no fewer than four orthogonal directions aligned to the structure.

2.5.3 Forces on surfaces or structural elements

2.5.3.1 Forces derived from wind pressure

To determine wind actions, the forces (F) in newtons, on surfaces or structural elements, such as a wall or a roof, shall be the vector sum of the forces calculated from the pressures applicable to the assumed areas (A), as follows:

$$F = \sum(p_z A_z) \quad \dots 2.5(1)$$

where

p_z = design wind pressure in pascals (normal to the surface) at height z , calculated in Clause 2.4.1

NOTE: The sign convention for pressures leads to forces towards the surface for positive pressures and forces away from the surface for negative pressures.

A_z = a reference area, in square metres, at height z , upon which the pressure at that height (p_z) acts.

For enclosed buildings, internal pressures shall be taken to act simultaneously with external pressures including the effects of local pressure factors (K_l).

NOTE: Generally, the most severe combinations of internal and external pressures shall be selected for design, but some reduction in the combined load may be applicable according to Clause 5.4.3.

Where it is required to divide the height of a tall structure into sectors to calculate wind actions {[for example, windward walls of tall buildings [Table 5.2(A)] or for lattice towers (Clause E4.1)]}, the sectors shall be of a size to represent reasonably the variation of wind speed with height, as given in Clause 4.2.

2.5.3.2 Force derived from frictional drag

To determine wind actions, the forces (F), in newtons, on a building element, such as a wall or a roof, shall be the vector sum of the forces calculated from distributed frictional drag stresses applicable to the assumed areas, as follows:

$$F = \sum(f_z A_z) \quad \dots 2.5(2)$$

where

f_z = design frictional drag per unit area parallel to the surface (calculated in Clause 2.4.2) at height z , in Pascals

A_z = a reference area, in square metres, on which the distributed frictional drag stresses (f_z) act

2.5.3.3 Forces derived from force coefficients

Appendices E and F cover structures for which shape factors are given in the form of force coefficients rather than pressure coefficients. In these cases, to determine wind actions, the forces (F) in newtons, shall be determined as follows:

$$F = (0.5 \rho_{\text{air}}) [V_{\text{des},\theta}]^2 C_{\text{fig}} C_{\text{dyn}} A_z \quad \dots 2.5(3)$$

where

A_z = as defined in Paragraph E4, Appendix E, for lattice towers

= $l \times b$ for members and simple sections in Paragraph E3, Appendix E

= A_{ref} as defined in Appendix F for flags and circular shapes

2.5.4 Forces and moments on complete structures

To determine wind actions, the total resultant forces and overturning moments on complete structures shall be taken to be the summation of the effects of the external pressures on all surfaces of the building.

For rectangular enclosed buildings with $h > 50$ m, torsion shall be applied, based on an eccentricity of $0.3b$ with respect to the centre of geometry of the building on the along-wind loading.

NOTE: For $d/b > 1.5$, the torsional moments are primarily generated by cross-wind forces and specialist advice should be sought.

For rectangular enclosed buildings where the ratio d/h or d/b (see Clause 5.4) is greater than 4, the total resultant force on a complete structure shall include the frictional drag calculated in accordance with Clause 5.5.

For dynamic effects, the combination of along-wind and crosswind responses shall be calculated in accordance with Section 6.

2.5.5 Performance of fatigue-sensitive elements

In regions C and D, cladding, its connections and immediate supporting members shall demonstrate performance under the pressure sequences defined in AS 4040.3 and the

Building Code of Australia, based on the ultimate limit state wind pressure on external and internal surfaces, as determined in accordance with this Standard.

2.5.6 Deflections of dynamically wind-sensitive structures

Wind actions for dynamically wind-sensitive structures (as defined in Clause 6.1) which may include chimneys, masts and poles of circular cross-section, shall be calculated in accordance with Section 6.

NOTE: Information on peak acceleration of other wind-sensitive structures is given in Appendix G.

2.5.7 Impact loading from windborne debris

Where windborne debris impact loading is specified, the debris resistance of the external building envelope (windows, doors and cladding) for the purposes of Clause 5.3.2 or the building envelope enclosing a shelter room shall be equivalent to—

- (a) a piece of timber with a cross section of 100 mm × 50 mm and a 4 kg mass impacting on at $0.4 V_R$ for horizontal trajectories and $0.1 V_R$ for vertical trajectories; and
- (b) five spherical steel balls 8 mm diameter (2 grams mass each) impacting at $0.4 V_R$ for horizontal trajectories and $0.3 V_R$ for vertical trajectories.

These impact loadings shall be applied independently in time and location.

SECTION 3 REGIONAL WIND SPEEDS

3.1 GENERAL

This Section shall be used to calculate gust wind speeds appropriate to the region in which a structure is to be constructed, including wind direction effects.

3.2 REGIONAL WIND SPEEDS (V_R)

Regional wind speeds (V_R) for all directions based on 3 second gust wind data shall be as given in Table 3.1 for the regions shown in Figure 3.1(A) and Figure 3.1(B) where R (average recurrence interval) is the inverse of the annual probability of exceedence of the wind speed for ultimate or serviceability limit states. Refer to the Building Code of Australia or AS/NZS 1170.0 for information on values of annual probability of exceedence appropriate for the design of structures).

The calculated value of V_R shall be rounded to the nearest 1 m/s.

TABLE 3.1
REGIONAL WIND SPEEDS

Regional wind speed (m/s)	Region				
	Non-cyclonic			Cyclonic	
	A (1 to 7)	W	B	C	D
V_1	30	34	26	23	23
V_5	32	39	28	33	35
V_{10}	34	41	33	39	43
V_{20}	37	43	38	45	51
V_{25}	37	43	39	47	53
V_{50}	39	45	44	$52 \times F_C$	$60 \times F_D$
V_{100}	41	47	48	$56 \times F_C$	$66 \times F_D$
V_{200}	43	49	52	$61 \times F_C$	$72 \times F_D$
V_{250}	43	49	53	$62 \times F_C$	$74 \times F_D$
V_{500}	45	51	57	$66 \times F_C$	$80 \times F_D$
V_{1000}	46	53	60	$70 \times F_C$	$85 \times F_D$
V_{2500}	48	55	64	$74 \times F_C$	$91 \times F_D$
V_{5000}	50	56	67	$78 \times F_C$	$95 \times F_D$
V_{10000}	51	58	69	$81 \times F_C$	$99 \times F_D$
$V_R (R \geq 5 \text{ years})$	$67-41R^{-0.1}$	$104-70R^{-0.045}$	$106-92R^{-0.1}$	$F_C (122-104R^{-0.1})$	$F_D (156-142R^{-0.1})$

NOTES:

- 1 Values for V_1 have not been calculated by the formula for V_R .
- 2 For ultimate or serviceability limit states, refer to the Building Code of Australia or AS/NZS 1170.0 for information on values of annual probability of exceedence appropriate for the design of structures.

3.3 WIND DIRECTION MULTIPLIER (M_d)

3.3.1 Regions A and W

The wind direction multiplier (M_d) for regions A and W shall be as given in Table 3.2.

3.3.2 Regions B, C and D

The wind direction multiplier (M_d) for all directions in regions B, C and D shall be as follows:

NOTE: Values for V_1 have not been calculated by the formula for V_R .

- (a) 0.95 for determining the resultant forces and overturning moments on complete buildings and wind actions on major structural elements.
- (b) 1.0 for all other cases (including cladding and immediate supporting members).

3.4 FACTORS FOR REGIONS C AND D (F_C , F_D)

The wind speeds given in Table 3.1 for regions C and D include additional factors (F_C and F_D) which shall be as follows:

- (a) For ultimate limit states wind speeds, $F_D = 1.1$.
- (b) For ultimate limit states wind speeds, $F_C = 1.05$.
- (c) For serviceability limit states wind speeds, F_C and $F_D = 1.0$.

NOTE: The factors in this Clause have been introduced to allow for uncertainties in the prediction of ultimate design wind speeds in Regions C and D (tropical cyclones regions). The values of these factors may be revised in the future following simulations based on recorded cyclone tracks. Such an analysis would naturally include cyclone activity throughout the northern coast of Australia (i.e., in regions C and D).

**TABLE 3.2
WIND DIRECTION MULTIPLIER (M_d)**

Cardinal directions	Region A1	Region A2	Region A3	Region A4	Region A5	Region A6	Region A7	Region W
N	0.90	0.80	0.85	0.90	1.00	0.85	0.90	1.00
NE	0.80	0.80	0.80	0.85	0.85	0.95	0.90	0.95
E	0.80	0.80	0.80	0.90	0.80	1.00	0.80	0.80
SE	0.80	0.95	0.80	0.90	0.80	0.95	0.90	0.90
S	0.85	0.90	0.80	0.95	0.85	0.85	0.90	1.00
SW	0.95	0.95	0.85	0.95	0.90	0.95	0.90	1.00
W	1.00	1.00	0.90	0.95	1.00	1.00	1.00	0.90
NW	0.95	0.95	1.00	0.90	0.95	0.95	1.00	0.95
Any direction	1.00	1.00	1.00	1.00	1.00	1.00	1.00	1.00

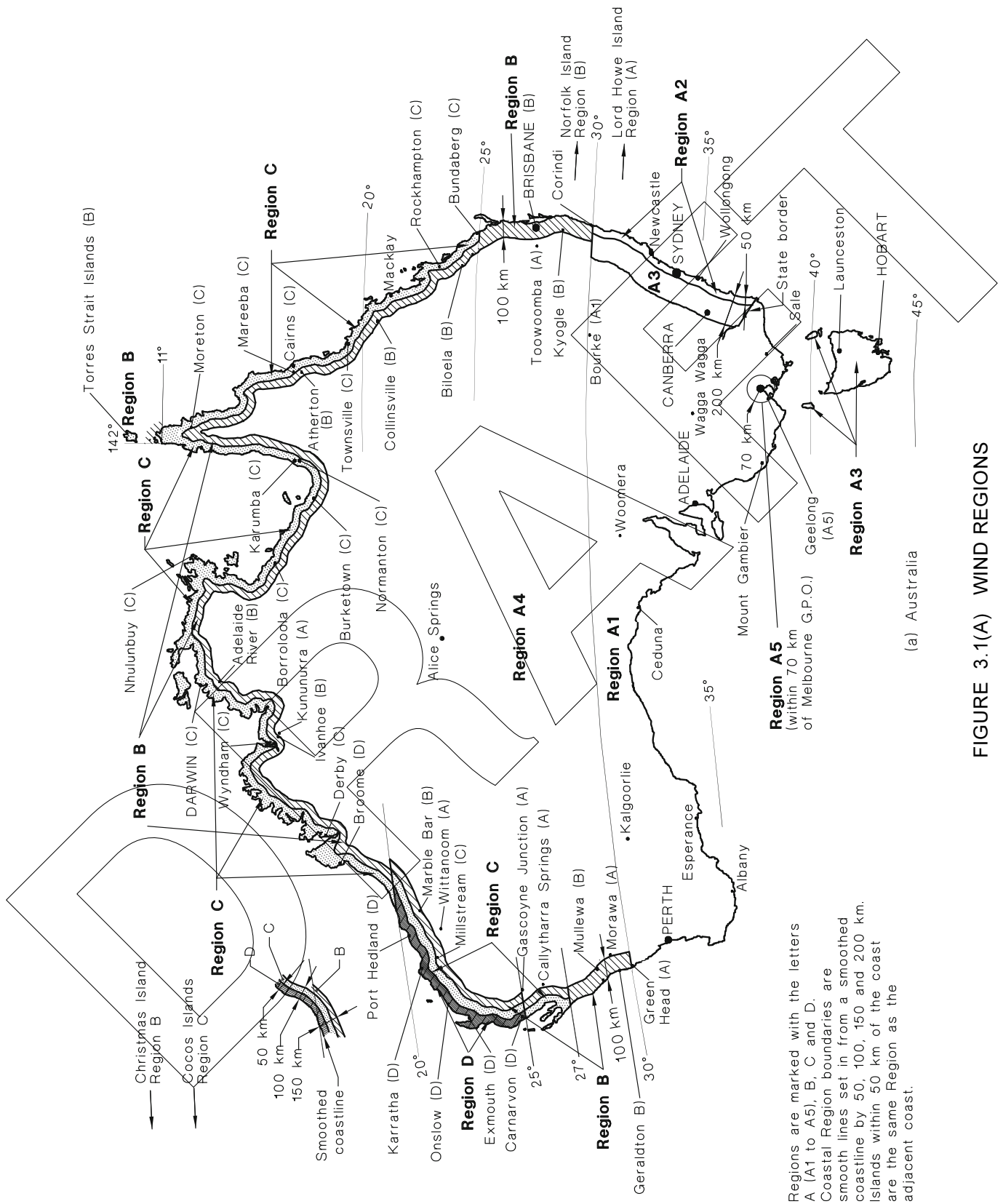

FIGURE 3.1(A) WIND REGIONS

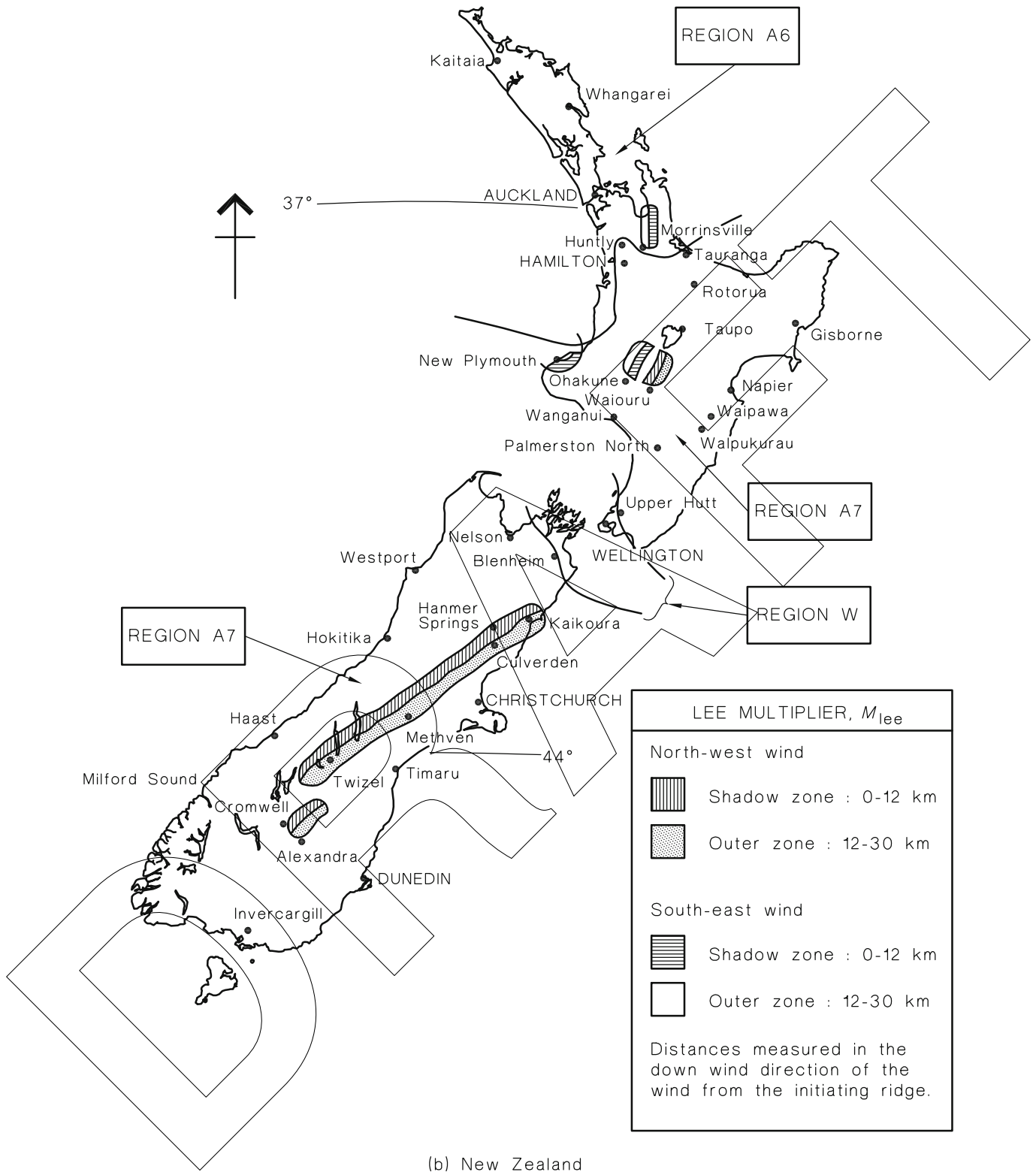

FIGURE 3.1(B) WIND REGIONS

Licensed to Mr timothy Messer on 3 November 2009. Personal use licence only. Storage, distribution or use on network prohibited.

SECTION 4 SITE EXPOSURE MULTIPLIERS

4.1 GENERAL

This Section shall be used to calculate the exposure multipliers relating to site conditions related to terrain/height ($M_{z,cat}$), shielding (M_s) and topography (M_t).

The design shall take account of known future changes to terrain roughness when assessing terrain category and to buildings providing shielding when assessing shielding.

4.2 TERRAIN/HEIGHT MULTIPLIER ($M_{z,cat}$)

4.2.1 Terrain category definitions

Terrain, over which the approach wind flows towards a structure, shall be assessed on the basis of the following category descriptions:

- (a) *Category 1*—Exposed open terrain with few or no obstructions and water surfaces at serviceability wind speeds.
- (b) *Category 2*—Water surfaces, open terrain, grassland with few, well-scattered obstructions having heights generally from 1.5 m to 10 m.
- (c) *Category 3*—Terrain with numerous closely spaced obstructions 3 m to 5 m high such as areas of suburban housing.
- (d) *Category 4*—Terrain with numerous large, high (10 m to 30 m high) and closely spaced obstructions such as large city centres and well-developed industrial complexes.

Selection of terrain category shall be made with due regard to the permanence of the obstructions that constitute the surface roughness. In particular, vegetation in tropical cyclonic regions shall not be relied upon to maintain surface roughness during wind events.

4.2.2 Determination of terrain/height multiplier ($M_{z,cat}$)

The variation with height (z) of the effect of terrain roughness on wind speed (terrain and structure height multiplier, $M_{z,cat}$) shall be taken from the values for fully developed profiles given in Tables 4.1(A) and 4.1(B). For intermediate values of height and terrain category, use linear interpolation.

TABLE 4.1(A)
TERRAIN/HEIGHT MULTIPLIERS FOR GUST WIND SPEEDS IN FULLY DEVELOPED TERRAINS—SERVICEABILITY LIMIT STATE DESIGN—ALL REGIONS AND ULTIMATE LIMIT STATE—REGIONS A1 TO A7, W AND B

Height (z) m	Terrain/height multiplier ($M_{z,cat}$)			
	Terrain category 1	Terrain category 2	Terrain category 3	Terrain category 4
≤3	0.99	0.91	0.83	0.75
5	1.05	0.91	0.83	0.75
10	1.12	1.00	0.83	0.75
15	1.16	1.05	0.89	0.75
20	1.19	1.08	0.94	0.75
30	1.22	1.12	1.00	0.80
40	1.24	1.16	1.04	0.85
50	1.25	1.18	1.07	0.90
75	1.27	1.22	1.12	0.98
100	1.29	1.24	1.16	1.03
150	1.31	1.27	1.21	1.11
200	1.32	1.29	1.24	1.16

NOTE: For intermediate values of height z and terrain category, use linear interpolation.

TABLE 4.1(B)
TERRAIN/HEIGHT MULTIPLIERS FOR GUST WIND SPEEDS IN FULLY DEVELOPED TERRAINS—ULTIMATE LIMIT STATE DESIGN—REGIONS C AND D ONLY

Height (z) m	Multiplier ($M_{z,cat}$)	
	Terrain categories 1 and 2	Terrain categories 3 and 4
≤3	0.90	0.80
5	0.95	0.80
10	1.00	0.89
15	1.07	0.95
20	1.13	1.05
30	1.20	1.15
40	1.25	1.25
50	1.29	1.29
75	1.35	1.35
≥100	1.40	1.40

NOTE: For intermediate values of height z and terrain category, use linear interpolation.

4.2.3 Changes in terrain category

When considering a direction where the wind approaches across ground with changes in terrain category that lie within the averaging distances given in Table 4.2(A) for structure height, the terrain and structure height multiplier ($M_{z,cat}$) shall be taken as the weighted average value over the averaging distance upwind of the structure at height z above ground level [see Figure 4.1(a)].

The weighted average of $M_{z,cat}$ shall be weighted by the length of each terrain upwind of the structure allowing for the lag distance at each terrain category change. An example is given in Figure 4.1(b).

For evaluation at height (z), a change in terrain incorporates a lag distance (x_i) given as follows:

$$x_i = z_{0,r} \left[\frac{z}{0.3z_{0,r}} \right]^{1.25} \dots 4.2$$

where

- x_i = distance downwind from the start of a new terrain roughness to the position where the developed height of the inner layer equals z (lag distance)
- $z_{0,r}$ = larger of the two roughness lengths at a boundary between roughnesses, as given in Table 4.2(B)
- z = reference height on the structure above the average local ground level

TABLE 4.2(A)
AVERAGING DISTANCE FOR STRUCTURE HEIGHT

Structure height (m)	Averaging distance upwind of structure (m)
$h < 50$	1000
$50 \leq h < 100$	2000
$100 \leq h \leq 200$	3000

TABLE 4.2(B)
ROUGHNESS LENGTHS FOR TERRAIN CATEGORIES

Terrain category	Roughness length (m)
1	0.002
2	0.02
3	0.2
4	2.0

Licensed to Mr timothy Messer on 3 November 2009. Personal use licence only. Storage, distribution or use on network prohibited.

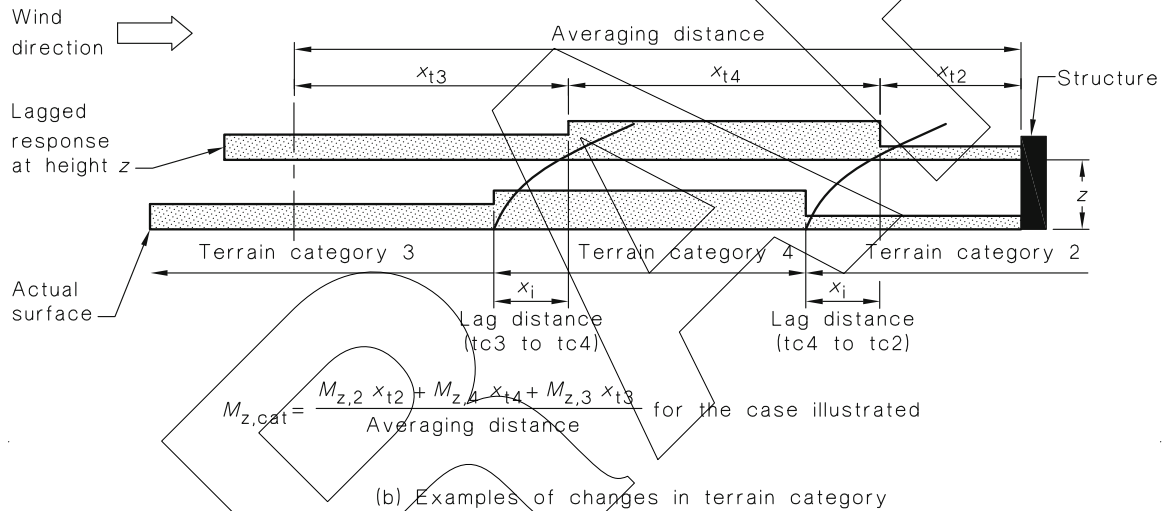
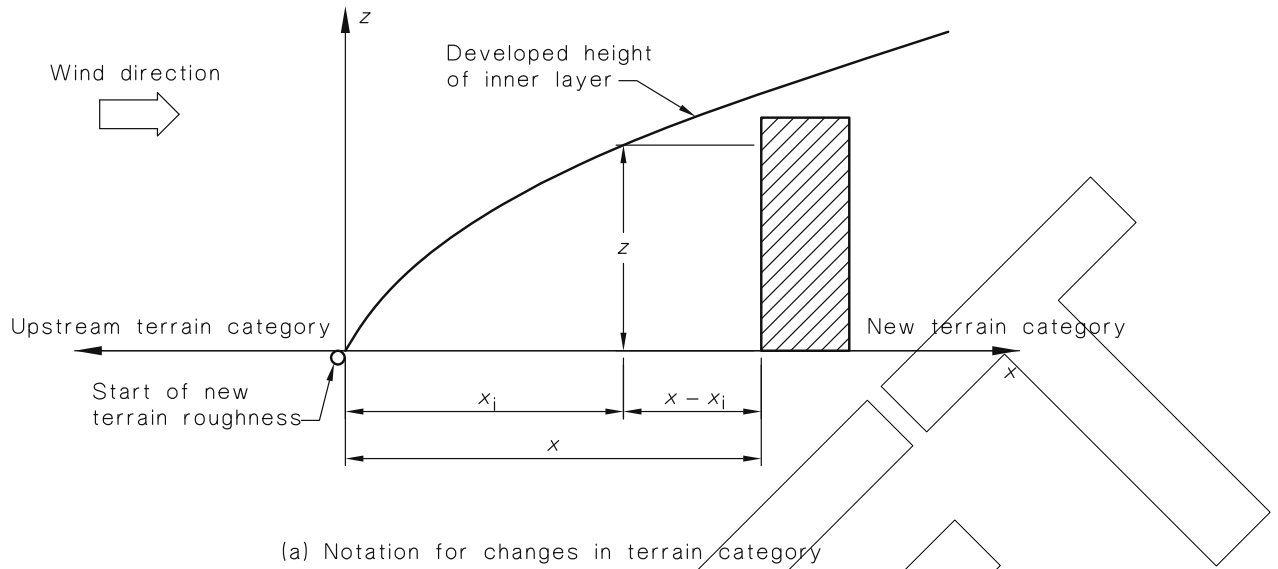

FIGURE 4.1 CHANGES IN TERRAIN CATEGORY

4.3 SHIELDING MULTIPLIER (M_s)

4.3.1 General

Shielding may be provided by upwind buildings or other structures. Shielding from trees or vegetation is not permitted in this Standard.

The shielding multiplier (M_s) that is appropriate to a particular direction shall be as given in Table 4.3. The shielding multiplier shall be 1.0 where the average upwind ground gradient is greater than 0.2 or where the effects of shielding are not applicable for a particular wind direction or are ignored.

Attention shall be given to possible combinations of tall buildings placed together, which lead to local and overall increases in wind actions (see AS/NZS 1170.2 Supp 1).

TABLE 4.3
SHIELDING MULTIPLIER (M_s)

Shielding parameter (s)	Shielding multiplier (M_s)
≤1.5	0.7
3.0	0.8
6.0	0.9
≥12.0	1.0

NOTE: For intermediate values of s , use linear interpolation.

4.3.2 Buildings providing shielding

Only buildings within a 45° sector of radius $20h$ (symmetrically positioned about the directions being considered) and whose height is greater than or equal to z shall be deemed to provide shielding.

4.3.3 Shielding parameter (s)

The shielding parameter (s) in Table 4.3 shall be determined as follows:

$$s = \frac{l_s}{\sqrt{h_s b_s}} \quad \dots 4.3(1)$$

where

l_s = average spacing of shielding buildings, given by:

$$= h \left(\frac{10}{n_s} + 5 \right) \quad \dots 4.3(2)$$

h_s = average roof height of shielding buildings

b_s = average breadth of shielding buildings, normal to the wind stream

h = average roof height, above ground, of the structure being shielded

n_s = number of upwind shielding buildings within a 45° sector of radius $20h$ and with $h_s \geq z$

4.4 TOPOGRAPHIC MULTIPLIER (M_t)

4.4.1 General

The topographic multiplier (M_t) shall be taken as follows:

- (a) For sites in New Zealand and Tasmania over 500 m above sea level:

$$M_t = M_h M_{lee} (1 + 0.00015 E) \quad \dots 4.4(1)$$

where

M_h = hill shape multiplier

M_{lee} = lee (effect) multiplier (taken as 1.0, except in New Zealand lee zones, see Clause 4.4.3)

E = site elevation above mean sea level, in metres

- (b) Elsewhere, the larger value of the following:

- (i) $M_t = M_h$

- (ii) $M_t = M_{lee}$

4.4.2 Hill-shape multiplier (M_h)

The hill shape multiplier (M_h) shall be assessed for each cardinal direction considered, taking into account the most adverse topographic cross-section that occurs within the range of directions within 22.5° on either side of the cardinal direction being considered. The value shall be as follows:

- (a) For $H/(2L_u) < 0.05$, $M_h = 1.0$
- (b) For $0.05 \leq H/(2L_u) \leq 0.45$ (see Figures 4.2 and 4.3):

$$M_h = 1 + \left(\frac{H}{3.5(z + L_1)} \right) \left(1 - \frac{|x|}{L_2} \right) \dots 4.4(2)$$

- (c) For $H/(2L_u) > 0.45$ (see Figure 4.4):
 - (i) Within the separation zone (see Figure 4.4)

$$M_h = 1 + 0.71 \left[1 - \frac{|x|}{L_2} \right] \dots 4.4(3)$$

- (ii) Elsewhere within the local topographic zone (see Figures 4.2 and 4.3), M_h shall be as given in Equation 4.4(2)

where

- H = height of the hill, ridge or escarpment
- L_u = horizontal distance upwind from the crest of the hill, ridge or escarpment to a level half the height below the crest
- x = horizontal distance upwind or downwind of the structure to the crest of the hill, ridge or escarpment
- L_1 = length scale, to determine the vertical variation of M_h , to be taken as the greater of $0.36 L_u$ or $0.4 H$
- L_2 = length scale, to determine the horizontal variation of M_h , to be taken as $4 L_1$ upwind for all types, and downwind for hills and ridges, or $10 L_1$ downwind for escarpments
- z = reference height on the structure above the average local ground level

NOTE: Figures 4.2, 4.3 and 4.4 are cross-sections through the structure's site for a particular wind direction.

For the case where x and z are zero, the value of M_h is given in Table 4.4.

Irrespective of the provisions of this Clause, the influence of any peak may be ignored, provided it is distant from the site of the structure by more than 10 times its elevation above sea level.

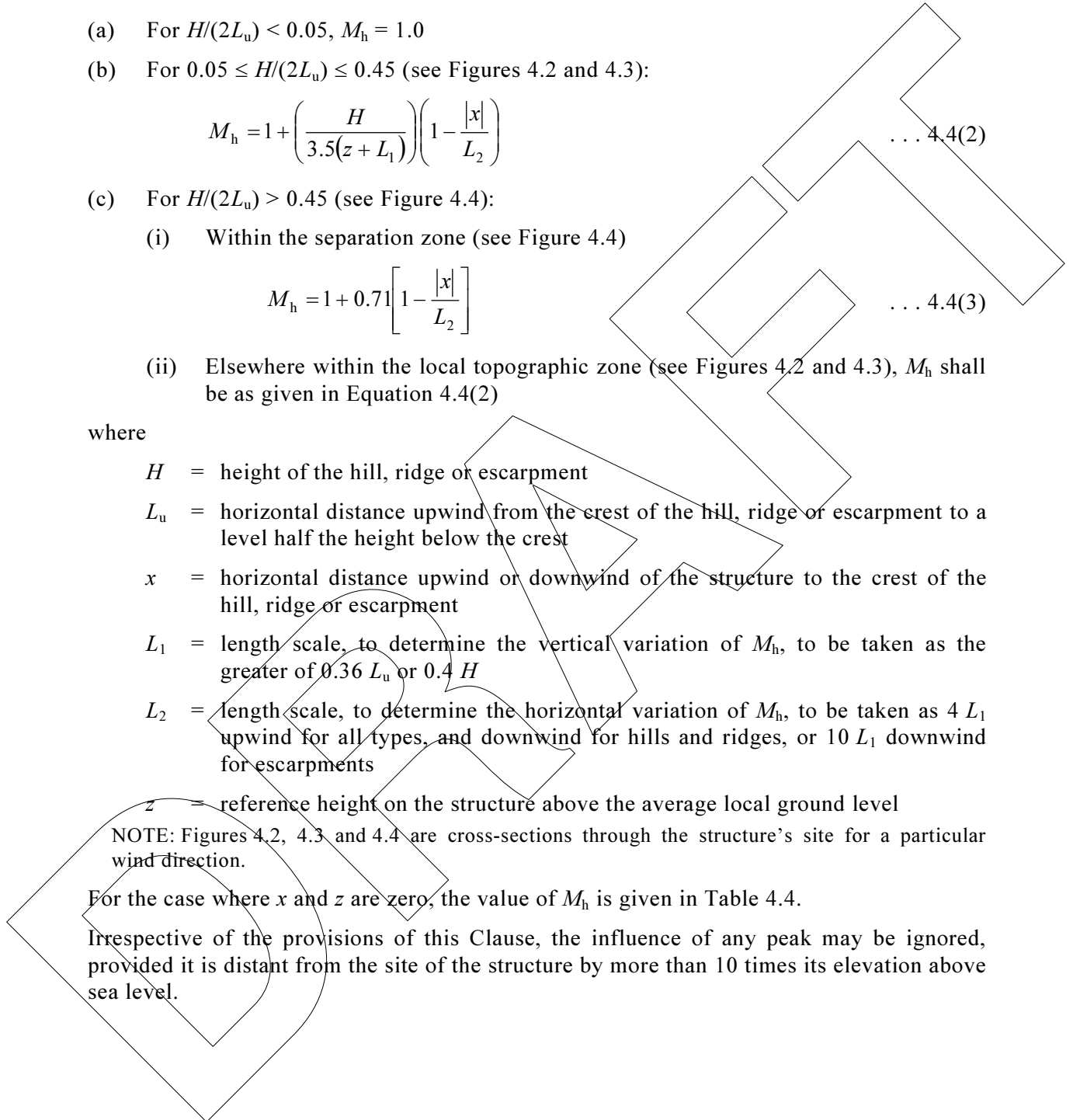

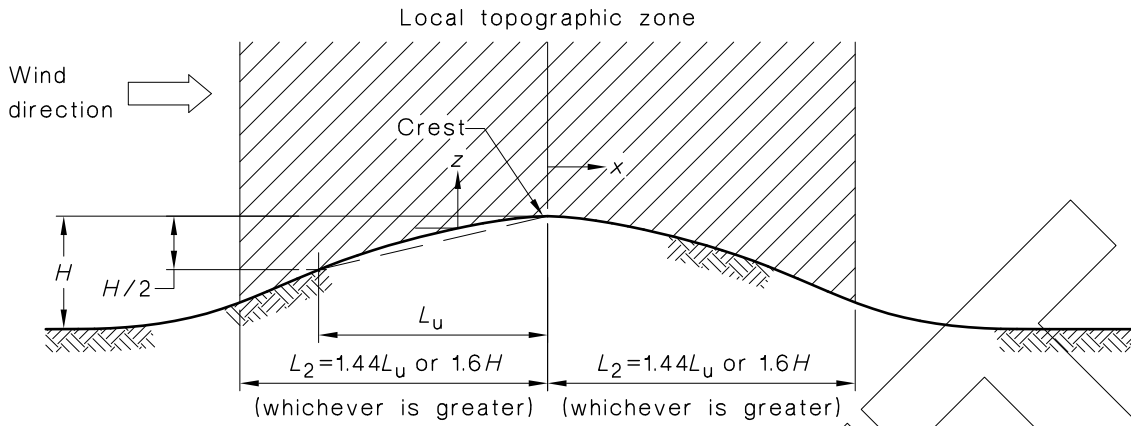
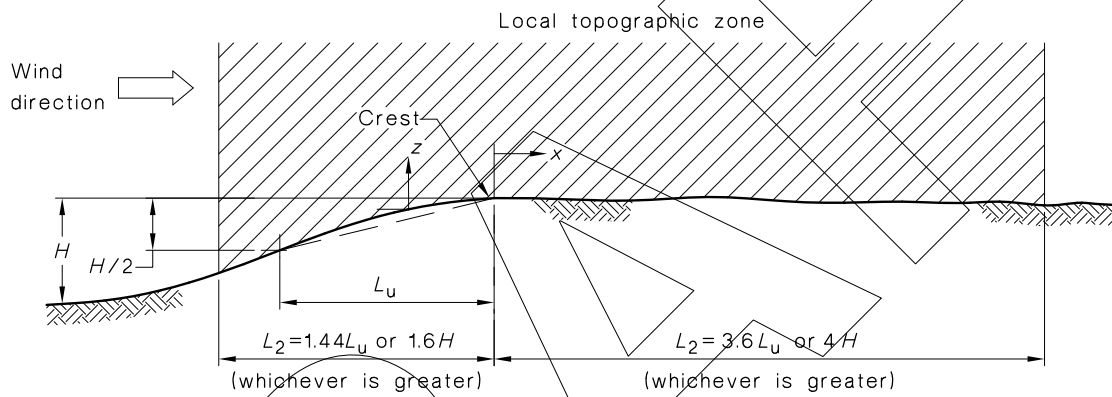

FIGURE 4.2 HILLS AND RIDGES



NOTE: For escarpments, the average downwind slope, measured from the crest to a distance of the greater of $3.6 L_u$ or $4 H$ shall not exceed 0.05.

FIGURE 4.3 ESCARPMENTS

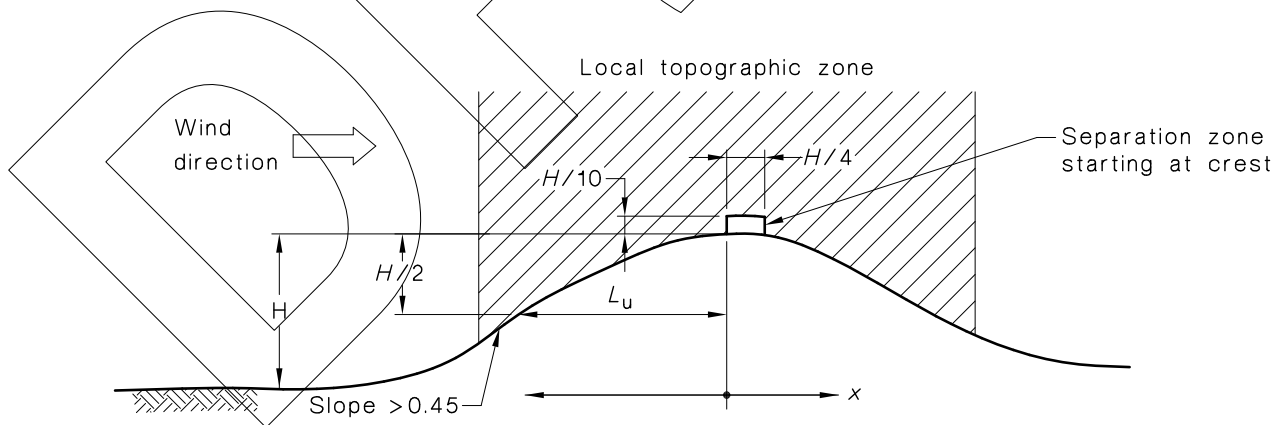

FIGURE 4.4 SEPARATION ZONE FOR HILLS AND ESCARPMENTS HAVING UPWIND SLOPES GREATER THAN 0.45

Licensed to Mr timothy Messer on 3 November 2009. Personal use licence only. Storage, distribution or use on network prohibited.

TABLE 4.4
HILL-SHAPE MULTIPLIER AT CREST
($|x| = 0$), $z = 0$ (FOR GUST WIND SPEEDS)

Upwind slope ($H/2L_w$)	M_h
<0.05	1.0
0.05	1.08
0.10	1.16
0.20	1.32
0.30	1.48
≥0.45	1.71

4.4.3 Lee multiplier (M_{lee})

The lee (effect) multiplier (M_{lee}) shall be evaluated for New Zealand sites in the lee zones as shown in Figure 3.1(b). For all other sites, the lee multiplier shall be 1.0. Within the lee zones, the lee multiplier shall apply only to wind from the cardinal directions nominated in Figure 3.1(b).

Each lee zone shall be 30 km in width, measured from the leeward crest of the initiating range, downwind in the direction of the wind nominated. The lee zone comprises a 'shadow lee zone', which extends 12 km from the upwind boundary of the lee zone (crest of the initiating range), and an 'outer lee zone' over the remaining 18 km.

The lee multiplier shall be 1.35 for sites within the shadow lee zone (i.e., within 12 km of the crest of the range). Within the outer lee zone, the lee multiplier shall be determined by linear interpolation with horizontal distance, from the shadow/outer zone boundary (where $M_{lee} = 1.35$), to the downwind lee zone boundary (where $M_{lee} = 1.0$).

NOTE: No lee zones have been identified in Australia.

SECTION 5 AERODYNAMIC SHAPE FACTOR

5.1 GENERAL

This Section shall be used to calculate the aerodynamic shape factor (C_{fig}) for structures or parts of structures. Values of C_{fig} shall be used in determining the pressures applied to each surface. For calculating pressures, the sign of C_{fig} indicates the direction of the pressure on the surface or element (see Figure 5.1), positive values indicating pressure acting towards the surface and negative values pressure acting away from the surface (less than ambient pressure, i.e., suction). The wind action effects used for design shall be the sum of values determined for different pressure effects such as the combination of internal and external pressure on enclosed buildings.

Clauses 5.3, 5.4 and 5.5 provide values for enclosed rectangular buildings. For the purposes of this Standard, rectangular buildings includes buildings generally made up of rectangular shapes in plan. Methods for other types of enclosed buildings, exposed members, lattice towers, free walls, free roofs and other structures are given in the appropriate Appendices, C to F.

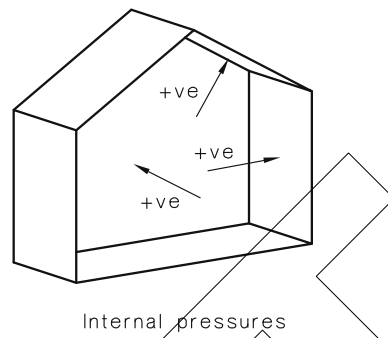
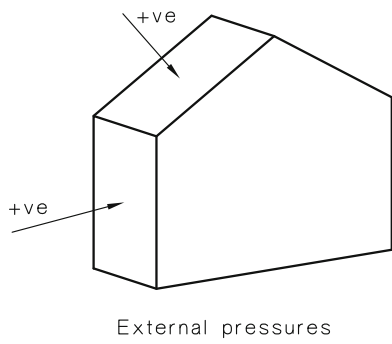

NOTE: C_{fig} is used to give a pressure on one face of the surface under consideration. Positive value of C_{fig} indicates pressure acting towards the surface, negative acting away from the surface.

(a) Pressures normal to the surfaces of enclosed buildings

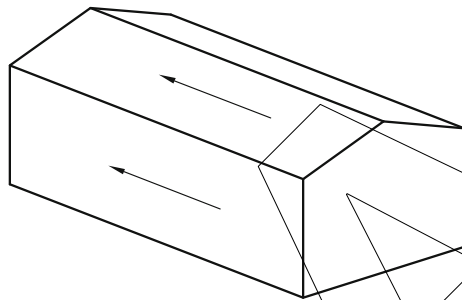

NOTE: C_{fig} is used to give a frictional drag on external surfaces of the structure only. Load per unit area acts parallel to the surface.

(b) Frictional drag on enclosed buildings

FIGURE 5.1 (in part) SIGN CONVENTIONS FOR C_{fig}

Licensed to Mr Timothy Messer on 3 November 2009. Personal use licence only. Storage, distribution or use on network prohibited.

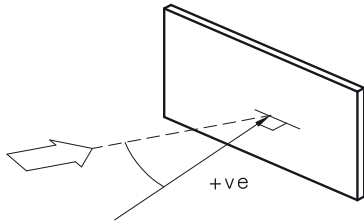

NOTE: C_{fig} is used to give a net pressure normal to the wall derived from face pressures on both upwind and downwind faces. The net pressure always acts normal to the longitudinal axis of the wall.

(c) Pressure normal to the surfaces of walls and hoardings

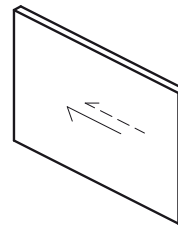

NOTE: C_{fig} is used to give frictional drag on both sides of the wall. Load per unit area acts parallel to both the surfaces of the wall.

(d) Frictional drag on walls and hoardings

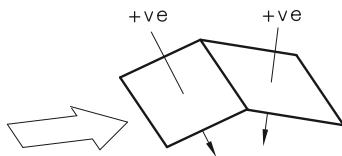

NOTE: C_{fig} is used to give net pressure normal to the roof derived from face pressures on both upper and lower surfaces. The net pressure always acts normal to the surface and positive indicates downwards.

(e) Pressure normal to the surfaces freestanding roofs

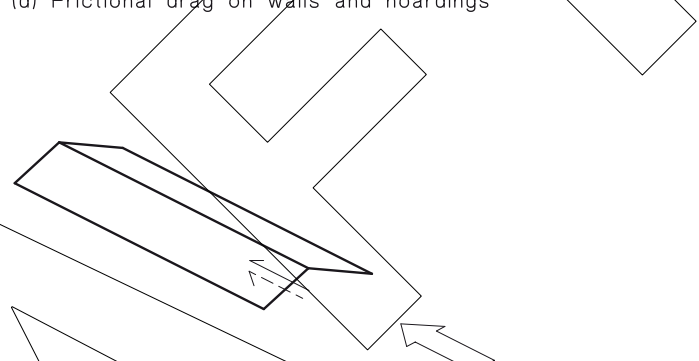

NOTE: C_{fig} is used to give the total frictional drag forces derived from face frictional forces on both upper and lower surfaces. Load per unit area acts parallel to both the surfaces of the roof.

(f) Frictional drag on freestanding roofs

FIGURE 5.1 (in part) SIGN CONVENTIONS FOR C_{fig}

5.2 EVALUATION OF AERODYNAMIC SHAPE FACTOR

The aerodynamic shape factor (C_{fig}) shall be determined for specific surfaces or parts of surfaces as follows:

(a) *Enclosed buildings (see this Section 5 and Appendix C):*

$$C_{fig,i} = C_{p,i} K_{c,i}, \text{ for internal pressures} \quad \dots 5.2(1)$$

$$C_{fig,e} = C_{p,e} K_a K_{c,e} K_l K_p, \text{ for external pressures} \quad \dots 5.2(2)$$

$$C_{fig} = C_f K_a K_c, \text{ for frictional drag forces} \quad \dots 5.2(3)$$

(b) *Circular bins, silos and tanks*—see Appendix C.

(c) *Freestanding walls, hoardings, canopies and roofs (see Appendix D):*

$$C_{fig} = C_{p,n} K_a K_l K_p, \text{ for pressure normal to surface} \quad \dots 5.2(4)$$

$$C_{fig} = C_f, \text{ for frictional drag forces} \quad \dots 5.2(5)$$

(d) *Exposed structural members, frames and lattice towers*—see Appendix E.

(e) *Flags and circular shapes*—see Appendix F.

where

$C_{p,e}$ = external pressure coefficient

$C_{p,i}$ = internal pressure coefficient

C_f = frictional drag force coefficient

$C_{p,n}$ = net pressure coefficient acting normal to the surface for canopies, freestanding roofs, walls, and the like

K_a = area reduction factor

K_c = combination factor

$K_{c,e}$ = combination factor applied to external pressures

$K_{c,i}$ = combination factor applied to internal pressures

K_l = local pressure factor

K_p = porous cladding reduction factor

5.3 INTERNAL PRESSURE FOR ENCLOSED RECTANGULAR BUILDINGS

5.3.1 General

Aerodynamic shape factors for internal pressure ($C_{p,i}$) shall be determined from Tables 5.1(A) and 5.1(B). Table 5.1(A) shall be used for the design case where potential openings are shut and the wall permeability dominates. Table 5.1(B) shall be used for the design case where openings are assumed to be open. In all cases, the height at which the wind speed is determined shall be the average roof height (h), as defined in Figure 2.1.

Internal pressure is a function of the relative permeability of the external surfaces of the building. The permeability of a surface shall be calculated by adding areas of opening to leakage on that surface of the building (e.g., vents, gaps in windows).

5.3.2 Openings

Combinations of openings shall be assumed to give internal pressures, which together with external pressures give the most adverse wind actions. Potential openings include doors, windows and vents. Closed doors (including roller doors) and windows shall be considered to be openings unless they are capable of resisting the applied wind pressures in all regions (and impact loading from wind-borne debris in Regions C and D). This structural assessment shall include elements such as supports, frames, jambs, roller door guides, windlocks and fixings where the resistance of roller doors relies on those. This assessment shall account for any catenary actions developed and relied upon in the structure. Garage doors shall be designed and constructed in accordance with AS/NZS 4505, as a minimum requirement.

In Regions C and D, internal pressure resulting from the dominant opening shall be applied, unless the building envelope (windows, doors and cladding at heights up to 25 m) can be shown to be capable of resisting impact loading from windborne debris determined in accordance with Clause 2.5.7.

5.3.3 Dominant openings

A surface is considered to contain dominant openings if the sum of the areas of all openings in that surface exceeds the sum of the areas of the openings in each of the other surfaces with pressures of opposite sign considered one at a time.

NOTE: A dominant opening does not need to be large and can occur as a result of a particular proposed scenario, such as an open air vent, while all other potential openings are shut.

5.3.4 Internal walls and partitions

This Clause applies to wind actions on internal walls and partitions that provide a permanent and effective seal between the spaces on either side of the wall. This includes inter-tenancy walls. Differential wind pressures across such internal walls or partitions shall be considered in design when there is a potential for either or both sides to be exposed to different wind pressures resulting from openings on, or permeability of, the exterior building envelope.

TABLE 5.1(A)
INTERNAL PRESSURE COEFFICIENTS ($C_{p,i}$) FOR BUILDINGS WITH OPEN INTERIOR PLAN—CASES FOR PERMEABLE WALLS WITHOUT DOMINANT OPENINGS

Condition	$C_{p,i}$	Examples showing openings, permeability and wind direction
One wall permeable, other walls impermeable: (a) Windward wall permeable (b) Windward wall impermeable	0.6 -0.3	
Two or three walls equally permeable, other walls impermeable: (a) Windward wall permeable (b) Windward wall impermeable	-0.1, 0.2 -0.3	
All walls equally permeable	-0.3 or 0.0, whichever is the more severe for combined forces	
A building effectively sealed and having non-opening windows	-0.2 or 0.0, whichever is the more severe for combined forces	

TABLE 5.1(B)
INTERNAL PRESSURE COEFFICIENTS ($C_{p,i}$) FOR BUILDINGS WITH OPEN INTERIOR PLAN—DOMINANT OPENINGS ON ONE SURFACE

Ratio of dominant opening to total open area (including permeability) of other wall and roof surfaces	Dominant opening on windward wall	Dominant opening on leeward wall	Dominant opening on side wall	Dominant opening on roof
0.5 or less	-0.3, 0.0	-0.3, 0.0	-0.3, 0.0	-0.3, 0.0
1	-0.1, 0.2	-0.3, 0.0	-0.3, 0.0	-0.3, 0.0
2	$0.7C_{p,e}$	$1.3C_{p,e}$	$C_{p,e}$	$C_{p,e}$
3	$0.85C_{p,e}$	$1.1C_{p,e}$	$C_{p,e}$	$C_{p,e}$
6 or more	$C_{p,e}$	$C_{p,e}$	$C_{p,e}$	$C_{p,e}$

NOTE: $C_{p,e}$ is the relevant external pressure coefficient at the location of the dominant opening.

Licensed to Mr Timothy Messer on 3 November 2009. Personal use licence only. Storage, distribution or use on network prohibited.

5.4 EXTERNAL PRESSURES FOR ENCLOSED RECTANGULAR BUILDINGS

5.4.1 External pressure coefficients ($C_{p,e}$)

The external pressure coefficients ($C_{p,e}$) for surfaces of rectangular enclosed buildings shall be as given in Tables 5.2(A), 5.2(B) and 5.2(C) for walls and 5.3(A), 5.3(B) and 5.3(C) for roofs and for some special roofs Appendix C. The parameters (e.g. dimensions) referred to in these Tables are set out in Figure 5.2.

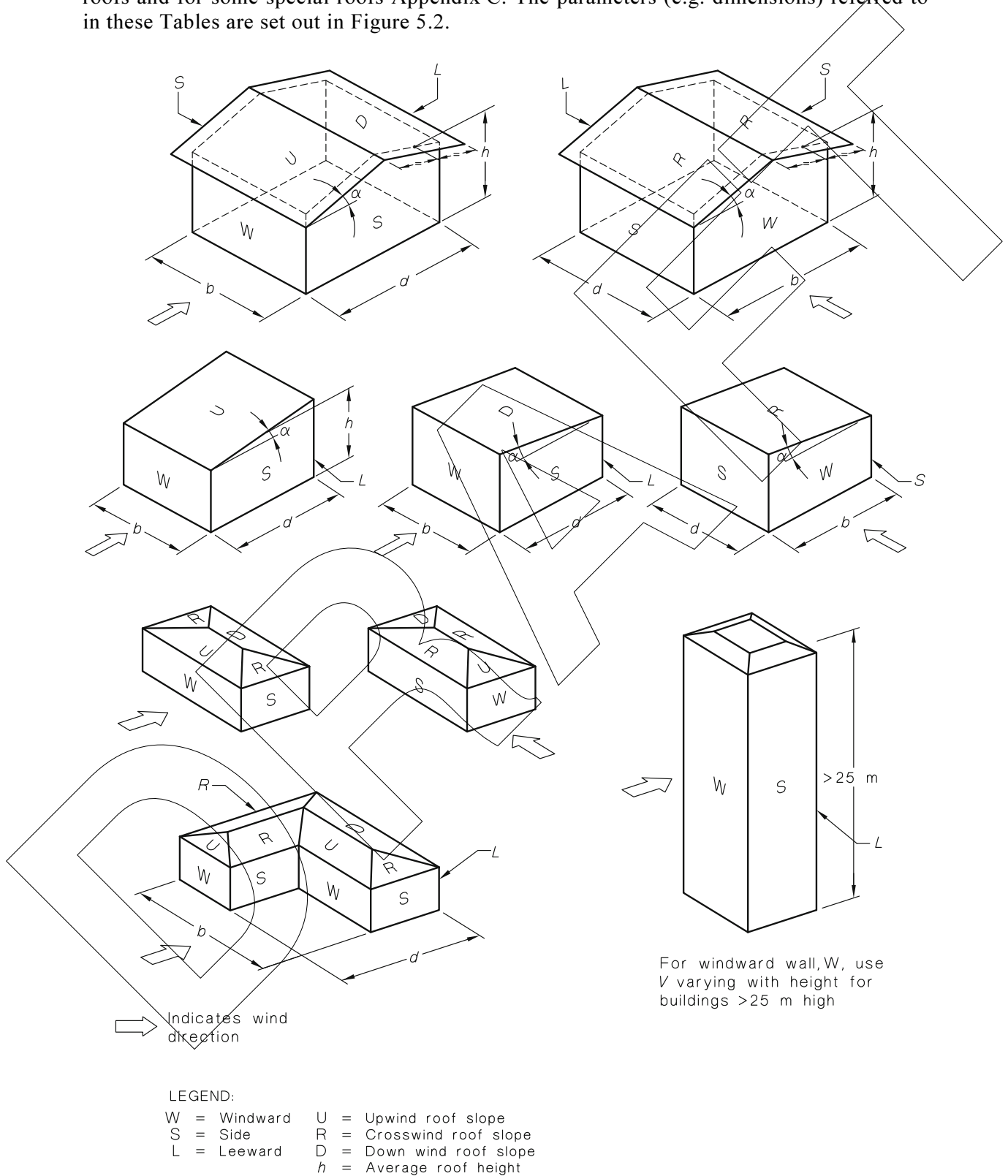

FIGURE 5.2 PARAMETERS FOR RECTANGULAR ENCLOSED BUILDINGS

For leeward walls, side walls and roofs, wind speed shall be taken as the value at $z = h$. The reference height (h) shall be taken as the average height of the roof.

Where two values of $C_{p,e}$ are listed, roofs shall be designed for both values. In these cases, roof surfaces may be subjected to either value due to turbulence. Alternative combinations of external and internal pressures (see also Clause 5.3) shall be considered, to obtain the most severe conditions for design.

For roofs, the following alternative load cases shall be considered:

- (a) When using Table 5.3(A), for the appropriate roof type, slope and edge distance—
 - (i) apply the more negative value of $C_{p,e}$ to all pressure zones and surfaces; and
 - (ii) apply the less negative (or most positive) value of $C_{p,e}$ to all pressure zones and surfaces.
- (b) When using both Tables 5.3(B) and 5.3(C), and for the appropriate parameters—
 - (i) apply the more negative value of $C_{p,e}$ from Table 5.3(B) to the upwind slope together with the value from Table 5.3(C) to the downwind slope; and
 - (ii) apply the less negative (or positive) value of $C_{p,e}$ from Table 5.3(B) to the upwind slope together with the value from Table 5.3(C) to the downwind slope.
- (c) When using Table 5.3(C) only, for steeper crosswind slopes on hip roofs, apply the appropriate $C_{p,e}$ value to both slopes.

For the underside of elevated buildings, $C_{p,e}$ shall be taken as 0.8 and -0.6 . For buildings with less elevation above ground than one-third of the height, use linear interpolation between these values and 0.0, according to the ratio of clear unvalled height underneath first floor level to the total building height. For the calculation of underside external pressures, wind speed shall be taken as the value at h for all z .

Under-eaves pressures shall be taken as equal to those applied to the adjacent wall surface below the surface under consideration.

TABLE 5.2(A)
WALLS—EXTERNAL PRESSURE COEFFICIENTS ($C_{p,e}$) FOR
RECTANGULAR ENCLOSED BUILDINGS—WINDWARD WALL (W)

h	External pressure coefficients ($C_{p,e}$)
>25.0 m	0.8 (wind speed varies with height)
≤ 25.0 m	For buildings on ground—
	0.8, when wind speed varies with height; or
	0.7, when wind speed is taken for $z = h$
	For elevated buildings—
	0.8 (wind speed taken at h)

TABLE 5.2(B)
WALLS—EXTERNAL PRESSURE COEFFICIENTS ($C_{p,e}$) FOR
RECTANGULAR ENCLOSED BUILDINGS—LEEWARD WALL (L)

Wind direction θ degrees (see Figure 2.2)	Roof shape	Roof pitch (α), degrees (see Note 1)	d/b (see Note 1)	External pressure coefficients ($C_{p,e}$)
0	Hip or gable	<10	≤ 1	-0.5
			2	-0.3
			≤ 4	-0.2
0	Hip or gable	10	All values	-0.3
	Hip or gable	15		-0.3
	Hip or gable	20		-0.4
0	Hip or gable	≥ 25	≤ 0.1	-0.75
			≥ 0.3	-0.5
90	Gable (see Note 2)	All values	≤ 1	-0.5
			2	-0.3
			≤ 4	-0.2

NOTES:

- 1 For intermediate values of d/b and α , linear interpolation shall be used.
- 2 For hip roofs use the same values as for $\theta = 0^\circ$.

TABLE 5.2(C)
WALLS—EXTERNAL PRESSURE COEFFICIENTS ($C_{p,e}$) FOR
RECTANGULAR ENCLOSED BUILDINGS—SIDE WALLS (S)

Horizontal distance from windward edge	External pressure coefficients ($C_{p,e}$)
0 to $1h$	-0.65
$1h$ to $2h$	-0.5
$2h$ to $3h$	-0.3
$> 3h$	-0.2

TABLE 5.3(A)
ROOFS—EXTERNAL PRESSURE COEFFICIENTS ($C_{p,e}$) FOR
RECTANGULAR ENCLOSED BUILDINGS—FOR UPWIND SLOPE (U), AND
DOWNWIND SLOPE (D) AND (R) FOR GABLE ROOFS, FOR $\alpha < 10^\circ$

Roof type and slope		Horizontal distance from windward edge of roof	External pressure coefficient ($C_{p,e}$)	
Crosswind slopes for gable roofs, (R)	Upwind slope, (U), Downwind slope, (D)		$h/d \leq 0.5$ (see Note 1)	$h/d \geq 1.0$ (see Note 1)
All α	$\alpha < 10^\circ$	0 to $0.5h$	-0.9, -0.4	-1.3, -0.6
		0.5 to $1h$	-0.9, -0.4	-0.7, -0.3
		$1h$ to $2h$	-0.5, 0	(-0.7), (-0.3)
		$2h$ to $3h$	-0.3, 0.1	see Note 2
		$> 3h$	-0.2, 0.2	

NOTES:

- 1 For intermediate values of roof slopes and h/d ratios, linear interpolation shall be used. Interpolation shall only be carried out on values of the same sign.
- 2 The values given in parentheses are provided for interpolation purposes.

TABLE 5.3(B)
ROOFS—EXTERNAL PRESSURE COEFFICIENTS ($C_{p,e}$) FOR
RECTANGULAR ENCLOSED BUILDINGS—UPWIND SLOPE (U) $\alpha \geq 10^\circ$

Upwind slope, (U)	Ratio h/d (see Note)	External pressure coefficients ($C_{p,e}$)						
		Roof pitch (α) degrees (see Note)						
		10	15	20	25	30	35	≥ 45
$\alpha \geq 10^\circ$	≤ 0.25	-0.7, -0.3	-0.5, 0.0	-0.3, 0.2	-0.2, 0.3	-0.2, 0.4	0.0, 0.5	0, $0.8 \sin \alpha$
	0.5	-0.9, -0.4	-0.7, -0.3	-0.4, 0.0	-0.3, 0.2	-0.2, 0.3	-0.2, 0.4	
	≥ 1.0	-1.3, -0.6	-1.0, -0.5	-0.7, -0.3	-0.5, 0.0	-0.3, 0.2	-0.2, 0.3	

NOTE: For intermediate values of roof slopes and h/d ratios, linear interpolation shall be used. Interpolation shall only be carried out on values of the same sign.

TABLE 5.3(C)
ROOFS—EXTERNAL PRESSURE COEFFICIENTS ($C_{p,e}$) FOR RECTANGULAR
ENCLOSED BUILDINGS—DOWNWIND SLOPE (D), AND (R) FOR HIP
ROOFS, FOR $\alpha \geq 10^\circ$

Roof type and slope		Ratio h/d (see Note)	External pressure coefficients ($C_{p,e}$)			
Crosswind slope for hip roofs (R)	Downwind slope (D)		Roof pitch (α), degrees (see Note)			
			10	15	20	≥ 25
$\alpha \geq 10^\circ$	$\alpha \geq 10^\circ$	≤ 0.25	-0.3	-0.5	-0.6	For $b/d < 3$; -0.6
		0.5	-0.5	-0.5	-0.6	For $3 \leq b/d < 8$; $-0.06(7 + b/d)$
		≥ 1.0	-0.7	-0.6	-0.6	For $b/d > 8$; -0.9

NOTE: For intermediate values of roof slopes and h/d ratios, linear interpolation shall be used. Interpolation shall only be carried out on values of the same sign.

5.4.2 Area reduction factor (K_a) for roofs and side walls

For roofs and sidewalls, the area reduction factor (K_a) shall be as given in Table 5.4. For all other cases, K_a shall be taken as 1.0. Tributary area (A) is the area contributing to the force being considered.

TABLE 5.4
AREA REDUCTION FACTOR (K_a)

Tributary area (A), m^2 (see Note)	Area reduction factor (K_a)
≤ 10	1.0
25	0.9
≥ 100	0.8

NOTE: For intermediate values of A , linear interpolation shall be used.

5.4.3 Action combination factor (K_c)

Where wind pressures acting on a combination of surfaces of an enclosed building (e.g., windward wall, roof, side wall, leeward wall, internal surface) contribute simultaneously to a structural action effect (e.g., member axial force or bending moment) on a structural element, combination factors ($K_{c,e}$ and $K_{c,i}$), less than 1.0, may be applied to the critical external and internal surfaces when calculating the combined forces.

Licensed to Mr timothy Messer on 3 November 2009. Personal use licence only. Storage, distribution or use on network prohibited.

A surface shall be either a windward wall, a side wall, a leeward wall, a roof (upwind and downwind roof shall be treated together as a single surface), or the internal surfaces of the building treated as a single surface. An internal surface shall not be treated as an effective surface if $C_{p,1} < 0.2$.

Where pressures on two contributing surfaces act together in combination to produce a structural action effect, $K_{c,e}$ and $K_{c,i}$ may be taken as 0.9. Where three (or more) contributing surfaces act in combination, $K_{c,e}$ and $K_{c,i}$ may be taken as 0.8.

Examples of appropriate combination factors ($K_{c,e}$ and $K_{c,i}$) are given in Table 5.5.

$K_{c,e}$ and $K_{c,i}$ shall be taken as 1.0 for cladding or minor structural elements (as defined in Appendix A) supporting structure such as purlins, girts and studs.

For any roofs and side walls, the product $K_a \cdot K_{c,e}$ shall not be less than 0.8.

NOTE: Action combination factors less than 1.0 account for the non-simultaneous action of peak pressures on effective surfaces.

TABLE 5.5
EXAMPLES OF ACTION COMBINATION FACTORS $K_{c,e}$ AND $K_{c,i}$ FOR ACTION EFFECTS ON STRUCTURAL ELEMENTS FROM WIND PRESSURE ON EFFECTIVE SURFACES

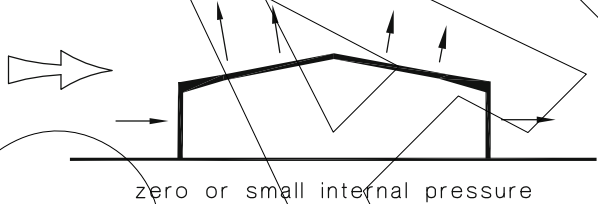
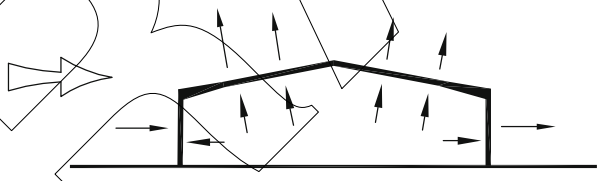
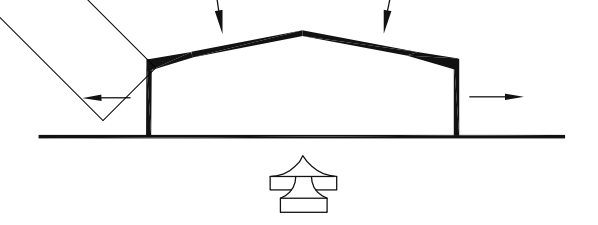
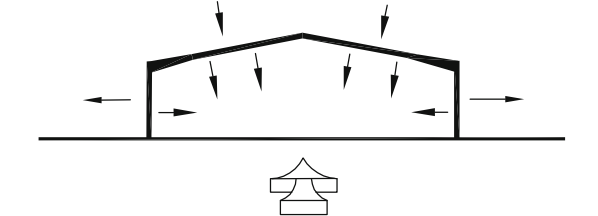
Design case	Example diagram	External $K_{c,e}$	Internal $K_{c,i}$
(a) <i>3 effective surfaces</i> Pressures from windward and leeward walls in combination with roof pressures	 <p style="text-align: center;">zero or small internal pressure</p>	0.8	1.0 (not an effective surface)
(b) <i>4 effective surfaces</i> Pressures from windward and leeward walls in combination with roof pressures and internal pressures		0.8	0.8
(c) <i>3 effective surfaces</i> Pressures from side walls in combination with roof pressures	 <p style="text-align: center;">zero or small internal pressure</p>	0.8	1.0 (not an effective surface)
(d) <i>4 effective surfaces</i> Pressures from side walls in combination with roof pressures and internal pressures		0.8	0.8

Licensed to Mr timothy Messer on 3 November 2009. Personal use licence only. Storage, distribution or use on network prohibited.

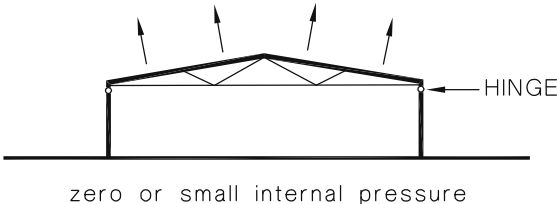
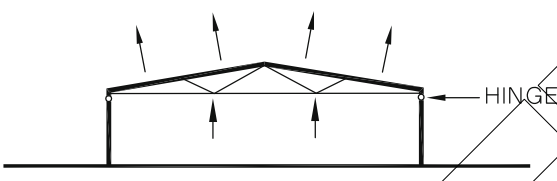
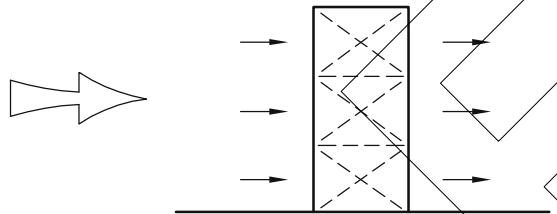
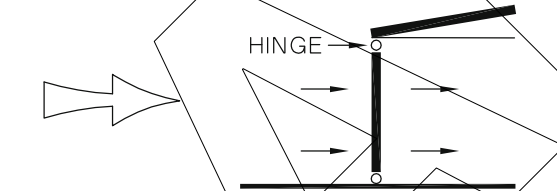
Design case	Example diagram	External $K_{c,e}$	Internal $K_{c,i}$
(e) 1 effective surface Roof pressures acting alone		1.0	1.0 (not an effective surface)
(f) 2 effective surfaces Roof pressures in combination with internal pressures		0.9	0.9
(g) 2 effective surfaces Lateral pressure on windward and leeward walls		0.9	1.0 (not an effective surface)
(h) 2 effective surfaces Lateral pressure on external and internal surfaces		0.9	0.9

5.4.4 Local pressure factor (K_l) for cladding

The local pressure factor (K_l) shall be taken as 1.0 in all cases except when determining the wind forces applied to cladding, their fixings, the members that directly support the cladding, and the immediate fixings of these members. In these cases K_l shall be taken either as 1.0 or from Table 5.6 for the area and locations indicated, whichever gives the most adverse effect when combined with the external and internal pressures. Where more than one case applies, the largest value of K_l from Table 5.6 shall be used.

Where the cladding or the supporting member extends beyond the zone a given in Table 5.6, a value of $K_l = 1.0$ shall apply to wind force contributions imposed from beyond that zone.

The value of dimension a is the minimum of $0.2b$ or $0.2d$ or the height (h) as shown in Figure 5.3.

Where interaction is possible, external pressures shall be taken to act simultaneously with internal pressures given in Clause 5.3 and with the under eaves pressures given in Clause 5.4.1 and the resultant forces shall be added. Design cases for negative pressures in Table 5.6 are alternative cases and shall not be applied simultaneously.

For rectangular buildings, the negative limit on the product $K_l C_{p,e}$ shall be -2.0 in all cases. The RC1 case only applies to flat or near-flat roofs, (slope less than 10 degrees).

For flat or near flat roofs (slope than 10°) with parapets, values of K_l for areas RA1 and RA2 in the lee of the parapet may be modified by multiplying the values from Table 5.6 by the parapet reduction factor (K_r), given in Table 5.7.

TABLE 5.6
LOCAL PRESSURE FACTOR (K_l)

Design case	Figure 5.3 reference number	Aspect ratio (r)	Area (A) m ²	Proximity to edge	K_l
Positive pressures					
Windward wall	WA1	All	$A \leq 0.25a^2$	Anywhere	1.5
All other areas	—	All	—	—	1.0
Negative pressures					
Corners of roofs with pitch $<10^\circ$	RC1	All	$A \leq 0.25a^2$	$<a$ from two edges	3.0
Roof edges	RA1	All	$A \leq a^2$	$<a$	1.5
	RA2	All	$A \leq 0.25a^2$	$<0.5a$	2.0
Hips and ridges of roofs with pitch $\geq 10^\circ$	RA3	All	$A \leq a^2$	$<a$	1.5
	RA4	All	$A \leq 0.25a^2$	$<0.5a$	2.0
Side walls near windward wall edges	SA1	≤ 1	$A \leq a^2$	$<a$	1.5
	SA2		$A \leq 0.25a^2$	$<0.5a$	2.0
	SA3	>1	$A \leq 0.25a^2$	$>a$	1.5
	SA4		$A \leq a^2$	$<a$	2.0
	SA5		$A \leq 0.25a^2$	$\leq 0.5a$	3.0
All other areas	—	All	—	—	1.0

NOTES:

- 1 The dimension a and the Figure reference numbers are defined in Figure 5.3.
- 2 If an area of cladding is covered by more than one case in Table 5.6, use the largest value of K_l obtained for any case.
- 3 The aspect ratio (r) is defined as the average roof height (h) divided by the smaller of b or d .

TABLE 5.7
REDUCTION FACTOR (K_r) DUE TO PARAPETS

h	h_p (see Note)	K_r
≤ 25 m	$\leq 0.07 h$	1.0
	$0.1 h$	0.8
	$\geq 0.2 h$	0.5
> 25 m	$\leq 0.02 w$	1.0
	$0.03 w$	0.8
	$\geq 0.05 w$	0.5

LEGEND:

h_p = height of parapet above average roof level.
 w = shortest horizontal dimension of the building.

NOTE: For intermediate values, linear interpolation shall be used.

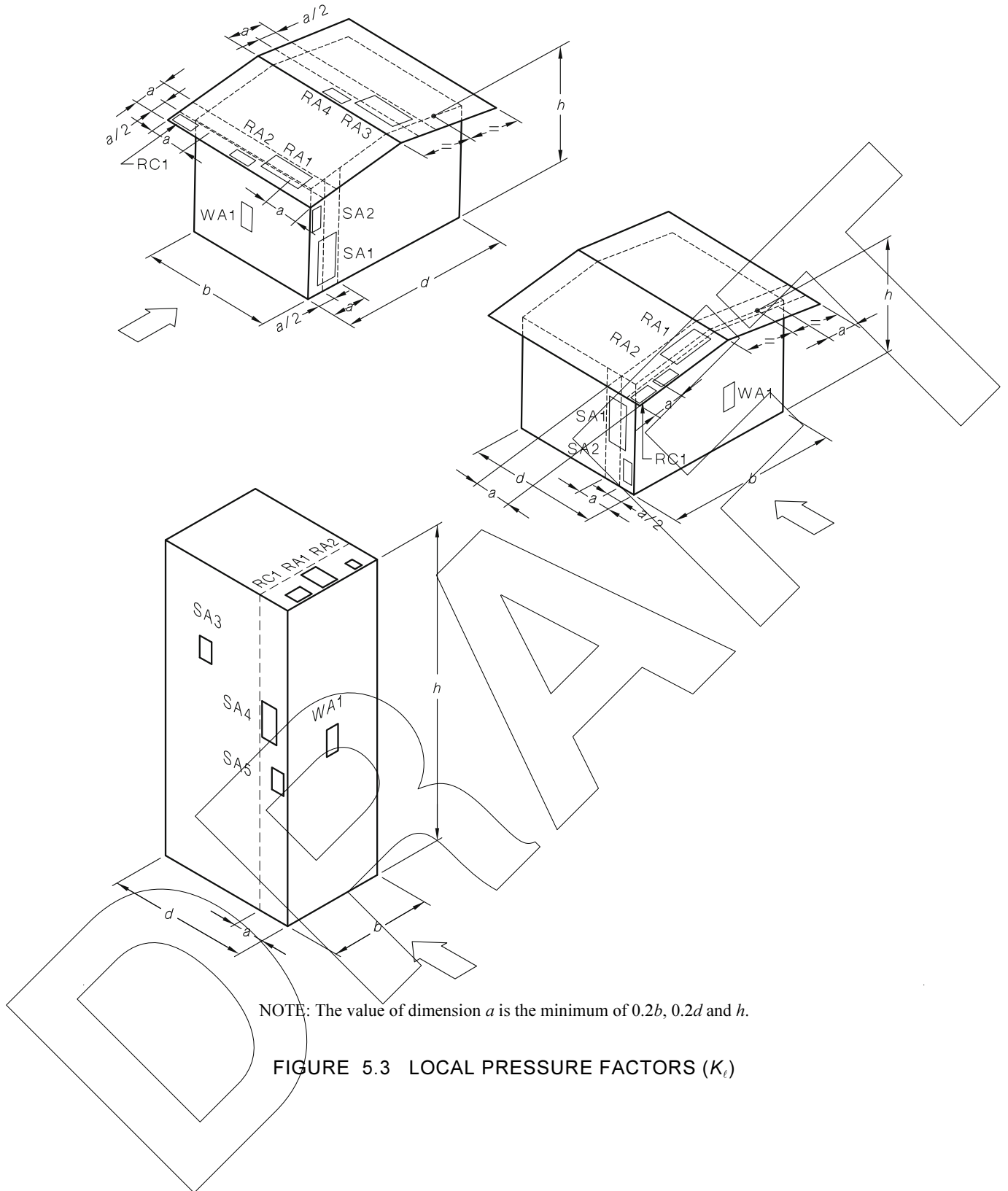

NOTE: The value of dimension a is the minimum of $0.2b$, $0.2d$ and h .

FIGURE 5.3 LOCAL PRESSURE FACTORS (K_t)

5.4.5 Permeable cladding reduction factor (K_p) for roofs and side walls

The permeable cladding reduction factor (K_p) shall be taken as 1.0 except that where an external surface consists of permeable cladding and the solidity ratio is less than 0.999 and exceeds 0.99, the values given in Table 5.8 may be used for negative pressure. The solidity ratio of the surface is the ratio of solid area to total area of the surface. Figure 5.4 shows dimension d_a .

**TABLE 5.8
PERMEABLE CLADDING REDUCTION FACTOR (K_p)**

Horizontal distance from windward edge (see Note)	K_p
0 to $0.2d_a$	0.9
$0.2d_a$ to $0.4d_a$	0.8
$0.4d_a$ to $0.8d_a$	0.7
$0.8d_a$ to $1.0d_a$	0.8

NOTE: d_a is the along-wind depth of the surface, in metres.

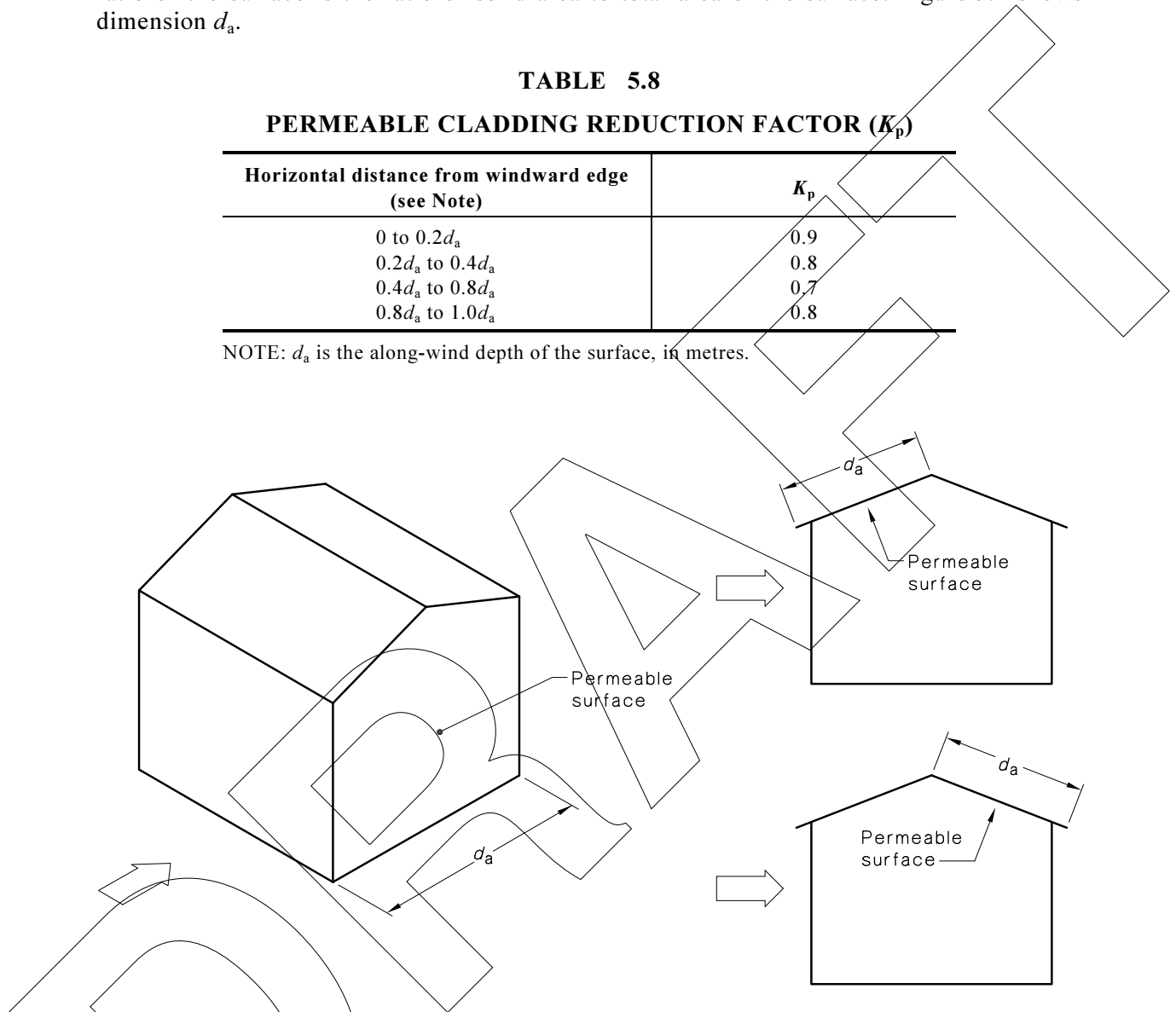

FIGURE 5.4 NOTATION FOR PERMEABLE SURFACES

5.5 FRICTIONAL DRAG FORCES FOR ENCLOSED BUILDINGS

The frictional drag (f) shall be calculated for roofs and side walls of enclosed buildings, in addition to pressures normal to the surface, only where the ratio d/h or d/b is greater than 4. The aerodynamic shape factor (C_{fig}) equals the frictional drag coefficient (C_f) in the direction of the wind as given in Table 5.9.

The effect shall be calculated on the basis of areas as follows:

- (a) For $h \leq b$, area = $(b+2h)(d-4h)$.
- (b) For $h > b$, area = $(b+2h)(d-4b)$.

TABLE 5.9
FRICIONAL DRAG COEFFICIENT (C_f) FOR $d/h > 4$ or $d/b > 4$

Distance ' x ' from windward edge	Surface description	C_f
$x \geq$ the lesser of $4h$ and $4b$	Surfaces with ribs across the wind direction	0.04
	Surfaces with corrugations across the wind direction	0.02
	Smooth surfaces without corrugations or ribs or with corrugations or ribs parallel to the wind direction	0.01
$x <$ the lesser of $4h$ and $4b$	All surfaces	0

SECTION 6 DYNAMIC RESPONSE FACTOR

6.1 EVALUATION OF DYNAMIC RESPONSE FACTOR

The dynamic response factor (C_{dyn}) shall be determined for structures or elements of structures with natural first mode fundamental frequencies as follows:

- (a) Greater than 1 Hz, $C_{dyn} = 1.0$.
- (b) Less than 1 Hz—
 - (i) for tall buildings and towers—
 - (A) less than 0.2 Hz is not covered by this Standard;
 - (B) between 1 Hz and 0.2 Hz, C_{dyn} shall be as defined in Clause 6.2 for along-wind response and Clause 6.3 for crosswind response;
 - (C) where the frequencies of vibration for the two fundamental modes of sway are within 10% of each other and are both less than 0.4 Hz, this is not covered by this Standard;
 - (ii) for cantilever roofs—
 - (A) less than 0.5 Hz is not covered by this Standard;
 - (B) between 1 Hz and 0.5 Hz, C_{dyn} shall be as defined in Paragraph D5, Appendix D.

NOTES:

- 1 Appendix G provides information on calculating accelerations for serviceability in tall wind-sensitive structures.
- 2 For natural frequencies less than 0.2 Hz, heights greater than 200 m, or whenever significant coupling is evident in the first three modes of vibration, wind tunnel testing should be undertaken.

6.2 ALONG-WIND RESPONSE OF TALL BUILDINGS AND TOWERS

6.2.1 General

The dynamic response factor shall be as given in Clause 6.2.2.

NOTE: Information on peak along-wind acceleration for serviceability is given in Appendix G.

6.2.2 Dynamic response factor (C_{dyn})

For calculation of action effects (bending moments, shear forces, member forces) at a height s on the structure (see Figure 6.1), the wind pressures on the structure at a height z shall be multiplied by a dynamic response factor (C_{dyn}). This factor is dependent on both z and s and $s < z < h$. For the calculation of base bending moments, deflections and acceleration at the top of the structure, a single value of C_{dyn} shall be used with s taken as zero. For the calculation of C_{dyn} , the value of $V_{des,\theta}$ is calculated at the reference height (h).

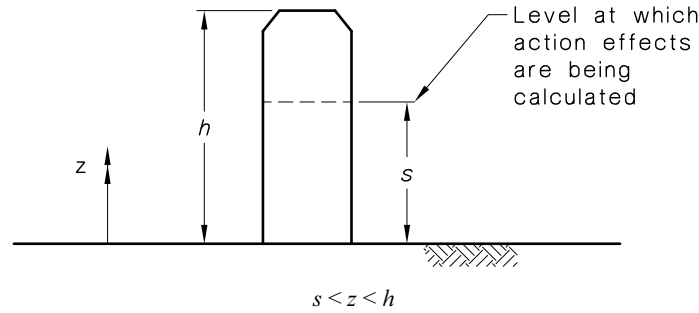

FIGURE 6.1 NOTATION FOR HEIGHTS

The dynamic response factor (C_{dyn}) shall be calculated as follows:

$$C_{dyn} = \frac{1 + 2I_h \sqrt{g_v^2 B_s + \frac{H_S g_R^2 S E_t}{\xi}}}{(1 + 2g_v I_h)} \quad \dots 6.2(1)$$

where

s = height of the level at which action effects are calculated for a structure

h = average roof height of a structure above the ground, or height to the top of a tower

I_h = turbulence intensity, obtained from Table 6.1 by setting $z = h$

g_v = peak factor for the upwind velocity fluctuations, which shall be taken as 3.7

B_s = background factor, which is a measure of the slowly varying background component of the fluctuating response, caused by low frequency wind speed variations, given as follows:

$$B_s = \frac{1}{1 + \frac{\sqrt{0.26(h-s)^2 + 0.46b_{sh}^2}}{L_h}} \quad \dots 6.2(2)$$

where b_{sh} is the average breadth of the structure between heights s and h

$$L_h = \begin{aligned} & \text{a measure of the integral turbulence length scale at height } h \text{ in metres} \\ & = 85(h/10)^{0.25} \end{aligned} \quad \dots 6.2(3)$$

H_s = height factor for the resonant response which equals $1 + (s/h)^2$

$$g_R = \begin{aligned} & \text{peak factor for resonant response (10 min period) given by:} \\ & = \sqrt{2 \log_e(600n_a)} \end{aligned} \quad \dots 6.2(4)$$

S = size reduction factor given as follows, where n_a is first mode natural frequency of vibration of a structure in the along-wind direction in Hertz and b_{0h} is the average breadth of the structure between heights 0 and h :

$$S = \frac{1}{\left[1 + \frac{3.5n_a h (1 + g_v I_h)}{V_{des,0e}} \right] \left[1 + \frac{4n_a b_{0h} (1 + g_v I_h)}{V_{des,0}} \right]} \quad \dots 6.2(5)$$

E_t = ($\pi/4$) times the spectrum of turbulence in the approaching wind stream, given as follows:

$$= \frac{\pi N}{(1 + 70.8N^2)^{5/6}} \dots 6.2(6)$$

where

N = reduced frequency (non dimensional)

= $n_a L_h [1 + (g_v I_h)] / V_{des,0}$

n_a = first mode natural frequency of vibration of a structure in the along-wind direction in hertz

$V_{des,0}$ = building design wind speed determined at the building height, h (see Clause 2.3)

ζ = ratio of structural damping to critical damping of a structure

NOTE: Users should seek other sources including the AS/NZS 1170.2 Supp 1, for advice on possible values of damping as a function of height of building and amplitude of vibration.

**TABLE 6.1
TURBULENCE INTENSITY (I_z)**

Height (z) m	Limit state, region and terrain category			
	Serviceability limit states			
	Terrain category 1, all regions	Terrain category 2, all regions	Terrain category 3, all regions	Terrain category 4, all regions
	Ultimate limit states			
	Terrain category 1, Regions A, W and B	Terrain category 2, Regions A, W and B	Terrain category 3, Regions A, W and B Terrain categories 1, 2, and 3: Regions C and D	Terrain category 4, all regions
≤3	0.171	0.207	0.271	0.342
5	0.165	0.196	0.271	0.342
10	0.157	0.183	0.239	0.342
15	0.152	0.176	0.225	0.342
20	0.147	0.171	0.215	0.342
30	0.140	0.162	0.203	0.305
40	0.133	0.156	0.195	0.285
50	0.128	0.151	0.188	0.270
75	0.118	0.140	0.176	0.248
100	0.108	0.131	0.166	0.233
150	0.095	0.117	0.150	0.210
200	0.085	0.107	0.139	0.196

NOTE: For intermediate values of height (z) and terrain category, linear interpolation shall be used.

6.3 CROSSWIND RESPONSE

6.3.1 General

Clause 6.3.2 gives methods for determining equivalent static forces and base overturning moments and $C_{fig} C_{dyn}$ for tall enclosed buildings and towers of rectangular cross-section, and Clause 6.3.3 gives deflections and equivalent static forces for chimneys, masts and poles of circular cross-section. Calculation of crosswind response is not required for porous lattice towers.

NOTES:

- 1 Where calculations of crosswind response yield high values, further guidance is given in AS/NZS 1170.2 Supp 1.
- 2 Information on peak crosswind acceleration for serviceability is given in Appendix G.
- 3 UHF antennas of the cross-sections shown in Figure E3, Appendix E, may have significant potential for crosswind response.

6.3.2 Crosswind response of tall enclosed buildings and towers of rectangular cross-section

6.3.2.1 Equivalent static crosswind force

The equivalent static crosswind force per unit height (w_{eq}) as a function of z , (evaluated using force equals mass times acceleration) in newtons per metre shall be as follows:

$$w_{eq}(z) = 0.5 \rho_{air} [V_{des,\theta}]^2 d C_{fig} C_{dyn} \quad \dots 6.3(1)$$

where $V_{des,\theta}$ is evaluated at $z = h$, and d is the horizontal depth of the structure parallel to the wind stream and

$$(C_{fig} C_{dyn}) = 1.5 g_R \left(\frac{b}{d}\right) \frac{K_m}{(1 + g_v I_h)^2} \left(\frac{z}{h}\right)^k \sqrt{\frac{\pi C_{fs}}{\zeta}} \quad \dots 6.3(2)$$

where

$$K_m = \begin{cases} \text{mode shape correction factor for crosswind acceleration, given by:} \\ = 0.76 + 0.24k \end{cases}$$

where

k = mode shape power exponent for the fundamental mode. Values of the exponent k should be taken as:

= 1.5 for a uniform cantilever

= 0.5 for a slender framed structure (moment resisting)

= 1.0 for a building with central core and moment-resisting facade

= 2.3 for a tower decreasing in stiffness with height, or with a large mass at the top

= value obtained from fitting $\phi_1(z) = (z/h)^k$ to the computed modal shape of the structure

$\phi_1(z)$ = first mode shape as a function of height z , normalized to unity at $z = h$

C_{fs} = crosswind force spectrum coefficient generalized for a linear mode shape given in Clause 6.3.2.3

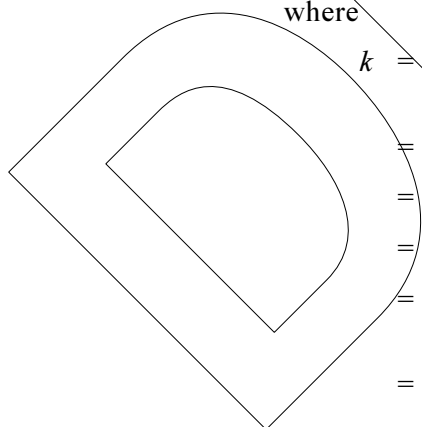

6.3.2.2 Crosswind base overturning moment

The crosswind base overturning moment (M_c), (which can be derived by the integration from 0 to h of $w_{eq}(z) z dz$) shall be as follows:

$$M_c = 0.5g_R b \left[\frac{0.5\rho_{\text{air}} [V_{\text{des},\theta}]^2}{(1 + g_v I_h)^2} \right] h^2 \left(\frac{3}{k+2} \right) K_m \sqrt{\frac{\pi C_{fs}}{\zeta}} \quad \dots 6.3(3)$$

where the value $\left(\frac{3}{k+2} \right) K_m$ is the mode shape correction factor for crosswind base overturning moment.

6.3.2.3 Crosswind force spectrum coefficient (C_{fs})

The reduced velocity (V_n) shall be calculated as follows using $V_{\text{des},\theta}$ calculated at $z = h$, as follows:

$$V_n = \frac{V_{\text{des},\theta}}{n_c b (1 + g_v I_h)} \quad \dots 6.3(4)$$

Values of the crosswind force spectrum coefficient generalized for a linear mode shape (C_{fs}) shall be calculated from the reduced velocity (V_n) as follows (see Figures 6.2 to 6.5):

(a) For a 3:1:1 square section ($h:b:d$), where V_n is in the range 2 to 16:

(i) For turbulence intensity of 0.12 at $2h/3$:

$$\log_{10} C_{fs} = 0.000353V_n^4 - 0.0134V_n^3 + 0.15V_n^2 - 0.345V_n - 3.109 \quad \dots 6.3(5)$$

(ii) For turbulence intensity of 0.2 at $2h/3$:

$$\log_{10} C_{fs} = 0.00008V_n^4 - 0.0028V_n^3 + 0.0199V_n^2 + 0.13V_n - 2.985 \quad \dots 6.3(6)$$

(b) For a 6:1:1 square section ($h:b:d$), where V_n is in the range 3 to 16:

(i) For turbulence intensity of 0.12 at $2h/3$:

$$\log_{10} C_{fs} = 0.000406V_n^4 - 0.0165V_n^3 + 0.201V_n^2 - 0.603V_n - 2.76 \quad \dots 6.3(7)$$

(ii) For turbulence intensity of 0.2 at $2h/3$:

$$\log_{10} C_{fs} = 0.000334V_n^4 - 0.0125V_n^3 + 0.141V_n^2 - 0.384V_n - 2.36 \quad \dots 6.3(8)$$

(c) For a 6:2:1 rectangular section ($h:b:d$), where V_n is in the range 2 to 18:

(i) For turbulence intensity of 0.12 at $2h/3$:

$$\log_{10} C_{fs} = \frac{-3.2 + 0.0683V_n^2 - 0.000394V_n^4}{1 - 0.02V_n^2 + 0.000123V_n^4} \quad \dots 6.3(9)$$

(ii) For turbulence intensity of 0.2 at $2h/3$:

$$\log_{10} C_{fs} = \frac{-3 + 0.0637V_n^2 - 0.00037V_n^4}{1 - 0.02V_n^2 + 0.000124V_n^4} \quad \dots 6.3(10)$$

(d) For a 6:1:2 rectangular section ($h:b:d$), where V_n is in the range 2 to 16:

(i) For turbulence intensity of 0.12 at $2h/3$:

$$\log_{10} C_{fs} = 0.000457V_n^3 - 0.0226V_n^2 + 0.396V_n - 4.093 \quad \dots 6.3(11)$$

(ii) For turbulence intensity of 0.2 at $2h/3$:

$$\log_{10} C_{fs} = 0.00038V_n^3 - 0.0197V_n^2 + 0.363V_n - 3.82 \quad \dots 6.3(12)$$

NOTE: For intermediate values of $h:b$, $b:d$, or turbulence intensity, linear interpolation of $\log_{10} C_{fs}$ shall be used.

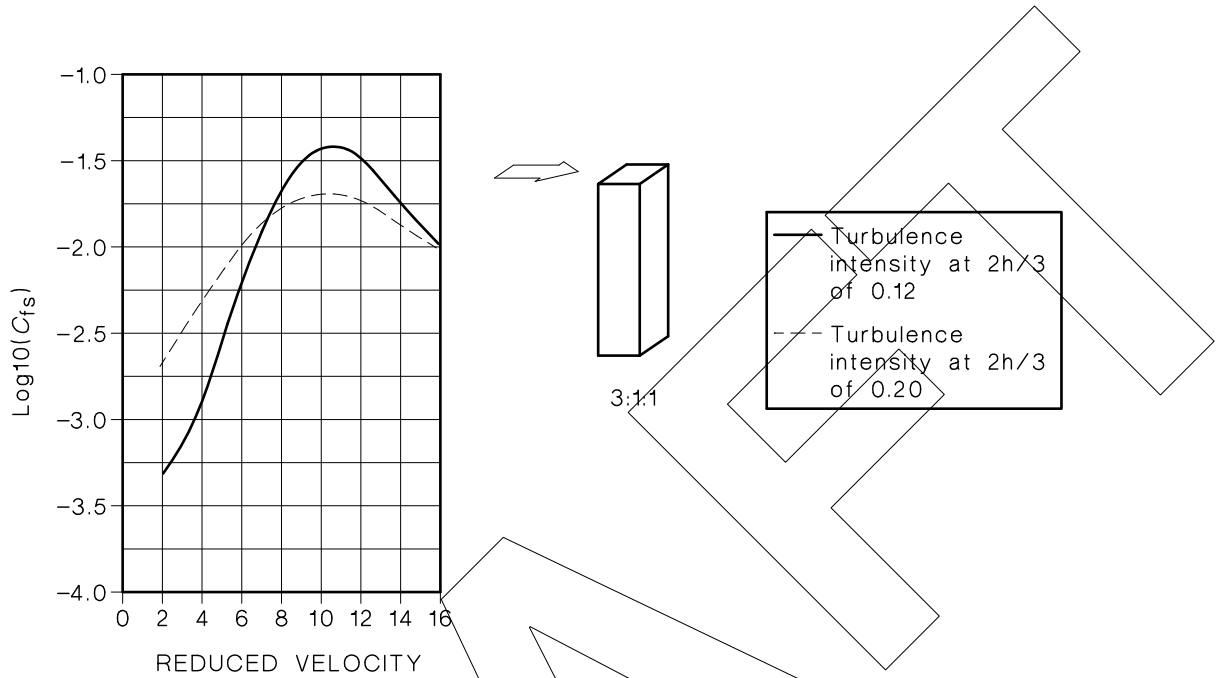

FIGURE 6.2 CROSSWIND FORCE SPECTRUM COEFFICIENT FOR A 3:1:1 SQUARE SECTION

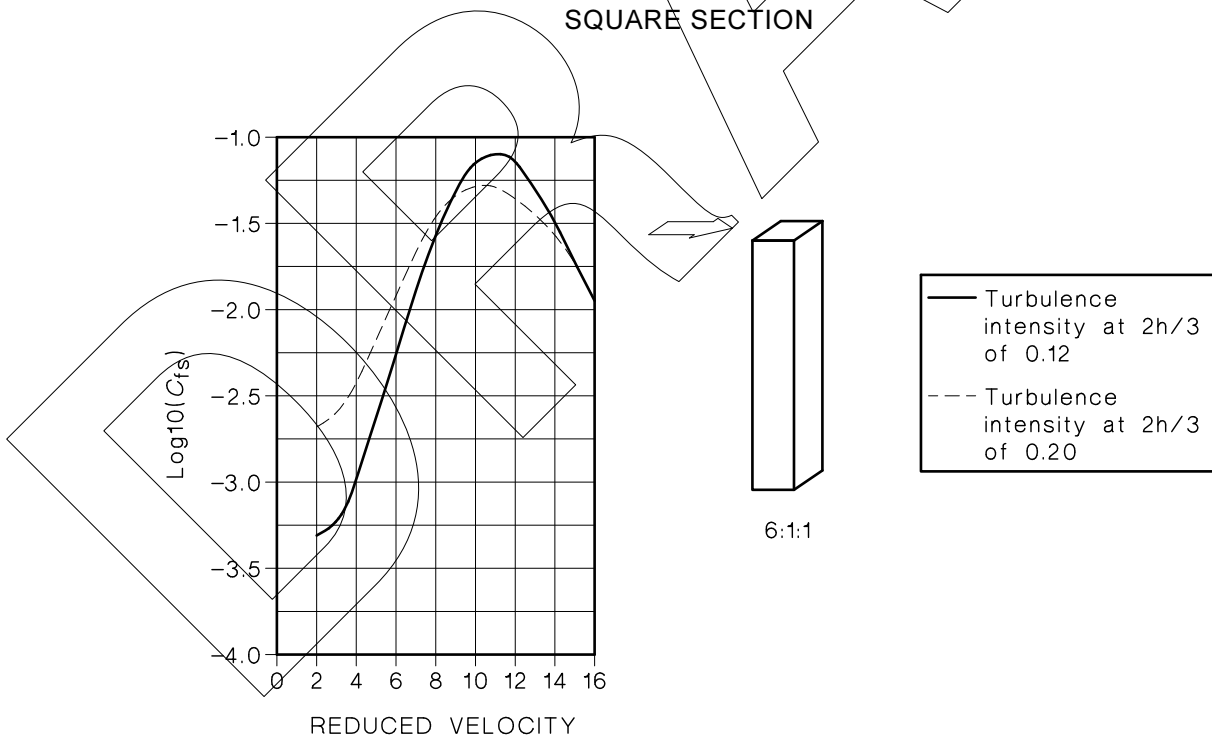

FIGURE 6.3 CROSSWIND FORCE SPECTRUM COEFFICIENT FOR A 6:1:1 SQUARE SECTION

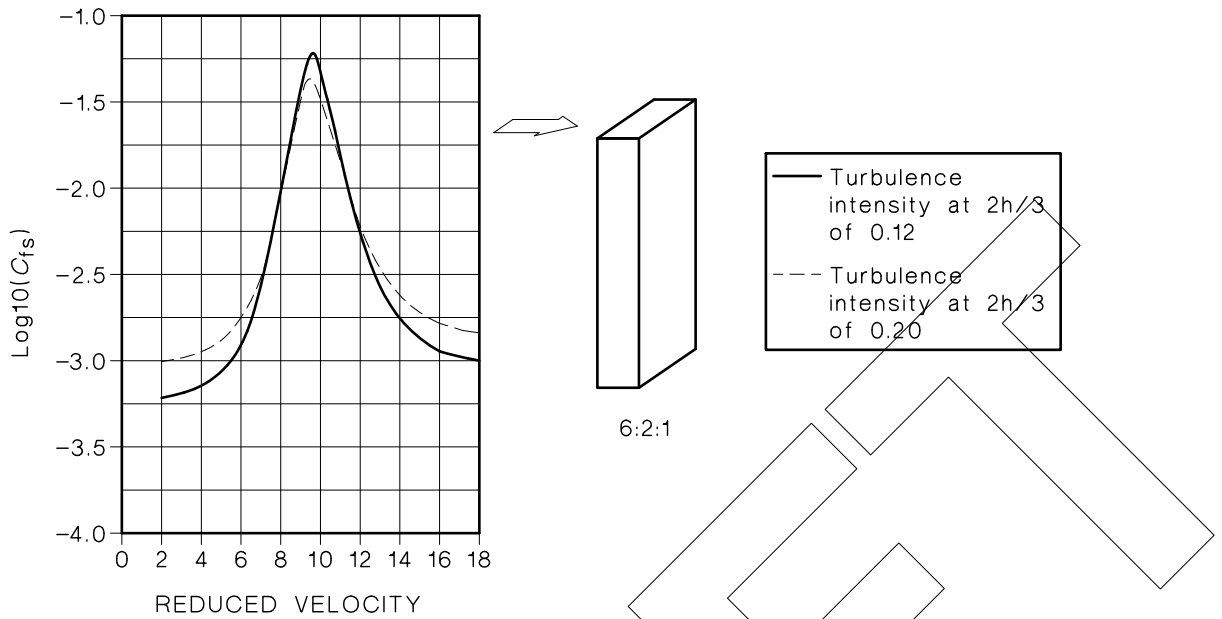

FIGURE 6.4 CROSSWIND FORCE SPECTRUM COEFFICIENT FOR A 6:2:1 RECTANGULAR SECTION

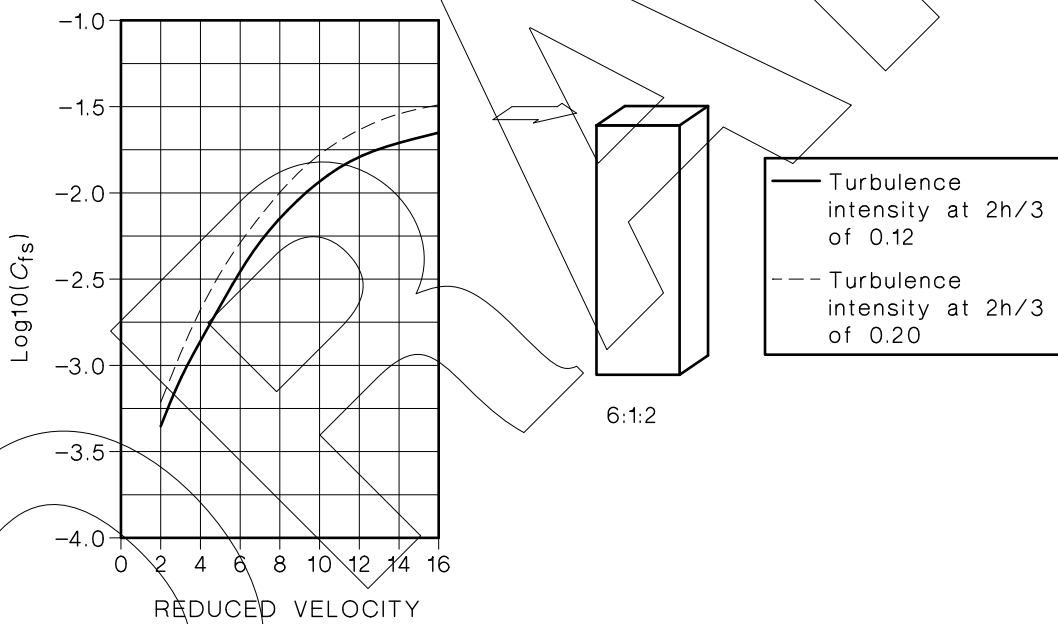

FIGURE 6.5 CROSSWIND FORCE SPECTRUM COEFFICIENT FOR A 6:1:2 RECTANGULAR SECTION

6.3.3 Crosswind response of chimneys, masts and poles of circular cross-section

6.3.3.1 Crosswind tip deflection

The maximum amplitude of tip deflection (y_{max}) in crosswind vibration at the critical wind speed due to vortex shedding for chimneys, masts or poles of circular cross-section (without ladders, strakes or other appendages near the top) shall be calculated as follows:

$$y_{max} = Kb_v/Sc \quad \dots 6.3(13)$$

where

K = factor for maximum tip deflection, taken as 0.50 for circular cross-sections

- b_t = average breadth of the top third of the structure
- Sc = Scruton number given by:
 - = $4\pi m_t \zeta / (\rho_{\text{air}} b^2)$
 - m_t = average mass per unit height over the top third of the structure
 - ζ = ratio of structural damping to critical damping of a structure,

6.3.3.2 Equivalent static crosswind force

The equivalent static wind force per unit height (w_{eq}) for chimneys, masts or poles of circular cross-section (without ladders, strakes or other appendages near the top), as a function of height z , $w_{\text{eq}}(z)$, shall be calculated as follows:

$$w_{\text{eq}}(z) = m(z) (2\pi n_1)^2 y_{\text{max}} \phi_1(z) \quad \dots 6.3(14)$$

where

- $m(z)$ = mass per unit height as a function of height (z)
- n_1 = first mode natural frequency of vibration of a structure, in hertz
- $\phi_1(z)$ = first mode shape as a function of height (z), normalized to unity at $z = h$, which shall be taken as $(z/h)^2$

NOTE: Equation 6.3(14) may be written as:

$$w_{\text{eq}}(z) = 0.5 \rho_{\text{air}} [V_{\text{crit}}]^2 \cdot b_t \cdot C_{\text{fig}} \cdot C_{\text{dyn}}$$

where

- V_{crit} = critical wind speed for vortex shedding, which is approximately $5n_1 \times b_t$ for circular sections.
- $C_{\text{fig}} \times C_{\text{dyn}}$ = the product of effective aerodynamic shape factor and dynamic response factor

6.4 COMBINATION OF ALONG-WIND AND CROSSWIND RESPONSE

The total combined peak scalar dynamic action effect (ϵ_t), such as an axial load in a column, shall be as follows:

$$\epsilon_t = \epsilon_{a,m} + \left[(\epsilon_{a,p} - \epsilon_{a,m})^2 + \epsilon_{c,p}^2 \right]^{0.5} \quad \dots 6.4(1)$$

where

- $\epsilon_{a,m}$ = action effect derived from the mean along-wind response, given as follows, where the values of g_v , I_h and C_{dyn} are defined in Clause 6.2.2:
 - = $\epsilon_{a,p} / [C_{\text{dyn}} (1 + 2g_v I_h)]$
- $\epsilon_{a,p}$ = action effect derived from the peak along-wind response
- $\epsilon_{c,p}$ = action effect derived from the peak crosswind response

NOTE:

- 1 The factor $[C_{\text{dyn}} (1 + 2g_v I_h)]$ is a gust factor (G).
- 2 Maximum action effects derived from the crosswind response of chimneys, masts and poles of circular cross section (Clause 6.3.3), which occur at the critical wind speed for vortex shedding, should not be combined with action effects for along-wind response calculated at a different wind speed.

APPENDIX A DEFINITIONS

(Normative)

For the purposes of this Standard, the definitions given herein apply.

Aerodynamic shape factor

Factor to account for the effects of the geometry of the structure on surface pressure due to wind.

Annual probability of exceedence of the action

The probability that a value will be exceeded in any one year.

NOTE: This is the inverse of the so-called 'return period' better described as the average recurrence interval.

Aspect ratio

Ratio of the average roof height of a building to the smallest horizontal dimension, or the ratio of the largest dimension of a structural member to its cross-wind breadth.

Awning

Roof-like structure, usually of limited extent, projecting from a wall of a building.

Canopy

Roof adjacent to or attached to a building, generally not enclosed by walls.

Cladding

Material that forms the external surface over the framing of a building or structure.

Design wind speed

Wind speed for use in design, adjusted for annual probability of exceedence, wind direction, geographic position, surrounding environment and height.

NOTE: For structures over 25 m, design wind speed is expressed as a function of height.

Dominant opening

Opening in the external surface of an enclosed building, which directly influences the average internal pressure in response to external pressures at that particular opening.

NOTE: Dominant openings need not be large.

Downdraft

Vertical air motion originating in a thunderstorm, resulting in severe horizontal winds at ground level.

Drag

Force acting in the direction of the wind stream; *see also* lift.

Dynamic response factor

Factor to account for the effects of fluctuating forces and resonant response on wind-sensitive structures.

Eccentricity

The distance of the centroid of a surface, to the point of application of the resultant force derived from the net wind pressure.

Effective surface

A wall, roof or internal surface of a building that contributes significantly to load effects on major structural elements.

Elevated building

Building with a clear, unwallled space underneath the first floor level with a height from ground to underside of the first floor of one-third or more of the total height of the building.

Enclosed building

Building that has a roof and full perimeter walls (nominally sealed) from floor to roof level.

Escarpment

Long, steeply sloping, face between nominally level lower and upper plains where the plains have average slopes of not greater than 5%.

First mode shape

Shape of a structure at its maximum amplitude under first mode natural vibration.

First mode natural frequency

Frequency of free oscillation corresponding to the lowest harmonic of vibration of a structure.

Force coefficient

Coefficient that, when multiplied by the incident wind pressure and a reference area, gives the force in a specific direction.

Free roof

Roof (of any type) with no enclosing walls underneath (e.g., freestanding carport).

Freestanding walls

Walls that are exposed to the wind on both sides, with no roof attached (e.g., fences).

Frictional drag

Wind force per unit area acting in a direction parallel to the surface in question.

Gable roof

Ridged roof with two sloping surfaces and vertical end walls triangular from lowest points up to the ridge.

Hip roof

A roof with four sloping (pitched) surfaces, pyramidal in shape, and with level eaves all round. A hip roof on a rectangular plan has two triangular sloping roofs at the short sides (hip ends) and two trapezoidal sloping roofs at the long sides.

Hoardings

Freestanding (rectangular) signboards, and the like, supported clear of the ground.

Immediate supports (cladding)

Those supporting members to which cladding is directly fixed (e.g., battens, purlins, girts, studs).

Lag distance

Horizontal distance downwind, required for the effects of a change in terrain roughness on wind speed to reach the height being investigated.

Lattice towers

Three-dimensional frameworks comprising three or more linear boundary members interconnected by linear bracing members joined at common points (nodes), enclosing an open area through which the wind may pass.

Lift

Force acting at 90° to the wind stream; *see also* drag.

Mansard roof

A roof with two slopes on all four sides, the lower slope steeper than the upper slope.

NOTE: A mansard roof with the upper slopes less than 10° may be assumed to be flat topped.

Monoslope roof

Planar roof with a constant slope and without a ridge.

Obstructions

Natural or man-made objects that generate turbulent wind flow, ranging from single trees to forests and from isolated small structures to closely spaced multistorey buildings.

Permeable

Surface with an aggregation of small openings, cracks, and the like, which allows air to pass through under the action of a pressure differential.

Pitched roof

Bi-fold, bi-planar roof (two sloping surfaces) meeting at the highest point ridge.

Pressure

Air pressure referenced to ambient air pressure.

NOTE: In this Standard, negative values are less than ambient (suction), positive values exceed ambient. Net pressures act normal to a surface in the direction specified.

Pressure coefficient

Ratio of the pressure acting at the point on a surface, to the free stream dynamic pressure of the incident wind.

Rectangular building

For the purposes of Section 5 of this Standard, rectangular buildings include buildings generally made up of rectangular shapes in plan.

Reynolds number

The ratio of the inertial forces to the viscous forces in the airflow.

Ridge (topographic feature)

Long crest or chain of hills that have a nearly linear apex, with sloping faces on either side of the crest.

Roughness length

Theoretical quantification of the turbulence-inducing nature of a particular type of terrain on airflow (wind).

Scruton number

A mass-damping parameter.

Solidity (of cladding)

Ratio of the solid area to the total area of the surface.

Structural elements, major

Structural elements whose tributary areas are greater than 10 m².

Structural elements, minor

Structural elements whose tributary areas are less than or equal to 10 m².

Terrain

Surface roughness condition when considering the size and arrangement of obstructions to the wind.

Topography

Major land surface features, comprising hills, valleys and plains, that strongly influence wind flow patterns.

Tornado

Violently rotating column of air, that is suspended, observable as a funnel cloud attached to the cloud base of a convective cloud.

Tributary area

Area of building surface contributing to the force being considered.

Tropical cyclone

An intense low-pressure centre accompanied by heavy rain and gale-force winds or greater. It forms over warm tropical oceans and decays rapidly over land. Such systems affect a large area and, in the southern hemisphere, winds spiral clockwise into the centre.

Troughed roof

Bi-fold, bi-planar roof with a valley at its lowest point.

Turbulence intensity

The ratio of the standard deviation of the fluctuating component of wind speed to the mean (time averaged) wind speed.

APPENDIX B

NOTATION

(Normative)

Unless stated otherwise, the notation used in this Standard shall have the following meanings with respect to a structure, or member, or condition to which a clause is applied.

NOTE: See Clause 1.5 for units.

- A = surface area of the element or the tributary area which transmits wind forces to the element, being—
- = area upon which the pressure acts, which may not always be normal to the wind stream when used in conjunction with the pressure coefficient (C_p);
 - = projected area normal to the wind stream when used in conjunction with a drag force coefficient (C_d); or
 - = areas as defined in applicable clauses (see Appendix E) when used in conjunction with a force coefficient, ($C_{F,x}$) or ($C_{F,y}$)
- A_a = reference area of ancillaries on a tower
- A_{ref} = reference area of flag
- $A_{z,s}$ = total projected area of the tower section at height z
- A_z = a reference area, at height (z), upon which the pressure (p_z) at that height acts
- a = constant for ease of calculation (Paragraph E4.2.3, Appendix E)
- or*
- dimension used in defining the extent of application of local pressure factors
- B_s = background factor, which is a measure of the slowly varying background component of the fluctuating response, caused by low frequency wind speed variations
- b = breadth of a structure or element, usually normal to the wind stream (see Figures 5.2, C5, C7 of Appendix C, D1 of Appendix D, E1, E2, E4 and Tables E3, E4 and E5 of Appendix E)
- or*
- average diameter of a circular section
- b_D = diagonal breadth of UHF antennas
- b_i = average diameter or breadth of a section of a tower member
- b_N = normal breadth of UHF antennas
- b_{0h} = average breadth of the structure between heights 0 and h
- b_s = average breadth of shielding buildings, normal to the wind stream
- b_{sh} = average breadth of the structure between heights s and h
- b_t = average breadth of the top third of the structure
- b_z = average breadth of the structure at the section at height (z)
- b/w = ratio of the average diameter of an ancillary to the average width of a structure
- C_d = drag force coefficient for a structure or member in the direction of the wind stream

- C_{da} = value of drag force coefficient (C_d) on an isolated ancillary on a tower
 C_{de} = effective drag force coefficient for a tower section with ancillaries
 C_{dyn} = dynamic response factor
 $C_{F,x}$ = force coefficient for a structure or member, in the direction of the x -axis
 $C_{F,y}$ = force coefficient for a structure or member, in the direction of the y -axis
 C_f = frictional drag force coefficient
 C_{fig} = aerodynamic shape factor
 $C_{fig,l}$ = aerodynamic shape factor for the first frame in the upwind direction
 C_{fs} = crosswind force spectrum coefficient generalized for a linear mode shape
 $C_{p,b}$ = external pressure coefficient for sides of bins, silos and tanks
 $C_{p,e}$ = external pressure coefficient
 $C_{p,i}$ = internal pressure coefficient
 $C_{p,l}$ = net pressure coefficient for the leeward half of a free roof
 $C_{p,n}$ = net pressure coefficient acting normal to the surface for canopies, freestanding roofs, walls, and the like
 $C_{p,w}$ = net pressure coefficient for the windward half of a free roof
 $C_{p1}(\theta_b)$ = external pressure coefficient on walls of bins, silos or tanks of unit aspect ratio ($c/b = 1$) as a function of θ_b
 c = constant for ease of calculation (Paragraph E4.2.3)
or
 = net height of a hoarding, flag, bin, silo or tank (not including roof or lid height)
or
 = height between the highest and lowest points on a hyperbolic paraboloid roof
 D = downwind roof slope
 d = depth or distance parallel to the wind stream to which the plan or cross-section of a structure or shape extends (e.g. outside diameter)
or
 = length of span of curved roof
 d_a = along-wind depth of a porous wall or roof surface
 d_s = length of span of the first pitched roof in a multi-span building
 E = site elevation above mean sea level
 E_t = spectrum of turbulence in the approaching wind stream
 e = the base of Napierian logarithms (≈ 2.71828)
 e = horizontal eccentricity of net pressure
 F = force on a building element, in Newtons
 F_C = factor for region C to account for lack of recent analysis of cyclone activity
 F_D = factor for region D to account for lack of recent analysis of cyclone activity
 f = frictional force per unit area parallel to a surface, in Newtons per square metre

- f_z = the design frictional distributed force parallel to the surface, calculated in Clause 2.4.2 at height z , in newtons per square metre
- g_R = peak factor for resonant response (10 min period)
- g_v = peak factor for the upwind velocity fluctuations
- H = height of the hill, ridge or escarpment
- H_s = height factor for the resonant response
- h = average roof height of structure above ground
- h_c = height from ground to the attached canopy, freestanding roof, wall, or the like
- h_p = height of parapet above average roof level
- h_r = average height of surface roughness
- h_s = average roof height of shielding buildings
- I_h = turbulence intensity, obtained from Table 6.1 by setting z equal to h
- I_z = turbulence intensity at height z given for various terrain categories in Table 6.1
- K = factor for maximum tip deflection
- K_a = area reduction factor
- K_{ar} = aspect ratio correction factor for individual member forces
- K_c = combination factor
- $K_{c,e}$ = combination factor for external pressures
- $K_{c,i}$ = combination factor for internal pressures
- K_i = factor to account for the angle of inclination of the axis of members to the wind direction
- K_{in} = correction factor for interference
- K_l = local pressure factor
- K_m = mode shape correction factor for crosswind acceleration
- K_p = net porosity factor, used for free walls
- or
- K_r = porous cladding reductive factor, used for cladding on buildings
- K_r = parapet reduction factor
- K_{sh} = shielding factor for shielded frames in multiple open-framed structures
- k = mode shape power exponent
- k_b = factor for a circular bin
- L_h = measure of integral turbulence length scale at height h
- L_u = horizontal distance upwind from the crest of the hill, ridge or escarpment to a level half the height below the crest
- L_1 = length scale, in metres, to determine the vertical variation of M_h , to be taken as the greater of $0.36 L_u$ or $0.4 H$
- L_2 = length scale, in metres, to determine the horizontal variation of M_h , to be taken as $4 L_1$ upwind for all types, and downwind for hills and ridges, or $10 L_1$ downwind for escarpments

L	= leeward wall
l	= length of member
l_f	= flag length
l_s	= average spacing of shielding buildings
M_c	= crosswind base overturning moment
M_d	= wind direction multiplier (see Clause 3.3)
M_s	= shielding multiplier
M_t	= topographic multiplier
M_h	= hill shape multiplier
M_{lee}	= lee (effect) multiplier (taken as 1.0, except in New Zealand lee zones, see Clause 4.4.3)
$M_{z,cat}$	= terrain/height multiplier
m_0	= average mass per unit height
m_f	= mass per unit area of flag
m_t	= average mass per unit height over the top third of the structure
$m(z)$	= mass per unit height as a function of height z
N	= reduced frequency (non-dimensional)
n	= number of spans of a multi-span roof
n_1	= first mode natural frequency of vibration of a structure, in Hertz
n_a	= first mode natural frequency of vibration of a structure in the along-wind direction, in Hertz
n_c	= first mode natural frequency of vibration of a structure in the crosswind direction, in Hertz
n_s	= number of upwind shielding buildings within a 45° sector of radius $20h$ and with $h_s \geq h$
p	= design wind pressure acting normal to a surface, in pascals = p_e , p_i or p_n where the sign is given by the C_p values used to evaluate C_{fig} NOTE: Pressures are taken as positive, indicating pressures above ambient and negative, indicating pressures below ambient.
p_e	= external wind pressure
p_i	= internal wind pressure
p_n	= net wind pressure
p_z	= design wind pressure, in pascals (normal to the surface), at height z , calculated in Clause 2.4.1 NOTE: The sign convention for pressures leads to forces towards the surface for positive pressures and forces away from the surface for negative pressures.
R	= inverse of the annual probability of exceedence of the wind speed
R	= crosswind roof slope
Re	= Reynolds number
r	= Rise of a curved roof;

Corner radius of a structural shape; or
Aspect ratio of a building (Clause 5.4.4)

S = size reduction factor

S = side wall

Sc = Scruton number

s = shielding parameter; *or*

= height of the level at which action effects are calculated for a structure

T = top roof section

U = upwind roof slope

$V_{des,\theta}$ = building orthogonal design wind speeds (usually, $\theta = 0^\circ, 90^\circ, 180^\circ$, and 270°), as given in Clause 2.3

NOTE: $V_{des,\theta}$ may be expressed as a function of height z , for some applications, e.g. windward walls of tall buildings (>25m).

$V_{des,\theta}(z)$ = building orthogonal design wind speeds as a function of height z

V_n = reduced velocity (non dimensional)

$V_{sit,\beta}$ = wind speeds for a site, varying according to compass direction

V_R = regional 3 second gust wind speed, in metres per second, for annual probability of exceedence of $1/R$

W = wind actions (see AS/NZS 1170.0)

W = windward wall

W_s = Wind actions for serviceability limit states (determined using a regional wind speed appropriate to the annual probability of exceedence for serviceability limit states)

W_u = Wind actions for ultimate limit states (determined using a regional wind speed appropriate to the annual probability of exceedence specified for ultimate limit states)

$w_{eq}(z)$ = equivalent static wind force per unit height as a function of height z

w = width of a tower; *or*

= shortest horizontal dimension of the building

w_c = width of canopy, awning carport, or similar, from the face of the building

x = distance from the windward edge of a canopy or cantilevered roof; *or*

= horizontal distance upwind or downwind of the structure to the crest of the hill, ridge or escarpment

x_i = distance downwind from the start of a new terrain roughness to the position where the developed height of the inner layer equals z (lag distance)

\ddot{x}_{max} = peak acceleration, at the top of a structure in the along-wind direction

\ddot{y}_{max} = peak acceleration, at the top of a structure in the crosswind direction

y_{max} = maximum amplitude of tip deflection in crosswind vibration at the critical wind speed

z = reference height on the structure above the average local ground level

- $z_{0,r}$ = larger of the two roughness lengths at a boundary between roughnesses
 α = angle of slope of a roof
 β = angle of compass wind direction, measured clockwise from North (0°), for determining site wind velocities
 ΔC_d = additional drag coefficient due to an ancillary attached to one face or located inside the tower section
 Δz = height of the section of the structure upon which the wind pressure acts
 δ = solidity ratio of the structure (surface or open frame) which is the ratio of solid area to total area of the structure
 δ_e = effective solidity ratio for an open frame
 $\varepsilon_{a,m}$ = action effect derived from the mean along-wind response
 $\varepsilon_{a,p}$ = action effect derived from the peak along-wind response
 $\varepsilon_{c,p}$ = action effect derived from the peak crosswind response
 ε_t = combined peak scalar dynamic action effect
 ζ = ratio of structural damping to critical damping of a structure
 θ = angle of the upwind direction to the orthogonal axes of a structure, in degrees
 θ_a = angle of deviation of the wind stream from the line joining the centre of the tower cross-section to the centre of the ancillary, in degrees
 θ_b = angle from the wind direction to a point on the wall of a circular bin, silo or tank, in degrees
 θ_m = angle between the wind direction and the longitudinal axis of the member, in degrees
 λ = spacing ratio for parallel open frames, equal to the frame spacing (centre-to-centre) divided by the projected frame width normal to the wind direction
 π = the ratio of the circumference of any circle to its diameter (approx. 3.14159)
 ρ_{air} = density of air, which shall be taken as 1.2 kg/m^3
 NOTE: This value is based on 20°C and typical ground level atmospheric pressure and variation may be necessary for very high altitudes or cold environments.
 $\phi_1(z)$ = first mode shape as a function of height z , normalized to unity at $z = h$

APPENDIX C

ADDITIONAL PRESSURE COEFFICIENTS FOR ENCLOSED BUILDINGS

(Normative)

C1 ADDITIONAL PRESSURE COEFFICIENTS

The external pressure coefficients ($C_{p,e}$) given in this Appendix shall be used to calculate the aerodynamic shape factor for pressures on appropriately shaped enclosed buildings in accordance with Clauses 5.2 and 5.4.

C2 MULTI-SPAN BUILDINGS ($\alpha < 60^\circ$)

External pressure coefficients ($C_{p,e}$) for the multi-span buildings shown in Figures C1 and C2 for wind directions $\theta = 0^\circ$ and $\theta = 180^\circ$ shall be obtained from Table C1 or Table C2.

Where two values are listed for pressure coefficients in Tables C1 and C2, the roof shall be designed for both values.

All pressure coefficients shall be used with the value of wind speed applying at average roof height (h).

External pressure coefficients for wind directions of $\theta = 90^\circ$ and $\theta = 270^\circ$ shall be obtained from Clause 5.4 but $[-0.05(n - 1)]$ shall be added to the roof pressure coefficients in the region 0 to $1h$ from the leading edge, where n is the total number of spans. For this calculation, take $n = 4$, if n is greater than 4.

TABLE C1
EXTERNAL PRESSURE COEFFICIENTS ($C_{p,e}$) FOR
MULTI-SPAN BUILDINGS—PITCHED ROOFS

Surface reference (see Figure C1)				
A	B	C	M	Y
0.7	Use Table 5.3(a), 5.3(b) or 5.3(c) for same (h/d_s) and α , as appropriate		-0.3 and 0.2 for $\alpha < 10^\circ$ -0.5 and 0.3 for $\alpha \geq 10^\circ$	-0.2

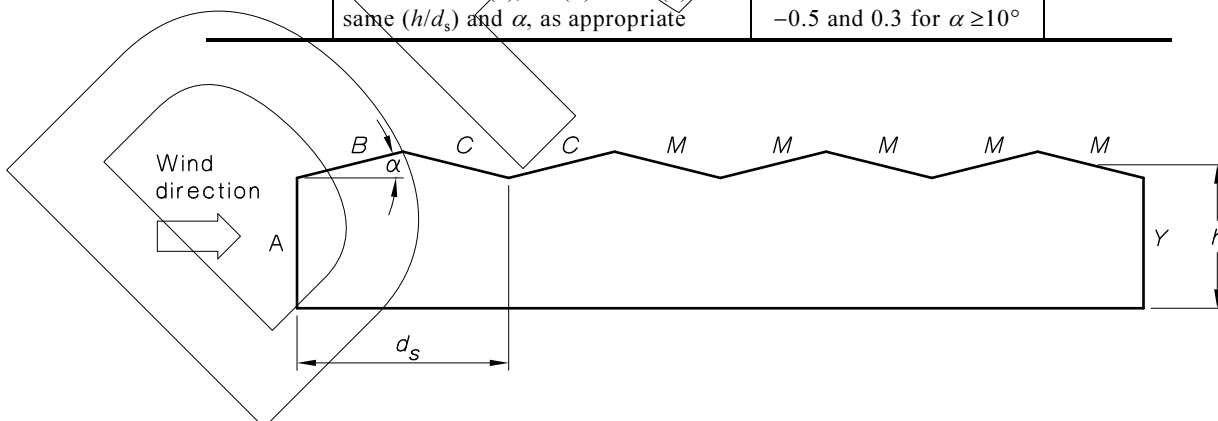

FIGURE C1 EXTERNAL PRESSURE COEFFICIENTS ($C_{p,e}$) FOR MULTI-SPAN BUILDINGS—PITCHED ROOFS

TABLE C2
EXTERNAL PRESSURE COEFFICIENTS ($C_{p,e}$) FOR
MULTI-SPAN BUILDINGS—SAW-TOOTH ROOFS

Wind direction (θ) degrees	Surface reference (see Figure C2)								
	A	B	C	D	M	N	W	X	Y
0	0.7	-0.9	-0.9	-0.5, 0.2	-0.5, 0.5	-0.5, 0.3	-0.3, 0.5	-0.4	-0.2
180	-0.2	-0.2, 0.2	-0.3	-0.2, 0.2	-0.4	-0.4	-0.7	-0.3	0.7

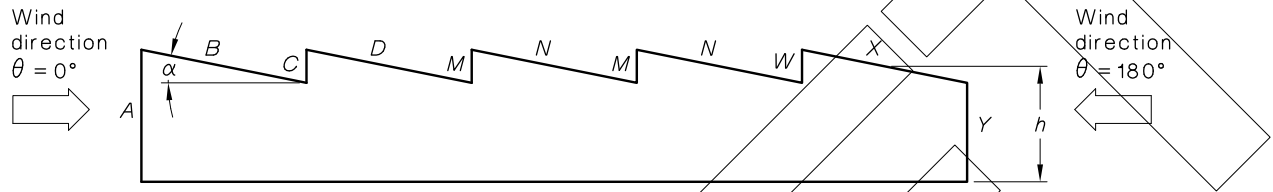

FIGURE C2 EXTERNAL PRESSURE COEFFICIENTS ($C_{p,e}$) FOR MULTI-SPAN BUILDINGS—SAW-TOOTH ROOFS

C3 BUILDINGS WITH CURVED ROOFS

External pressure coefficients ($C_{p,e}$) for curved, arched or domed roofs with profiles approximating a circular arc, for wind directions normal to the axis of the roof, shall be obtained from Table C3.

When two values are listed, the roof shall be designed for both values. In these cases, roof surfaces may be subjected to either positive or negative values due to turbulence. Alternative combinations of external and internal pressures (see Clause 2.5) shall be considered, to obtain the most severe conditions for design.

All pressure coefficients shall be used with the value of wind speed applying at average roof height (h).

External pressure coefficients ($C_{p,e}$) for wind directions parallel to the axis (ridge) of arched roofs shall be obtained from Table 5.3(A).

The zero values provided for the windward quarter are alternative values for action effects, such as bending, which are sensitive to pressure distribution (turbulence and fluctuations in pressure will produce a range of values occurring at different times during a wind event).

For arched roofs, the effect of length to span ratio shall be taken into account by multiplying all the coefficients in Table C3 by a factor of $(b/d)^{0.25}$, where b = breadth normal to the wind and d = span (see Figure C3). If $(b/d)^{0.25}$ is less than 1.0, it shall be taken as 1.0.

Table C3 provides external pressure coefficients for circular arc roofs with no substantial interference to the airflow over the roof. Where a ridge ventilator of a height at least 5% of the total height of the roof is present, the external pressure coefficient on the central half of the roof (T) shall be modified by adding +0.3; that is, the value of a negative coefficient (suction) is reduced by 0.3. Such reductions shall not be made for the wind direction along the axis of the roof, for which the ridge ventilator has little effect on the airflow and resulting external pressures.

All combinations of external pressure coefficients on U, T and D shall be checked.

TABLE C3
EXTERNAL PRESSURE COEFFICIENTS ($C_{p,e}$)—CURVED ROOFS

Rise-to-span ratio (r/d)	Windward quarter (U)	Centre half (T)	Leeward quarter (D)
0.18	$(0.3 - 0.4 h/r)$ or 0.0	$-(0.55 + 0.2 h/r)$	$-(0.25 + 0.2 h/r)$ or 0.0
0.5	$(0.5 - 0.4 h/r)$ or 0.0		$-(0.1 + 0.2 h/r)$ or 0.0

NOTES:

- 1 h is the average roof height and r is the rise of the arch (see Figure C3).
- 2 For intermediate values of rise to span ratio, linear interpolation shall be used.
- 3 For $h/r > 2$, Table C3 shall be applied with $h/r = 2$.
- 4 For $r/d < 0.18$, Table 5.3(A) shall be applied.

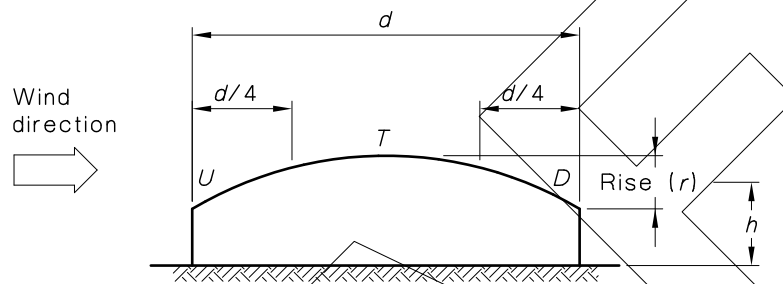

FIGURE C3 EXTERNAL PRESSURE COEFFICIENTS ($C_{p,e}$)—CURVED ROOFS

C4 MANSARD ROOFS

The external pressure coefficients ($C_{p,e}$) for a flat-topped mansard roof (see Figure C4) for the wind direction $\theta = 0^\circ$ shall be determined as follows:

- (a) For upwind slope (U)—using values for upwind slope given in Clause 5.4.1.
- (b) For downwind slope (D)—using values for downwind slope given in Clause 5.4.1, using the same roof pitch α as for the upwind slope.
- (c) For flat top (T)—using the same values as determined for downwind slope.

The external pressure coefficients ($C_{p,e}$) for the wind direction $\theta = 90^\circ$ shall be determined from Clause 5.4.1 assuming R for gable roofs.

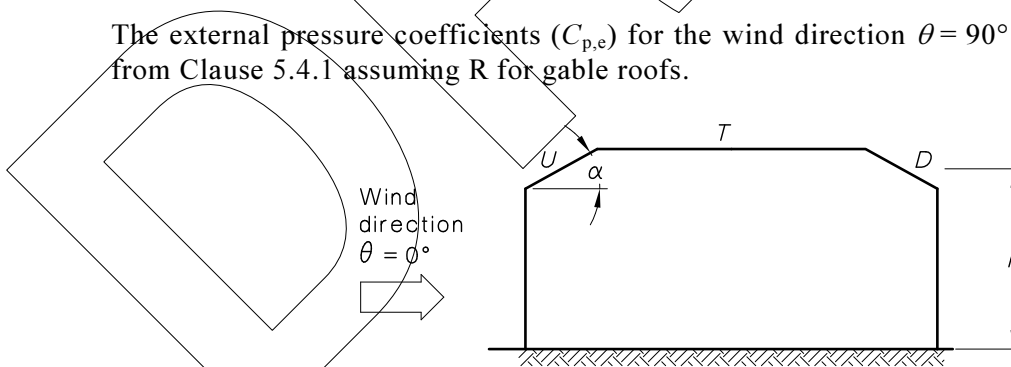

FIGURE C4 EXTERNAL PRESSURE COEFFICIENTS ($C_{p,e}$) FOR MANSARD ROOFS

C5 CIRCULAR BINS, SILOS AND TANKS

C5.1 General

Grouped circular bins, silos and tanks with spacing between walls greater than two diameters shall be treated as isolated silos. Closely spaced groups with spacing less than 0.1 diameters shall be treated as a single structure for wind actions and pressure determined using Tables 5.2 and 5.3. For intermediate spacings, linear interpolation shall be used.

C5.2 Isolated circular bins, silos and tanks

C5.2.1 Walls

The aerodynamic shape factor (C_{fig}) for calculating external pressures on the walls of bins, silos and tanks of circular cross-section shall be equal to the external pressure coefficients ($C_{p,b}$) as a function of the angle θ_b (see Figure C5), given as follows for shapes in the ranges indicated:

$$C_{p,b}(\theta_b) = k_b C_{p1}(\theta_b) \quad \dots \text{C5(1)}$$

where

the cylinder is standing on the ground or supported by columns of a height not greater than the height of the cylinder (c), c/b is in the range 0.25 to 4.0 inclusive

θ_b = angle from the wind direction to a point on the wall of a circular bin, silo or tank, in degrees

k_b = factor (or function) for a circular bin, given as follows:

$$\begin{aligned} &= 1.0 && \text{for } C_{p1} \geq -0.15, \text{ or} \\ &= 1.0 - 0.55(C_{p1}(\theta_b) + 0.15) \log_{10}(c/b) && \text{for } C_{p1} < -0.15 \end{aligned} \quad \dots \text{C5(2)}$$

$$C_{p1}(\theta_b) = -0.5 + 0.4 \cos \theta_b + 0.8 \cos^2 \theta_b + 0.3 \cos^3 \theta_b - 0.1 \cos^4 \theta_b - 0.05 \cos^5 \theta_b \quad \dots \text{C5(3)}$$

For calculating the overall drag force on the wall section of circular bins, silos and tanks (both elevated and on ground) C_{fig} shall be taken as 0.63 (based on an elevation area $b \times c$). This drag force coefficient arises from an integration of the along-wind component of the normal pressures given by Equations C5(2) and C5(3).

External pressure coefficients for the underside of elevated bins, silos and tanks shall be calculated as for elevated enclosed rectangular buildings (see Clause 5.4.1).

Figure C6 is a graphical presentation of the external pressure coefficient (C_{p1}) for circular bins, silos and tanks of unit aspect ratio (i.e., $c/b = 1.0$) at individual locations around the perimeter, and θ_b degrees from the incident wind direction as calculated from Equation C5(1).

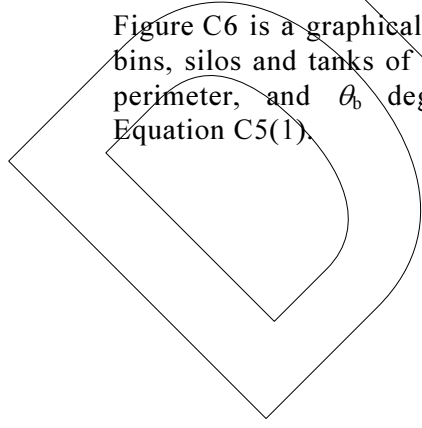

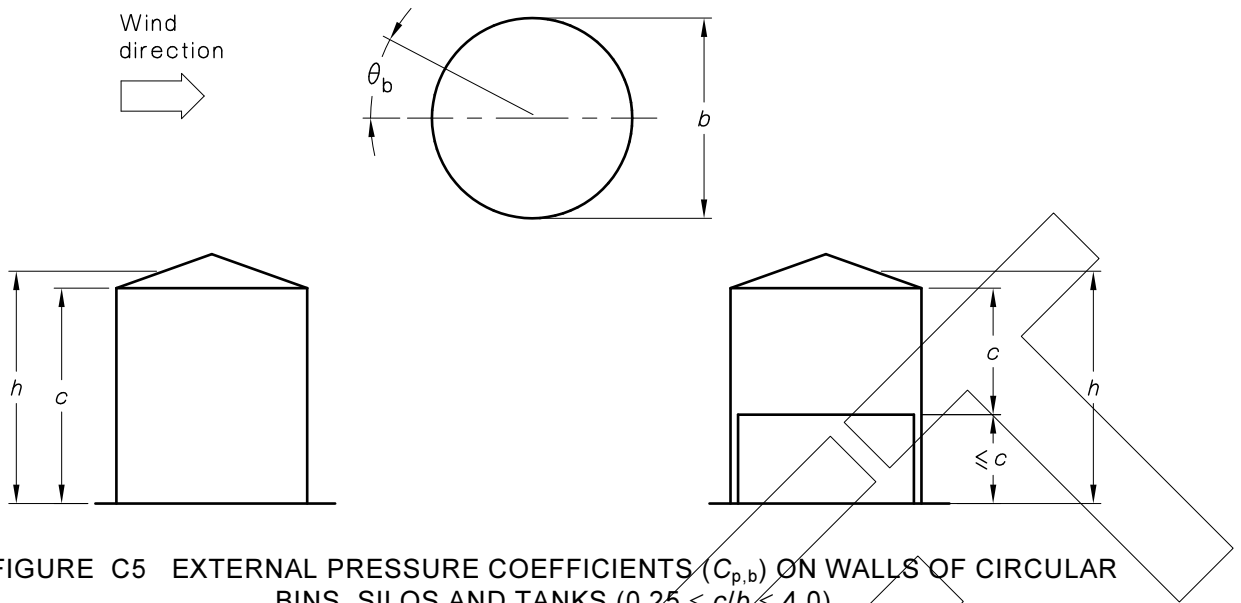

FIGURE C5 EXTERNAL PRESSURE COEFFICIENTS ($C_{p,b}$) ON WALLS OF CIRCULAR BINS, SILOS AND TANKS ($0.25 \leq c/b \leq 4.0$)

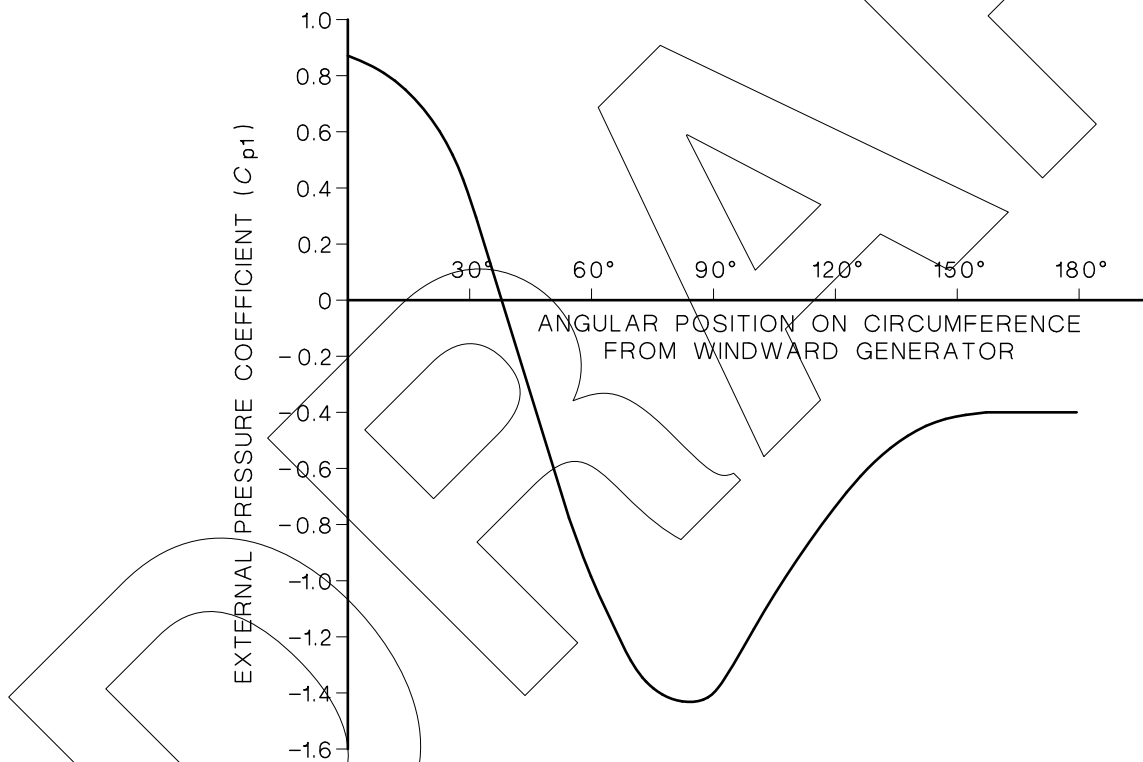

FIGURE C6 PLOT OF EXTERNAL PRESSURE COEFFICIENTS (C_{p1}) ON WALLS OF CIRCULAR BINS, SILOS AND TANKS ($c/b = 1$)

C5.2.2 Roofs and lids

The aerodynamic shape factor (C_{fig}) for calculating external pressures on the roofs or lids of bins, silos or tanks of circular cross-section, as shown in Figure C7, shall be as follows:

$$C_{fig} = C_{p,e} K_a K_l \dots C5(4)$$

where $C_{p,e}$ is given in Table C7 for zones A and B as shown in Figure C7, K_a is given in Clause 5.4.2 and K_l is given in Clause 5.4.4.

The local pressure factor (K_l) is applicable to the windward edges of roofs with slope less than or equal to 30° , and to the region near the cone apex for roofs with slope greater than 15° . The applicable areas are shown in Figure C7.

TABLE C7
EXTERNAL PRESSURE COEFFICIENTS
($C_{p,e}$) FOR ROOFS OF CIRCULAR BINS,
SILOS AND TANKS

Zone A	Zone B
-0.8	-0.5

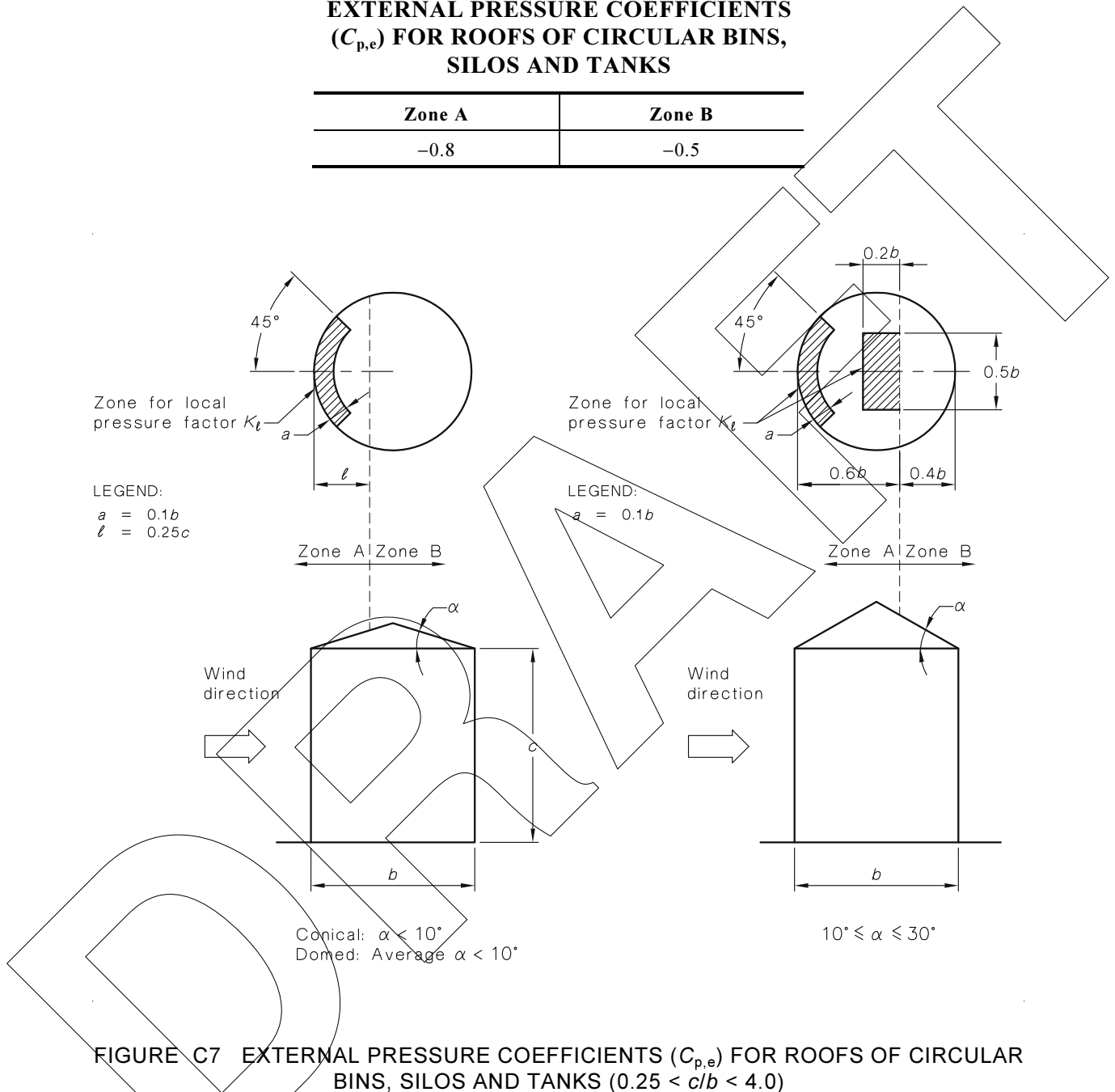

C5.2.3 Internal pressures in bins, silos and tanks

Internal pressures within bins, silos and tanks with vented roofs shall be determined as an area-weighted average of the external pressures at the position of the vents and openings, determined according to Paragraph C5.2.2.

For open-top bins, silos or tanks, the internal pressure shall be determined as follows:

$$C_{fig} = C_{p,i} \dots C5(5)$$

$$= -0.9 - 0.35 \log_{10}(c/b)$$

APPENDIX D
 FREESTANDING WALLS, HOARDINGS AND CANOPIES
 (Normative)

D1 GENERAL

D1.1 Application

This Appendix shall be used to calculate aerodynamic shape factors (C_{fig}) for the following structures and structural elements:

- (a) Free roofs, including hyperbolic paraboloid roofs.
- (b) Canopies, awnings and carports (adjacent to enclosed buildings).
- (c) Cantilevered roofs.
- (d) Hoardings and freestanding walls.

To calculate forces on the structure, use the area of the structure (one side only) as the reference area for normal pressures, and use the area of all the affected sides as the reference area for frictional pressure.

D1.2 Area reduction factor (K_a)

For the design of freestanding roofs and canopies, the area reduction factor (K_a) shall be as defined in Clause 5.4.2. For all other cases in this Appendix, $K_a = 1.0$.

D1.3 Local net pressure factor (K_l)

For the design of cladding elements and elements that offer immediate support to the cladding in free roofs and canopies, the values of local net pressure factor (K_l) given in Table D1 shall be used. For other elements in free roofs and canopies and for all other cases in this Appendix, $K_l = 1.0$.

TABLE D1
LOCAL NET PRESSURE FACTORS (K_l) FOR OPEN STRUCTURES

Case	Description	Local net pressure factor (K_l)
1	Pressures on an area between 0 and $1.0a^2$ within a distance $1.0a$ from a roof edge, or a ridge with a pitch of 10° or more	1.5
2	Pressures on an area of $0.25a^2$ or less, within a distance $0.5a$ from a roof edge, or a ridge with a pitch of 10° or more	2.0
3	Upward net pressures on an area of $0.25a^2$ or less, within a distance $0.5a$ from a windward corner of a free roof with a pitch of less than 10°	3.0

NOTES:

- 1 Where a is 20% of the shortest horizontal plan dimension of the free roof or canopy. For intermediate values of rise to span ratio, linear interpolation shall be used.
- 2 If an area of cladding is covered by more than one case in the above Table, the largest value of K_l shall be used.

Licensed to Mr timothy Messer on 3 November 2009. Personal use licence only. Storage, distribution or use on network prohibited.

D1.4 Net porosity factor (K_p)

For freestanding hoardings and walls, the net porosity factor (K_p) shall be as calculated in equation D1. For all other cases in this Appendix, $K_p = 1.0$.

$$K_p = 1 - (1 - \delta)^2 \quad \dots D1$$

where

δ = solidity ratio of the structure (surface or open frame), which is the ratio of solid area to total area of the structure

D2 FREESTANDING HOARDINGS AND WALLS

D2.1 Aerodynamic shape factor for normal net pressure on freestanding hoardings and walls

The aerodynamic shape factor (C_{fig}) for calculating net pressure across freestanding rectangular hoardings or walls (see Figure D1) shall be as follows:

$$C_{fig} = C_{p,n} K_p \quad \dots D2$$

where

$C_{p,n}$ = net pressure coefficient acting normal to the surface, obtained from Table D2 using the dimensions defined in Figure D1

K_p = net porosity factor, as given in Paragraph D1.4

NOTES:

- 1 The factors K_a and K_l do not appear in this equation as they are taken as 1.0.
- 2 Height for calculation of $V_{des,\theta}$ is the top of the hoarding or wall i.e. height (h) (see Figure D1).

Pressures derived from Equation D2 shall be applied to the total area (gross) of the hoarding or wall (for example $b \times c$).

The resultant of the pressure shall be taken to act at half the height of the hoarding, ($h - c/2$), or wall, ($c/2$), with a horizontal eccentricity (e).

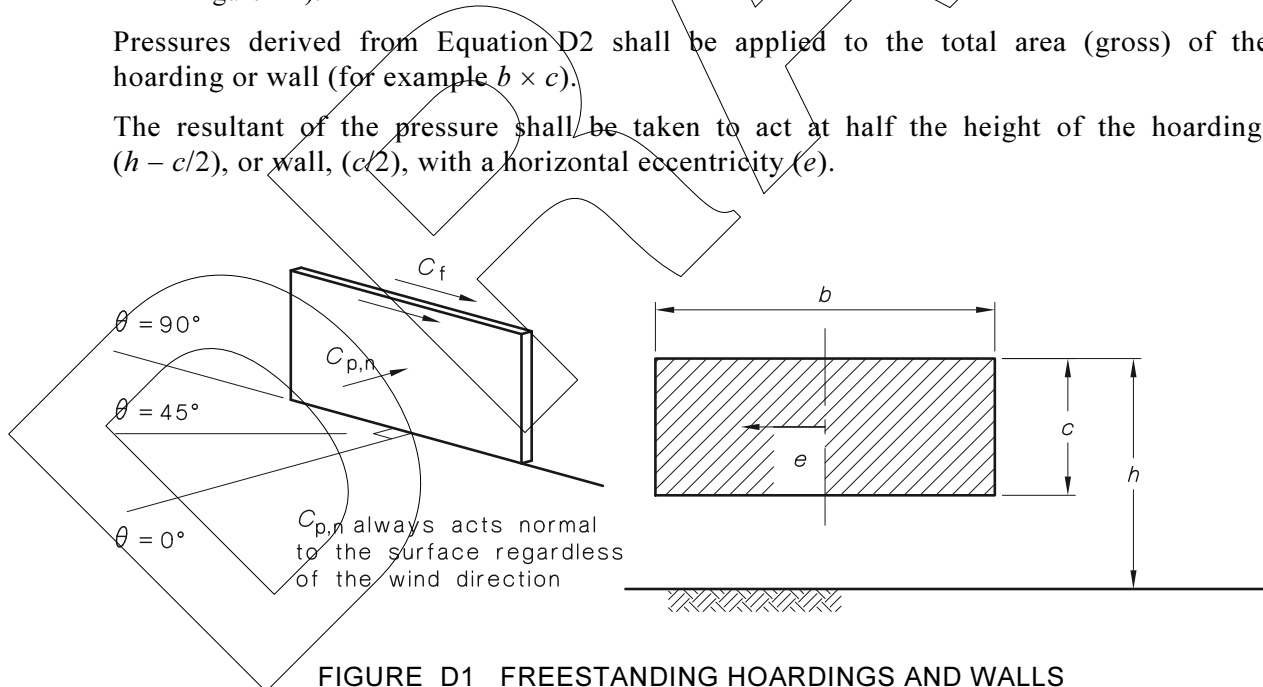

FIGURE D1 FREESTANDING HOARDINGS AND WALLS

TABLE D2(A)

NET PRESSURE COEFFICIENTS ($C_{p,n}$)—HOARDINGS AND FREESTANDING WALLS—WIND NORMAL TO HOARDING OR WALL, $\theta = 0^\circ$

b/c	c/h	$C_{p,n}$	e
0.5 to 5	0.2 to 1	$1.3 + 0.5(0.3 + \log_{10}(b/c))(0.8 - c/h)$	0
> 5		$1.7 - 0.5 c/h$	0
all	<0.2	$1.4 + 0.3\log_{10}(b/c)$	0

TABLE D2(B)

NET PRESSURE COEFFICIENTS ($C_{p,n}$)—HOARDINGS AND FREESTANDING WALLS—WIND AT 45° TO HOARDING OR WALL, $\theta = 45^\circ$

b/c	c/h	$C_{p,n}$	e
0.5 to 5 inclusive	0.2 to 1	$1.3 + 0.5(0.3 + \log_{10}(b/c))(0.8 - c/h)$	0.2b
	<0.2	$1.4 + 0.3\log_{10}(b/c)$	0.2b

TABLE D2(C)

NET PRESSURE COEFFICIENTS ($C_{p,n}$)—HOARDINGS AND FREESTANDING WALLS—WIND AT 45° TO HOARDING OR WALL, $\theta = 45^\circ$

b/c	c/h	Distance from windward free end	$C_{p,n}$ (see Note)
>5	≤ 0.7	0 to $2c$	3.0
		$2c$ to $4c$	1.5
		$>4c$	0.75
	> 0.7	0 to $2h$	2.4
		$2h$ to $4h$	1.2
		$>4h$	0.6

NOTE: Where a return wall or hoarding forms a corner extending more than $1c$, the $C_{p,n}$ on 0 to $2c$ for a hoarding shall be 2.2, and 0 to $2h$ for a wall $C_{p,n}$ shall be 1.8.

TABLE D2(D)

NET PRESSURE COEFFICIENTS ($C_{p,n}$)—HOARDINGS AND FREESTANDING WALLS—WIND PARALLEL TO HOARDING OR WALL, $\theta = 90^\circ$

b/c	c/h	Distance from windward free end	$C_{p,n}$ (see Note)
all	≤ 0.7	0 to $2c$	± 1.2
		$2c$ to $4c$	± 0.6
		$>4c$	± 0.3
	> 0.7	0 to $2h$	± 1.0
		$2h$ to $4h$	± 0.25
		$>4h$	± 0.25

NOTE: Take values of $C_{p,n}$ of the same sign.

Licensed to Mr timothy Messer on 3 November 2009. Personal use licence only. Storage, distribution or use on network prohibited.

D2.2 Aerodynamic shape factor for frictional drag

The aerodynamic shape factor (C_{fig}) for calculating frictional drag effects on freestanding hoardings and walls, where the wind is parallel to the hoarding or wall, shall be equal to C_f , which shall be determined as given in Table D3. The frictional drag on both surfaces shall be calculated and summed and added to the force on any exposed members calculated in accordance with Appendix E.

**TABLE D3
FRICTIONAL DRAG COEFFICIENT (C_f)**

Surface description	C_f
Surfaces with ribs across the wind direction	0.04
Surfaces with corrugations across the wind direction	0.02
Smooth surfaces without corrugations or ribs or with corrugations or ribs parallel to the wind direction	0.01

D3 FREE ROOFS AND CANOPIES

D3.1 Aerodynamic shape factor for net pressure on free roofs

The aerodynamic shape factor (C_{fig}) for calculating net pressures normal to free roofs of monoslope, pitched or troughed configuration shall be as follows:

$$C_{fig} = C_{p,n} K_a K_l \quad \dots D3$$

where

$C_{p,n}$ = net pressure coefficient acting normal to the surface, obtained for the windward half of a free roof ($C_{p,w}$) or net pressure coefficient for the leeward half of a free roof ($C_{p,l}$) as given in Tables D4 to D7 for roofs within the geometrical limits given (positive indicates net downward pressure)

K_a = area reduction factor, as given in Paragraph D1.2

K_l = local pressure factor, as given in Paragraph D1.3

NOTE: The factor K_p does not appear in this equation as it is taken as 1.0.

For free roofs of low pitch with fascia panels, the fascia panel shall be treated as the wall of an elevated building, and the C_{fig} found from Clause 5.4.

In Tables D4, D5, D6 and D7, 'empty under' implies that any goods or materials stored under the roof, block less than 50% of the cross-section exposed to the wind. 'Blocked under' implies that goods or materials stored under the roof block more than 75% of the cross-section exposed to the wind.

To obtain intermediate values of blockage and roof slopes other than those shown, use linear interpolation. Interpolation shall be carried out only between values of the same sign. Where no value of the same sign is given, for interpolation purposes 0.0 shall be assumed.

Where alternative pressure coefficient values are listed in Tables D4(A), D4(B), D5 and D6, for the appropriate roof slope, blockage and wind direction, all combinations of values $C_{p,w}$ and $C_{p,l}$ shall be considered.

For $\theta = 90^\circ$, with $0.25 \leq h/d \leq 1$ the roof pitch is effectively zero, and Table D4(A) with $\alpha = 0^\circ$ shall be used to determine $C_{p,n}$.

Licensed to Mr timothy Messer on 3 November 2009. Personal use licence only. Storage, distribution or use on network prohibited.

TABLE D4(A)
NET PRESSURE COEFFICIENTS ($C_{p,n}$) FOR
MONOSLOPE FREE ROOFS— $0.25 \leq h/d \leq 1$ (see Figure D2)

Roof pitch (α) degrees	$\theta = 0$ degrees				$\theta = 180$ degrees			
	$C_{p,w}$		$C_{p,l}$		$C_{p,w}$		$C_{p,l}$	
	Empty under	Blocked under	Empty under	Blocked under	Empty under	Blocked under	Empty under	Blocked under
0	-0.3, 0.4	-1.0, 0.4	-0.4, 0.0	-0.8, 0.4	-0.3, 0.4	-1.0, 0.4	-0.4, 0.0	-0.8, 0.4
15	-1.0	-1.5	-0.6, 0.0	-1.0, 0.2	0.8	0.8	0.4	-0.2
30	-2.2	-2.7	-1.1, -0.2	-1.3, 0.0	1.6	1.6	0.8	0.0

TABLE D4(B)
NET PRESSURE COEFFICIENTS ($C_{p,n}$) FOR
MONOSLOPE FREE ROOFS— $0.05 \leq h/d < 0.25$ (see Figure D2)

Conditions	h/d	Horizontal distance (x) from windward edge	Net pressure coefficients ($C_{p,n}$)
For $\alpha \leq 5^\circ$, or For all α with $\theta = 90^\circ$	$0.05 \leq h/d < 0.25$	$x \leq 1h$	Values given for $C_{p,w}$ in Table D4(A), for $\alpha = 0^\circ$
		$1h < x \leq 2h$	Values given for $C_{p,l}$ in Table D4(A), for $\alpha = 0^\circ$
		$x > 2h$	-0.2, 0.2 for empty under -0.4, 0.2 for blocked under

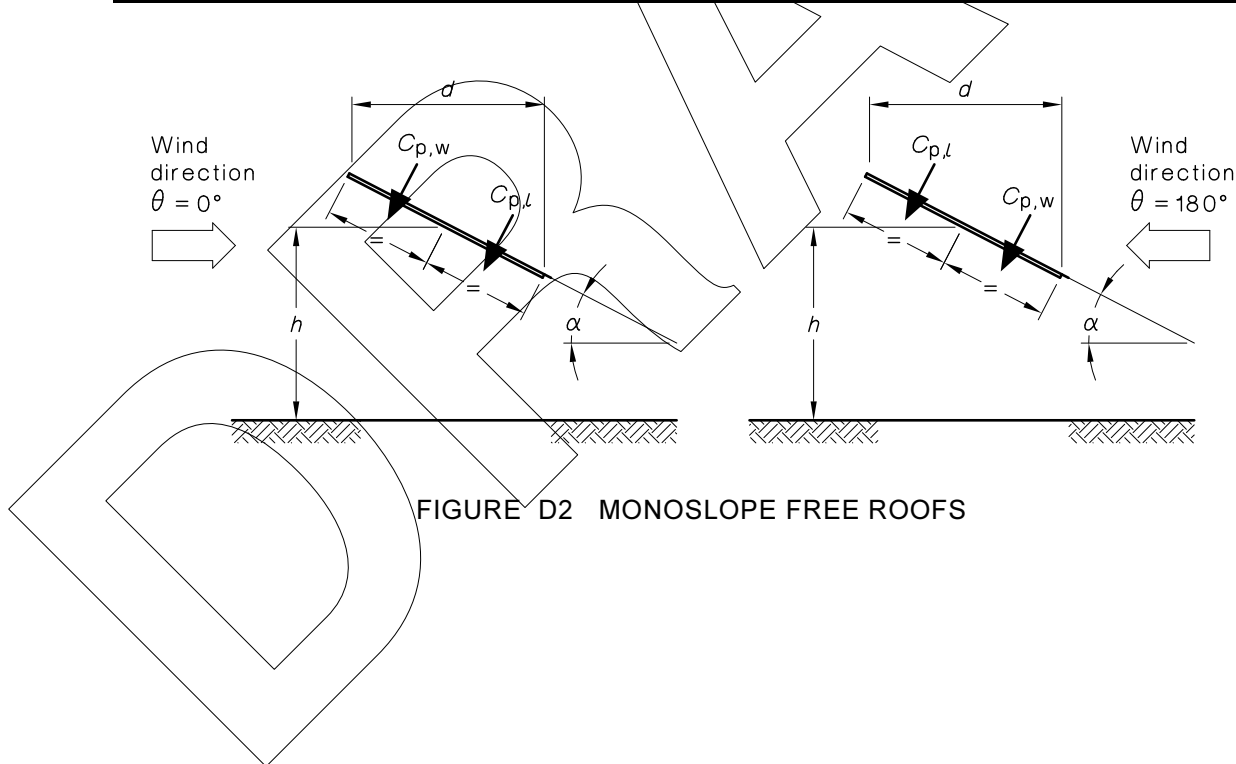

FIGURE D2 MONOSLOPE FREE ROOFS

TABLE D5
NET PRESSURE COEFFICIENTS ($C_{p,n}$) FOR
PITCHED FREE ROOFS— $0.25 \leq h/d \leq 1$ (see Figure D3)

Roof pitch (α) degrees	$\theta = 0^\circ$			
	$C_{p,w}$		$C_{p,l}$	
	Empty under	Blocked under	Empty under	Blocked under
≤ 15	-0.3, 0.4	-1.2	-0.4, 0.0	-0.9
22.5	-0.3, 0.6	-0.9	-0.6, 0.0	-1.1
30	-0.3, 0.8	-0.5	-0.7, 0.0	-1.3

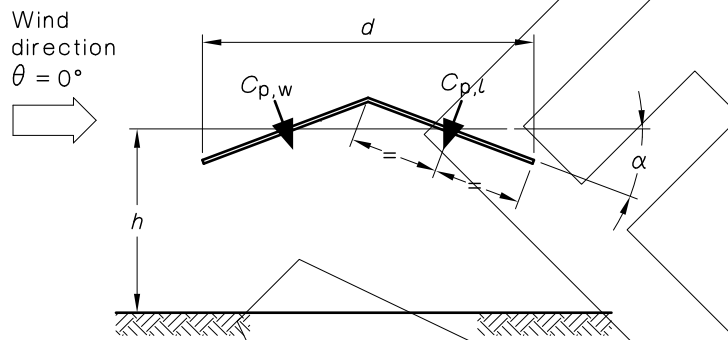

FIGURE D3 PITCHED FREE ROOFS

TABLE D6
NET PRESSURE COEFFICIENTS ($C_{p,n}$) FOR
TROUGHED FREE ROOFS— $0.25 \leq h/d \leq 1$ (see Figure D4)

Roof pitch (α) degrees	$\theta = 0^\circ$			
	$C_{p,w}$		$C_{p,l}$	
	Empty under	Blocked under	Empty under	Blocked under
7.5	-0.6, 0.4	-0.7	0.3	-0.3
15	-0.6, 0.4	-0.8	0.5	-0.2
22.5	-0.7, 0.3	-1.0	0.7	-0.2

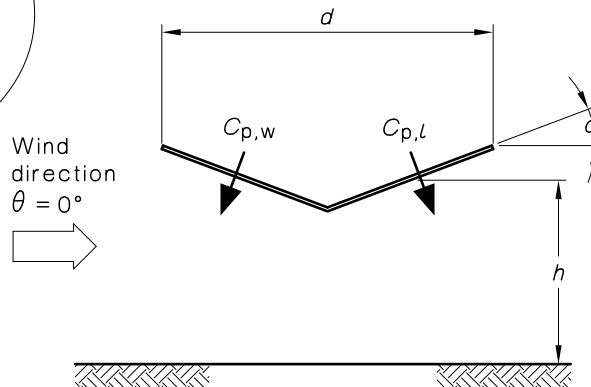

FIGURE D4 TROUGHED FREE ROOFS

TABLE D7
NET PRESSURE COEFFICIENTS ($C_{p,n}$) FOR
HYPAR FREE ROOFS—EMPTY UNDER (see Figure D5)

Conditions	θ , degrees	$C_{p,w}$	$C_{p,l}$
Empty under, $0.25 < h/d < 0.5$, $0.1 < c/d < 0.3$, and $0.75 < b/d < 1.25$	0	+0.45	+0.25
		-0.45	-0.25
	90	+0.45	+0.25
		-0.45	-0.25

NOTE: $C_{p,n}$ is defined as positive downwards, and only combinations of values of the same sign need to be considered.

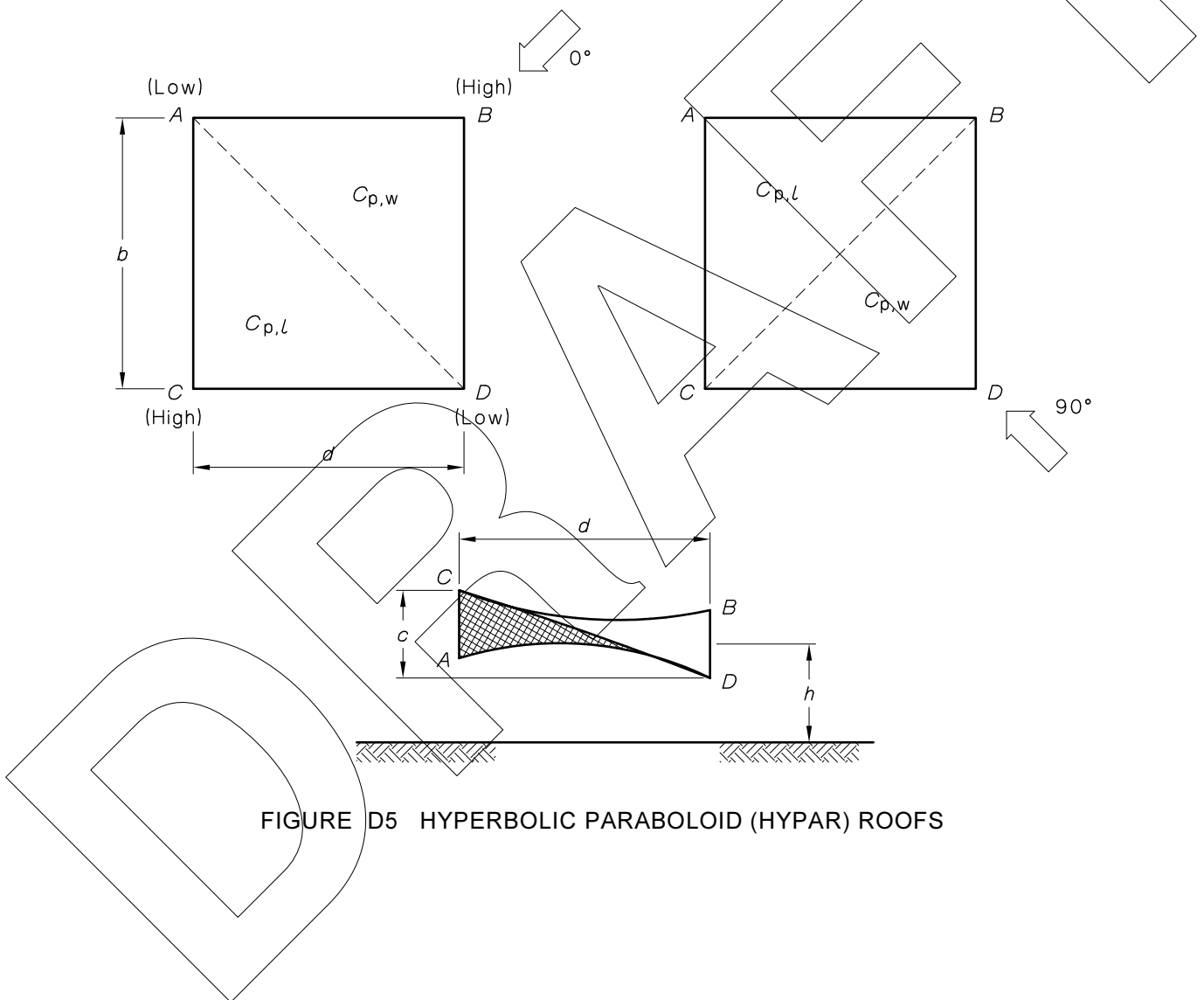

FIGURE D5 HYPERBOLIC PARABOLOID (HYPAR) ROOFS

D3.2 Aerodynamic shape factor for frictional drag and drag on exposed members for free roofs

The aerodynamic shape factor (C_{fig}) for calculating frictional drag on free roofs of monoslope, pitched or troughed configuration shall be equal to C_f calculated as given in Table D3. For free roofs, the frictional drag on both upper and lower surfaces shall be calculated and added to the drag on any exposed members calculated in accordance with Appendix E (see Clause 2.5).

Calculation of frictional drag pressure is not required for wind directions of 0° or 180° , as shown in Figures D2, D3 and D4, for free roofs with pitches of 10° or more.

D4 ATTACHED CANOPIES, AWNINGS AND CARPORTS (ROOFS)

D4.1 Aerodynamic shape factor for net pressure on attached canopies

The aerodynamic shape factor (C_{fig}) for calculating net pressures normal to the roof on canopies, awnings or carports adjacent to enclosed buildings and with a roof slope of 10° or less shall be calculated as follows:

$$C_{fig} = C_{p,n} K_a K_\ell$$

... D4

where

$C_{p,n}$ = net pressure coefficient acting normal to the surface, as given in Tables D8 and D9

K_a = area reduction factor, as given in Paragraph D1.2

K_ℓ = local pressure factor, as given in Paragraph D1.3

NOTES:

- 1 The values given for $C_{p,n}$ assume that any goods and materials stored under the canopy do not represent more than a 75% blockage.
- 2 The factor K_p does not appear in this equation as it is taken as 1.0.

Where indicated, attached canopies, awnings or carports shall be designed for both downward (positive) and upward (negative) net wind pressures.

For wind directions normal to the attached wall ($\theta = 0$ degrees), for canopies and awnings, $C_{p,n}$ shall be taken from Tables D8 or D9 with reference to Figure D6. All pressure coefficients shall be used with the value of wind speed applying at average roof height (h) and h_c is the average height of the canopy above ground.

For wind directions parallel to the wall of the attached building ($\theta = 90^\circ$ or 270°), the canopy or awning shall be considered as a free roof and the net pressure coefficients ($C_{p,n}$) shall be obtained in accordance with Table D4(A) or D4(B) or, where the canopy is partially enclosed, from Table D9.

TABLE D8
NET PRESSURE COEFFICIENTS ($C_{p,n}$) FOR CANOPIES AND AWNINGS
ATTACHED TO BUILDINGS (see Figure D6(a)) FOR $\theta = 0^\circ$

Design case	h_c/h (see Note 1)	Net pressure coefficients ($C_{p,n}$)
$h_c/h < 0.5$	0.1	1.2, -0.2
	0.2	0.7, -0.2
	0.5	0.4, -0.2
$h_c/h \geq 0.5$	0.5	0.5, -0.3
	0.75	0.4, $[-0.3 - 0.2(h_c/w_c)]$ or -1.5 (see Note 2)
	1.0	0.2, $[-0.3 - 0.6(h_c/w_c)]$ or -1.5 (see Note 2)

NOTES:

- 1 For intermediate values of h_c/h , linear interpolation shall be used.
- 2 Whichever is the lower magnitude.

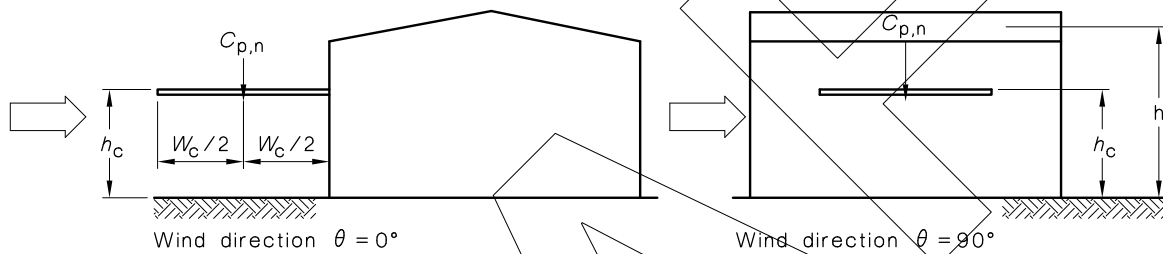

(a) Open canopy or awning

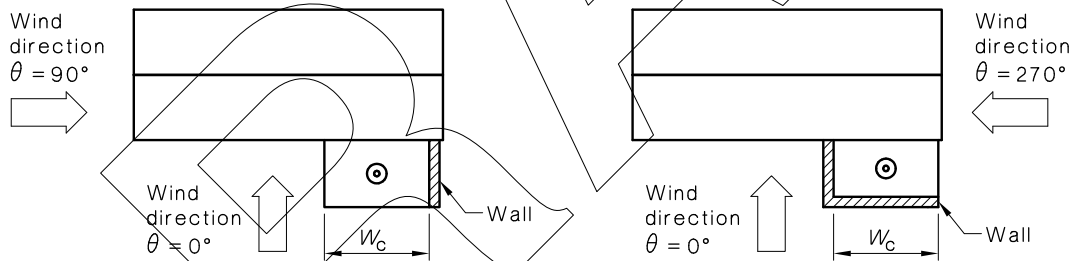

(b) Wall on one side, from building

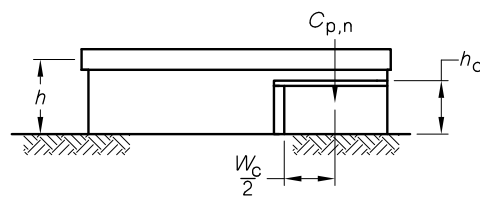

(c) Wall on two sides

FIGURE D6 NET PRESSURE COEFFICIENTS ($C_{p,n}$) FOR CANOPIES, AWNINGS AND CARPORTS ATTACHED TO BUILDINGS

TABLE D9
NET PRESSURE COEFFICIENTS ($C_{p,n}$) FOR
PARTIALLY ENCLOSED CARPORTS (see Figures D6(b) and D6(c))

Conditions	Partially enclosed	Wind direction (θ), degrees	Net pressure coefficients ($C_{p,n}$)
$h_c/w_c \leq 0.5$ and $h_c/h < 0.8$	Wall on one side attached to building, see Figure D6(b)	0	-0.7
		90	-1.0
	Wall on two sides, see Figure D6(c)	0	-0.6
		270	-1.2

D4.2 Aerodynamic shape factor for frictional drag and drag on exposed members of attached canopies

The aerodynamic shape factor (C_{fig}) for calculating frictional drag effects on attached canopies, awnings or carport roofs, where the wind is parallel to the attached wall, shall be equal to C_f as given in Table D3. For canopies, the frictional drag on both upper and lower surfaces shall be calculated and added to the drag on any exposed members calculated in accordance with Appendix E (see Clause 2.5).

D5 CANTILEVERED ROOFS

For an isolated cantilever roof with no interference from upstream structures within six roof heights the aerodynamic shape factors ($C_{fig,1}$, $C_{fig,2}$) for structural loading of main supporting members is given in Table D10, with reference to Figure D7.

TABLE D10
AERODYNAMIC SHAPE FACTOR FOR CANTILEVERED ROOFS

Isolated cantilever roof with roof pitch with $-7^\circ < \alpha < 7^\circ$					
$\theta = 0^\circ$					
Height/span		h/d < 1.4		h/d > 1.4	
Load direction	Bay position	$C_{fig,1}$	$C_{fig,2}$	$C_{fig,1}$	$C_{fig,2}$
Upward loading (-)	internal	-1.8	-1.1	-1.4	-1.4
	end	-1.3	-1.0	-1.9	-1.1
Downward loading (+)	internal	0.25	0.15	0.20	-0.15
	end	0.55	0.65	0.20	0.0
$\theta = 90^\circ$					
Use Table D4(B) for $\theta = 90^\circ$ for blocked under and $\alpha = 0^\circ$					
$\theta = 180^\circ$					
Use Table D4(A) for blocked under and $\alpha = 0^\circ$					

NOTES:

- For cladding loads on roofing elements, Paragraph D3 should be used, assuming blocked under.
- Wind tunnel testing or similar studies should be carried out if there is a similar height grandstand roof within six roof heights of the cantilevered roof in question.

Dynamic response shall be taken into account by determining the dynamic response factor (C_{dyn}) as follows:

- (a) For cases where beams are greater than 15 m long, $\left(\frac{V_{des,\theta}}{1 + g_v I_h} \right) \left(\frac{1}{n_1 d} \right) > 0.4$
and $n_1 < 1$ Hz;

$$C_{dyn} = \left(1.0 + 0.5 \left[\left(\frac{V_{des,\theta}}{1 + g_v I_h} \right) \left(\frac{1}{n_1 d} \right) - 0.4 \right] \right) \dots D5$$

where

n_1 = first mode frequency of vibration of the cantilevered roof in the vertical bending mode

(b) For all other cases, $C_{dyn} = 1.0$.

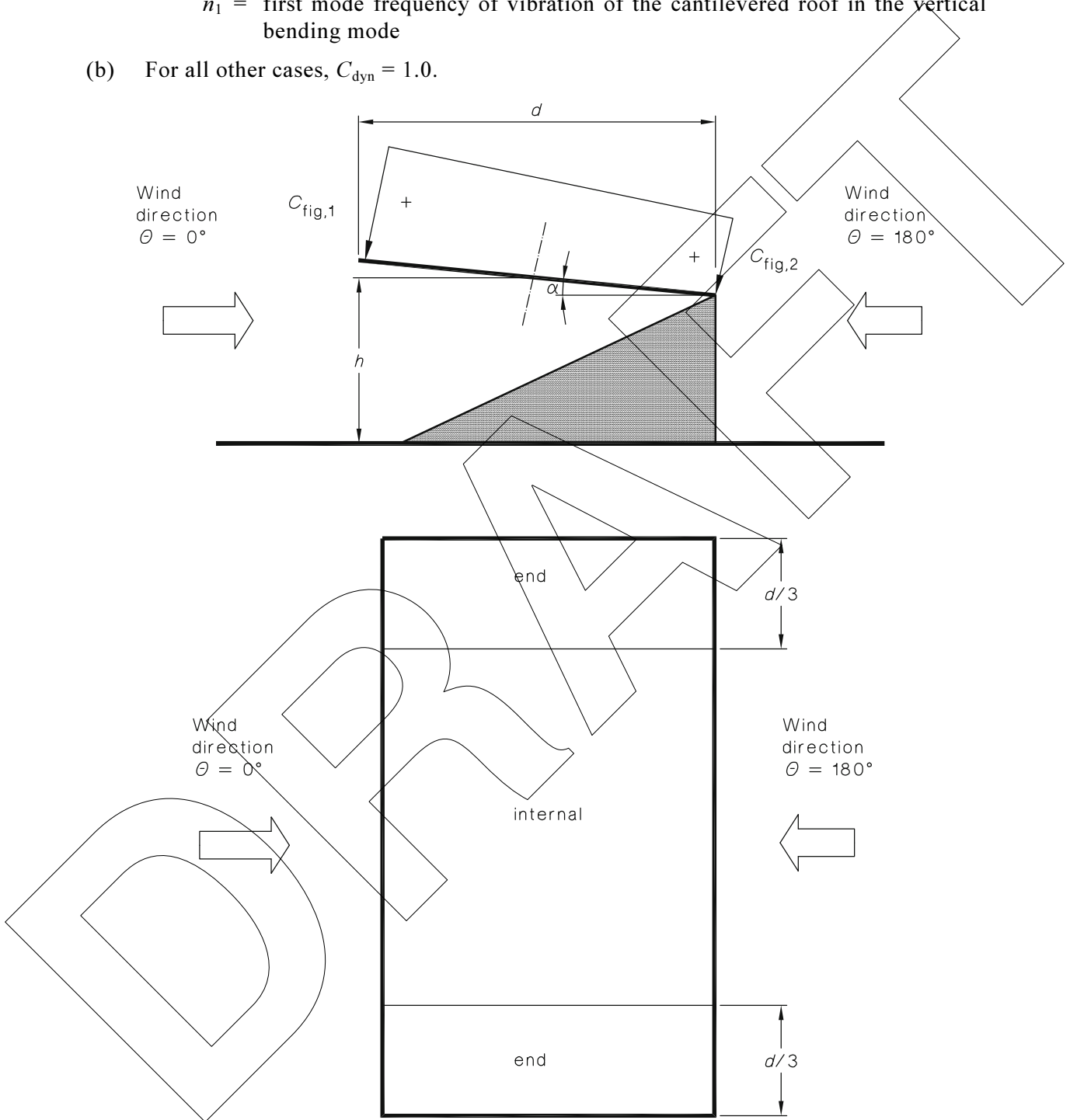

FIGURE D7 CANTILEVERED ROOF

APPENDIX E

AERODYNAMIC SHAPE FACTORS FOR EXPOSED STRUCTURAL MEMBERS, FRAMES AND LATTICE TOWERS

(Normative)

E1 GENERAL

This Appendix shall be used to calculate aerodynamic shape factors (C_{fig}) for structures and components consisting of exposed members, such as lattice frames, trusses and towers.

All pressure coefficients shall be used with the value of wind speed applying at the height of the component being considered.

E2 AERODYNAMIC SHAPE FACTORS FOR INDIVIDUAL MEMBERS AND FRAMES

E2.1 Simple shapes and individual members

The aerodynamic shape factor (C_{fig}) for individual exposed structural members, whose aspect ratio (l/b) is greater than 8, shall be calculated as follows:

(a) For wind axes:

$$C_{fig} = K_{ar} K_i C_d \quad \dots E2(1)$$

(b) For body axes:

$$C_{fig} = K_{ar} K_i C_{F,x} \text{ along member's x-axis (major axis)} \quad \dots E2(2)$$

$$C_{fig} = K_{ar} K_i C_{F,y} \text{ along member's y-axis (minor axis)} \quad \dots E2(3)$$

where

- l = length of member
- b = breadth of element, normal to the wind stream
- K_{ar} = aspect ratio correction factor for individual member forces, as given in Table E1
- K_i = factor to account for the angle of inclination of the axis of members to the wind direction, determined as follows:
 - = 1.0, when the wind is normal to the member
 - = $\sin^2 \theta_m$ for rounded cylindrical shapes
 - = $\sin \theta_m$ for sharp-edged prisms, (sharp-edged prisms are those with b/r greater than 16)
- θ_m = angle between the wind direction and the longitudinal axis of the member, in degrees
- r = corner radius of a structural shape
- C_d = drag force coefficient for a structure or member in the direction of the wind stream, as given in Paragraph E3
- $C_{F,x}$ and $C_{F,y}$ = drag force coefficients for a structure or member, in the direction of the x - and y -axes respectively, as given in Paragraph E3

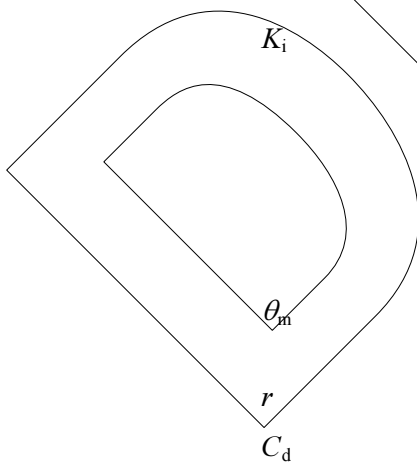

TABLE E1
ASPECT RATIO CORRECTION FACTORS (K_{ar})

Aspect ratio, l/b (see Note)	Correction factor K_{ar}
≤ 8	0.7
14	0.8
30	0.9
40 or more	1.0

NOTE: For intermediate values of l/b , use linear interpolation.

E2.2 Single open frame

The aerodynamic shape factor (C_{fig}) for a structure of open frame type, comprising a number of members where the members are sharp-edged rectangular or structural sections, lying in a single plane normal to the wind direction (see Figure E1), shall be taken as follows:

- (a) For $0.2 < \delta_e < 0.8$ and $1/3 < (l/b) < 3$ (where l/b is the aspect ratio of the whole frame).

$$C_{fig} = 1.2 + 0.26 (1 - \delta_e) \dots E2(4)$$

The reference area, A_{ref} , to be used in Equation E2(4) for an open frame shall be taken as the sum of the projected areas of all the members projected normal to the plane of the frame.

- (b) For all other cases, wind action shall be the sum of the effects calculated on individual members and attachments determined in accordance with Clause 2.5.3.3 and Paragraph E2.1.

where

- δ_e = effective solidity ratio for an open frame, given as follows:
 - = δ for flat-sided members
 - = $1.2\delta^{1.75}$ for circular cross-section members

where

- δ = solidity ratio of the structure (surface or open frame), which is the ratio of solid area to total area of the structure

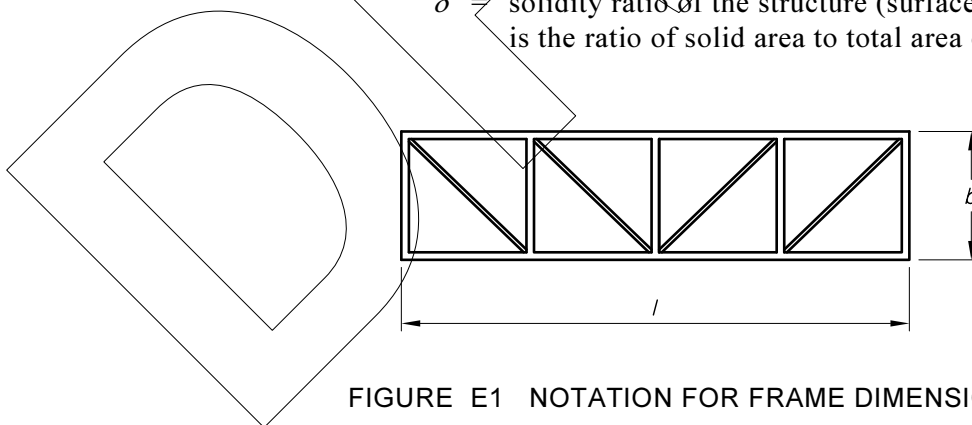

FIGURE E1 NOTATION FOR FRAME DIMENSIONS

E2.3 Multiple open frames

For structures comprising a series of similar open frames in parallel, the aerodynamic shape factors for the second and subsequent frames shall be taken as the aerodynamic shape factors on the windward frame calculated as in Paragraph E2.2, multiplied by the shielding factor (K_{sh}) obtained from Table E2. The aerodynamic shape factor (C_{fig}) for the structure shall be as follows:

$$C_{fig} = C_{fig,1} + \Sigma K_{sh} C_{fig,1} \dots E2(5)$$

where

$C_{fig,1}$ = aerodynamic shape factor for the first frame in the upwind direction, as given in Paragraph E2.2

K_{sh} = shielding factor for shielded frames in multiple open-framed structures, as given in Table E2

λ = spacing ratio for parallel open frames, equal to the frame spacing (centre-to-centre) divided by the smaller of l or b .

**TABLE E2
SHIELDING FACTORS (K_{sh}) FOR MULTIPLE FRAMES**

Angle of wind to frames (θ), degrees	Frame spacing ratio (λ)	Shielding factors (K_{sh})							
		Effective solidity (δ_e)							
		0	0.1	0.2	0.3	0.4	0.5	0.7	1.0
0 (wind normal to frames)	≤ 0.2	1.0	0.8	0.5	0.3	0.2	0.2	0.2	0.2
	0.5	1.0	1.0	0.8	0.6	0.4	0.2	0.2	0.2
	1.0	1.0	1.0	0.8	0.7	0.5	0.3	0.2	0.2
	2.0	1.0	1.0	0.9	0.7	0.6	0.4	0.2	0.2
	4.0	1.0	1.0	1.0	0.8	0.7	0.6	0.4	0.2
	≥ 8.0	1.0	1.0	1.0	1.0	1.0	1.0	1.0	1.0
45	≤ 0.5	1.0	0.9	0.8	0.7	0.6	0.5	0.3	0.3
	1.0	1.0	1.0	0.9	0.8	0.7	0.6	0.6	0.6
	2.0	1.0	1.0	1.0	1.0	1.0	0.9	0.8	0.6
	4.0	1.0	1.0	0.9	0.7	0.6	0.4	0.2	0.2
	≥ 8.0	1.0	1.0	1.0	1.0	1.0	1.0	1.0	1.0

NOTE: For intermediate values of δ_e and λ , linear interpolation shall be used.

E3 DRAG FACTORS FOR STRUCTURAL MEMBERS AND SIMPLE SECTIONS

E3.1 Rounded cylindrical shapes, sharp-edged prisms and structural sections

Values of drag force coefficients (C_d , $C_{F,x}$ and $C_{F,y}$) for rounded cylindrical shapes, sharp-edged prisms and some structural sections shall be as given in Tables E3, E4 and E5 respectively.

Table E4 gives values for the most common polygonal sharp-edged cross-sections except for rectangular prisms that are covered separately in Paragraph E3.2.

NOTES:

- 1 Drag force coefficients of sharp-edged section are independent of the Reynolds number.
- 2 Note that in Table E5, the dimension b , used in the definition of the force coefficients, is not always normal to the flow direction and d is not always parallel.

In the absence of experimental information for particular cables, C_d for helically wound, unwrapped cables shall be as follows:

- (a) 1.2 for $bV_{des,\theta} < 0.5m^2/s$.

(b) 1.0 for $bV_{des,\theta} > 5.0\text{m}^2/\text{s}$.

For values of $bV_{des,\theta}$ between 0.5 and 5.0, use interpolation.

Where icing of cables is considered, the increased cross-sectional area and changed shape shall be taken into account.

TABLE E3
DRAG FORCE COEFFICIENTS (C_d) FOR ROUNDED CYLINDRICAL SHAPES

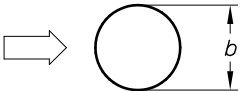
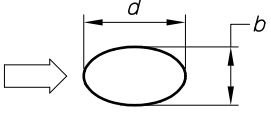
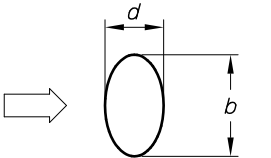
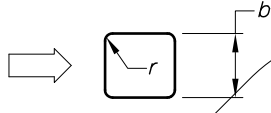
Cross-sectional shape	Description	Drag force coefficient (C_d) (see Note 1)	
		$bV_{des,\theta} < 4 \text{ m}^2/\text{s}$	$bV_{des,\theta} > 10 \text{ m}^2/\text{s}$
	Cylindrical	1.2	(see Note 2)
 Ellipse $\frac{b}{d} = \frac{1}{2}$	Ellipse narrow side to wind	0.7	0.3
 Ellipse $\frac{b}{d} = 2$	Ellipse broad side to wind	1.7	1.5
 $\frac{b}{d} = 1$ $\frac{r}{b} = \frac{1}{3}$	Square with rounded corners	1.2	0.6

NOTES:

- For intermediate values of $bV_{des,\theta}$, linear interpolation shall be used.
- For smooth circular cross-sections and polygonal sections with more than 16 sides, where $bV_{des,\theta} > 10 \text{ m}^2/\text{s}$, C_d shall be as follows:

$$C_d = 0.5 \quad \text{for } h_r/b \leq 0.00002$$

$$C_d = 1.6 + 0.105 \log_e (h_r/b) \quad \text{for } h_r/b > 0.00002$$

where



h_r = average height of surface roughness

Some typical values for h_r in millimetres are as follows:

- Glass, plastic: 0.0015
- Steel: galvanized 0.15; light rust 2.5; heavy rust 15
- Concrete, new smooth 0.06; new rough: 1.0
- Metal, painted: 0.03

- Significant attachments to circular cross-sections (e.g. ladders, pipes etc.) will induce aerodynamic separation and in these cases $C_d = 1.2$.
- Due consideration shall be taken of the projected area and drag of the attachments themselves.

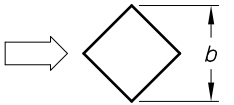
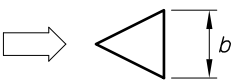
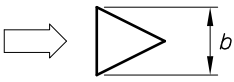
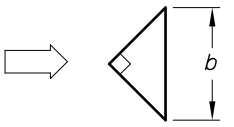
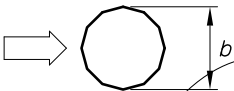
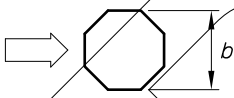
TABLE E4
DRAG FORCE COEFFICIENT (C_d) FOR SHARP-EDGED PRISMS

Cross-sectional shape		Drag force coefficient (C_d)
	Square with face to wind	2.2
	Square with corner to wind	1.5
	Equilateral triangle—apex to wind	1.2
	Equilateral triangle—face to wind	2.0
	Right angled triangle	1.55
	12-sided polygon	1.3
	Octagon	1.4
	Pentagon with face to wind	1.1
	Pentagon with corner to wind	1.7

Licensed to Mr timothy Messer on 3 November 2009. Personal use licence only. Storage, distribution or use on network prohibited.

TABLE E5
FORCE COEFFICIENTS ($C_{F,x}$) AND ($C_{F,y}$) FOR STRUCTURAL SECTIONS

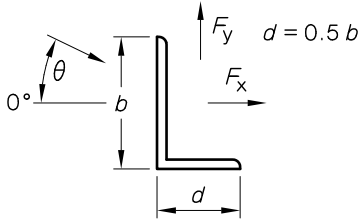
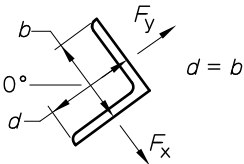
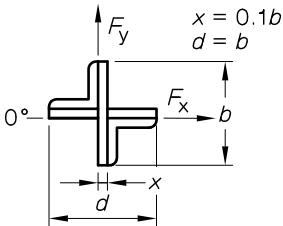
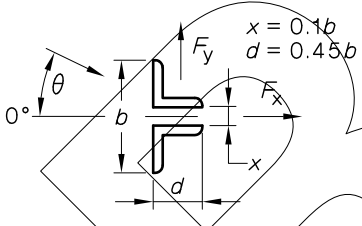
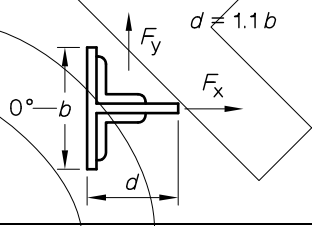
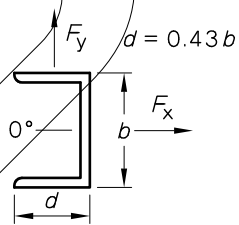
Section shape		Wind direction measured clockwise (θ)				
		0	45	90	135	180
	$C_{F,x}$	2.0	1.8	-2.0	-1.8	-1.9
	$C_{F,y}$	-0.1	0.1	-1.7	-0.8	-0.95
	$C_{F,x}$	1.8	1.8	-1.0	0.3	-1.4
	$C_{F,y}$	1.8	2.1	-1.9	-2.0	-1.4
	$C_{F,x}$	1.75	0.75	-0.1	-0.85	-1.75
	$C_{F,y}$	0.1	-0.75	-1.75	-0.85	-0.1
	$C_{F,x}$	1.6	1.5	-0.95	-0.5	-1.5
	$C_{F,y}$	0	0.1	-0.7	-1.05	0
	$C_{F,x}$	2.0	1.2	-1.6	-1.1	-1.7
	$C_{F,y}$	0	-0.9	-2.15	-2.4	± 2.1
	$C_{F,x}$	2.05	1.85	0	-1.6	-1.8
	$C_{F,y}$	0	-0.6	-0.6	-0.4	0

(continued)

TABLE E5 (continued)

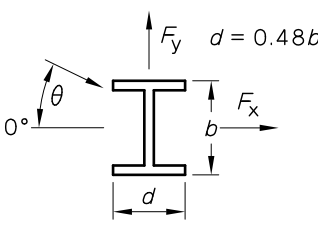
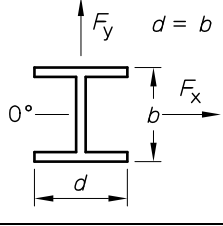
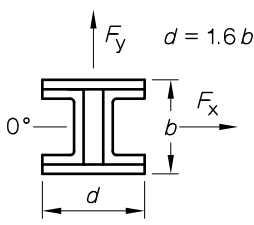
Section shape		Wind direction measured clockwise (θ)				
		0	45	90	135	180
	$C_{F,x}$	2.05	1.95	± 0.5	—	—
	$C_{F,y}$	0	-0.6	-0.9	—	—
	$C_{F,x}$	1.6	1.5	0	—	—
	$C_{F,y}$	0	-1.5	-1.9	—	—
	$C_{F,x}$	1.4	1.2	0	—	—
	$C_{F,y}$	0	-1.6	-2.2	—	—

NOTE: Note that the direction of θ has been changed to clockwise and the values transposed accordingly, to align with the clockwise direction used elsewhere in the Standard. Also, dimension b , used in the definitions of the force coefficients, is not always normal to the wind direction.

E3.2 Rectangular prismatic sections

Values of force coefficients ($C_{F,x}$ and $C_{F,y}$) for rectangular prismatic cross-sections are given in Figures E2(A) and E2(B). This Paragraph does not cover the case where the wind direction angle θ is greater than 20° . For intermediate values of d/b , use linear interpolation.

NOTE: Figure E2(B) contains maximum values of $C_{F,y}$ for angles within 20° of the directions parallel to the faces of the rectangle. Fluctuations in wind direction of up to 20° may occur in turbulent flow nominally parallel to one face.

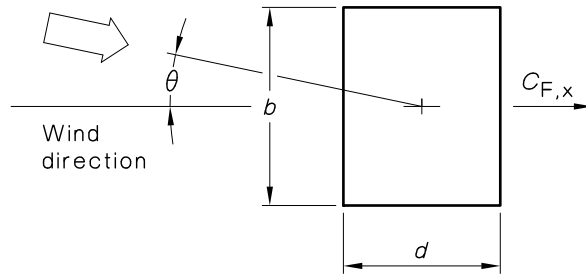

Aspect ratio d/b	Force coefficient ($C_{F,x}$)	Multiplying factor for $\theta \leq 15^\circ$
0.1	2.2	1.0
0.65	3.0	
1	2.2	
2	1.6	$[1 + (d/b)\tan\theta]$
4	1.3	
≥ 10	1.1	

FIGURE E2(A) ALONG-WIND COEFFICIENTS FOR RECTANGULAR PRISMS

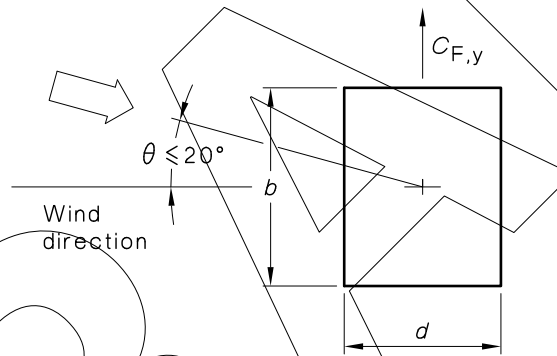

Aspect ratio d/b	Force coefficient ($C_{F,y}$)
0.5	± 1.2
1.5	± 0.8
2.5	± 0.6
4	± 0.8
≥ 20	± 1.0

FIGURE E2(B) CROSSWIND COEFFICIENTS FOR RECTANGULAR PRISMS

E4 LATTICE TOWERS

E4.1 General

Lattice towers shall be divided vertically into a series of sections (levels) and the aerodynamic shape factors (C_{fig}) shall be calculated for each section.

NOTE: A minimum of 10 sections should be used where possible.

They shall be designed for winds in 8 directions with $V_{des,\theta}$ being the value of $V_{sit,\beta}$ in a sector $\pm 22.5^\circ$ from the 45° direction being considered.

The aerodynamic shape factor (C_{fig}) shall be equal to the values calculated, as follows:

- (a) C_d for a tower section without ancillaries, as given in Paragraph E4.2.1.
- (b) C_{de} , for a tower section with ancillaries, as given in Paragraph E4.2.2.
- (c) $1.2 \sin^2 \theta_m$, for guy cables, using the wind speed calculated for 2/3 of the height of the cable

where

C_{de} = effective drag force coefficient for a tower section with ancillaries

θ_m = angle between the wind direction and the longitudinal axis of the member, in degrees

E4.2 Drag force coefficient

E4.2.1 Tower sections without ancillaries

The drag force coefficients (C_d) for complete lattice tower sections shall be taken from Tables E6(A) to E6(C).

For equilateral-triangle lattice towers with flat-sided members, the drag force coefficient (C_d) shall be assumed to be constant for any inclination of the wind to a face.

For complete clad tower sections, C_d shall be taken as the value given in Tables E3 and E4, and Figure E2 for the appropriate tower section shapes.

For UHF antenna sections, C_d shall be obtained from Table E7 and Figure E3. To calculate the area for the application of the pressure, breadth shall be taken as b_D or b_N , as appropriate to the wind direction.

Where used, the reduction for aspect ratio shall be carried out by multiplying by the correction factor (K_{ar}), given in Table E1, taking V as equal to two times the height of the end-mounted antennas.

TABLE E6(A)
DRAG FORCE COEFFICIENTS (C_d) FOR LATTICE TOWERS—SQUARE AND EQUILATERAL TRIANGLE IN PLAN WITH FLAT-SIDED MEMBERS

Solidity of front face (δ)	Square towers		Equilateral-triangle towers
	Onto face	Onto corner	
≤ 0.1	3.5	3.9	3.1
0.2	2.8	3.2	2.7
0.3	2.5	2.9	2.3
0.4	2.1	2.6	2.1
≥ 0.5	1.8	2.3	1.9

TABLE E6(B)
DRAG FORCE COEFFICIENTS (C_d) FOR LATTICE TOWERS—
SQUARE PLAN WITH CIRCULAR MEMBERS

Solidity of front face (δ)	Parts of tower in sub-critical flow $b_i V_{des,\theta} < 3 \text{ m}^2/\text{s}$		Parts of tower in super-critical flow $b_i V_{des,\theta} \geq 6 \text{ m}^2/\text{s}$	
	Onto face	Onto corner	Onto face	Onto corner
≤ 0.05	2.2	2.5	1.4	1.2
0.1	2.0	2.3	1.4	1.3
0.2	1.8	2.1	1.4	1.6
0.3	1.6	1.9	1.4	1.6
0.4	1.5	1.9	1.4	1.6
≥ 0.5	1.4	1.9	1.4	1.6

TABLE E6(C)
DRAG FORCE COEFFICIENTS (C_d) FOR LATTICE TOWERS—
EQUILATERAL TRIANGLE PLAN WITH CIRCULAR MEMBERS

Solidity of front face (δ)	Parts of tower in sub-critical flow $b_i V_{des,\theta} < 3 \text{ m}^2/\text{s}$ (all wind directions)	Parts of tower in super-critical flow $b_i V_{des,\theta} \geq 6 \text{ m}^2/\text{s}$ (all wind directions)
	≤ 0.05	1.8
0.1	1.7	1.1
0.2	1.6	1.1
0.3	1.5	1.1
0.4	1.5	1.1
≥ 0.5	1.4	1.2

NOTES TO TABLES E6(A) to E6(C):

- 1 A_z = area of members in one face projected horizontally normal to the face (this area does not change with wind direction). This is the reference area for the drag coefficients in Tables E6(A), E6(B) and E6(C) in the application of Equation 2.5(3).
- 2 δ = solidity ratio of the structure (surface or open frame), that is the ratio of the area A_z as defined in Note 1, to the total projected area enclosed over the section height by the boundaries of the frame. For intermediate values of solidity, linear interpolation shall be used.
- 3 b_i = average diameter or breadth of a section of a tower member.
- 4 In Tables E6(B) and E6(C), linear interpolation shall be used for values of $b_i V_{des,\theta}$ between 3 and 6.

TABLE E7
DRAG FORCE COEFFICIENT (C_d) FOR UHF-ANTENNA SECTIONS
(see Figure E3)

Antenna type	Wind direction (θ) degrees	Drag force coefficient (C_d)
1 (4 sided)	0, 45	1.4
2 (5 sided)	0	1.5
2 (3 sided)	36	1.3

Licensed to Mr timothy Messer on 3 November 2009. Personal use licence only. Storage, distribution or use on network prohibited.

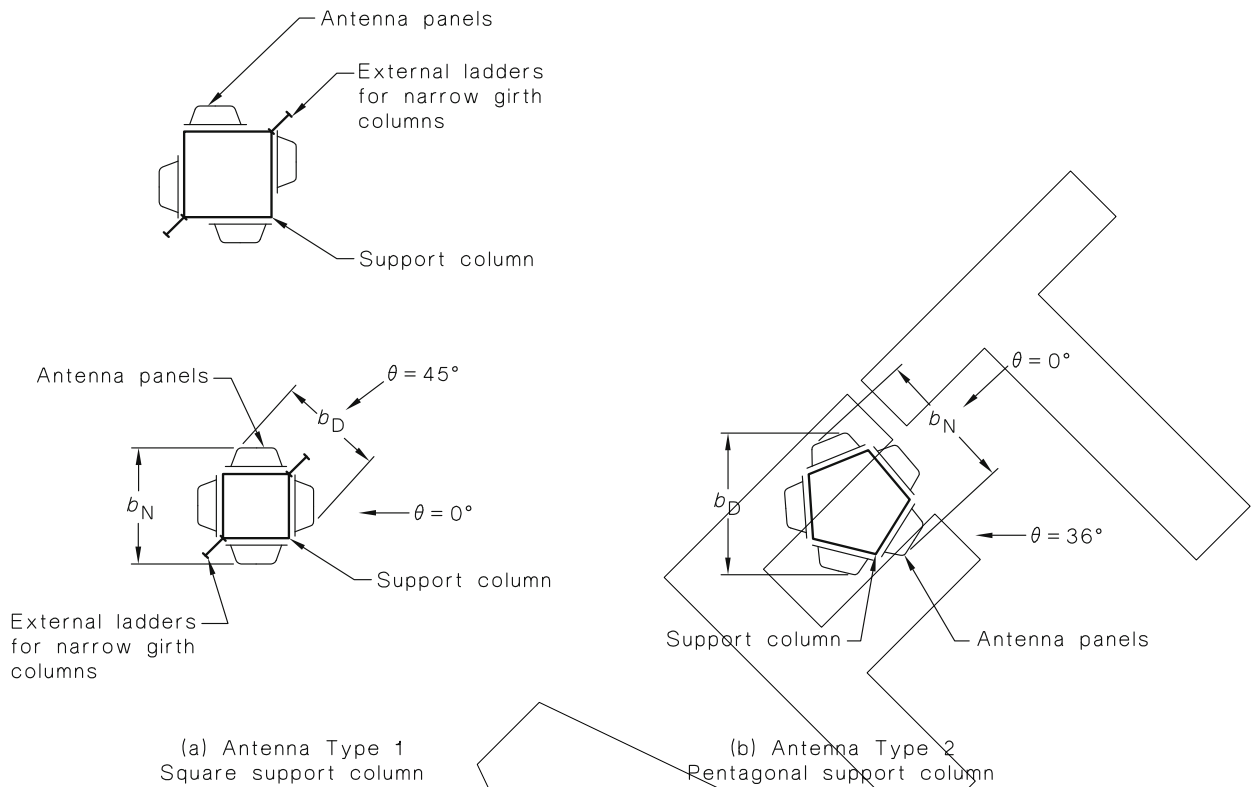

NOTES:

- 1 To calculate the area (A_z) in Equation 2.5(3), breadth (b_D) or (b_N), shall be used, as appropriate to the wind direction.
- 2 Reduction for aspect ratio may be carried out by multiplying by the correction factor (K_{ar}) given in Table E1, taking l as equal to two times the height of the end-mounted antennas.

FIGURE E3 DRAG FORCE COEFFICIENTS (C_d) FOR SECTION OF UHF ANTENNAS

E4.2.2 Tower sections with ancillaries

The effective drag force coefficient (C_{de}) for a tower section with ancillaries shall be calculated as follows:

- (a) Where ancillaries are attached symmetrically to all faces, their projected area shall be added to the projected area of the tower members (A_z).
- (b) Where ancillaries are not symmetrically placed, the total effective drag force coefficient (C_{de}) for a tower section shall be taken as follows:

$$C_{de} = C_d + \sum \Delta C_d \quad \dots E4(1)$$

where

$$\begin{aligned} \Delta C_d &= \text{additional drag coefficient due to an ancillary attached to one face or located inside the tower section:} \\ &= C_{da} K_{ar} K_{in} (A_a/A_z) \quad \dots E4(2) \end{aligned}$$

where

C_{da} = value of drag force coefficient (C_d) on an isolated ancillary on a tower, as given in Tables E3 and E4 and Figure E2

K_{ar} = aspect ratio correction factor for individual member forces
 = as given in Table E1, for linear ancillaries with aspect ratios less than 40
 = 1.0, for all other cases

K_{in} = correction factor for interference, as given in Paragraph E4.2.3

A_a = reference area of ancillaries on a tower
 = lb

where

l = the length of the linear ancillary and b is defined in Figure E4 and Tables E3 and E4

$A_{z,s}$ = total projected area of the tower section at height z

E4.2.3 Correction factor for interference

The correction factor for interference (K_{in}) shall be calculated as follows:

(a) For ancillaries attached to the face of the tower:

(i) To the face of a square tower [see Figure E4(a)]:

$$K_{in} = [1.5 + 0.5 \cos 2(\theta_a - 90^\circ)] \exp [-1.2(C_d \delta)^2] \dots E4(3)$$

(ii) To the face of a triangular tower [see Figure E4(b)]:

$$K_{in} = [1.5 + 0.5 \cos 2(\theta_a - 90^\circ)] \exp [-1.8(C_d \delta)^2] \dots E4(4)$$

(b) For lattice-like ancillaries inside the tower, K_{in} shall be taken either as 1.0 or shall be determined as follows:

(i) Inside a square tower [see Figure E4(c)]:

$$K_{in} = \exp [-1.4 (C_d \delta)^{1.5}] \dots E4(5)$$

(ii) Inside a triangular tower [see Figure E4(d)]:

$$K_{in} = \exp [-1.8(C_d \delta)^{1.5}] \dots E4(6)$$

(c) For cylindrical ancillaries inside the tower, K_{in} shall be taken either as 1.0 or shall be determined as follows:

(i) Inside a square tower [see Figure E4(e)]:

$$K_{in} = \exp [-a(C_d \delta)^{1.5}] \dots E4(7)$$

$$a = 2.7 - 1.3 \exp [-3(b/w)^2] \dots E4(8)$$

(ii) Inside a triangular tower [see Figure E4(f)]:

$$K_{in} = \exp [-c(C_d \delta)^{1.5}] \dots E4(9)$$

$$c = 6.8 - 5 \exp [-40(b/w)^3] \dots E4(10)$$

where

θ_a = angle of deviation of the wind stream from the line joining the centre of the tower cross-section to the centre of the ancillary, in degrees

δ = solidity ratio of the structure, as given in Paragraph E4.2.1

a, c = constants for ease of calculation

b/w = ratio of the average diameter of an ancillary to the average width of a structure

Licensed to Mr Timothy Messer on 3 November 2009. Personal use licence only. Storage, distribution or use on network prohibited.

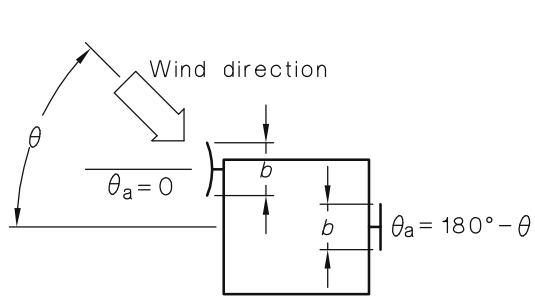

(a) Ancillary attached to face of square tower

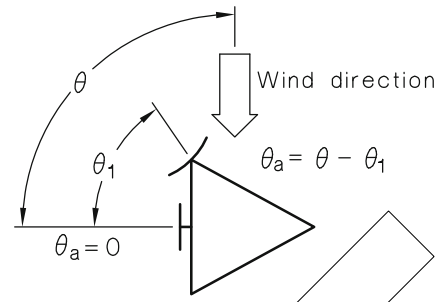

(b) Ancillary attached to face of triangular tower

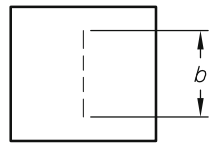

(c) Lattice-like ancillary inside square tower

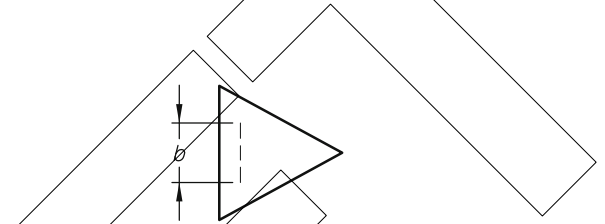

(d) Lattice-like ancillary inside triangular tower

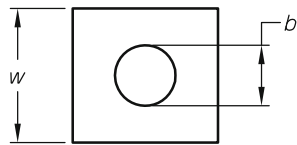

(e) Cylindrical ancillary inside square tower

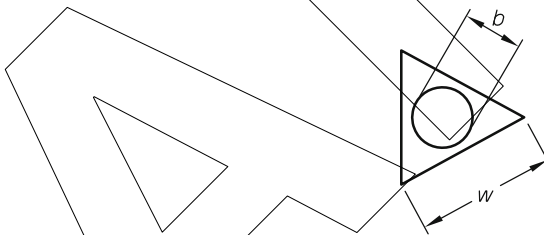

(f) Cylindrical ancillary inside triangular tower

FIGURE E4 TOWER SECTIONS WITH ANCILLARIES

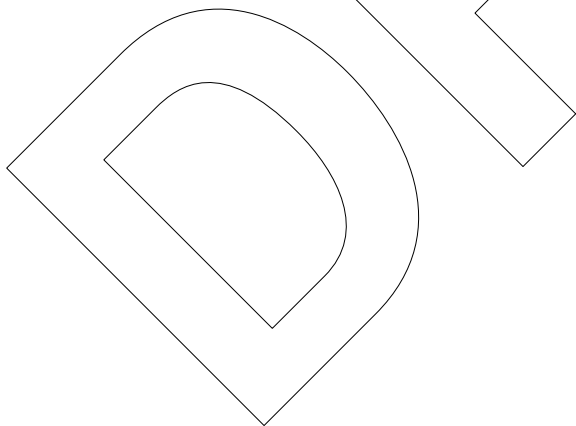

APPENDIX F
 FLAGS AND CIRCULAR SHAPES
 (Normative)

F1 GENERAL

This Appendix shall be used to calculate aerodynamic shape factors (C_{fig}) for drag forces on flags, discs and spherical shapes.

All pressure coefficients shall be used with the value of wind speed applying at the midheight of the component being considered.

F2 FLAGS

The aerodynamic shape factor (C_{fig}) for flags is as follows:

- (a) *Fixed flag*, shall be treated as elevated hoarding (see Appendix D).
- (b) *Free flag (including dynamic effects from flutter)*;

$$C_{fig} = 0.05 + 0.7 \frac{m_f}{\rho_{air} c} \left(\frac{A_{ref}}{c^2} \right)^{-1.25}, \text{ but not greater than } 0.76 \quad \dots \text{ F1}$$

where

m_f = mass per unit area of flag, in kilograms per square metre

ρ_{air} = density of air which shall be taken as 1.2 kg/m^3

c = net height of flag (see Figure F1)

l_f = flag length (see Figure F1)

A_{ref} = reference area of flag, as given in Figure F1 (area of flag perpendicular to the wind direction)

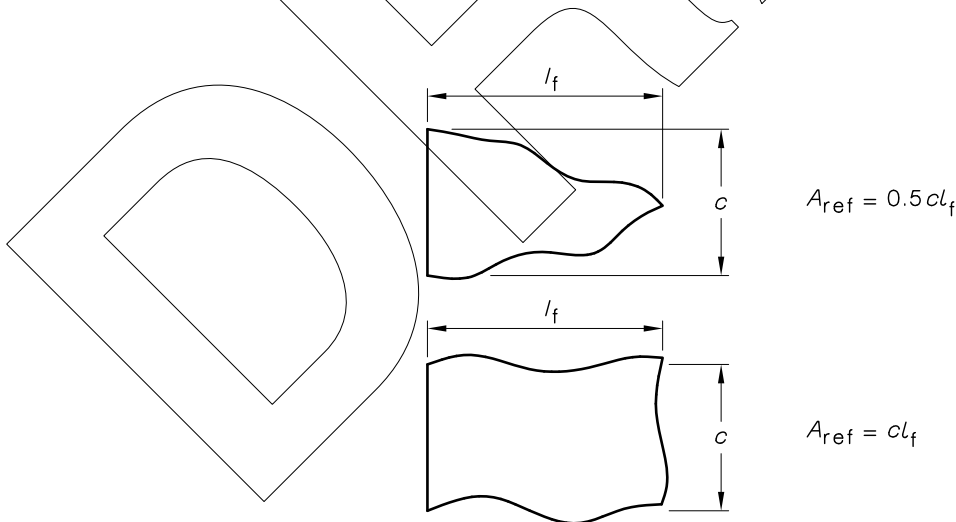
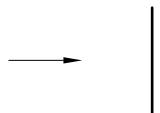
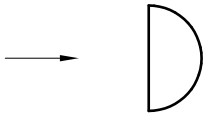
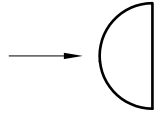
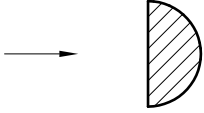
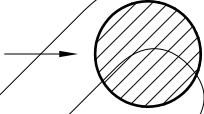

FIGURE F1 REFERENCE AREA FOR FLAGS

F3 CIRCULAR SHAPES

The aerodynamic shape factor (C_{fig}) for calculating drag forces on circular shapes shall be as given in Table F1.

**TABLE F1
AERODYNAMIC SHAPE FACTOR FOR CIRCULAR SHAPES**

Cross-sectional shape	Description of shape	Aerodynamic shape factor (C_{fig})
	Circular disc	1.3
	Hemispherical bowl (cup to wind)	1.4
	Hemispherical bowl	0.4
	Hemispherical solid (flat to wind)	1.2
	Spherical solid	0.5 for $bV_{des,\theta} < 7$ 0.2 for $bV_{des,\theta} \geq 7$

NOTE: The reference area A_{ref} for shapes in Table F1 shall be the projected area normal to the wind direction.

Licensed to Mr timothy Messer on 3 November 2009. Personal use licence only. Storage, distribution or use on network prohibited.

APPENDIX G
ACCELERATIONS FOR WIND-SENSITIVE STRUCTURES
(Informative)

G1 ACCELERATION FOR SERVICEABILITY

To provide some indication of motion serviceability it is noted that for wind-sensitive buildings, mostly exposed to free stream flow, acceptable crosswind acceleration levels may be exceeded if—

$$h^{1.3} / m_0 > 0.0016$$

where

h = average roof height of a structure above the ground, in metres

m_0 = average mass per unit height

In conditions of high turbulence, due to interference from other buildings, a more conservative approach to the use of this indicator should be taken. Should the inequality indicate likely high acceleration levels then the designer should undertake more detailed analysis or wind tunnel model studies.

G2 PEAK ALONG-WIND ACCELERATION FOR SERVICEABILITY

The peak acceleration at the top of a structure in the along-wind direction (\ddot{y}_{max}) in metres per second squared, is as follows:

$$\begin{aligned} \ddot{x}_{max} &= m_0 h^2 \times \text{resonant component of peak base bending moment} \\ &= \frac{3}{m_0 h^2} \frac{\rho_{air} g_R I_h \sqrt{\frac{SE_t}{\zeta}}}{(1 + 2g_v I_h)} \left\{ C_{fig, windward} \sum_{z=0}^h [V_{des,\theta}(z)]^2 b_z z \Delta z - C_{fig, leeward} [V_{des,\theta}(h)]^2 \sum_{z=0}^h b_z z \Delta z \right\} \end{aligned} \quad .G2$$

where

- m_0 = average mass per unit height
- ρ_{air} = density of air which, shall be taken as 1.2 kg/m³
- $V_{des,\theta}(z)$ = building orthogonal design wind speeds as a function of height z
- $V_{des,\theta}(h)$ = building orthogonal design wind speeds evaluated at height h
- b_z = average breadth of the structure at the section at height z
- Δ_z = height of the section of the structure upon which the wind pressure acts

G3 CROSSWIND ACCELERATION FOR SERVICEABILITY OF TALL BUILDINGS AND TOWERS OF RECTANGULAR CROSS-SECTION

G3.1 General

This Paragraph gives methods for determining peak accelerations at the top of tall enclosed buildings and towers of rectangular cross-section. Calculation of crosswind response is not required for porous lattice towers.

NOTE: AS/NZS 1170.2 Supp 1, gives further guidance where calculations of crosswind response yield high values.

G3.2 Peak crosswind acceleration for serviceability

The peak acceleration in the crosswind direction (\ddot{y}_{\max}) in metres/second squared, at the top of a structure with constant mass per unit height (m_0) should be determined as follows:

$$\ddot{y}_{\max} = \frac{1.5bg_R}{m_0} \left[\frac{0.5\rho_{\text{air}} [V_{\text{des},\theta}]^2}{(1 + g_v I_h)^2} \right] K_m \sqrt{\frac{\pi C_{fs}}{\zeta}} \quad \dots \text{G3(1)}$$

where

b = breadth of a structure, normal to the wind stream

g_R = peak factor for resonant response (10 min period) given by:

$$= \sqrt{[2 \log_e (600n_c)]} \quad \dots \text{G3(2)}$$

n_c = first mode natural frequency of vibration of a structure in the crosswind direction, in hertz

m_0 = average mass per unit height

g_v = peak factor for the upwind velocity fluctuations, which may be taken as 3.7

I_h = turbulence intensity, obtained from Table 6.1 by setting $z = h$

K_m = mode shape correction factor for crosswind acceleration, given by:

$$= 0.76 + 0.24k$$

where

k = mode shape power exponent for the fundamental mode and values of the exponent k should be taken as:

= 1.5 for a uniform cantilever

= 0.5 for a slender framed structure (moment resisting)

= 1.0 for a building with central core and moment resisting façade

= 2.3. for a tower decreasing in stiffness with height, or with a large mass at the top

= the value obtained from fitting $\phi_1(z) = (z/h)^k$ to the computed modal shape of the structure

$\phi_1(z)$ = first mode shape as a function of height z , normalized to unity at $z = h$

C_{fs} = crosswind force spectrum coefficient generalized for a linear mode shape given in Clause 6.3.2.3

ζ = ratio of structural damping to critical damping of a structure (see Table 6.2)

*** END OF DRAFT ***

Licensed to Mr timothy Messer on 3 November 2009. Personal use licence only. Storage, distribution or use on network prohibited.

PREPARATION OF JOINT AUSTRALIAN/NEW ZEALAND STANDARDS

Joint Australian/New Zealand Standards are prepared by a consensus process involving representatives nominated by organizations in both countries drawn from all major interests associated with the subject. Australian/New Zealand Standards may be derived from existing industry Standards, from established international Standards and practices or may be developed within a Standards Australia, Standards New Zealand or joint technical committee.

During the development process, Australian/New Zealand Standards are made available in draft form at all sales offices and through affiliated overseas bodies in order that all interests concerned with the application of a proposed Standard are given the opportunity to submit views on the requirements to be included.

The following interests are represented on the committee responsible for this draft Australian/ New Zealand Standard:

Association of Consulting Engineers Australia
Australian Building Codes Board
Australian Steel Institute
Australasian Wind Engineering Society
Building Research Association of New Zealand
Cement and Concrete Association of Australia
Cyclone Testing Station—James Cook University
Energy Network Association
Housing Industry Association
Engineers Australia
Institution of Professional Engineers New Zealand
Master Builders Australia
New Zealand Heavy Engineering Research Association
Steel Reinforcement Institute of Australia
University of Canterbury New Zealand
University of Melbourne
University of Newcastle

Additional interests participating in preparation of Standard:

Australian Window Association
Bureau of Meteorology
Geoscience Australia
GNS Science, New Zealand
Monash University
National Institute of Water and Atmospheric Research Ltd, NZ
Timber Development Association
University of Auckland, New Zealand
University of Tasmania
University of Western Sydney

Standards Australia

Standards Australia is an independent company, limited by guarantee, which prepares and publishes most of the voluntary technical and commercial standards used in Australia. These standards are developed through an open process of consultation and consensus, in which all interested parties are invited to participate. Through a Memorandum of Understanding with the Commonwealth government, Standards Australia is recognized as Australia's peak national standards body.

Standards New Zealand

The first national Standards organization was created in New Zealand in 1932. The Standards Council of New Zealand is the national authority responsible for the production of Standards. Standards New Zealand is the trading arm of the Standards Council established under the Standards Act 1988.

Australian/New Zealand Standards

Under a Memorandum of Understanding between Standards Australia and Standards New Zealand, Australian/New Zealand Standards are prepared by committees of experts from industry, governments, consumers and other sectors. The requirements or recommendations contained in published Standards are a consensus of the views of representative interests and also take account of comments received from other sources. They reflect the latest scientific and industry experience. Australian/New Zealand Standards are kept under continuous review after publication and are updated regularly to take account of changing technology.

International Involvement

Standards Australia and Standards New Zealand are responsible for ensuring that the Australian and New Zealand viewpoints are considered in the formulation of international Standards and that the latest international experience is incorporated in national and Joint Standards. This role is vital in assisting local industry to compete in international markets. Both organizations are the national members of ISO (the International Organization for Standardization) and IEC (the International Electrotechnical Commission).

Visit our web sites

www.standards.org.au

www.standards.co.nz

www.standards.com.au