

MITSUBISHI

AC SPINDLE DRIVE

FREQROL-SF

MAINTENANCE MANUAL

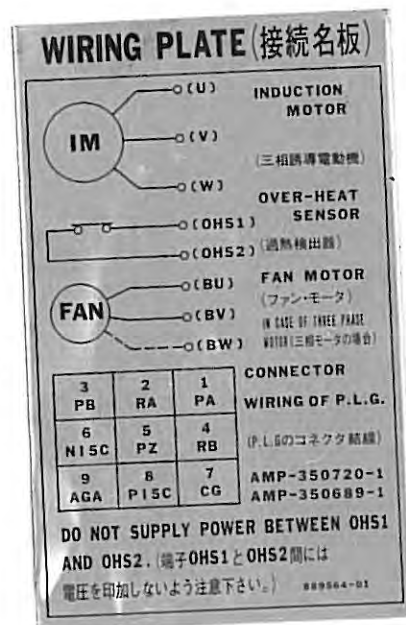

- C O N T E N T S -

1. GENERAL	1
1.1 Usage of Maintenance Manual	1
1.2 Safety during maintenance and troubleshooting	1
1.3 Storage	2
2. SPECIFICATIONS	3
2.1 AC spindle motor controller specifications	3
2.2 Output characteristics	9
2.3 Auxiliary functions	10
2.4 Composition	14
2.5 External wiring	18
2.6 Parts arrangement	24
3. ADJUSTMENT DURING OPERATION	26
3.1 Preliminary check	26
3.2 Power feeding	27
3.3 Status display and parameter setting	29
3.4 NC display	37
3.5 Parameter setting	40
3.6 Adjustment	69
3.7 Trial operation	70
3.8 Initial adjustment	71
4. CARD CHECK	76
4.1 Card SF-CA	76
4.2 Card SF-OR	85
4.3 Card SF-TL	88
4.4 Card SF-PW	91
5. ADDITION AND REPLACEMENT OF COMPONENTS	93
5.1 Addition of option card (SF-OR, DA, TL)	93
5.2 Replacement of card	94
5.3 Replacement of ROM	95
5.4 Replacement of diode module and transistor module	97
5.5 Disassembly and assembly of SJ type AC spindle motor	98

6. INSTALLATION OF ORIENTED SPINDLE STOP POSITION DETECTOR 106
6.1 Magnesensor 1-point oriented spindle stop 106
6.2 Encoder type oriented spindle stop (4096 points) 119
7. PROFILING CONTROL (C-AXIS CONTROL) ENCODER 124
7.1 Name 124
8. TROUBLESHOOTING 129
8.1 General information 129
8.2 First step of troubleshooting 130
8.3 Second step of troubleshooting 131
8.4 Detailed troubleshooting 135
9. PERIODIC INSPECTION 151
9.1 Inspection of control equipment 151
9.2 Inspection of motor 152
10. PARTS LIST 154

§1. GENERAL

1.1 Usage of Maintenance Manual

FR-SF series inverters are designed to drive machine tool spindles, and feature quiet operation, stable and rapid response, and energy saving.

This Manual mainly describes troubleshooting and maintenance of FR-SF series inverters.

1.2 Safety during maintenance and troubleshooting

The maintenance and troubleshooting should be done with the following safety consideration:

- o The control equipment should be started, maintained and remedied by qualified electrician.
- o When person who maintains or remedies the control equipment must touch a part of the equipment, he should take off finger ring, wristwatch, necktie pin, and other metallic goods before starting the work.
- o Electric shock may cause fatal accident.
When a circuit at high voltage must be checked, due care should be taken to select appropriate test/inspection equipment, tools, etc. and to use them safely (no matter whether or not the circuit is grounded).
When a test equipment is applied to a part, component, or circuit of the equipment, operator should pay attention not to touch a grounded part.
In general, test equipment should not be grounded.
During test or measurement, it is likely the high voltage is present between the test equipment and the ground.
When motor is run during adjustment or remedy, due care should be taken in this respect.
- o Person who carries out maintenance or remedy should not wear loosely. Otherwise, wear might be involved into the running machine.
- o While the control equipment is on, P.C. board or card should

not be loaded or unloaded.

- o Immediately after the control equipment is turned off, the maintenance or remedy should not be started immediately, but it should be verified that power indicator lamp LED10 (card SF-CA) is not on, before start the work (about 3 minutes is taken until the lamp goes out).

1.3 Storage

When the equipment is not used, store it in clean and dry environment.

Note that humidity and dust entering into the equipment may adversely affect insulation resistance of the equipment.

When the equipment is left out of operation for any length of time, the same cautions should be taken.

It is recommended to use a heater to keep the environment dry.

§2. SPECIFICATIONS

2.1 AC spindle motor controller specifications

Item	Series	Base speed 1500RPM series										Base speed 1150RPM series																			
		SJ-										SJ-																			
Model		5.5A	7.5A	11AP	11A	15A	18.5A	22AP	22A	26A	30A	30B	37B	45B	5.5A	7.5A	11AP	11A	15A	18.5A	22AP	22A	26A	30A	30B	37B	45B				
Continuous rating (HP)/(KW)		5/3.7	7/5.5	9/7	10/7.5	15/11	20/15	25/18.5	30/22	35/26	40/30	40/30	50/37	50/37	5/3.7	7/5.5	9/7	10/7.5	15/11	20/15	25/18.5	30/22	35/26	40/30	40/30	50/37	50/37				
30-min. rating 50% ED rating(HP)/(KW)		7/5.5	10/7.5	15/11	15/11	20/15	25/18.5	30/22	30/22	35/26	40/30	40/30	50/37	60/45	7/5.5	10/7.5	15/11	15/11	20/15	25/18.5	30/22	30/22	35/26	40/30	40/30	50/37	60/45				
Basic speed (RPM)		1500										1150																			
Max. speed (RPM)		800					600					4500					3450														
Frame No.		A112	B112		B132		C132		A160	B160	B180			A200	A112	B112		B132		C132		A160	B160	B180			A200				
Cont. rated torque (kg-m ²)		2.4	3.57	4.54	4.887	7.15	9.74	9.74	12.0	14.3	18.6	25.4	31.3	2.4	3.57	4.54	4.887	7.15	9.74	9.74	12.0	14.3	18.6	25.4	31.3						
CD ²		0.08	0.10	0.12	0.17	0.21	0.27	0.32	0.55	0.69	1.26	1.36	2.19	0.08	0.10	0.12	0.17	0.21	0.27	0.32	0.55	0.69	1.26	1.36	2.19						
Weight (kg)		60	70	75	100	100	130	150	175	200	300	300	390	60	70	75	100	100	130	150	175	200	300	300	390						
Permissible radial load (kg)		150	200											150	200																
Cooling fan (W)		35										400																			
Vibration		V5										V10																			
Sound level (dB A)		75										80																			
Direction of installation		Horizontal, or vertical with output shaft down																													
Overload margin		120% of 30-min. rated output for 1 min.																													
Ambient temperature(°C)		0 to 40																													
Insulation class		Class "F"																													
Paint color		Munsell 5.27G 2.46/0.21																													
Accessories		Pulse generator, overheat detector																													
Lubrication of bearings		Grease																													
Output characteristics		Fig. 1										Fig. 2										Fig. 3						Fig. 4			

AC spindle motor

Item		Series									
		FR-SF-2-									
Panel inside mount type	5.5K	7.5K	11K	15K	18.5K	22K	26K	30K	37K	45K	
	5.5K-C	7.5K-C	11K-C	15K-C	18.5K-C	22K-C	26K-C	30K-C	37K-C	45K-C	
Intermediate panel mount type	9	12	17	23	28	33	37	44	54	63	
Power capacity (kVA)	340	400	490	590	700	810	1000				1500
Total heat generated(*1) (W)	200/200 ~ 230V+10%, -15%, 50/60Hz±3Hz										
Power supply (*2)	200/200 ~ 230V+10%, -15%, 50/60Hz±3Hz										
Panel inside mount type	24	27	27	37	48	67	73	90			
	24	27	27	37	48	67	73	90			
Intermediate panel mount type											
Main circuit	Transistor sinusoidal wave PWM inverter										
Control circuit	Pulse generator speed feedback, digital closed loop control, vector control										
Brake	Regenerative brake										
Speed control range(rpm)	35 - 8000	35 - 6000	35 - 4500	35 - 3450							
Speed regulation	Less than 0.2% of maximum speed (load variable within range from 10% to 100%)										
Speed reference signal	Analog signal, +10V Max. (input impedance: About 10 Kohm)										
Ambient temp./humidity	-5 to 55°C, 45 to 85%RH										
Atmosphere	To be free from detrimental gas and dust (Environmental requirement: JEM 1103, Grade C)										
Vibration	Less than 0.5G										
Applicable standard	IEC										

Controller

- Notes: 1. This is the total heat generated during operation with the continuous rated output. In the case of intermediate panel mount type, panel outside heat is equal to [(total heat - 120) x 0.7 (W)].
2. When supply voltage other than specified here is used, use a transformer.
3. For constant-output range other than "1:8" and "1:12", consult us.

Item	Series	Wide range (1:8) constant output series (Note 3)									
Model		SJ-									
Continuous ranging (HP)/(KW)		5.5XWB	7.5XWB	11XWB	15XWB	18.5XWB	22XWB	5.5XWC	7.5XWC	11XWC	15XWC
30-min. rating 50% ED rating (HP)/(KW)		5/3.7	7/5.5	10/7.5	15/11	20/15	25/18.5	5/3.7	7/5.5	10/7.5	15/11
Basic speed (RPM)		750		625		500		400		400	
Max. speed (RPM)		6000		5000		4000		6000		4800	
Frame No.		B112	B132	C132	B180	B180	A200	B132	A180	B180	A200
Cont. rated torque (kg-m)		4.80	7.14	9.74	17.1	23.3	36.0	7.20	13.4	18.3	26.8
CD ² (kg-m ²)		0.12	0.21	0.32	0.69	1.36	2.19	0.21	0.55	1.26	2.19
Weight (kg)		75	110	150	200	300	390	110	175	300	390
Permissible radial load (kg)		200	300		400	600	600	300		400	600
Cooling fan (w)		35		130		3φ 60		35	180	3φ 60	
Vibration		V5		V10		V5		V10		V10	
Sound level (dB A)		75		80		85		75	80	85	
Direction of installa- tion		Horizontal, or vertical with output shaft down									
Overload margin		120% of 30-min rated output for 1 min.									
Ambient temperature(°C)		0 - 40									
Insulation class		Class "F"									
Paint color		Munsell 5.27G 2.46/0.21									
Accessories		Pulse generator, overheat detector									
Lubrication of bearings		Grease									
Output characteristic		Fig. 5		Fig. 6		Fig. 7		Fig. 8		Fig. 9	

Item		Series										
		FR-SF-2-										
Panel inside mount type	11K	11K	22K	26K	30K	37K	11K	15K	26K	30K		
	11K-C	11K-C	22K-C	26K-C	30K-C	37K-C	11K-C	15K-C	26K-C	30K-C		
Intermediate panel mount type	9	12	17	23	38	33	9	12	17	23		
Power capacity (KVA)	340	400	490	590	700	810	340	400	490	590		
Total heat generated(*1) (W)	200/220 ~ 230V+10%, -15%, 50/60Hz±3Hz											
Power supply (*2)	200/220 ~ 230V+10%, -15%, 50/60Hz±3Hz											
Panel inside mount type	27	48	67	73	27	37	48	67				
	27	48	67	73	27	37	48	67				
Intermediate panel mount type	Transistor sinusoidal wave PWM inverter											
Main circuit	Pulse generator speed feedback, digital closed loop control, vector control											
Control circuit	Regenerative brake											
Brake	35 - 6000											
Speed control range	35 - 5000											
Speed regulation	35 - 4000											
Speed reference signal	35 - 6000											
Ambient temp./humidity	Less than 0.2% of maximum speed (load variable within range of 10% to 100%)											
Atmosphere	Analog signal, +10V Max. (input impedance: About 10Kohm)											
Vibration	-5°C to 55°C, 45% to 85%RH											
Applicable standard	To be free from detrimental gas and dust (Environmental requirement: JEM 1103, Grade C)											
	Less than 0.5G											
	IEC											

- Notes: 1. This is the total heat generated during operation with the continuous rated output. In the case of intermediate panel mount type, panel outside heat is equal to [(total heat - 120) x 0.7 (W)].
2. When supply voltage other than specified here is used, use a transformer.
3. For constant-output range other than "1:8" and "1:12", consult us.

Item	Series	High-speed series				
Model	5.5AZ	7.5AZ	SJ-5.5LH	7.5LH	11LH	15LH
Continuous rating (HP)/(KW)	5/3.7	7/5.5	5/3.7	7/5.5	10/7.5	15/11
30-min. rating						
50% ED rating(HP)/(KW)	7/5.5	10/7.5	7/5.5	10/7.5	15/11	20/11
Basic speed (RPM)	1500		5000			5000
Max. speed (RPM)	10000		20000			15000
Frame No.	A112	B112	A100	B100	B132	C132
Cont. rated torque (kg-m)	2.4	3.57	0.72	1.07	1.46	2.14
GD ² (kg-m ²)	0.08	0.10	0.02	0.025	0.07	0.095
Weight (kg)	60	70	60	65	95	115
Permis. radial load (kg)	140					
Cooling fan (W)			35			
Vibration			V5			
Sound level (dB A)	75			85		
Direction of installation	Horizontal, or vertical with output shaft down					
Overload margin	120% of 30-min. rated output for 1 min.					
Ambient temperature(°C)	0 to 40					
Insulation class	Class "F"					
Paint color	Munsell 5.27G 2.46/0.21					
Accessories	Pulse generator, overheat detector					
Lubrication of bearings	Grease					
Output characteristic	Fig. 10		Fig. 11		Fig. 12	

AC Spindle Motor

Item		Series				FR-SF-2-			
Panel inside mount type	Intermediate panel mount type	5.5K-H	7.5K-H	7.5K-H	11K-H	15K-H			
		5.5K-HC	7.5K-HC	7.5K-HC	11K-HC	15K-HC			
Power capacity (kVA)		9	12	9	12	17			
Total heat generated(*1) (W)		340	400	340	400	490			590
Power supply (*2)		200/200 ~ 230V+10%, -10%, 50/60Hz±3Hz							
Panel inside mount type	Intermediate panel mount type	24			27				37
		24			27				37
Main circuit									
Transistor sinusoidal wave PWM inverter									
Control circuit									
Pulse generator speed feedback, digital closed loop control, vector control									
Brake									
Regenerative brake									
Speed control range		35 - 10000		35 - 20000		35 - 15000			
Speed regulation		Less than 0.2% of max. speed (load variable within range from 10% to 100%)							
Speed reference signal		Analog signal, +10V Max. (input impedance: About 10 Kohm)							
Ambient temp./humidity		-5 to 55°C, 45 to 85%RH							
Atmosphere		To be free from detrimental gas and dust (Environmental requirement: JEM 1103, Grade C)							
Vibration		Less than 0.5G							
Applicable standard		IEC							

Controller

- Notes: 1. This is the total heat generated during operation with the continuous rated output. In the case of intermediate panel mount type, panel outside heat is equal to [(total heat - 120) x 0.7 (W)].
2. When supply voltage other than specified here is used, use a transformer.
3. For constant-output range other than "1:8" and "1:12", consult us.

2.2 Output characteristics

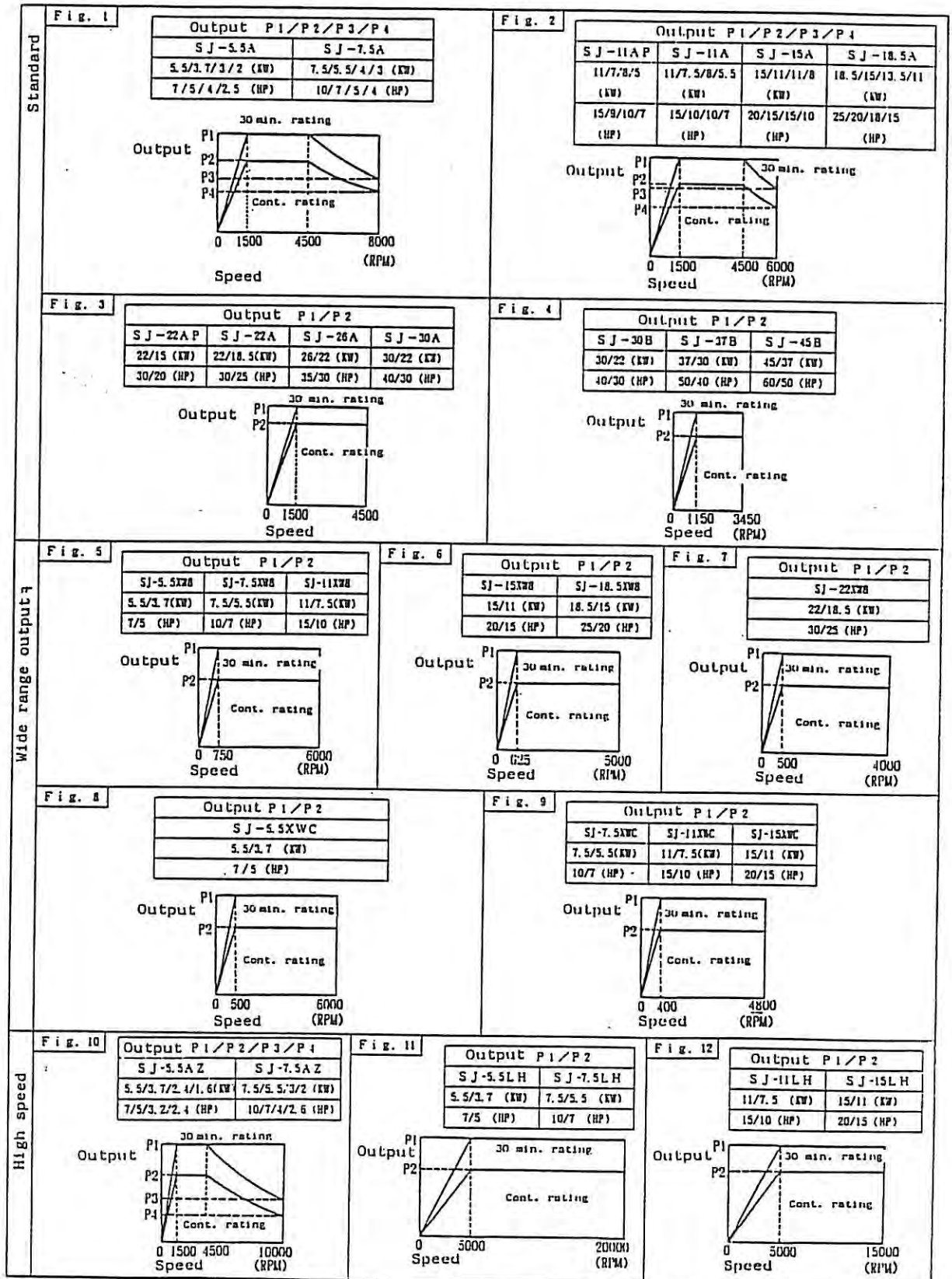

2.3 Auxiliary functions

Function	Application	Description	Refer to	Internal parameter setting range	Input/output
Speed meter output	Speed display	When speed is maximum, single-swing DC1mA meter reads the maximum value (full scale) and DC10V is output.			Max. DC10V output
Load meter output	Load display	When load is 120% of 30-min. rated output, single-swing DC1mA meter reads the maximum value (full scale) and DC3V or DC10V (selectable, standard: 10V) is output.			DC3V or DC10V output
Zero speed output signal	Machine interlock	Signal which closes contact, or turns on output transistor, when motor speed is below the referenced speed.		0 - 1000rpm Standard: 50rpm Quasi-standard: 25rpm	Contact output Open-emitter output
Up-to-speed output signal	Answer back to NC	Signal which turns on output transistor when speed is within $\pm 15\%$ of the referenced speed.			Open-emitter output Open-collector output
Speed detect output		Signal which turns on output transistor when motor speed is below the referenced speed.		1 - 120% of max. speed Standard: 10%	Open-emitter output Open-collector output
Load detect output signal	Prevention of cutter sticking	Signal which turns on output transistor when output			Open-emitter output

Function	Application	Description	Refer to	Internal parameter setting range	Input/output
		exceeds 110% of rated output.			
Spindle fault output signal (alarm)	Spindle fault	Signal which opens contact, or turns off output transistor, if spindle fault occurs			Contact output Open-emitter output
Spindle fault content output signal (alarm)	Spindle fault content	In case of spindle fault, the data indicating the cause is output (combination of 4 output transistor statuses).			Open-emitter output
Torque limit output signal		Signal which turns on output transistor while torque is being limited.			Open-emitter output
Torque limit command input	Motor torque is reduced temporarily when gear is shifted, for example	Torque limit input signal With signal input through TL1 and OT, motor torque is limited to half of parameter TLM (#35) setting. With signal input through TL2 and OT, motor torque is limited to parameter TLM (#35) setting.		0 - 120% of maximum torque Standard: 10%	External input
Machine ready input	Verification that machine is ready.	"Ready" when SET1 - SET2 is closed.			External input
Alarm reset input	Reset of alarm flag in controller	Alarm condition is reset when ARS1 - ARST2 is closed.			External input

Function	Application	Description	Refer to	Internal parameter setting range	Input/output
Speed reference digital/analog select input	Selection of digital speed reference signal	Digital signal is input when DIG - OA is closed, and analog signal is input when DIG - OA is opened.			External input
Speed override input	Override to speed in automatic operation	Override can be set within a range from 50% to 120% by external potentiometer. Override is exerted when DEF - OD is closed.			External input
Emergency stop input	Emergency stop	Motor is decelerated by regenerative brake to stop. Emergency stop signal is given when ESP1 - ESP2 is opened.			External input
Alarm signal output for emergency stop	Alarm signal is output (ON) or not output (OFF) in case of emergency stop.	When "ON" is selected, alarm signal is output in case of emergency stop. When "OFF" is selected, alarm signal is not output in case of emergency stop.		"ON"/"OFF"	Contact output Open-emitter output

Function	Application	Description	Refer to	Internal parameter setting range	Input/output
Accel./decel. time constant setting	Acceleration/deceleration time constant	True acceleration or deceleration time depends on load inertia (GD^2).		0 - 32767msec Standard: 0.3sec	Internal setting

2.4 Composition

2.4.1 Basic composition (standard) FR-SF-2-□K

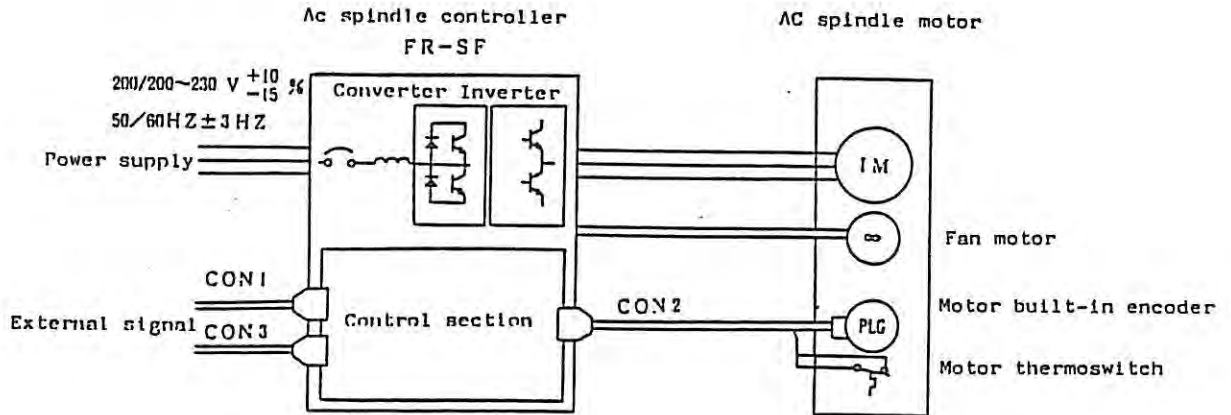

2.4.2 Equipped with oriented spindle stop function (optional card SF-OR is used) FR-SF-2-□K-R

(1) Magnesensor spindle orientation (1 div.) specification

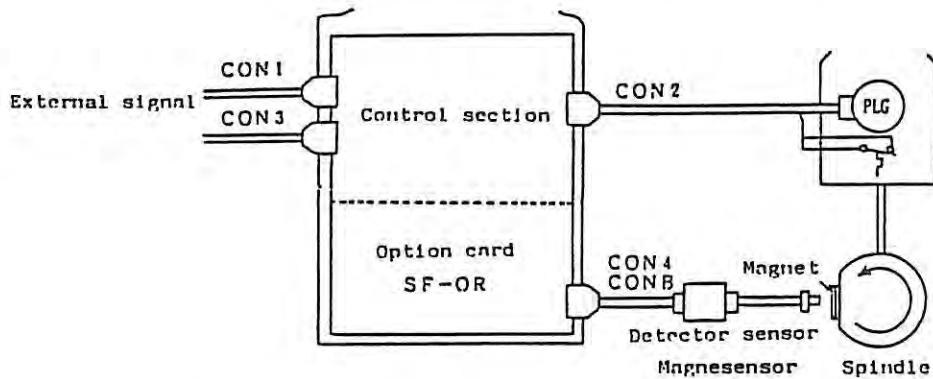

(2) Encoder spindle orientation (4096 div.) specification, equipped with index function

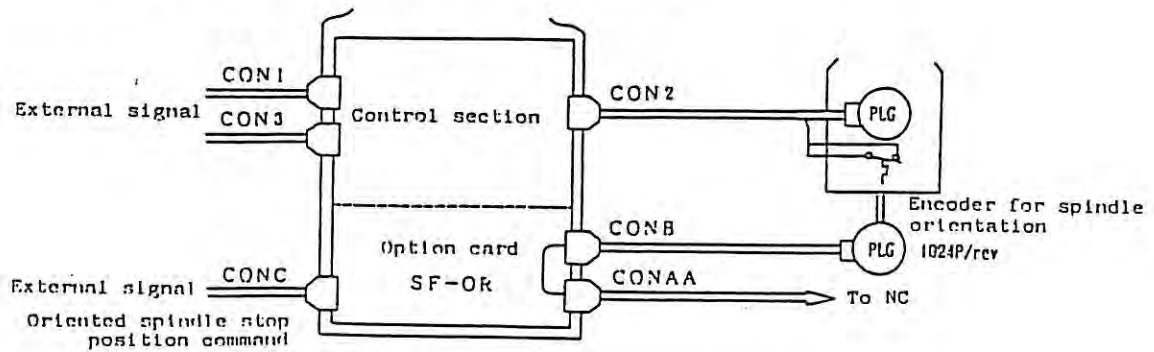

- (3) Z-phase controlled motor built-in encoder multi-point spindle orientation specification, equipped with index function

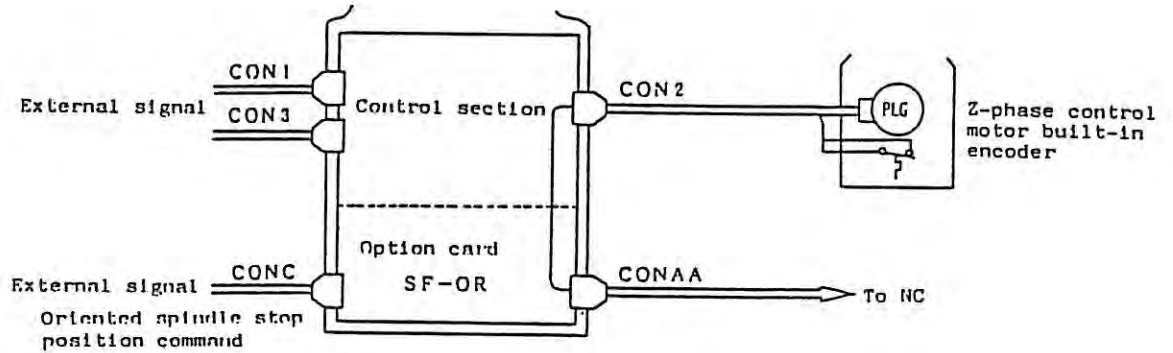

- (4) Magnesensor spindle orientation (1 div.) specification, equipped with motor speed feedback output
(for spindle speed display/sync. feed signal)

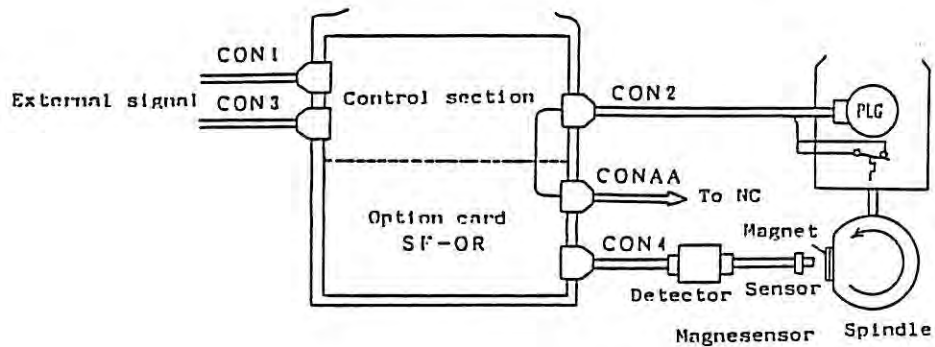

2.4.3 Controller bus-linked to M300 series CNC FR-SF-2-[]K-T
 Equipped with high-speed sync. tap/spindle orientation
 (optional card SF-TL is used)

- (1) Motor built-in encoder high-speed sync. tap/magnesensor spindle orientation (1 div.) specification

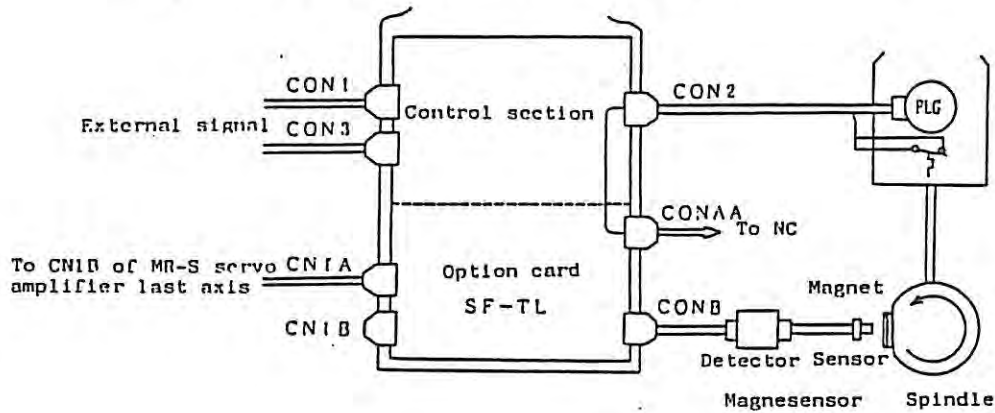

- (2) Encoder high-speed sync. tap spindle orientation (4096 div.) specification, equipped with index function

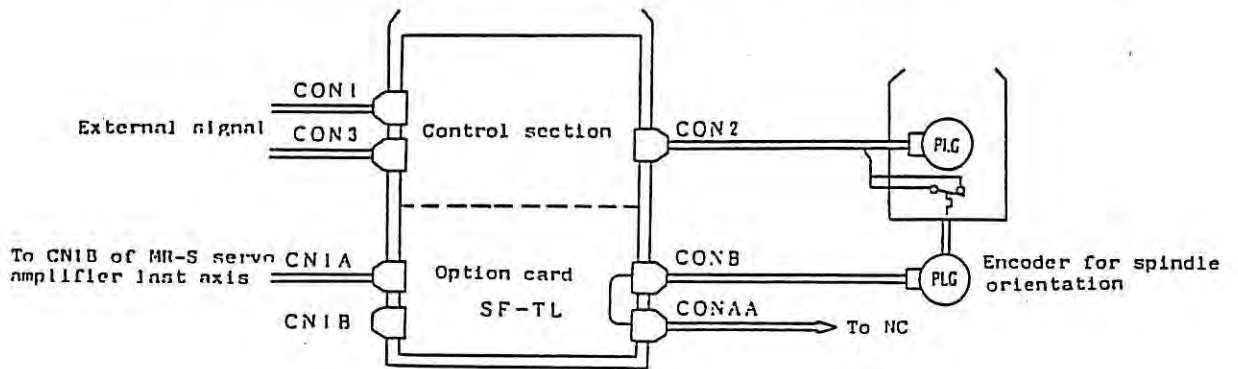

- (3) Z-phase controlled motor built-in encoder high-speed sync. tap/multi-point spindle orientation specification, equipped with index function

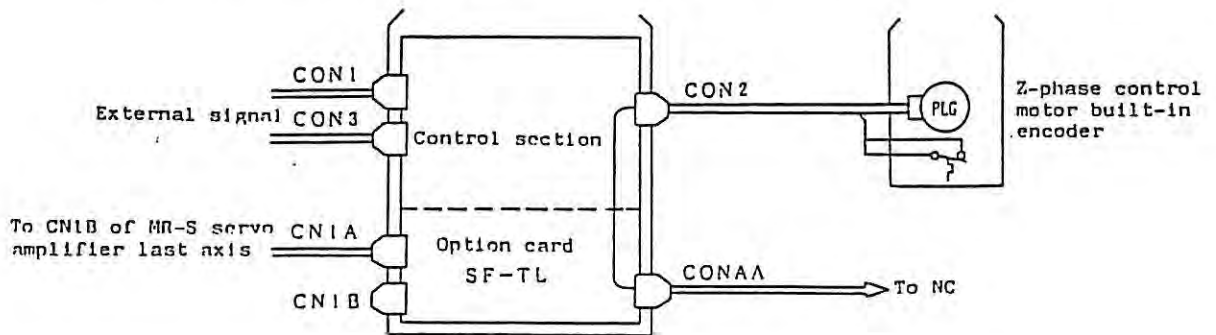

2.4.4 Controller bus-linked to M300 series CNC ... FR-SF-2-[]K-T

Option card SF-TL is used.

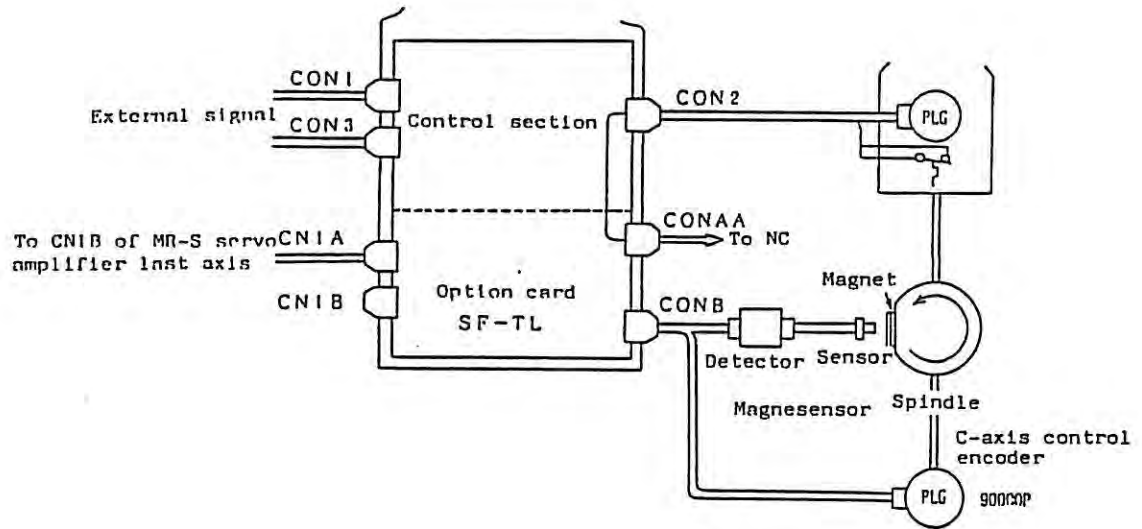

2.5 External wiring

2.5.1 Basic wiring (without option card)

FR-SF-2-□K

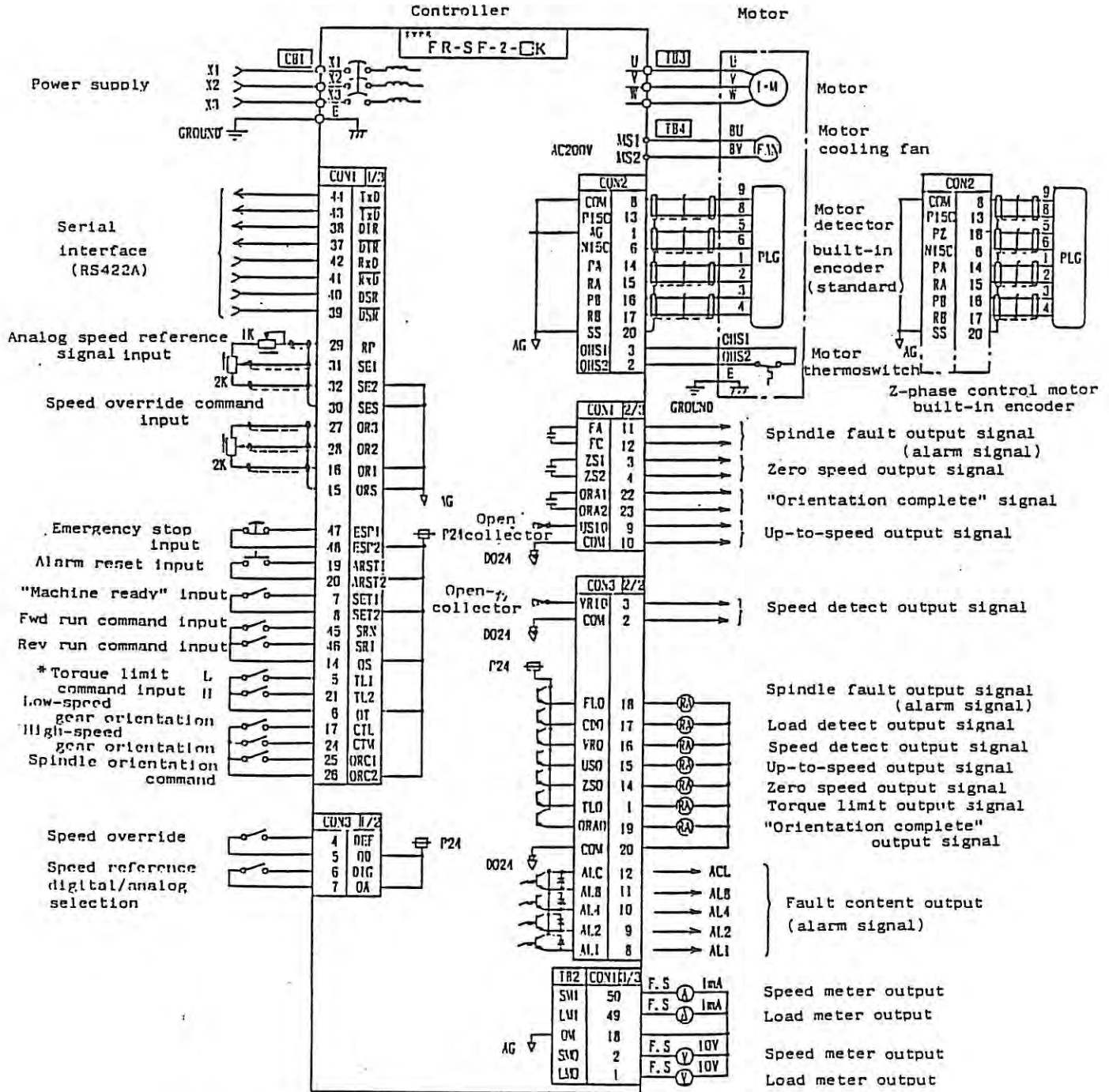

Note *: When the system is equipped with index function, input signal TL1 is used for "CW index", and TL2 for "CCW index".

2.5.2 Model equipped with oriented spindle stop function
 (with option card SF-OR) FR-SF-2-□K-R

(1) Magnesensor spindle orientation (1 div.)

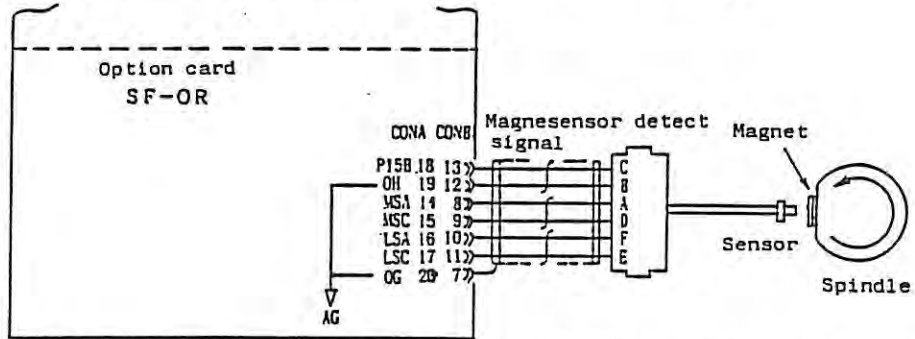

(2) Encoder spindle orientation (4096 div.)/indexing function

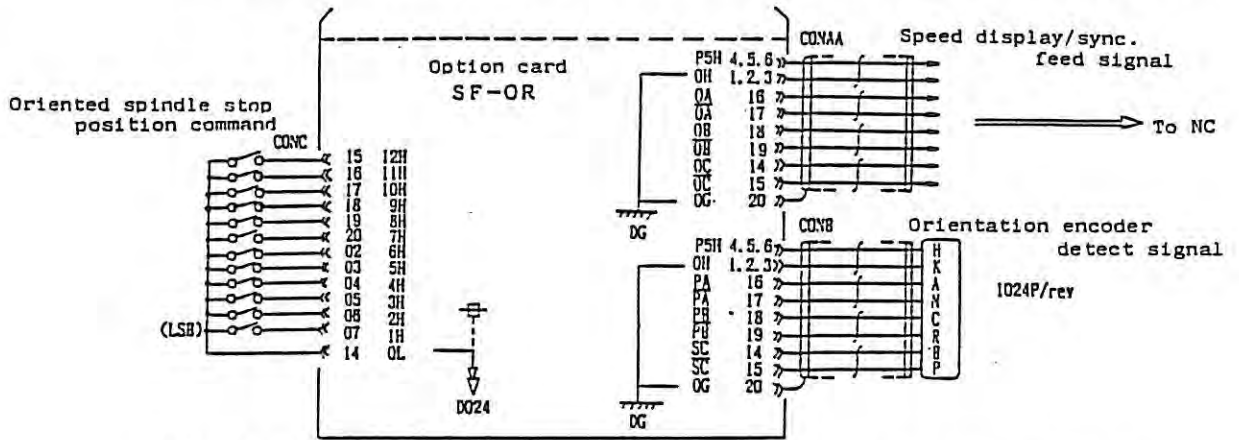

(3) Z-phase control motor built-in encoder multi-point spindle orientation/index function

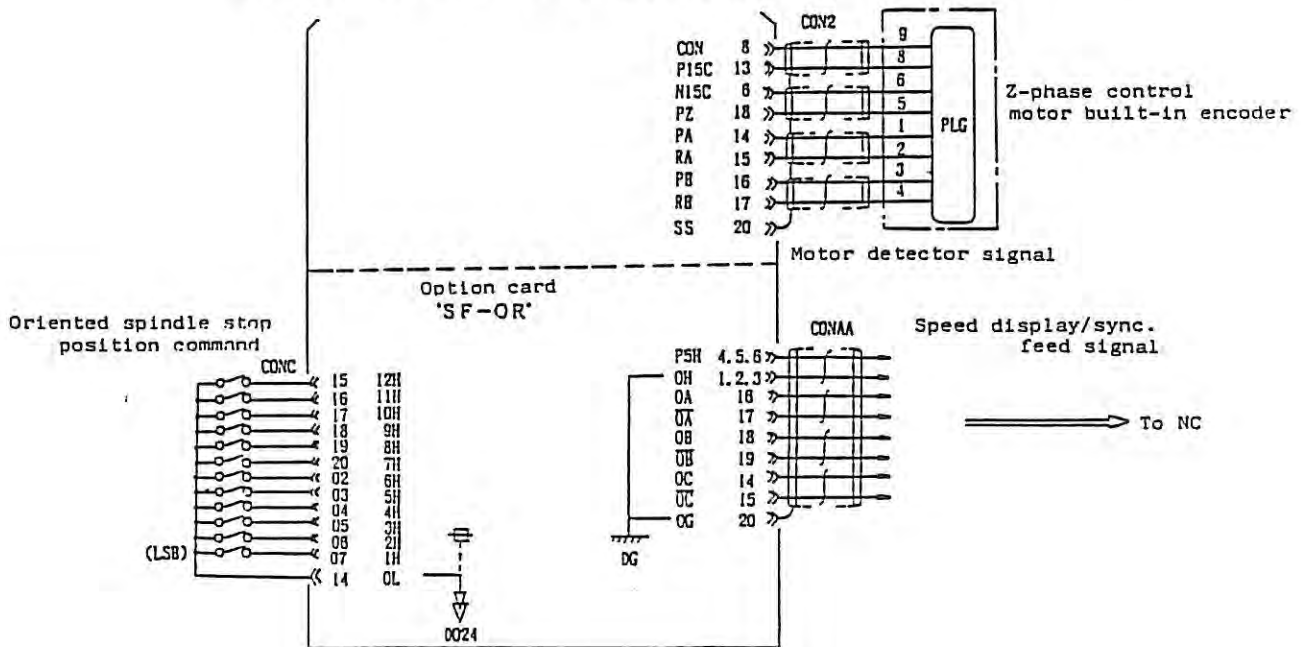

- (4) Magnesensor spindle orientation (1 div.) with motor speed feedback output (for spindle speed display, sync. feed signal)

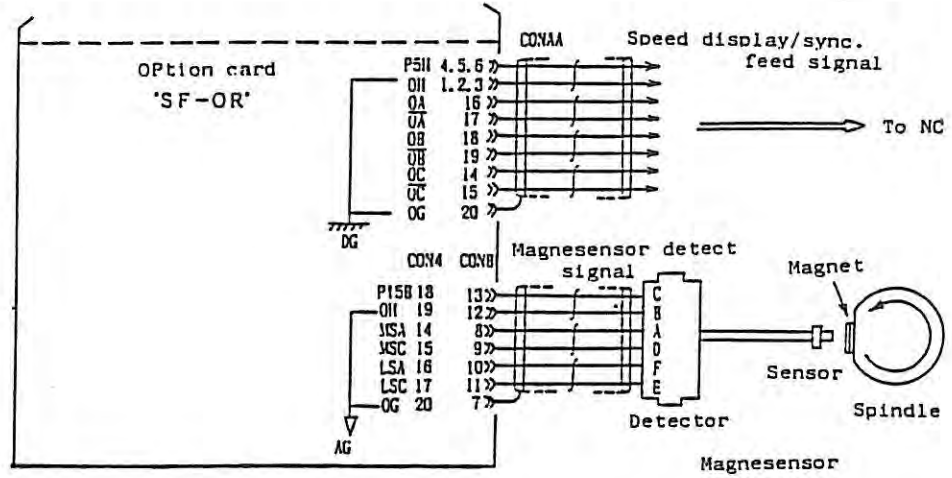

2.5.3 Model bus-linked to M300 series CNC, and equipped with high-speed sync. tap spindle orientation (with option card SF-TL) FR-SF-2-K-T

(1) Motor built-in encoder high-speed sync. tap magnesensor spindle orientation (1 div.)

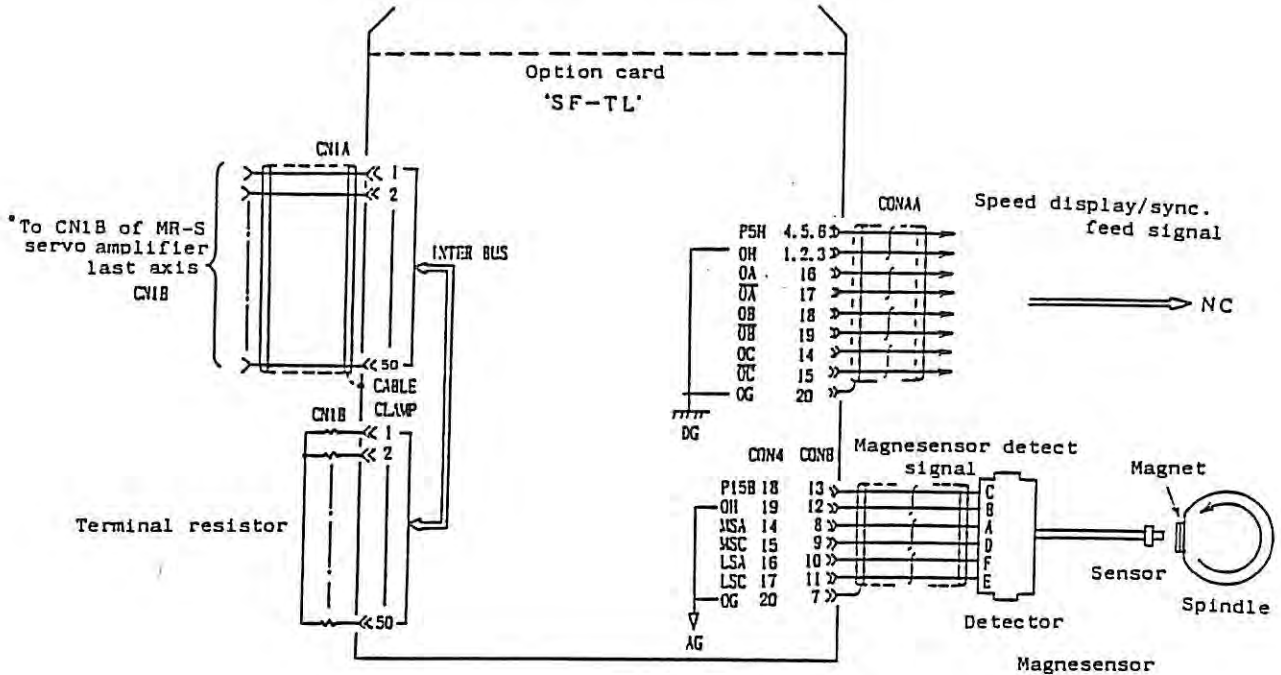

(2) Encoder high-speed sync. tap spindle orientation (4096 div.)/index function

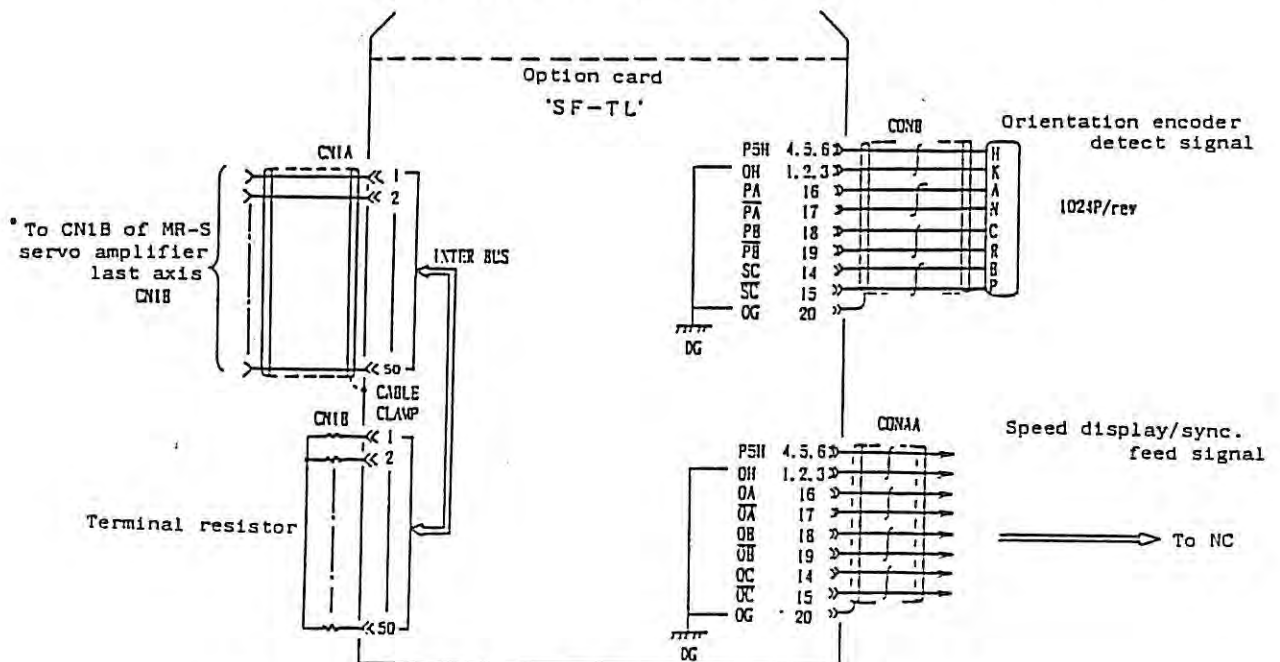

*When cable is used for bus-line connection to M300, it must be shielded with cable clamps (secured to grounding plate). For installation of the cable, refer to the Standard Specification (BNP-A0B01-18-E).

- (3) Z-phase control motor built-in encoder high-speed sync. tap multi-point spindle orientation/index function

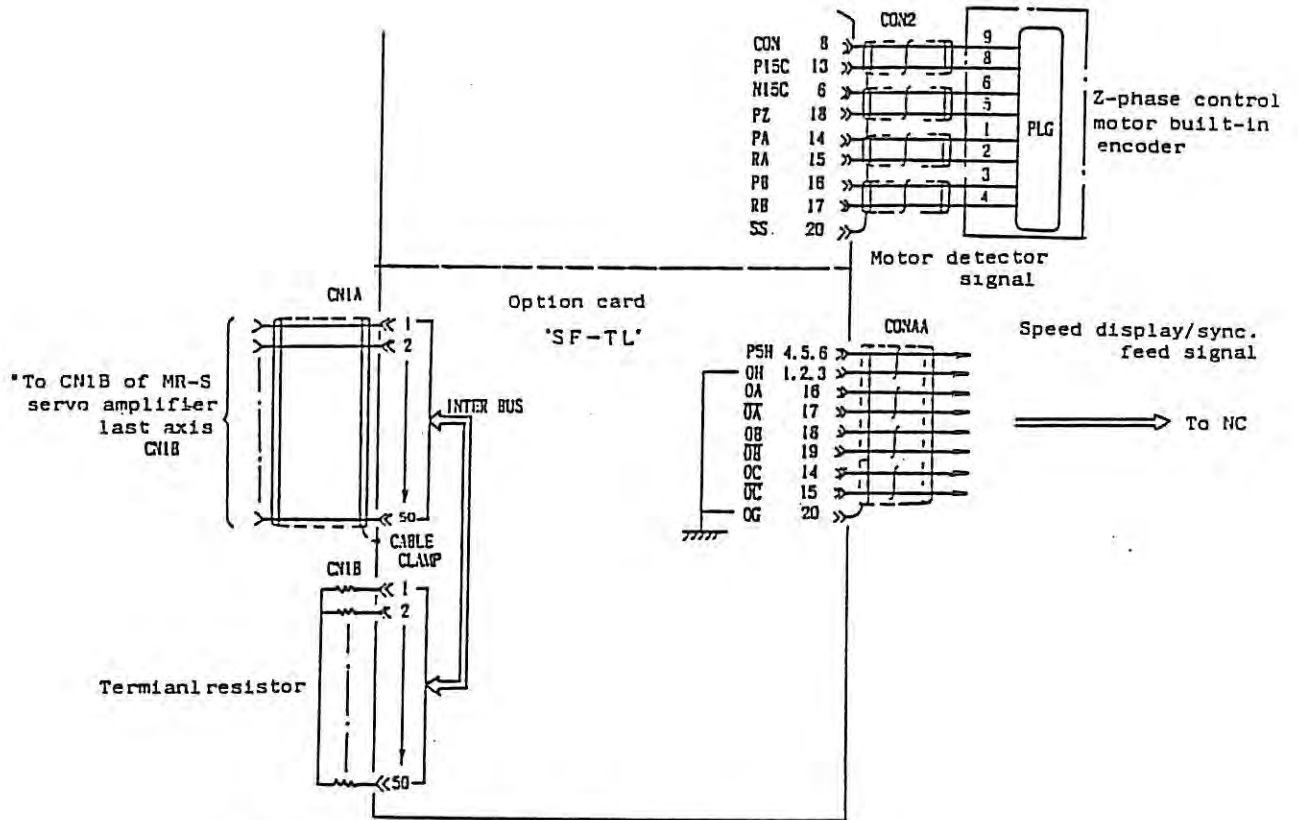

*When cable is used for bus-line connection to M300, it must be shielded with cable clamps (secured to grounding plate). For installation of the cable, refer to the Standard Specification (BNP-A0801-18-E).

2.5.4 Model bus-linked to M300 series CNC

(1) C-axis control magnesensor spindle orientation
(with option card SF-TL) FR-SF-2-□K-T

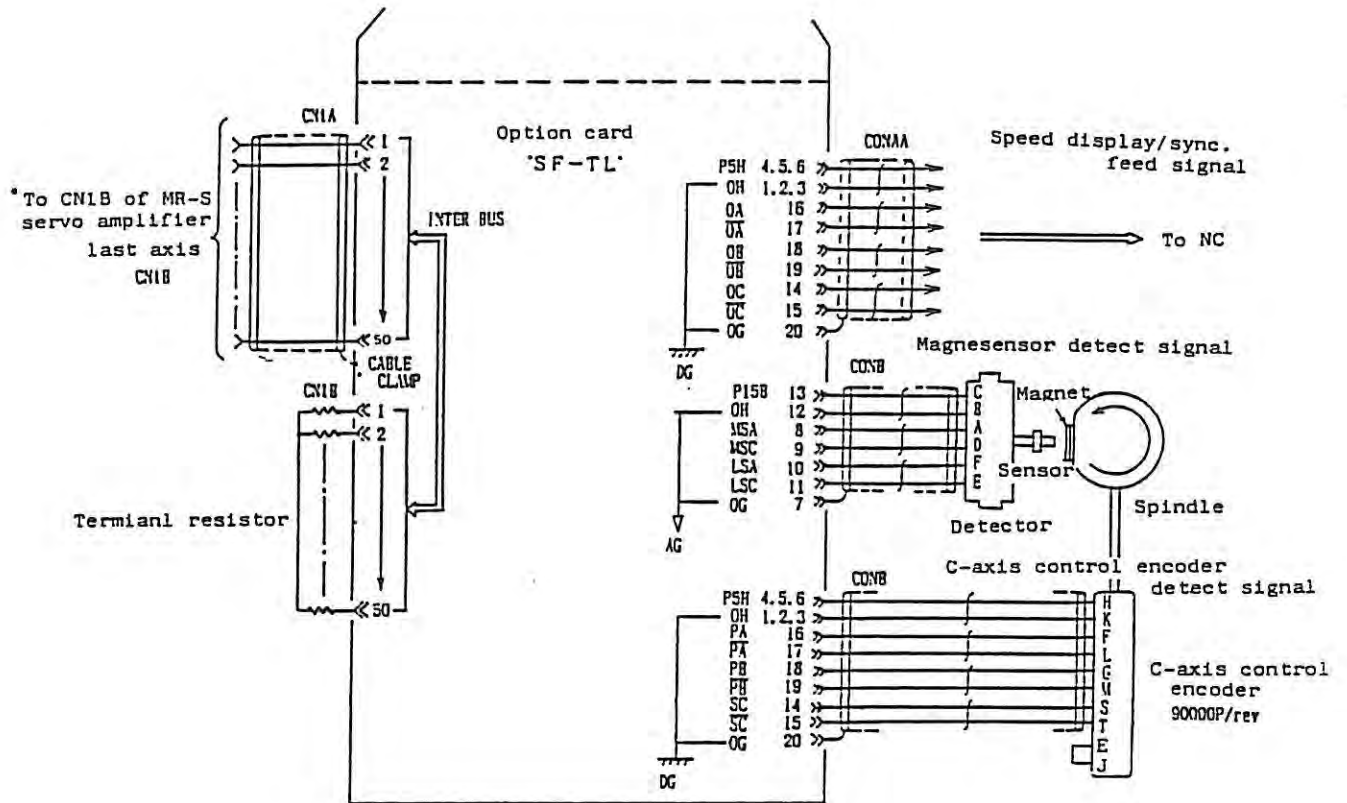

*When cable is used for bus-line connection to M300, it must be shielded with cable clamps (secured to grounding plate). For installation of the cable, refer to the Standard Specification (BNP-A0801-18-E).

2.6 Parts arrangement

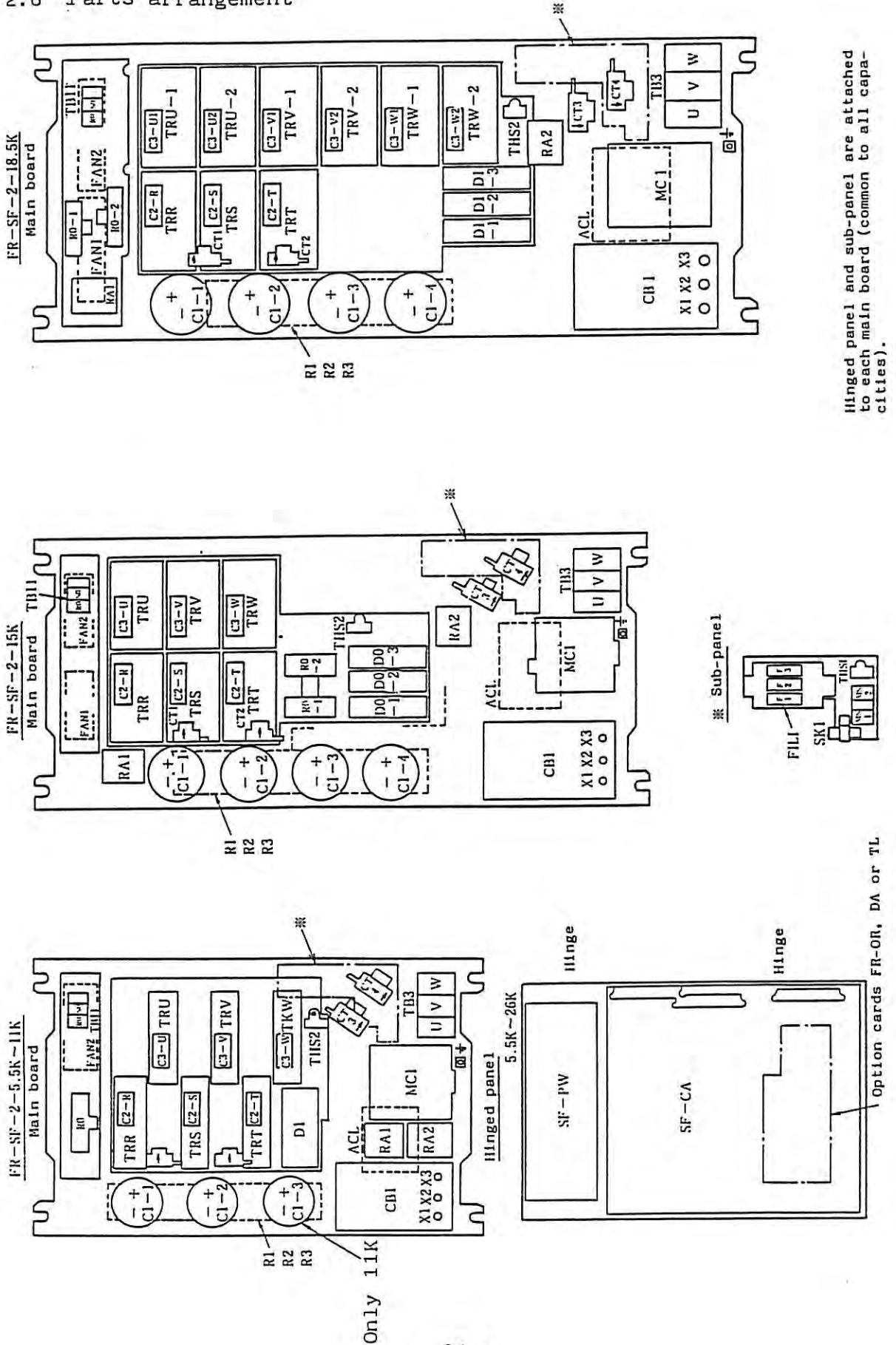

Hinged panel and sub-panel are attached to each main board (common to all capacities).

FR-SF-2-22K.26K
Main board

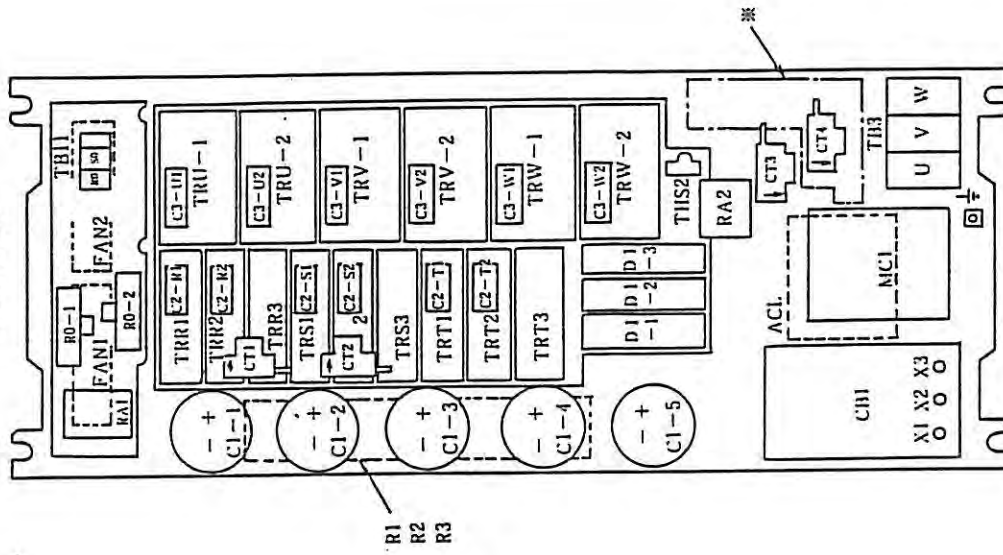

§3. ADJUSTMENT DURING OPERATION

3.1 Preliminary check

Before turning on the controller, perform the following check:

- (1) Is the external wiring in conformity with the relevant drawings or diagrams?
- (2) Are the motor and control equipment grounded properly?
- (3) Are all shielding wires terminated properly?
 - o Is each shield armour connected to the corresponding terminal?
 - o Is each shield armour not looped?
 - o When a cable is used for bus-line connection to M300, it should be secured to the grounding plate with cable clamps.
It the cable secured to the grounding plate?
- (4) Is any component or part not loose?
- (5) Is any foreign matter is not involved?
- (6) Is there any damage or defect on each P.C. board.
- (7) Are ROM No. in accordance with the order sheets?

3.2 Power feeding
 3.2.1 Turning on the power

Immediately after the FR-SF is turned on, see the 7-segment readout at the center of front panel to check conditions:

(1) For FR-SF linked to M300 series CNC

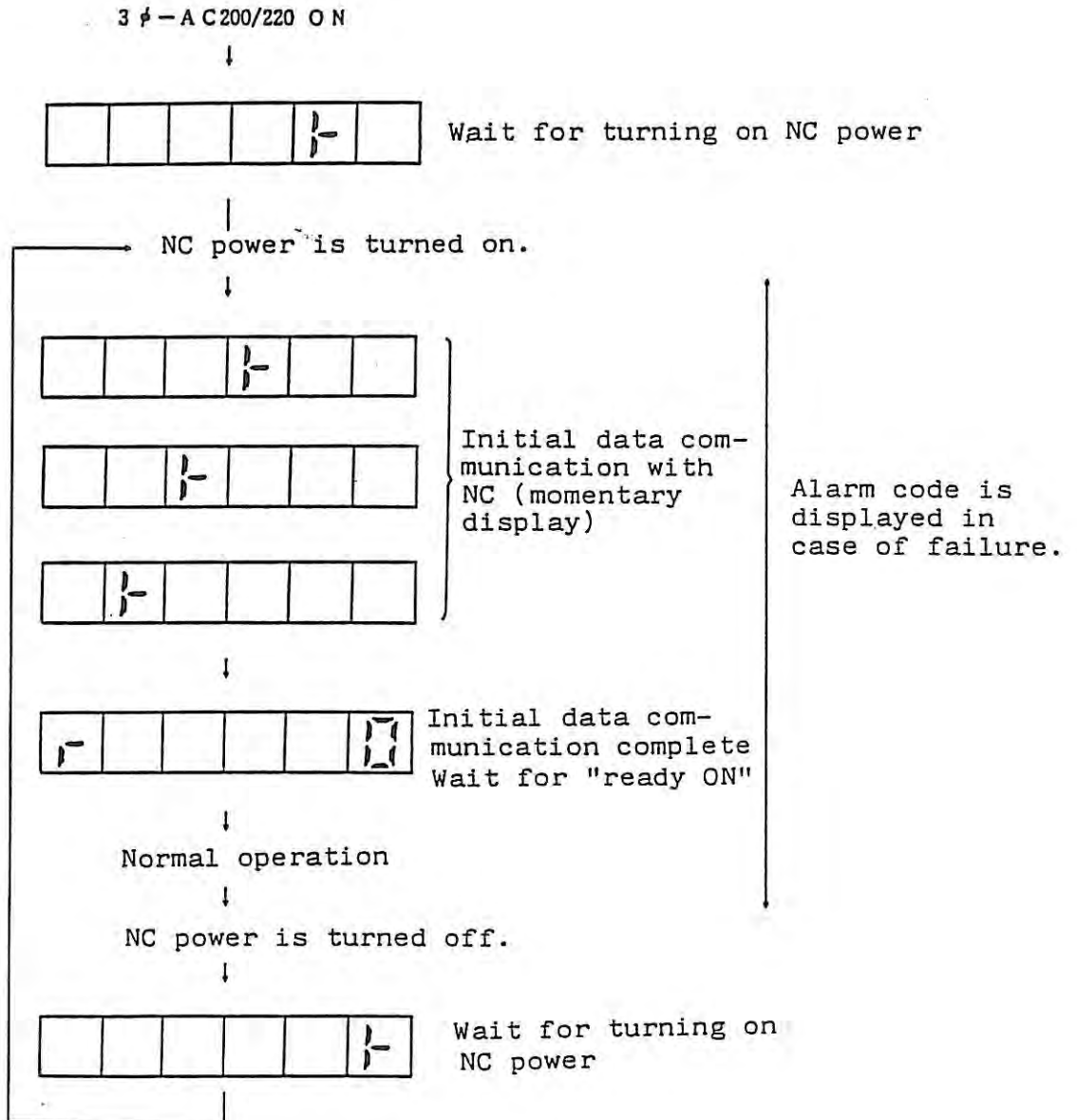

(2) For FR-SF not linked to M300 series CNC

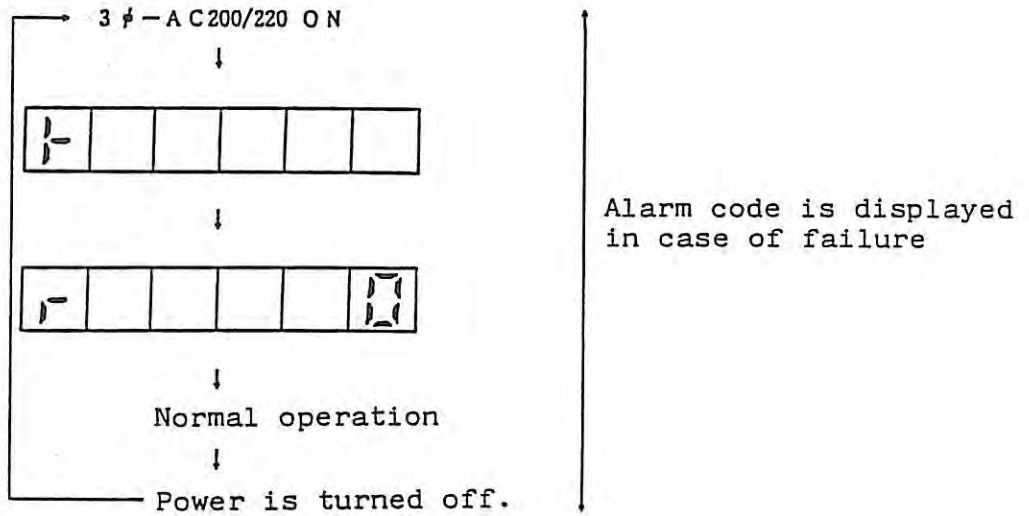

3.3 Status display and parameter setting

1) Readout and switches

The readout and switches shown below are located on the card SF-CA.

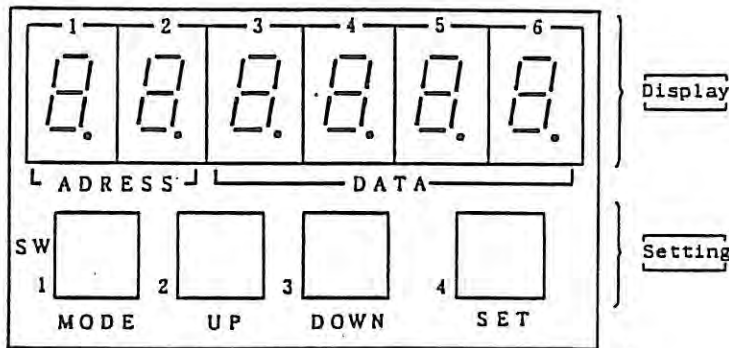

Located on card SF-CA

"Operation status", "diagnosis", "error alarm", "parameter setting (1) - (8)" and "debug" can be displayed.

MODE: Display mode can be changed.

UP: Value displayed in ADDRESS and DATA can be incremented.

DOWN: Value displayed in ADDRESS and DATA can be decremented.

SET: Data set for parameter is stored when this switch is pressed.

- a) There are 12 display modes, namely, "operation status", "disgnosis", "error alarm", "parameter setting (1) - (8)" and "debug".
- b) After turning on the power, "speed" is displayed in operation status mode unless alarm occurs.
- c) In case of alarm, alarm code is displayed in error alarm mode.
- d) Display mode can be changed by pressing switch.

e) For display mode sequence and display content, refer to 4.1.2 "Readout display mode sequence".

2) Readout display mode sequence

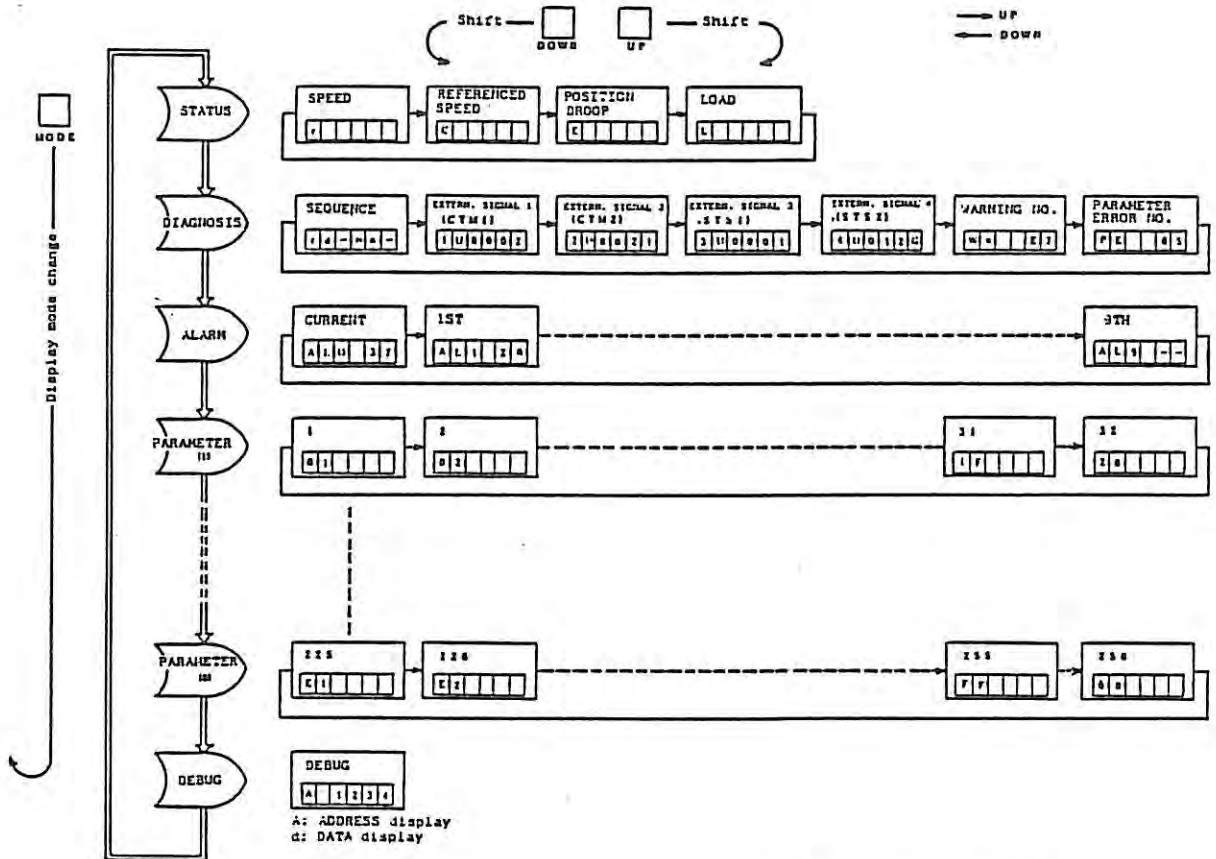

- o Display mode can be selected by pressing **MODE** switch.
- o Display content can be changed in the same display mode by pressing **UP** or **DOWN** switch.

3) Operation status display list

In operation status mode, codes listed below are displayed.

Item	Code	unit	Description
Speed	r	rpm	Motor speed is displayed.
Reference speed	r	rpm	Commanded reference motor speed is displayed.
Position droop	E	Pulses	Number of remaining pulses on deviation counter. For pulses (minus) in reverse rotation, all decimal points light.
Load	L	%	Load condition is displayed (100%: 30 min. rated output)

4) Diagnosis display list

Item	Display	Description
Sequence		Indicates that the controller is ready for operation.
		Indicates that the controller is not ready for operation.

External I/O signals

External I/O signal can be monitored by seeing status of corresponding bit. For relationship between each signal and bit status, refer to the list below.

External signal	F	E	D	C	B	A	9	8	7	6	5	4	3	2	1	0	
STH 100 (Input signal)		CTH Gear select	CTL Gear select					TAP Tap		ORC Orient rotate steer command			TL2 Torque control H	TL1 Torque control L	SRI Reverse run	SRH Forward run	
STH2 100 (Input signal)								PCIG Parameter change	DFIN Data set complete			N. RST NC reset			SVON Servo ON	RDY Ready ON	
STO1 100 (Output signal)								Parameter change	Torque limit	In-position	Z-phase pass		Alarm	Emergency stop	Servo ON	Ready ON	
STO2 100 (Output signal)					PH Phase sequence (Rev. "1")		CCR Reverse run	Forward run		OFIN Orienta- tion in- position	UTS Up to speed	ZS Zero speed	ALM Alarm	SD Speed detect	CD Current detect		

Warning No.

	Display	Description
Warning No.		Indicates that parameter setting is not acceptable.
		Indicates that emergency stop is exerted.

Parameter error No.

	Display	Description
Parameter error No.		Indicates parameter error No.

5) Alarm display mode

Alarm No.

	Display	Description
Alarm No.		Indicates alarm No.

Error alarm display

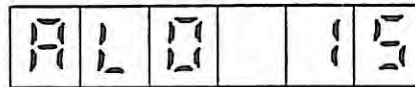

Alarm No. is displayed. For details of alarm No., refer to Appendix 1 "Alarm/warning list".

Concurrent alarms are displayed (AL0 - AL9).

3.3.1 Alarm/warning functions

Alarm No.	Abbr.	Name	Description	(Note) Motion
10	UV	VOLTAGE DOWN	This alarm occurs if input supply voltage goes down below the specified level, or if instantaneous power failure lasting for over 10msec occurs.	A
12	ME1	MEMORY ERROR (FAULT) 1	This alarm occurs if read from, or write to internal memory for controller system control does not go normally (memory is checked when the controller is turned on).	A
15	ME2	MEMORY ERROR (FAULT) 2	This alarm occurs if 2-port memory for data communication (when FR-SF is bus-linked with M300 series CNC) does not function properly.	A
17	BE	PC BOARD ERROR	This alarm occurs if any part of control card is not in good condition.	A
20	NS1	NO SIGNAL 1 (PLG)	This alarm occurs if signal from motor built-in encoder is not at normal level.	A
21	NS2	NO SIGNAL (Spind ENC.)	This alarm occurs if signal from encoder for oriented spindle stop is not input, or not at normal level.	A
22	NSS	IC MAC 012 FAULT	This alarm occurs if IC "MAC 012) of control card does not function properly.	A
23	OSE	SPEED CONTROL ERROR EXCESS	This alarm occurs if difference between true motor speed and referenced speed is excessive.	A
24	BRT	BREAKER TRIP	This alarm occurs if current exceeding the specified limit flows in the main (power) circuit.	A

Alarm No.	Abbr.	Name	Description	(Note) Motion
25	COC	CONVERTER OVERCURRENT	This alarm occurs if current exceeding the specified limit flows in converter.	A
26	PL	POWER PHASE FAILURE	This alarm occurs if any one of three phases of input power supply fails.	A
27	CPUE	CPU FAULT	This alarm occurs if error in arithmetic operation, due to improper parameter setting, occurs.	A
31	OS	OVERSPEED	This alarm occurs if motor speed exceeds 115% of the maximum motor speed.	A
32	OC	OVERVOLTAGE, INVERTER	This alarm occurs if current exceeding the specified limit flows in controller.	A
33	OV	OVERVOLTAGE, CONVERTER	This alarm occurs if voltage charged in main circuit capacitor goes up, due to regenerative brake energy, over the specified limit.	A
34	DP	DATA PARITY CHECK ERROR	This alarm occurs if parity check error occurs in data transmission between M300 series CNC and FR-SF (when FR-SF is bus-linked with CNC).	A
35	DE	DATA ERROR	This alarm occurs if movement command specified by CNC exceeds the specified limit (when FR-SF is bus-linked with CNC).	A
36	TE	DATA TRANSFER ERROR	This alarm occurs if data transfer does not go satisfactorily (when FR-SF is bus-linked with CNC).	A
37	PE	PARAMETER ERROR	This alarm occurs if set parameter value is out of the permissible range (this check is made when the	A

Alarm No.	Abbr.	Name	Description	(Note) Motion
			controller is turned on).	
45	OHF	CONTROLLER OVERHEAT	This alarm occurs if ambient temperature is excessively high, or main (power) circuit semiconductor overheats due to overload or stop of cooling fan.	A
46	OHM	MOTOR OVERHEAT	This alarm occurs if motor overheats due to overload or stop of motor cooling fan.	A
52	OD	ERROR EXCESS	This alarm occurs if difference (error) between referenced position and true position is excessive in position loop control.	A
55	EM	EMERGENCY STOP	This alarm occurs if emergency stop signal is given by external signal source.	B
56	OA	OTHER AXIS FAULT	This alarm occurs if trouble occurs with other servo control axis (when FR-SF is bus-linked with CNC).	A
57	OPE	OPTION CARD ERROR	This alarm occurs if "sync. tap", "C-axis control" or "index function" signal is input while the system is not equipped with that function.	A
E0	IPF	INSTANTANEOUS POWER FAILURE	This warning occurs if input power supply is interrupted or its voltage goes down momentarily.	C
E4	WPE	PARAMETER	If parameter setting is not acceptable, this warning occurs.	C
E7	NCE	NC EMERGENCY	This warning occurs if emergency stop signal is input from CNC (when FR-SF is bus-linked with CNC). This warning occurs if emergency stop signal is input from external	B

Alarm No.	Abbr.	Name	Description	(Note) Motion
			signal source (when external emergency signal is acceptable parameter #42 BSL has been set.	

Note: If protective function listed above is activated, Alarm No. is displayed by 7-segment readout and the following occurs.

Motion A Controller base current is shut off, main (power) circuit contactor opens and the motor stops after coasting.
Fault signal contact FA-FC opens.

Motion B Motor is decelerated by regenerative brake and stops. After motor stops, base current is interrupted.
In this case, whether fault signal contact FA-FC opens or not depends on parameter setting.

Motion C Only warning is displayed (operation can be continued).

3.4 NC display:

Since display (format, content, etc.) and setting method differs from NC to NC, refer to the instruction manual of your NC system.

Typical examples of NC display are described here.

Status display

For status display, [SPINDLE MONITOR] of DIAGNOSIS screen is used. For use of this display function, FR-SF should be bus-linked with NC system.

[SPINDLE MONITOR]		DIAGNOSIS 2.2/2	
GAIN			10.0
DROOP			123456
MOTOR SPEED			6000
MOTOR LOAD			80
SPINDLE ALARM			12 01
			76543210
CONTROL INPUT	L	01010101	
	H	11001100	
CONTROL OUTPUT	L	10101010	
	H	00110011	
MESSAGE	SERVO MONITOR	I/F DIAGNOSIS	NC SPEC. MENU SELECT

Display	Description
GAIN	Position control loop gain is displayed. When position control loop is not used, "0" is displayed. The standard position control loop gain is, $\frac{\text{Motor speed (rad/s)}}{\text{Response delay (rad/s)}} = 10$
DROOP	Error in true spindle angle from referenced spindle angle is called "droop". Droop is expressed in number of pulses. When position control loop is not used, "0" is displayed.

Display	Description																																																																																
MOTOR SPEED	True motor speed is displayed in rpm.																																																																																
MOTOR LOAD	Load is displayed in ratio(%) to motor rated output (capacity). The output rated for 30 min. is 100%. Range of display is from 0 to 120%.																																																																																
SPINDLE ALARM	If fault occurs with spindle amplifier, alarm is displayed with code No. (current alarm and previous alarm are displayed). For alarm contents, refer to Appendix 2.																																																																																
CONTROL INPUT	Signal input to spindle amplifier is displayed by bit. <table border="1" style="width: 100%; border-collapse: collapse;"> <thead> <tr> <th colspan="8">CONTROL INPUT II</th> <th colspan="8">CONTROL INPUT L</th> </tr> <tr> <th>7</th><th>6</th><th>5</th><th>4</th><th>3</th><th>2</th><th>1</th><th>0</th> <th>7</th><th>6</th><th>5</th><th>4</th><th>3</th><th>2</th><th>1</th><th>0</th> </tr> </thead> <tbody> <tr> <td colspan="4" style="text-align: center;">Gear select</td> <td colspan="4"></td> <td colspan="4"></td> <td colspan="4" style="text-align: center;">Tapping</td> </tr> <tr> <td colspan="8" style="text-align: center;"> (0 0 : GEAR 0 0) (0 1 : GEAR 0 1) (1 0 : GEAR 1 0) (1 1 : GEAR 1 1) </td> <td colspan="8" style="text-align: center;"> Oriented spindle stop command C.CW Index CW Index Torque limit H Torque limit L Reverse run Forward run </td> </tr> </tbody> </table>	CONTROL INPUT II								CONTROL INPUT L								7	6	5	4	3	2	1	0	7	6	5	4	3	2	1	0	Gear select												Tapping				(0 0 : GEAR 0 0) (0 1 : GEAR 0 1) (1 0 : GEAR 1 0) (1 1 : GEAR 1 1)								Oriented spindle stop command C.CW Index CW Index Torque limit H Torque limit L Reverse run Forward run																							
CONTROL INPUT II								CONTROL INPUT L																																																																									
7	6	5	4	3	2	1	0	7	6	5	4	3	2	1	0																																																																		
Gear select												Tapping																																																																					
(0 0 : GEAR 0 0) (0 1 : GEAR 0 1) (1 0 : GEAR 1 0) (1 1 : GEAR 1 1)								Oriented spindle stop command C.CW Index CW Index Torque limit H Torque limit L Reverse run Forward run																																																																									
CONTROL OUTPUT	Signal output from spindle amplifier is displayed by bit. <table border="1" style="width: 100%; border-collapse: collapse;"> <thead> <tr> <th colspan="8">CONTROL OUTPUT II</th> <th colspan="8">CONTROL OUTPUT L</th> </tr> <tr> <th>7</th><th>6</th><th>5</th><th>4</th><th>3</th><th>2</th><th>1</th><th>0</th> <th>7</th><th>6</th><th>5</th><th>4</th><th>3</th><th>2</th><th>1</th><th>0</th> </tr> </thead> <tbody> <tr> <td colspan="4"></td> <td colspan="4" style="text-align: center;">Phase sequence (Rev. "1")</td> <td colspan="4"></td> <td colspan="4" style="text-align: center;">Reverse run</td> </tr> <tr> <td colspan="4"></td> <td colspan="4"></td> <td colspan="4"></td> <td colspan="4" style="text-align: center;">Forward run</td> </tr> <tr> <td colspan="8" style="text-align: center;">Oriented spindle stop completed</td> <td colspan="8" style="text-align: center;"> Up to speed Zero speed Alarm Speed detect Load detect </td> </tr> </tbody> </table>	CONTROL OUTPUT II								CONTROL OUTPUT L								7	6	5	4	3	2	1	0	7	6	5	4	3	2	1	0					Phase sequence (Rev. "1")								Reverse run																Forward run				Oriented spindle stop completed								Up to speed Zero speed Alarm Speed detect Load detect							
CONTROL OUTPUT II								CONTROL OUTPUT L																																																																									
7	6	5	4	3	2	1	0	7	6	5	4	3	2	1	0																																																																		
				Phase sequence (Rev. "1")								Reverse run																																																																					
												Forward run																																																																					
Oriented spindle stop completed								Up to speed Zero speed Alarm Speed detect Load detect																																																																									

Appendix 1 Spindle alarm list

No.	Content	No.	Content	
10	Voltage down	PR	40 TR-TK unit switching failure	NR
11			41 FR-TK unit communication failure	NR
12	Memory fault 1	AR	42	NR
13	External clock fault		43	NR
14			44	NR
15	Memory fault 2	PR	45 Controller overheat	NR
16			46 Motor overheat	NR
17	Card fault	PR	47	NR
20	No signal 1 (PLG)	PR	50	NR
21	No signal 2 (Spindle ENC)	PR	51	NR
22	IC MAC012 fault	PR	52 Error excess	NR
23	Speed control error excess	PR	53	NR
24	Breaker trip/main circuit fault	PR	54	NR
25	Converter overcurrent/brake fault	PR	55	NR
26	Power phase failure	PR	56 Other axis fault	NR
27	CPU fault		57 Option card error	NR
30			E0 Instantaneous power failure warning	*
31	Overspeed	PR	E1	*
32	Inverter overcurrent/overcurrent	PR	E2	
33	Overvoltage	PR	E3	
34	Data parity check error	PR	E4 Parameter error warning	*
35	Data fault	PR	E5	
36	Data transfer fault	PR	E6	
37	Parameter error	PR	E7 NC emergency stop	

PR: Reset by turning off power supply of NC

AR: Reset by turning off power supply of spindle amplifier

NR: NC reset

*: "Servo OFF" does not occur.

3.5 Parameter setting

Parameters can be set through the readout and switches of card SF-CA of FR-SF.

(When the controller SR-SF is bus-linked with M300 series CNC, a part of parameters can be set by the NC display unit.)

3.5.1 Parameter setting

1) Layout of readout and switches

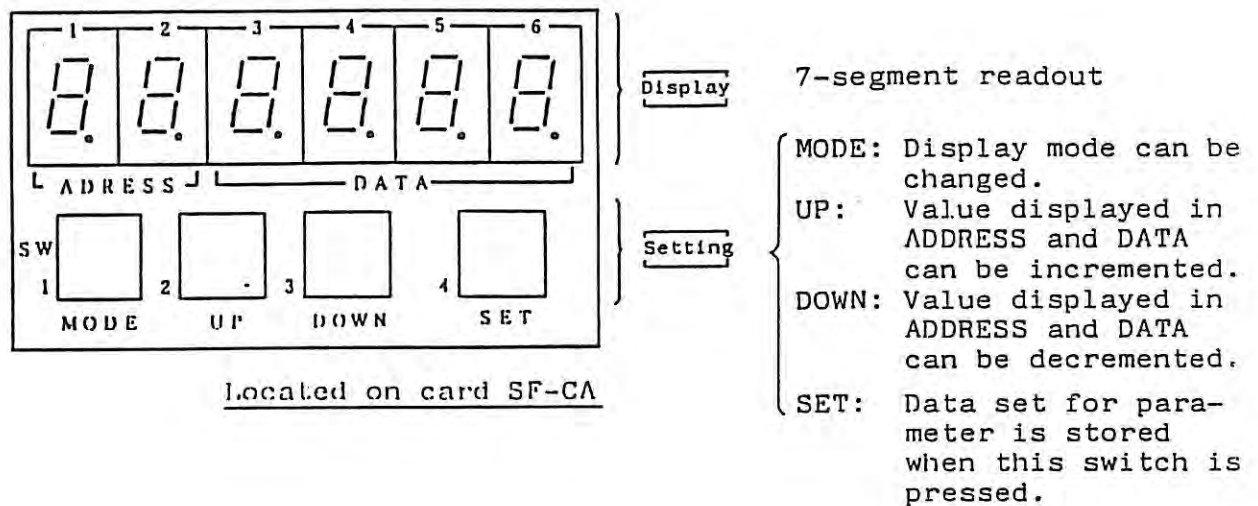

2) Parameter setting

To specify parameter, set "SET1" and "SET2" (machine ready for operation) to "OFF".

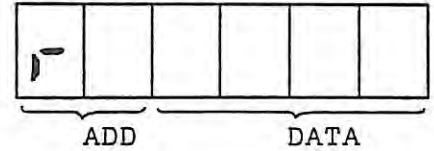
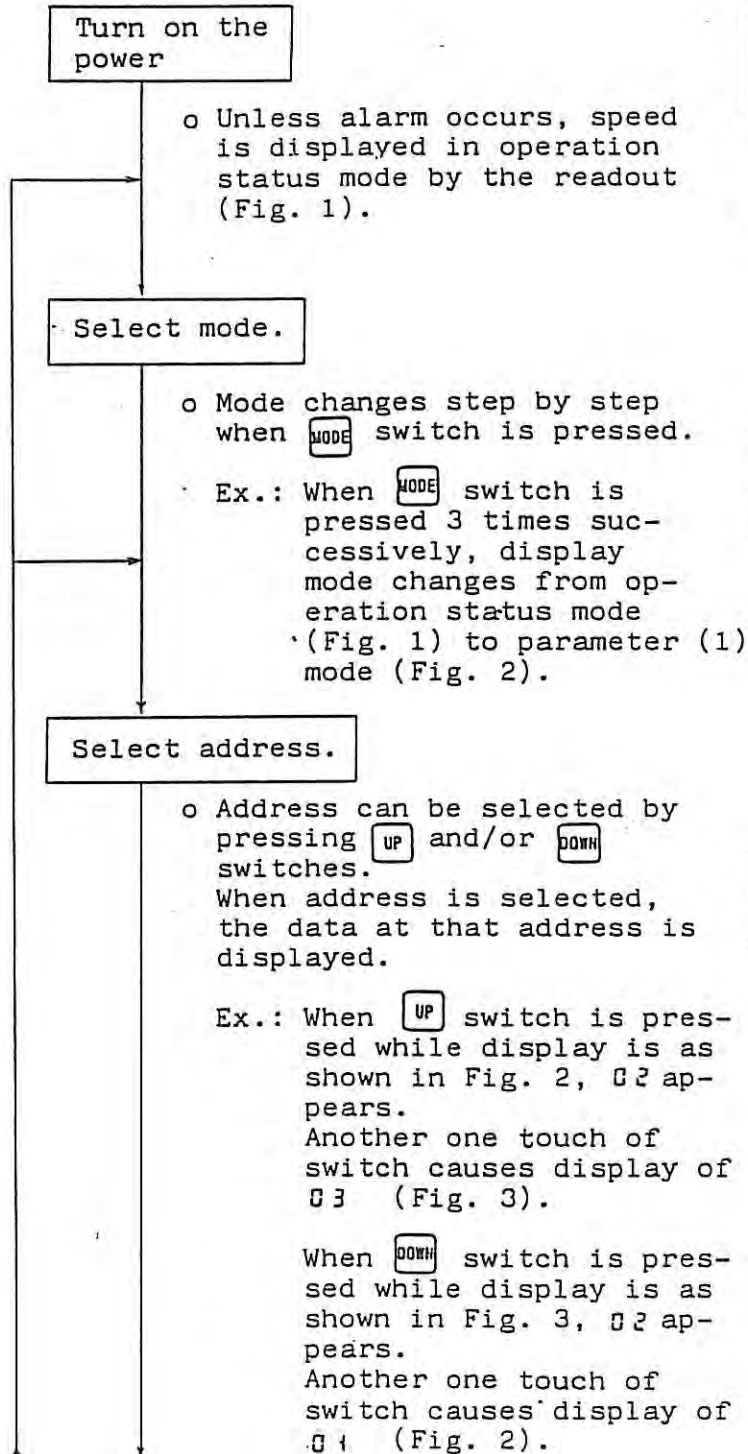

Fig. 1 SPEED display

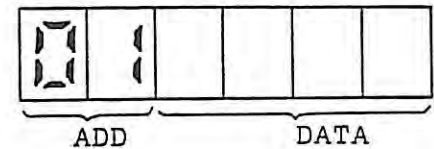

Fig. 2

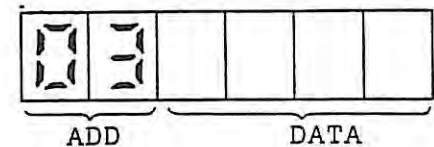

Fig. 3

Data rewrite

- o To rewrite previously set data, press **SET** switch.

When the switch is pressed, LEDs ADD flickers indicating that data can be rewritten.

- o Set desired data by pressing **UP** and/or **DOWN** switches.

Value can be incremented by pressing **UP** switch, and decremented by pressing **DOWN** switch.

Value changes continuously while switch is held down.

- o When **SET** switch is pressed again, newly set data is stored.

After the switch is pressed, LEDs ADD light continuously.

Data set completed

- o Press **PB 1** switch and reset the FR-SE (or turn off and then on the power).

Now data setting has been completed.

Parameter table

#	Parameter		Description	Setting range (unit)
01	NOX	Motor type	<p>Setting depends on motor specification.</p> <p>0: Standard/quasi-standard specification</p> <p>1: Wide range output specification</p> <p>2: Other special specification</p>	Decimal notation
02	MLS	Motor selection	<p>Motor constant can be selected (ranging from "0" to "63") for motor used.</p> <p>(Refer to "Motor Parameter list".)</p>	Decimal notation
03	PLG	Position loop encoder type	<p>Setting depends on number of pulses, specific to encoder used.</p> <p>0: 1024 pulses (encoder orient taperless)</p> <p>1: 90,000 pulses (for C-axis control)</p>	Decimal notation
04	MOD	External interface mode selection	<p>Setting depends on type of interface with NC used.</p> <p>0: DIO (specification is same as that of FRSE)</p> <p>2: Linked to M300 series CNC through 2-port bus</p>	Decimal notation

#	Parameter		Description	Setting range (unit)
05	DSR	Speed reference signal type	<p>Setting depends on input speed reference signal type.</p> <p>This parameter is valid when #04 MOD is set to "0".</p> <p>0: 12-bit binary 1: Signed 12-bit binary 2: BCD (2 digits) 3: BCD (3 digits)</p> <p>When signal is analog, either "0" or "1" is selected. For digital signal, one is selected from "0" - "3".</p>	Decimal notation
06	MON	Output monitor selection	<p>Setting depends on type of meter output (analog voltage) from card SF-CA.</p> <p>0: Load meter 1: Torque meter</p> <p>Standard setting: 0</p>	Decimal notation
07	O1SL		Not used Set "0".	
08	O2SL		Not used Set "0".	
09	I1SL	Auxiliary input selection	<p>TL1/TL2 input functions are set.</p> <p>0: Torque control input 1: Index input</p>	Decimal notation
0A	I2SL		Not used Set "0".	
0B	VOP	Speed reference offset	<p>Offset is set when analog speed reference signal is used.</p> <p>Standard setting: 0</p>	Signed decimal notation (-999 ≤ ≤+999)
0C	VON		Not used Set "0".	

#	Parameter		Description	Setting range (unit)
OD	VGP	Speed reference signal gain	Gain for speed reference signal is set. Actual speed reference is product obtained by multiplying speed reference signal from external signal source by this setting (1 multiplier = 1000). Standard setting: 1000	Decimal notation (0 ≤ ≤1150)
OE	VGN		Not used Set "0".	
OF	CSN2	2nd cushion time constant	Not used Set "0".	Decimal notation
10	DTYP	Data type	Whether data of parameters #11 ~ #20 are valid or invalid depends on this setting. 0: Invalid 1: Valid When "1" is selected, data set for parameters #11 ~ #20 become valid for input signal to connector CONC of card SF-OR. For details, refer to Specification "BNP-A0801-22".	Decimal notation
11 12 13 14 15 16 17 18 19 1A 1B 1C	DT01 DT02 DT03 DT04 DT05 DT06 DT07 DT08 DT09 DT10 DT11 DT12	Data 1 Data 2 Data 3 Data 4 Data 5 Data 6 Data 7 Data 8 Data 9 Data 10 Data 11 Data 12	These data are valid when "1" is set for #10 parameter (data type). Speed reference signal selected by speed select signal is set for each data. Data is set in terms of motor speed within the range up to the motor maximum speed set by #31 TSP.	Decimal notation

#	Parameter		Description	Setting range (unit)	
1D	DT13		Not used Set "0".		
1E	DT14		Not used Set "0".		
1F	DT15		Not used Set "0".		
20	DT16		Not used Set "0".		
* 21	PG1	Spindle orientation 1st deceleration point	Encoder spindle orientation: Angle from which creep speed starts is set. Standard setting: 180 Magnesensor spindle orientation: Time taken for start of creep speed after passing over linear zone is set. Standard setting: 133	Encoder 0 - 359 deg.	Magne-sensor 0 - 500 ms
* 22	PG2	Spindle orientation 2nd deceleration point	Angle at which creep speed for spindle orientation starts is set. Standard setting: 20		0 - 40 deg.
* 23	PGC	Sync. tap C-axis control position loop gain	Spindle position loop gain during sync. tap C-axis control is set. Standard setting: 40 (NC display standard setting: 10.00)	1 - 512 (1/4rad/s) 0.01 - 999.99 (rad/s) for parameter on NC display	
* 24	ZRZ	Spindle orientation in-position range	Positioning range within which "orientation complete" signal is output is set. Standard settings: Encoder type oriented spindle stop 16 Mangnesensor type oriented spindle stop 80 (NC display standard setting: 1.00)	Encoder 1 - 5760 (1/16 deg.)	Magne-sensor 1 - 512 (1/16 deg.) For parameter on NC display 0 - 39 deg.

#	Parameter		Description	Setting range (unit)	
* 25	OSP	Spindle orientation speed	Speed at which spindle is oriented is set. Standard setting: 220	0 - 1000rpm	
* 26	CSP	Creep speed	Creep speed is set. Standard setting: 20	0 - 1000rpm	
* 27	PST	Position shift	Oriented spindle stop position is set. Encoder: Stop position is set within 360 deg. with increment of 360/4096. Magnesensor: Stop position is set within range from -5 deg. to +5 deg. with increment 10/1024 (2048 for 0 deg.). Standard setting: 2048	Encoder 0 - 4095	Magne-sensor 1536 - 2560
* 28	BRC		Not used Set "0".		
* 29			Not used Set "0".		
	2A		Not used Set "0".		
	2B		Not used Set "0".		
	2C		Not used Set "0".		
	2D		Not used Set "0".		
	2E		Not used Set "0".		

Note: Parameter marked with * is set on the NC side when FR-SF is bus-linked to M300 series CNC.

No.	Parameter	Description	Setting range (unit)																																																																				
* 2F	ORS1	Oriented spindle stop control 1	Hexadecimal notation																																																																				
		<table border="1" style="width: 100%; text-align: center;"> <tr> <td>F</td><td>E</td><td>D</td><td>C</td> <td>B</td><td>A</td><td>9</td><td>8</td> <td>7</td><td>6</td><td>5</td><td>4</td> <td>3</td><td>2</td><td>1</td><td>0</td> </tr> <tr> <td colspan="4">Oriented spindle stop K_I magnif.</td> <td colspan="4">Oriented spindle stop K_r magnif.</td> <td colspan="4"></td> <td>Servo lock control</td> <td colspan="4">ω_r select [rad/s]</td> </tr> <tr> <td colspan="4"> </td> <td colspan="4"> </td> <td colspan="4"> </td> <td> </td> <td colspan="4"> </td> </tr> </table>	F	E	D	C	B	A	9	8	7	6	5	4	3	2	1	0	Oriented spindle stop K_I magnif.				Oriented spindle stop K_r magnif.								Servo lock control	ω_r select [rad/s]																																							
F	E	D	C	B	A	9	8	7	6	5	4	3	2	1	0																																																								
Oriented spindle stop K_I magnif.				Oriented spindle stop K_r magnif.								Servo lock control	ω_r select [rad/s]																																																										
		<table style="width: 100%; border-collapse: collapse;"> <tr> <td style="width: 25%; text-align: center;">4-bit combination</td> <td style="width: 25%; text-align: center;">4-bit combination</td> <td style="width: 25%; text-align: center;">Delay/advance</td> <td style="width: 25%; text-align: center;">4-bit combination</td> </tr> <tr> <td>0 : 0.6 (folds)</td> <td>0 : 0.6 (folds)</td> <td>0 : P I</td> <td>0 : 0.55 (rad/s)</td> </tr> <tr> <td>1 : 0.7</td> <td>1 : 0.7</td> <td></td> <td>1 : 0.1</td> </tr> <tr> <td>2 : 0.8</td> <td>2 : 0.8</td> <td></td> <td>2 : 1.65</td> </tr> <tr> <td>3 : 0.9</td> <td>3 : 0.9</td> <td></td> <td>3 : 2.2</td> </tr> <tr> <td>4 : 1</td> <td>4 : 1</td> <td></td> <td>4 : 2.75</td> </tr> <tr> <td>5 : 1.2</td> <td>5 : 1.2</td> <td></td> <td>5 : 3.3</td> </tr> <tr> <td>6 : 1.4</td> <td>6 : 1.4</td> <td></td> <td>6 : 3.85</td> </tr> <tr> <td>7 : 1.6</td> <td>7 : 1.6</td> <td></td> <td>7 : 4.4</td> </tr> <tr> <td>8 : 1.8</td> <td>8 : 1.8</td> <td></td> <td>8 : 4.95</td> </tr> <tr> <td>9 : 2</td> <td>9 : 2</td> <td></td> <td>9 : 5.5</td> </tr> <tr> <td>A : 2.2</td> <td>A : 2.2</td> <td></td> <td>A : 6.05</td> </tr> <tr> <td>B : 2.4</td> <td>B : 2.4</td> <td></td> <td>B : 6.6</td> </tr> <tr> <td>C : 2.6</td> <td>C : 2.6</td> <td></td> <td>C : 7.15</td> </tr> <tr> <td>D : 2.8</td> <td>D : 2.8</td> <td></td> <td>D : 7.7</td> </tr> <tr> <td>E : 3</td> <td>E : 3</td> <td></td> <td>E : 8.25</td> </tr> <tr> <td>F : 3.2</td> <td>F : 3.2</td> <td></td> <td>F : 8.8</td> </tr> </table>	4-bit combination	4-bit combination	Delay/advance	4-bit combination	0 : 0.6 (folds)	0 : 0.6 (folds)	0 : P I	0 : 0.55 (rad/s)	1 : 0.7	1 : 0.7		1 : 0.1	2 : 0.8	2 : 0.8		2 : 1.65	3 : 0.9	3 : 0.9		3 : 2.2	4 : 1	4 : 1		4 : 2.75	5 : 1.2	5 : 1.2		5 : 3.3	6 : 1.4	6 : 1.4		6 : 3.85	7 : 1.6	7 : 1.6		7 : 4.4	8 : 1.8	8 : 1.8		8 : 4.95	9 : 2	9 : 2		9 : 5.5	A : 2.2	A : 2.2		A : 6.05	B : 2.4	B : 2.4		B : 6.6	C : 2.6	C : 2.6		C : 7.15	D : 2.8	D : 2.8		D : 7.7	E : 3	E : 3		E : 8.25	F : 3.2	F : 3.2		F : 8.8	
4-bit combination	4-bit combination	Delay/advance	4-bit combination																																																																				
0 : 0.6 (folds)	0 : 0.6 (folds)	0 : P I	0 : 0.55 (rad/s)																																																																				
1 : 0.7	1 : 0.7		1 : 0.1																																																																				
2 : 0.8	2 : 0.8		2 : 1.65																																																																				
3 : 0.9	3 : 0.9		3 : 2.2																																																																				
4 : 1	4 : 1		4 : 2.75																																																																				
5 : 1.2	5 : 1.2		5 : 3.3																																																																				
6 : 1.4	6 : 1.4		6 : 3.85																																																																				
7 : 1.6	7 : 1.6		7 : 4.4																																																																				
8 : 1.8	8 : 1.8		8 : 4.95																																																																				
9 : 2	9 : 2		9 : 5.5																																																																				
A : 2.2	A : 2.2		A : 6.05																																																																				
B : 2.4	B : 2.4		B : 6.6																																																																				
C : 2.6	C : 2.6		C : 7.15																																																																				
D : 2.8	D : 2.8		D : 7.7																																																																				
E : 3	E : 3		E : 8.25																																																																				
F : 3.2	F : 3.2		F : 8.8																																																																				
		Standard setting: 7701																																																																					

Note: Parameter marked with * is set on the NC side when FR-SF is bus-linked to M300 series CNC.

No.	Parameter	Description	Setting range (unit)																																
* 30	ORS2 Oriented spindle stop control 2	<table border="1" style="width: 100%; border-collapse: collapse; text-align: center;"> <tr> <td style="width: 5%;">F</td><td style="width: 5%;">E</td><td style="width: 5%;">D</td><td style="width: 5%;">C</td><td style="width: 5%;">B</td><td style="width: 5%;">A</td><td style="width: 5%;">9</td><td style="width: 5%;">8</td><td style="width: 5%;">7</td><td style="width: 5%;">6</td><td style="width: 5%;">5</td><td style="width: 5%;">4</td><td style="width: 5%;">3</td><td style="width: 5%;">2</td><td style="width: 5%;">1</td><td style="width: 5%;">0</td> </tr> <tr> <td style="font-size: 8px;">+ve rotation direction, position lim</td><td style="font-size: 8px;">-ve rotation direction, position lim</td><td></td><td></td><td style="font-size: 8px;">Intense excitation, position lim</td><td style="font-size: 8px;">Close/semi-closed, position lim</td><td style="font-size: 8px;">+ve rotation direction, position lim</td><td style="font-size: 8px;">-ve rotation direction, position lim</td><td style="font-size: 8px;">Spindle direction, orientation</td><td></td><td></td><td></td><td></td><td></td><td colspan="2" style="font-size: 8px;">Direction of rotation, spindle orientation</td> </tr> </table> <div style="display: flex; justify-content: space-between;"> <div style="width: 45%;"> <p>0: (+) direction 1: (-) direction</p> <p>0: (+) direction 1: (-) direction</p> <p>0: Closed 1: Semi-closed</p> <p>0: Faint excitation 1: Intense excitation</p> <p>0: (+) direction 1: (-) direction</p> <p>0: (+) direction 1: (-) direction</p> </div> <div style="width: 50%;"> <p>2-bit combination</p> <p>0: PRE 1: CW 2: CCW 3: Prohibited</p> <p>[PRE Same as previous direction] Normally PRE is set.</p> </div> </div> <p style="text-align: center; margin-top: 20px;">Standard setting: 0</p>	F	E	D	C	B	A	9	8	7	6	5	4	3	2	1	0	+ve rotation direction, position lim	-ve rotation direction, position lim			Intense excitation, position lim	Close/semi-closed, position lim	+ve rotation direction, position lim	-ve rotation direction, position lim	Spindle direction, orientation						Direction of rotation, spindle orientation		Hexadecimal notation
F	E	D	C	B	A	9	8	7	6	5	4	3	2	1	0																				
+ve rotation direction, position lim	-ve rotation direction, position lim			Intense excitation, position lim	Close/semi-closed, position lim	+ve rotation direction, position lim	-ve rotation direction, position lim	Spindle direction, orientation						Direction of rotation, spindle orientation																					

Note: Parameter marked with * is set on the NC side when FR-SF is bus-linked to M300 series CNC.

#	Parameter		Description	Setting range (unit)
* 31	TSP	Motor maximum speed	The maximum speed of motor depends on this setting.	1 - 3276(10rpm) 10 - 32760(rpm) for parameter setting on NC display
* 32	ZSP	Zero speed	Speed at which "zero speed" is output is set. Standard setting: 50	1 - 1000(rpm)
* 33	CSN	Acceleration time constant	Time for acceleration to referenced speed from zero speed is set (invalid for position loop control). Standard setting: 30 (300 for parameter setting on NC display)	2 - 3276(10msec) 20 - 3276(msec) for parameter setting on NC display
* 34	SDT	Speed detection ratio	Speed at which "speed detect" signal is output is set in terms of percentage to motor maximum speed. Standard setting: 10	0 - 100(%)
* 35	TLM	Torque limit	Torque limit is set in terms of percentage for torque limit signal TL2 (TLH). Standard setting: 10	0 - 120(%)
* 36	VKP	Speed loop proportional gain	Proportional gain is set for speed control loop. The larger the setting (100 - 150), the faster is the response, but the larger is the noise and vibration. Standard setting: 63	0 - 1000 (rad/s)

#	Parameter		Description	Setting range (unit)
* 37	VKI	Speed loop integral gain	<p>Integral gain is set for speed control loop.</p> <p>It should be set so that its ratio to proportional gain VKP is almost constant.</p> <p>Standard setting: 60</p>	0 - 1000 (1/10rad/s)
* 38	TYP	Position loop "IN" type	<p>Setting is made for transition from "speed loop" to "position loop".</p> <p>0: Position control loop "IN" after spindle orientation</p> <p>1: Position control loop "IN" at the time control loop mode is switched</p> <p>Set "0" when initialization (home return) is required, otherwise set "1".</p> <p>Standard setting: 0</p> <p>For C-axis control,</p> <p>0: Initialization by means of encoder</p> <p>I: Initialization by means of dog</p>	Decimal notation
* 39	GRA1	Number of gear teeth on spindle side	Number of gear teeth for gear 00 is converted into hexadecimal value, and set.	1 - 7FFF(HEX) For NC display, its range is 1 - 32767 (decimal) and conversion into hexadecimal value is not required. Gear ratio is set with gear teeth on spindle side, and gear
* 3A	GRA2		Number of gear teeth for gear 01 is converted into hexadecimal value, and set.	
* 3B	GRA3		Number of gear teeth for gear 10 is converted into hexadecimal value, and set.	

#	Parameter		Description	Setting range (unit)
* 3C	GRA4		Number of gear teeth for gear 11 is converted into hexadecimal value, and set.	teeth on motor side. $\left[\begin{array}{l} \text{Spindle speed } z \\ \frac{\text{Spindle side gear teeth (CNA1 - 4)}}{\text{Motor side gear teeth (CNB1 - 4)}} \\ = \text{Motor speed} \end{array} \right]$
* 3D	GRB1	Number of gear teeth on motor side	Number of gear teeth for gear 00 is converted into hexadecimal value, and set.	1 - 7FFF(HEX) For NC display, its range is 1 - 32767 (decimal) and conversion into hexadecimal value is not required. Gear ratio is set with gear teeth on single side, and gear teeth on motor side.
* 3E	GRB2		Number of gear teeth for gear 01 is converted into hexadecimal value, and set.	
* 3F	GRB3		Number of gear teeth for gear 10 is converted into hexadecimal value, and set.	
* 40	GRB4		Number of gear teeth for gear 11 is converted into hexadecimal value, and set.	
41	OSL		Spindle orientation type	
41	OSL	Spindle orientation type	Type of spindle orientation is set. 0: Motor built-in encoder 1: Encoder 2: Magnesensor	Hexadecimal notation

Note: Parameter marked with * is set on the NC side when FR-SF is bus-linked to M300 series CNC.

No.	Parameter	Description	Setting range (unit)																																
42	BSK Bit assignment	<table border="1" style="width: 100%; text-align: center; border-collapse: collapse;"> <tr> <td style="width: 5%;">F</td><td style="width: 5%;">E</td><td style="width: 5%;">D</td><td style="width: 5%;">C</td><td style="width: 5%;">B</td><td style="width: 5%;">A</td><td style="width: 5%;">9</td><td style="width: 5%;">8</td><td style="width: 5%;">7</td><td style="width: 5%;">6</td><td style="width: 5%;">5</td><td style="width: 5%;">4</td><td style="width: 5%;">3</td><td style="width: 5%;">2</td><td style="width: 5%;">1</td><td style="width: 5%;">0</td> </tr> <tr> <td></td><td></td><td></td><td style="font-size: 8px;">Position com- mand, oriented spindle stop</td><td></td><td></td><td></td><td style="font-size: 8px;">Speed reference input</td><td></td><td></td><td></td><td style="font-size: 8px;">Load meter output</td><td></td><td style="font-size: 8px;">Mach input, NC mode</td><td style="font-size: 8px;">Mach input, NC mode</td><td style="font-size: 8px;">Alarm signal in case of DNC</td> </tr> </table> <p style="margin-left: 40px;"> Position command, oriented spindle stop 0: Open emitter 1: Open collector </p> <p style="margin-left: 100px;"> Speed reference input 0: Open emitter 1: Open collector </p> <p style="margin-left: 180px;"> Load meter output 0: Load meter output 10V 1: Load meter output 1V </p> <p style="margin-left: 200px;"> Mach input, NC mode 0: Invalid 1: Valid </p> <p style="margin-left: 200px;"> Mach input, NC mode 0: Invalid 1: Valid </p> <p style="margin-left: 200px;"> Alarm signal in case of DNC 0: Output 1: Not output </p> <p style="margin-left: 200px;"> External EFG, NC mode 0: Invalid 1: Valid </p>	F	E	D	C	B	A	9	8	7	6	5	4	3	2	1	0				Position com- mand, oriented spindle stop				Speed reference input				Load meter output		Mach input, NC mode	Mach input, NC mode	Alarm signal in case of DNC	Hexadecimal notation
F	E	D	C	B	A	9	8	7	6	5	4	3	2	1	0																				
			Position com- mand, oriented spindle stop				Speed reference input				Load meter output		Mach input, NC mode	Mach input, NC mode	Alarm signal in case of DNC																				

Note: Parameter marked with * is set on the NC side when FR-SF is bus-linked to M300 series CNC.

#	Parameter		Description	Setting range (unit)																																
43			Not used Set "0".																																	
44	CPI	Position control loop, K _p , K _i multiplication	<p>Valid when "1" is set for bit 8 #45 CWT.</p> <p>K_r/K_i multiplication which differs from that for oriented spindle stop is set for sync. tap and C-axis control.</p> <p>K_p/K_i multiplication can be set within range from 1/16 to 15 (folds)(x₁ = 10_H(16_D)).</p> <table border="1" data-bbox="743 764 1182 842"> <tr> <td>F</td><td>E</td><td>D</td><td>C</td><td>B</td><td>A</td><td>9</td><td>8</td><td>7</td><td>6</td><td>5</td><td>4</td><td>3</td><td>2</td><td>1</td><td>0</td> </tr> <tr> <td colspan="8">K_i multiplication for position control loop</td> <td colspan="8">K_p multiplication for position control loop</td> </tr> </table> <p>With larger multiplication, response to impact load becomes faster, but gearing sound becomes larger.</p> <p>It is recommended to be set within range from x₁ to x₂ (1010_H - 2020_H).</p> <p>Usually same multiplication is applied to K_p and K_i.</p>	F	E	D	C	B	A	9	8	7	6	5	4	3	2	1	0	K _i multiplication for position control loop								K _p multiplication for position control loop								<p>Hexadecimal notation</p> <p>Setting example: To set K_p and K_i to x1.5, CPU = $\frac{18}{K_i} \frac{18H}{K_p}$</p>
F	E	D	C	B	A	9	8	7	6	5	4	3	2	1	0																					
K _i multiplication for position control loop								K _p multiplication for position control loop																												

#	Parameter	Description	Setting range (unit)																																																																			
45	CWT	<p>Kp, K₁, ω, setting for position loop control</p> <p>Valid/invalid</p>	<div style="text-align: center;"> <table border="1" style="margin: auto;"> <tr> <td>F</td><td>E</td><td>D</td><td>C</td><td>B</td><td>A</td><td>9</td><td>8</td><td>7</td><td>6</td><td>5</td><td>4</td><td>3</td><td>2</td><td>1</td><td>0</td> </tr> <tr> <td colspan="11"></td> <td colspan="5" style="text-align: center;"> <i>Or selected (rad/n) for position control loop</i> </td> </tr> </table> </div> <p style="text-align: center;">5 bit combination</p> <table style="width: 100%; border-collapse: collapse;"> <tr> <td style="width: 50%; vertical-align: top;"> <p>For position control loop</p> <p>0 : Delay/advance</p> <p>1 : PI</p> <p>#44/#45 parameter setting, validity</p> <p>0: Invalid</p> <p>For K_p, K₁ and ω, values set by #2F ORS1 are selected.</p> <p>1: Valid</p> <p>For K_p, K₁ and ω, values set by #44/#45 are selected.</p> </td> <td style="width: 50%; vertical-align: top;"> <table style="width: 100%; border-collapse: collapse;"> <tr><td>0:0.55</td><td>10:9.4</td></tr> <tr><td>1:1.1</td><td>11:10.0</td></tr> <tr><td>2:1.65</td><td>12:10.55</td></tr> <tr><td>3:2.2</td><td>13:11.10</td></tr> <tr><td>4:2.75</td><td>14:11.65</td></tr> <tr><td>5:3.3</td><td>15:12.2</td></tr> <tr><td>6:3.85</td><td>16:12.8</td></tr> <tr><td>7:4.4</td><td>17:13.35</td></tr> <tr><td>8:4.95</td><td>18:13.9</td></tr> <tr><td>9:5.5</td><td>19:14.45</td></tr> <tr><td>A:6.05</td><td>1A:15.05</td></tr> <tr><td>B:6.6</td><td>1B:15.6</td></tr> <tr><td>C:7.15</td><td>1C:16.15</td></tr> <tr><td>D:7.7</td><td>1D:16.75</td></tr> <tr><td>E:8.25</td><td>1E:17.3</td></tr> <tr><td>F:8.85</td><td>1F:17.85</td></tr> </table> </td> </tr> </table>	F	E	D	C	B	A	9	8	7	6	5	4	3	2	1	0												<i>Or selected (rad/n) for position control loop</i>					<p>For position control loop</p> <p>0 : Delay/advance</p> <p>1 : PI</p> <p>#44/#45 parameter setting, validity</p> <p>0: Invalid</p> <p>For K_p, K₁ and ω, values set by #2F ORS1 are selected.</p> <p>1: Valid</p> <p>For K_p, K₁ and ω, values set by #44/#45 are selected.</p>	<table style="width: 100%; border-collapse: collapse;"> <tr><td>0:0.55</td><td>10:9.4</td></tr> <tr><td>1:1.1</td><td>11:10.0</td></tr> <tr><td>2:1.65</td><td>12:10.55</td></tr> <tr><td>3:2.2</td><td>13:11.10</td></tr> <tr><td>4:2.75</td><td>14:11.65</td></tr> <tr><td>5:3.3</td><td>15:12.2</td></tr> <tr><td>6:3.85</td><td>16:12.8</td></tr> <tr><td>7:4.4</td><td>17:13.35</td></tr> <tr><td>8:4.95</td><td>18:13.9</td></tr> <tr><td>9:5.5</td><td>19:14.45</td></tr> <tr><td>A:6.05</td><td>1A:15.05</td></tr> <tr><td>B:6.6</td><td>1B:15.6</td></tr> <tr><td>C:7.15</td><td>1C:16.15</td></tr> <tr><td>D:7.7</td><td>1D:16.75</td></tr> <tr><td>E:8.25</td><td>1E:17.3</td></tr> <tr><td>F:8.85</td><td>1F:17.85</td></tr> </table>	0:0.55	10:9.4	1:1.1	11:10.0	2:1.65	12:10.55	3:2.2	13:11.10	4:2.75	14:11.65	5:3.3	15:12.2	6:3.85	16:12.8	7:4.4	17:13.35	8:4.95	18:13.9	9:5.5	19:14.45	A:6.05	1A:15.05	B:6.6	1B:15.6	C:7.15	1C:16.15	D:7.7	1D:16.75	E:8.25	1E:17.3	F:8.85	1F:17.85	Hexadecimal notation
F	E	D	C	B	A	9	8	7	6	5	4	3	2	1	0																																																							
											<i>Or selected (rad/n) for position control loop</i>																																																											
<p>For position control loop</p> <p>0 : Delay/advance</p> <p>1 : PI</p> <p>#44/#45 parameter setting, validity</p> <p>0: Invalid</p> <p>For K_p, K₁ and ω, values set by #2F ORS1 are selected.</p> <p>1: Valid</p> <p>For K_p, K₁ and ω, values set by #44/#45 are selected.</p>	<table style="width: 100%; border-collapse: collapse;"> <tr><td>0:0.55</td><td>10:9.4</td></tr> <tr><td>1:1.1</td><td>11:10.0</td></tr> <tr><td>2:1.65</td><td>12:10.55</td></tr> <tr><td>3:2.2</td><td>13:11.10</td></tr> <tr><td>4:2.75</td><td>14:11.65</td></tr> <tr><td>5:3.3</td><td>15:12.2</td></tr> <tr><td>6:3.85</td><td>16:12.8</td></tr> <tr><td>7:4.4</td><td>17:13.35</td></tr> <tr><td>8:4.95</td><td>18:13.9</td></tr> <tr><td>9:5.5</td><td>19:14.45</td></tr> <tr><td>A:6.05</td><td>1A:15.05</td></tr> <tr><td>B:6.6</td><td>1B:15.6</td></tr> <tr><td>C:7.15</td><td>1C:16.15</td></tr> <tr><td>D:7.7</td><td>1D:16.75</td></tr> <tr><td>E:8.25</td><td>1E:17.3</td></tr> <tr><td>F:8.85</td><td>1F:17.85</td></tr> </table>	0:0.55	10:9.4	1:1.1	11:10.0	2:1.65	12:10.55	3:2.2	13:11.10	4:2.75	14:11.65	5:3.3	15:12.2	6:3.85	16:12.8	7:4.4	17:13.35	8:4.95	18:13.9	9:5.5	19:14.45	A:6.05	1A:15.05	B:6.6	1B:15.6	C:7.15	1C:16.15	D:7.7	1D:16.75	E:8.25	1E:17.3	F:8.85	1F:17.85																																					
0:0.55	10:9.4																																																																					
1:1.1	11:10.0																																																																					
2:1.65	12:10.55																																																																					
3:2.2	13:11.10																																																																					
4:2.75	14:11.65																																																																					
5:3.3	15:12.2																																																																					
6:3.85	16:12.8																																																																					
7:4.4	17:13.35																																																																					
8:4.95	18:13.9																																																																					
9:5.5	19:14.45																																																																					
A:6.05	1A:15.05																																																																					
B:6.6	1B:15.6																																																																					
C:7.15	1C:16.15																																																																					
D:7.7	1D:16.75																																																																					
E:8.25	1E:17.3																																																																					
F:8.85	1F:17.85																																																																					
46		Not used	Set "0".																																																																			
47		Not used	Set "0".																																																																			
48		Not used	Set "0".																																																																			

#	Parameter		Description	Setting range (unit)
49	GAH1	Auxiliary number of gear teeth on spindle side	If number of teeth on spindle side is out of normal setting range of gear teeth parameter (GRA1 - 4, GR1 - 4), it is set with this parameter.	1 - 7FFF (hexadecimal notation)
4A	GAH2			
4B	GAH3			
4C	GAH4			
4D	GBH1			
4E	GBH2	Auxiliary number of gear teeth on motor side	<p>Number of gear teeth = X x Y</p> <p>where, X: Normal number of gear teeth</p> <p>Y: Auxiliary number of gear teeth</p> <p>"Auxiliary number of gear teeth" is set for semi-closed loop system where accurate gear ratio must be set.</p> <p>In the case of full-closed loop system, approximate number of gear teeth is set for X, and "0" is set for Y.</p> <p>Parameters GAH1 - GAH4 and GBH1 - GBH4 correspond to GRA1 - GRA4, and GRB1 - GRB4 respectively.</p>	
4F	GBH3			
50	GBH4			
59	SVSP	Servo shift speed	<p>Spindle speed at which control loop mode is changed from speed loop to position mode is set.</p> <p>Standard setting: 40</p>	10 - 200(rpm)

#	Parameter		Description	Setting range (unit)	
5A	PDT	Home return deceleration point	Point at which speed is decelerated to stop for home return is set. If overrun occurs at stop of motor, setting should be increased. Standard setting: 88	1 - 2000 (pulses)	
5B	IPOS	Position loop in-position range	Range within which "in-position" signal is output in positioning control is set. Standard setting: Tap ... 10 C axis 3E8	Hexadecimal notation	
5C	PZSF L	Position loop zero return shift (low byte)	Amount of shift of zero return position from Z phase, when loop mode is changed from speed loop to position loop is set.	Tapperless	C axis
5D	DZSP H	Position loop zero return shift (high byte)		0 - FFF	57E40
5E	DCSN	Dual cushion	This is set to apply cushion to speed change. 0: Invalid 1: Valid It is set to surpress gear sound. Standard setting: 1	Decimal notation	
5F	PYX	Excitation ratio	Excitation ratio is set. To reduce gear sound, setting is decreased. To enhance impact load response, setting is increased. Standard setting: 0 0:50% 1:25% 2:75% 3:100%		

#	Parameter	Description	Setting range (unit)					
C1 C2	OM1	PG1 multiplication for each gear	<p>Multiplication of #21 PG1 (1st deceleration point) can be set for each gear.</p> <p style="text-align: center;">F 8 7 0</p> <p>C1 <table border="1" style="display: inline-table; vertical-align: middle;"><tr><td style="width: 50px;">Gear 01</td><td style="width: 50px;">Gear 00</td></tr></table></p> <p style="text-align: center;">F 8 7 0</p> <p>C2 <table border="1" style="display: inline-table; vertical-align: middle;"><tr><td style="width: 50px;">Gear 11</td><td style="width: 50px;">Gear 10</td></tr></table></p> <p>10_H (16_D) is for 1 fold.</p> <p>When deceleration point in oriented spindle stop operation must be changed, this parameter is set.</p> <p>When "0" is set, multiplication is one fold.</p>	Gear 01	Gear 00	Gear 11	Gear 10	1/16 - 15 times (x16)
Gear 01	Gear 00							
Gear 11	Gear 10							
C3 C4	OM2	PG2 multiplication for each gear	<p>Multiplication of #22 PG2 (2nd deceleration point) can be set for each gear.</p> <p style="text-align: center;">F 8 7 0</p> <p>C3 <table border="1" style="display: inline-table; vertical-align: middle;"><tr><td style="width: 50px;">Gear 01</td><td style="width: 50px;">Gear 00</td></tr></table></p> <p style="text-align: center;">F 8 7 0</p> <p>C4 <table border="1" style="display: inline-table; vertical-align: middle;"><tr><td style="width: 50px;">Gear 11</td><td style="width: 50px;">Gear 10</td></tr></table></p> <p>10_H (16_D) is for 1 fold.</p> <p>When deceleration point in oriented spindle stop operation must be changed, this parameter is set.</p> <p>When "0" is set, multiplication is one fold.</p>	Gear 01	Gear 00	Gear 11	Gear 10	1/16 - 15 times (x16)
Gear 01	Gear 00							
Gear 11	Gear 10							

APPENDIX 2 Motor parameter list

DATA No.	Motor type	Motor max. speed
0	917 F 435 1500/6000/10000 1.5/2.2kw	6000
1	925 F 435 1500/6000/10000 2.2/3.7kw	6000
2	936 F 444 1500/4500/8000 3.7/5.5kw	6000
3	957 F 419 1500/4500/8000 5.5/7.5kw	6000
4	957 F 426 1500/4500/8000 5.5/9.0kw	6000
5	977 F 404 1500/4500/6000 7.5/11.0kw	6000
6	013 F 429 1500/4500/6000 11.0/15.0kw	6000
7	017 F 408 1500/4500/6000 15.0/18.5kw	6000
8	017 F 408 1500/4500/6000 18.5/22.0kw	6000
9	019 F 445 1500/4500 22.0/26.0kw	6000
10	026 F 405 1500/4500 22.0/30.0kw	6000
11		
12		
13		
14		
15		
16	Same as No. 0 1.5/2.2kw	10000
17	No. 1 2.2/3.7kw	10000
18	No. 2 3.7/5.5kw	10000
19	No. 3 5.5/7.5kw	10000
20	No. 4 5.5/9.0kw	10000
21	No. 5 7.5/11.0kw	10000
22	No. 6 11.0/15.0kw	10000
23	No. 7 15.0/18.5kw	10000
24	No. 8 18.5/22.0kw	10000
25	No. 9 22.0/26.0kw	10000
26	No. 10 22.0/30.0kw	10000
27		
28		
29		
30		
31		

DATA No.	Motor type	Motor max. speed
32	1.5/2.2kw	6000
33	925 F 438 1150/3450/8000 2.2/3.7kw	6000
34	936 F 443 1150/3450/8000 3.7/5.5kw	6000
35	957 F 434 1150/3450/6000 5.5/7.5kw	6000
36		
37	977 F 403 1150/3450/6000 7.5/11.0kw	6000
38	013 F 431 1150/3450/6000 11.0/15.0kw	6000
39	017 F 405 1150/3450/4600 15.0/18.5kw	6000
40	019 F 442 1150/3450/4600 18.5/22.0kw	6000
41	023 F 474 1150/3450/4600 22.0/26.0kw	6000
42	026 F 406 1150/3450/4600 22.0/30.0kw	6000
43	031 F 420 1150/3450/4600 30.0/37.0kw	6000
44	038 F 424 1150/3450/4600 37.0/45.0kw	6000
45		
46		
47		
48		
49	Same as No. 33 2.2/3.7kw	10000
50	No. 34 3.7/5.5kw	10000
51	No. 35 5.5/7.5kw	10000
52		
53	Same as No. 37 7.5/11.0kw	10000
54	No. 38 11.0/15.0kw	10000
55	No. 39 15.0/18.5kw	10000
56	No. 40 18.5/22.0kw	10000
57	No. 41 22.0/26.0kw	10000
58	No. 42 22.0/30.0kw	10000
59	No. 43 30.0/37.0kw	10000
60	No. 44 37.0/45.0kw	10000
61		
62		
63		

Note: For motor having maximum speed ranging from 600rpm to 1000rpm, use motor constant of 1000rpm for maximum speed.

3.5.2 Parameter setting

When [SPINDLE PARAMETER] of MACHINE PARAMETER screen is selected, parameters are displayed.

There are two groups of spindle parameters; one is those used on NC side, and the other is those sent to FR-SF when FR-SF is bus-linked with NC.

- (1) Parameters used on NC side

[SPINDLE SPEC.]				M-PARAM 7. 1/ 2	
#					
1	slimt 1	0	13	stap 1	527
2	2	790	14	2	2640
3	3	4000	15	3	
4	4	0	16	4	
5	smax1	0	17	smini	1
6	2	790	18		
7	3	4000	19		
8	4	0	20		
9	ssift 1	0	21	sori	0
10	2	0	22	sgear	0
11	3	0	23		
12	4	0	24		
#(<input type="checkbox"/>) DATA()					
MC-ERR		MACRO		<input checked="" type="checkbox"/> SPINDLE	
				PLC	
				MENU	

Spindle parameter list (1/2)

#	Parameter		Description	Setting range (unit)
1	slimt 1	Speed limit	For GEAR 00 } spindle speed GEAR 01 } with motor at GEAR 10 } maximum speed GEAR 11 } is set.	0 - 99999(rpm)
2	2			
3	3			
4	4			
5	smax 1	Max. speed	For GEAR 00 } maximum spindle GEAR 01 } speed is set. GEAR 10 } Slimt ≥ Smax GEAR 11 }	
6	2			
7	3			
8	4			
9	ssift 1	Shift speed	For GEAR 00 } spindle speed GEAR 01 } for gear shift GEAR 10 } is set. GEAR 11 }	0 - 32767(rpm)
10	2			
11	3			
12	4			
13	stap 1	Tap speed	For GEAR 00 } maximum spindle GEAR 01 } speed during GEAR 10 } tap cycle is GEAR 11 } set.	0 - 99999(rpm)
14	2			
15	3			
16	4			

#	Parameter		Description	Setting range (unit)
17	smini	Min. speed	Minimum spindle speed is set. Spindle runs at this speed even when speed specified by S command is lower than this speed.	0 - 32767(rpm)
21	sori			
22	sgear	Encoder gear ratio	Gear ratio between spindle gear and encoder gear is set	0:1/1 1:1/2 2:1/4 3:1/8

(2) Parameters sent to FR-SF

These parameters are sent from NC to FR-SF when FR-SF is bus-linked with NC.

Although FR-SF has its own parameters, parameters shown by NC display becomes valid when FR-SF is bus-linked with NC.

(SPINDLE SPEC.)				M-PARAM 7. 2/ 2			
#							
1	PG1	133	13		25	GRA1	100
2	PG2	20	14		26	2	100
3	PGC	10.00	15	ORS1	6601	27	3 100
4	ZRZ	1.00	16	ORS2	0	28	4 100
5	OSP	220	17	TSP	4500	29	GRB1 100
6	CSP	20	18	ZSP	50	30	2 100
7	PST	2048	19	CSN	300	31	3 100
8	BRC	0	20	SDT	10	32	4 100
9			21	TLM	10	33	
10			22	VKP	63	34	
11			23	VKI	60	35	
12			24	TYP	0	36	

#() DATA ()

MC-ERR | MACRO | SPINDLE | PLC | MENU

Note: Parameter set

on the NC display can be made invalid by setting switch SW5-1 of card SF-CA to "ON". In this case, parameters set by FR-SF becomes valid.

Spindle parameter list (2/2)

#	Parameter		Description	Setting range (unit)	
				Encoder	Magnesen-sor
1	PG1	Spindle orientation, 1st decel. point	Encorder spindle orientation	0 - 359 (deg.)	0 - 500ms
			Spindle rotational angle at which creep speed starts is set.		
			Magnesensor spindle orientation	0 - 359 (deg.)	0 - 500ms
			Time in which creep speed starts after passing through linear zone is set.		
			Standard setting		
			<u>Encoder</u> 180		
			<u>Magnesensor</u> 133		
2	PG2	Spindle orientation, 2nd decel. point	Angle at which creep speed run changes to position control loop is set.		0 - 40 (deg.)
			Standard setting: 20		

#	Parameter		Description	Setting range (unit)	
3	PGC	Sync. tap, C-axis control position loop gain	Spindle position loop gain during sync. tap C-axis control is set. Standard setting: 10.00	0.01 - 999.99 (rad/s)	
4	ZRZ	Spindle orientation, in-position range	Error range within which spindle orientation complete signal is output is set. Standard setting: 1.00	Encoder	Magne-sensor
				0 - 359 (deg.)	0 - 39 (deg.)
5	OSP	Spindle orientation speed	Spindle orientation speed is set. Standard setting: 2.20	0 - 1000(rpm)	
6	CSP	Creep speed	Creep speed is set. Standard setting: 20	0 - 1000(rpm)	
7	RST	Position shift	Oriented spindle stop position is set. Encoder: Stop position is set within 360 deg. with increment of 360/4096. Magne-sensor: Stop position is set within range from -5 deg. to +5 deg. with increment of 10/1024 (2040 for 0 deg.). Standard setting: 2048	Encoder	Magne-sensor
				0 - 4095 (pulses)	1536 - 2560
8	BRC		Not used Set to "0".		
15	ORS1	Oriented spindle stop control 1	For details of setting, refer to #15.	Set in hexadecimal notation. 0 - FFFF	
16	ORS2	Oriented spindle stop control 2	For details of setting, refer to #16.		

#	Parameter		Description	Setting range (unit)
17	TSP	Maximum motor speed	Maximum speed of motor is set.	0 - 32760(rpm)
18	ZSP	Motor zero speed	Speed at which "zero speed" signal is output is set. Standard setting: 50	0 - 1000(rpm)
19	CSN	Accel./decel. time constant	Time taken for acceleration from 0 to maximum speed (or deceleration from maximum speed to zero) is set (this setting is ignored when position loop is used). Standard setting: 300	0 - 32760(msec)
20	SDT	Speed detection ratio	Speed at which "speed detect" signal is output is set in terms of percentage to motor maximum speed. Standard setting: 10	0 - 100(%)
21	TLM	Torque limit	Torque limit is set in terms of percentage for torque limit signal TL2. Standard setting: 10	0 - 120(%)
22	VKP	Speed loop proportional gain	Proportional gain is set for speed control loop. The larger the setting (100 - 150), the faster is the response, but the larger is the noise and vibration. Standard setting: 63	0 - 1000(rad/s)
23	VKI	Speed loop integral gain	Integral gain is set for speed control loop. It should be set so that its ratio to proportional gain VKP	0 - 1000 (1/10rad/s)

#	Parameter		Description	Setting range (unit)
			is almost constant. Standard setting: 60	
25	GRA1	Number of gear teeth on spindle side	Number of gear teeth for gear 00 on spindle side is set.	Gear ratio is set with gear teeth on spindle side, and gear teeth on motor side Spindle speed x $\frac{\text{Spindle side gear teeth (GRA1 - 4)}}{\text{Motor side gear teeth (GRB1 - 4)}}$ = Motor speed
26	GRA2		Number of gear teeth for gear 01 on spindle side is set.	
27	GRA3		Number of gear teeth for gear 10 on spindle side is set.	
28	GRA4		Number of gear teeth for gear 11 on spindle side is set.	
29	GRB1	Number of gear teeth on motor side	Number of gear teeth for gear 00 on motor side is set.	
30	GRB2		Number of gear teeth for gear 01 on motor side is set.	
31	GRB3		Number of gear teeth for gear 10 on motor side is set.	
32	GRB4		Number of gear teeth for gear 11 on motor side is set.	

No.	Parameter	Description	Setting range (unit)																																																																																																																																																																																																																																																																																																																																	
15	ORS1 Oriented spindle stop control 1	<table border="1" style="width: 100%; border-collapse: collapse;"> <tr> <td style="width: 4%;">F</td><td style="width: 4%;">E</td><td style="width: 4%;">D</td><td style="width: 4%;">C</td> <td style="width: 4%;">B</td><td style="width: 4%;">A</td><td style="width: 4%;">9</td><td style="width: 4%;">8</td> <td style="width: 4%;">7</td><td style="width: 4%;">6</td><td style="width: 4%;">5</td><td style="width: 4%;">4</td> <td style="width: 4%;">3</td><td style="width: 4%;">2</td><td style="width: 4%;">1</td><td style="width: 4%;">0</td> </tr> <tr> <td colspan="4">Spindle orient, K_i magnif.</td> <td colspan="4">Spindle orient, K_r magnif.</td> <td colspan="4"></td> <td style="writing-mode: vertical-rl; transform: rotate(180deg);">Servo lock control</td> <td colspan="4">ω_r select [rad/s]</td> </tr> <tr> <td colspan="4" style="text-align: center;">└───┬───┬───┬───┘</td> <td colspan="4" style="text-align: center;">└───┬───┬───┬───┘</td> <td colspan="4" style="text-align: center;">└───┬───┬───┬───┘</td> <td colspan="4" style="text-align: center;">└───┬───┬───┬───┘</td> </tr> <tr> <td colspan="4" style="text-align: center;">4-bit combination</td> <td colspan="4" style="text-align: center;">4-bit combination</td> <td colspan="4" style="text-align: center;">4-bit combination</td> <td colspan="4" style="text-align: center;">4-bit combination</td> </tr> <tr> <td colspan="4">0 : 0.6 (folds)</td> <td colspan="4">0 : 0.6 (folds)</td> <td colspan="4">0 : Delay/advance</td> <td colspan="4">0 : 0.55 [rad/s]</td> </tr> <tr> <td colspan="4">1 : 0.7</td> <td colspan="4">1 : 0.7</td> <td colspan="4">1 : P I</td> <td colspan="4">1 : 0.1</td> </tr> <tr> <td colspan="4">2 : 0.8</td> <td colspan="4">2 : 0.8</td> <td colspan="4"></td> <td colspan="4">2 : 1.65</td> </tr> <tr> <td colspan="4">3 : 0.9</td> <td colspan="4">3 : 0.9</td> <td colspan="4"></td> <td colspan="4">3 : 2.2</td> </tr> <tr> <td colspan="4">4 : 1</td> <td colspan="4">4 : 1</td> <td colspan="4"></td> <td colspan="4">4 : 2.75</td> </tr> <tr> <td colspan="4">5 : 1.2</td> <td colspan="4">5 : 1.2</td> <td colspan="4"></td> <td colspan="4">5 : 3.3</td> </tr> <tr> <td colspan="4">6 : 1.4</td> <td colspan="4">6 : 1.4</td> <td colspan="4"></td> <td colspan="4">6 : 3.85</td> </tr> <tr> <td colspan="4">7 : 1.6</td> <td colspan="4">7 : 1.6</td> <td colspan="4"></td> <td colspan="4">7 : 4.4</td> </tr> <tr> <td colspan="4">8 : 1.8</td> <td colspan="4">8 : 1.8</td> <td colspan="4"></td> <td colspan="4">8 : 4.95</td> </tr> <tr> <td colspan="4">9 : 2</td> <td colspan="4">9 : 2</td> <td colspan="4"></td> <td colspan="4">9 : 5.5</td> </tr> <tr> <td colspan="4">A : 2.2</td> <td colspan="4">A : 2.2</td> <td colspan="4"></td> <td colspan="4">A : 6.05</td> </tr> <tr> <td colspan="4">B : 2.4</td> <td colspan="4">B : 2.4</td> <td colspan="4"></td> <td colspan="4">B : 6.6</td> </tr> <tr> <td colspan="4">C : 2.6</td> <td colspan="4">C : 2.6</td> <td colspan="4"></td> <td colspan="4">C : 7.15</td> </tr> <tr> <td colspan="4">D : 2.8</td> <td colspan="4">D : 2.8</td> <td colspan="4"></td> <td colspan="4">D : 7.7</td> </tr> <tr> <td colspan="4">E : 3</td> <td colspan="4">E : 3</td> <td colspan="4"></td> <td colspan="4">E : 8.25</td> </tr> <tr> <td colspan="4">F : 3.2</td> <td colspan="4">F : 3.2</td> <td colspan="4"></td> <td colspan="4">F : 8.8</td> </tr> </table> <p style="text-align: right; margin-top: 10px;">Standard setting: 7701</p>	F	E	D	C	B	A	9	8	7	6	5	4	3	2	1	0	Spindle orient, K _i magnif.				Spindle orient, K _r magnif.								Servo lock control	ω _r select [rad/s]				└───┬───┬───┬───┘				└───┬───┬───┬───┘				└───┬───┬───┬───┘				└───┬───┬───┬───┘				4-bit combination				4-bit combination				4-bit combination				4-bit combination				0 : 0.6 (folds)				0 : 0.6 (folds)				0 : Delay/advance				0 : 0.55 [rad/s]				1 : 0.7				1 : 0.7				1 : P I				1 : 0.1				2 : 0.8				2 : 0.8								2 : 1.65				3 : 0.9				3 : 0.9								3 : 2.2				4 : 1				4 : 1								4 : 2.75				5 : 1.2				5 : 1.2								5 : 3.3				6 : 1.4				6 : 1.4								6 : 3.85				7 : 1.6				7 : 1.6								7 : 4.4				8 : 1.8				8 : 1.8								8 : 4.95				9 : 2				9 : 2								9 : 5.5				A : 2.2				A : 2.2								A : 6.05				B : 2.4				B : 2.4								B : 6.6				C : 2.6				C : 2.6								C : 7.15				D : 2.8				D : 2.8								D : 7.7				E : 3				E : 3								E : 8.25				F : 3.2				F : 3.2								F : 8.8				Hexadecimal notation
F	E	D	C	B	A	9	8	7	6	5	4	3	2	1	0																																																																																																																																																																																																																																																																																																																					
Spindle orient, K _i magnif.				Spindle orient, K _r magnif.								Servo lock control	ω _r select [rad/s]																																																																																																																																																																																																																																																																																																																							
└───┬───┬───┬───┘				└───┬───┬───┬───┘				└───┬───┬───┬───┘				└───┬───┬───┬───┘																																																																																																																																																																																																																																																																																																																								
4-bit combination				4-bit combination				4-bit combination				4-bit combination																																																																																																																																																																																																																																																																																																																								
0 : 0.6 (folds)				0 : 0.6 (folds)				0 : Delay/advance				0 : 0.55 [rad/s]																																																																																																																																																																																																																																																																																																																								
1 : 0.7				1 : 0.7				1 : P I				1 : 0.1																																																																																																																																																																																																																																																																																																																								
2 : 0.8				2 : 0.8								2 : 1.65																																																																																																																																																																																																																																																																																																																								
3 : 0.9				3 : 0.9								3 : 2.2																																																																																																																																																																																																																																																																																																																								
4 : 1				4 : 1								4 : 2.75																																																																																																																																																																																																																																																																																																																								
5 : 1.2				5 : 1.2								5 : 3.3																																																																																																																																																																																																																																																																																																																								
6 : 1.4				6 : 1.4								6 : 3.85																																																																																																																																																																																																																																																																																																																								
7 : 1.6				7 : 1.6								7 : 4.4																																																																																																																																																																																																																																																																																																																								
8 : 1.8				8 : 1.8								8 : 4.95																																																																																																																																																																																																																																																																																																																								
9 : 2				9 : 2								9 : 5.5																																																																																																																																																																																																																																																																																																																								
A : 2.2				A : 2.2								A : 6.05																																																																																																																																																																																																																																																																																																																								
B : 2.4				B : 2.4								B : 6.6																																																																																																																																																																																																																																																																																																																								
C : 2.6				C : 2.6								C : 7.15																																																																																																																																																																																																																																																																																																																								
D : 2.8				D : 2.8								D : 7.7																																																																																																																																																																																																																																																																																																																								
E : 3				E : 3								E : 8.25																																																																																																																																																																																																																																																																																																																								
F : 3.2				F : 3.2								F : 8.8																																																																																																																																																																																																																																																																																																																								

No.	Parameter	Description	Setting range (unit)																																
16	ORS2 Oriented spindle stop control 2	<table border="1" style="width: 100%; border-collapse: collapse; text-align: center;"> <tr> <td style="width: 5%;">F</td><td style="width: 5%;">E</td><td style="width: 5%;">D</td><td style="width: 5%;">C</td><td style="width: 5%;">B</td><td style="width: 5%;">A</td><td style="width: 5%;">9</td><td style="width: 5%;">8</td><td style="width: 5%;">7</td><td style="width: 5%;">6</td><td style="width: 5%;">5</td><td style="width: 5%;">4</td><td style="width: 5%;">3</td><td style="width: 5%;">2</td><td style="width: 5%;">1</td><td style="width: 5%;">0</td> </tr> <tr> <td style="font-size: 8px;">Zero return direction, position zero</td><td style="font-size: 8px;">Detector direction, position zero</td><td></td><td></td><td style="font-size: 8px;">Reverse rotation, position zero</td><td style="font-size: 8px;">Clockwise/anti-clockwise, position zero</td><td style="font-size: 8px;">MTR rotation command, position zero</td><td style="font-size: 8px;">Detector direction, vibration</td><td></td><td></td><td></td><td></td><td></td><td></td><td style="font-size: 8px;">Direction of rotation, spindle orientation</td><td></td> </tr> </table> <p style="margin-left: 100px;"> 0: (+) direction 2-bit combination 1: (-) direction 0: PRE 0: (+) direction 1: CW 1: (-) direction 2: CCW 3: Prohibited </p> <p style="margin-left: 100px;"> 0: Closed 1: Semi-closed </p> <p style="margin-left: 100px;"> 0: Faint excitation 1: Intense excitation </p> <p style="margin-left: 100px;"> 0: (+) direction 1: (-) direction </p> <p style="margin-left: 100px;"> 0: (+) direction 1: (-) direction </p> <p style="margin-left: 100px;"> Normally PRE is set. </p> <p style="margin-left: 100px;"> PRE Same as previous direction </p> <p style="text-align: right; margin-right: 50px;">Standard setting: 0</p>	F	E	D	C	B	A	9	8	7	6	5	4	3	2	1	0	Zero return direction, position zero	Detector direction, position zero			Reverse rotation, position zero	Clockwise/anti-clockwise, position zero	MTR rotation command, position zero	Detector direction, vibration							Direction of rotation, spindle orientation		Hexadecimal notation
F	E	D	C	B	A	9	8	7	6	5	4	3	2	1	0																				
Zero return direction, position zero	Detector direction, position zero			Reverse rotation, position zero	Clockwise/anti-clockwise, position zero	MTR rotation command, position zero	Detector direction, vibration							Direction of rotation, spindle orientation																					

[SPINDLE SPEC.]		M-PARAM 7. 2/ 2	
#			
1	PG1 133 13	25	GRA1 100
2	PG2 20 14	26	2 100
3	PGC 10.00 15 ORS1 6601	27	3 100
4	ZRZ 1.00 16 ORS2 0	28	4 100
5	OSP 220 17 TSP 4500	29	GRB1 100
6	CSP 20 18 ZSP 50	30	2 100
7	PST 2048 19 CSN 300	31	3 100
8	BRC 0 20 SDT 10	32	4 100
9		21	TLM 10 33
10		22	VKP 63 34
11		23	VKI 60 35
12		24	TYP 0 36
#() DATA ()			
MC-ERR	MACRO	SPINDLE	PLC MENU

#	Parameter	Description	Setting range (unit)
1	PG1	Magnesen-sor ori-ented spindle stop po-sition loop gain Position loop gain in magne-sensor spindle stop control is set. Standard setting: 100	0 - 360(0.1rad/s)
2	PG2	Encoder oriented spindle stop po-sition loop gain Position loop gain in encoder spindle stop control is set. Standard setting: 100	0 - 360(0.1rad/s)
3	OSP	Not used in high-speed oriented spindle stop.	0
4	CSP	Oriented spindle stop decelera-tion ratio Ratio of speed reduction after position loop starts is set. Standard setting: 30	0 - 1000

3.6 Adjustment

3.6.1 Adjustment to be made for accommodation to machine

(1) Setting the meters

Set the speed meter and the load meter as listed below (only when the meters are connected to terminals SM1 and LM1).

	Setting		Potentiometer
Speed meter	Set SW5-4 of card SF-CA to "ON" position.	Set VR4 so that speed meter reads the maximum speed.	VR4 of card SF-CA
Load meter		Set VR5 so that load meter reads 120%.	VR5 of card SF-CA

(2) Parameter setting pins

Check that pins have been set in accordance with the relevant list attached to the FR-SF.

For details of parameters for the FR-SF, refer to "Parameter list".

When the FR-SF is bus-linked to M300 series NC, some parameters are set through the NC CRT display.

Depending on FR-SF's specification, user should set number of gear teeth on the spindle side, and number of gear teeth on the motor side. ^(Note)

(3) Adjustment of oriented spindle stop position

Use parameter "PST" (FR-SF's parameter No. 27) to adjust oriented spindle stop position.

A) Encoder/motor built-in encoder spindle orientation

$$\text{Amount of position shift} = 360^\circ \times \frac{\text{Setting}}{4096}$$

B) Magnesensor spindle orientation

Zero degree (0°) position of magnesensor is assumed to be 2048 and angular range from -5° to +5° is divided by 1024.

Setting is possible within range from 1536 to 2560.

o If large hunting occurs at oriented spindle stop, position detector will be installed inversely.

In this case, reverse setting at bit 8 of parameter ORS2.

Note: Numbers of gear teeth on spindle side and motor side are as follows:

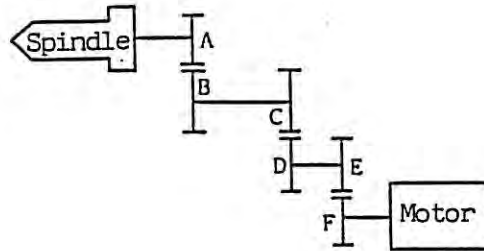

A ~ F: Number of gear teeth

Number of gear teeth on spindle side:

$$GRA = A \times C \times E$$

Number of gear teeth on motor side:

$$GRB = B \times D \times F$$

Correct gear ratio (or pulley ratio) should be assured for all gears in the drive system (from motor to spindle). Check that parameters GRA1 through GRB4 are set properly.

3.7 Trial operation

Tentatively run the motor under the normal load and check

- o if unusual sound occurs,
- o if foreign odor arises, and
- o measure bearing temperature.

3.8 Initial adjustment

3.8.1 Adjustment of magnesensor spindle orientation

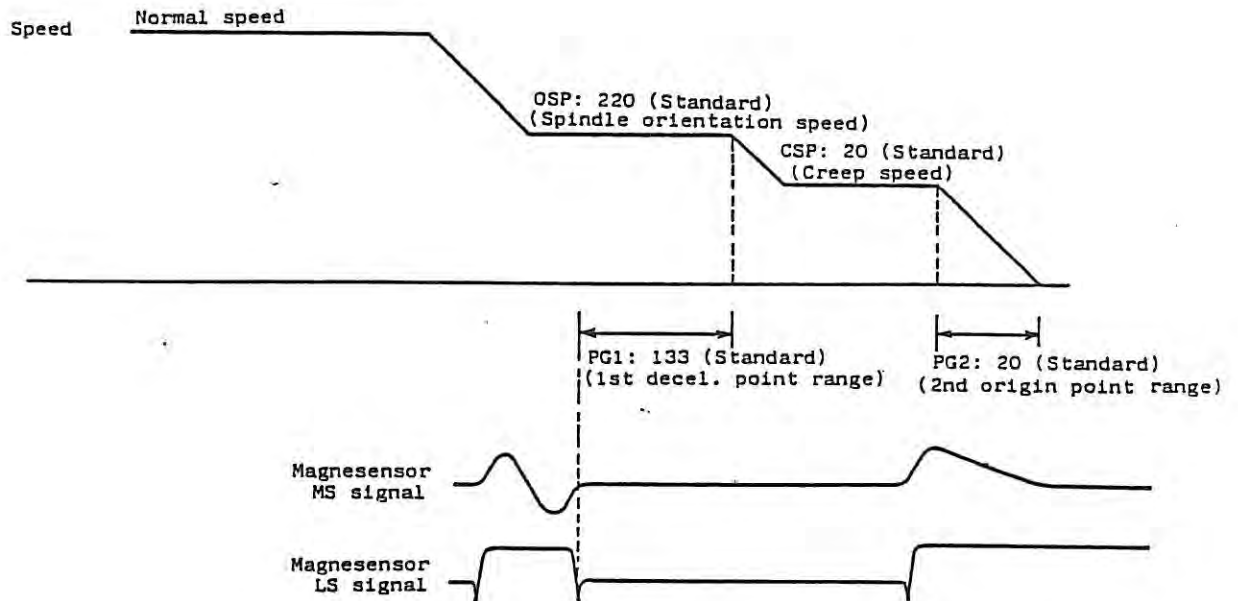

Set parameters properly, referring to the following table:

	Adjustment			
	OSP	CSP	PG1	PG2
Overrun at stop	↘	↘	↘	↗
Long orientation time	↗	→	↗	→
Hunting at stop	→	↘	→	↗

- Notes: 1. ↗ : Increase parameter setting.
 → : Keep parameter setting unchanged
 ↘ : Decrease parameter setting.
2. If large hunting occurs at oriented spindle stop, position detector will be installed inversely. In this case, reverse setting at bit 8 of parameter ORS2.

To determine the best value for parameter setting, perform the following procedure:

- 1) Decrease OSP setting to about 50rpm, and PGI setting to about 80, to prolong the time for which motion is at creep speed and try oriented spindle stop with the standard settings for CPS (i.e., 20rpm) and PG2 (i.e., 20) to check.
- 2) If overrun occurs at oriented spindle stop, increase PG2 setting (it may be increased up to 40).
If overrun occurs again after PG2 setting is increased, decrease CSP setting (it may be decreased up to 10).
If overrun occurs again after decrease of CSP setting, enhance "servo rigidity" (later described).
- 3) After CSP and PG2 settings have been determined (at steps 2) and 3)), set parameters OSP and PG1 to the standard values 220rpm and 133 respectively and try oriented spindle stop to check.
- 4) If overrun occurs at oriented spindle stop, decrease PG1 setting gradually until overrun no longer occurs. If overrun cannot be eliminated with low PG1 setting, decrease OSP setting.
- 5) In case, where time for which motion is at creep speed is long (hence, time for spindle orientation is excessive), increase PG1 and/or OSP settings, avoiding occurrence of overrun (maximum permissible settings are 300 for OSP, and 200 for PG1).

6) After completion of stop 5), check speed at each stage of gearing.

It is recommended to give priority in setting sequence to faster spindle speed, rather than slower speed, because overrun is more likely to occur with faster spindle speed.

3.8.2 Adjustment of encoder spindle orientation

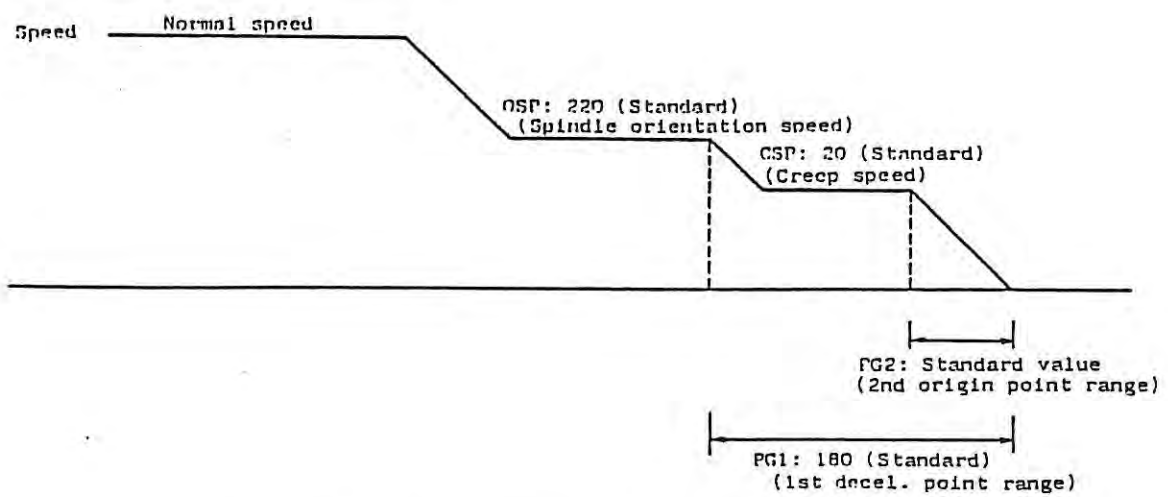

Set parameters properly, referring to the following table:

	Adjustment			
	OSP	CSP	PG1	PG2
Overrun at stop	↘	↘	↗	↗
long orientation time	↗	→	↘	→
Hunting at stop	→	↘	→	↗

Notes: 1. ↗ : Increase parameter setting.
 → : Keep parameter setting unchanged.
 ↘ : Decrease parameter setting.

2. If large hunting occurs at oriented spindle stop, position detector will be installed inversely. In this case, reverse setting at bit 8 of parameter ORS2.

To determine the best value for each parameter setting, perform the following procedure:

- 1) Decrease OSP setting to about 50rpm, and PG1 setting to about 80, to prolong the time for which motion is at creep speed and try oriented spindle stop with the standard settings for CPS (i.e., 20rpm) and PG2 (i.e., 20) to check.
- 2) If overrun occurs at oriented spindle stop, increase PG2 setting (it may be increased up to 40).
If overrun occurs again after PG2 setting is increased, decrease CSP setting (it may be decreased up to 10).
If overrun occurs again after decrease of CSP setting, enhance "servo rigidity" (later described).
- 3) After CSP and PG2 settings have been determined (at steps 2) and 3)), set parameters OSP and PG1 to the standard values, that is, 220rpm and 180 respectively, and try oriented spindle stop to check.
- 4) If overrun occurs at oriented spindle stop, decrease PG1 setting gradually until overrun no longer occurs. If overrun cannot be eliminated with low PG1 setting, decrease OSP setting.
- 5) In case, where time for which motion is at creep speed

is long (hence, time for spindle orientation is excessive), decrease PG1 setting or increase OSP, avoiding occurrence of overrun (maximum permissible setting for OSP is 300, and PG1 setting should be larger than PG2 setting).

- 6) After completion of step 5), check speed at each stage of gearing.

It is recommended to give priority in setting sequence to faster spindle speed, rather than slower speed, because overrun is more likely to occur with faster spindle speed.

3.8.3 Adjustment of servo rigidity

"Servo rigidity" at oriented spindle stop can be enhanced as follows:

- 1) Increase CSP setting to an extent where overrun does not occur or decrease PG2 setting (maximum permissible setting for CSP is about 30rpm for further adjustment, change PG2 setting).

- 2) By setting bit of parameter ORS1, increase two magnifications K_r and K_i proportionally (if K_r is set to 1.2, for example, K_i should be set to 1.2).

If intense vibration occurs at oriented spindle stop, however, these settings cannot be further increased.

- 3) ω_r of parameter ORS1 is "gain" for compensation.

Momentary servo rigidity can be increased by increasing this value. With increase of ω_r , however, torque for positioning decreases.

§4. CARD CHECK

4.1 Card SF-CA

Note: PIN7 and PIN8 differ depending on card group No. (G51 or G52).

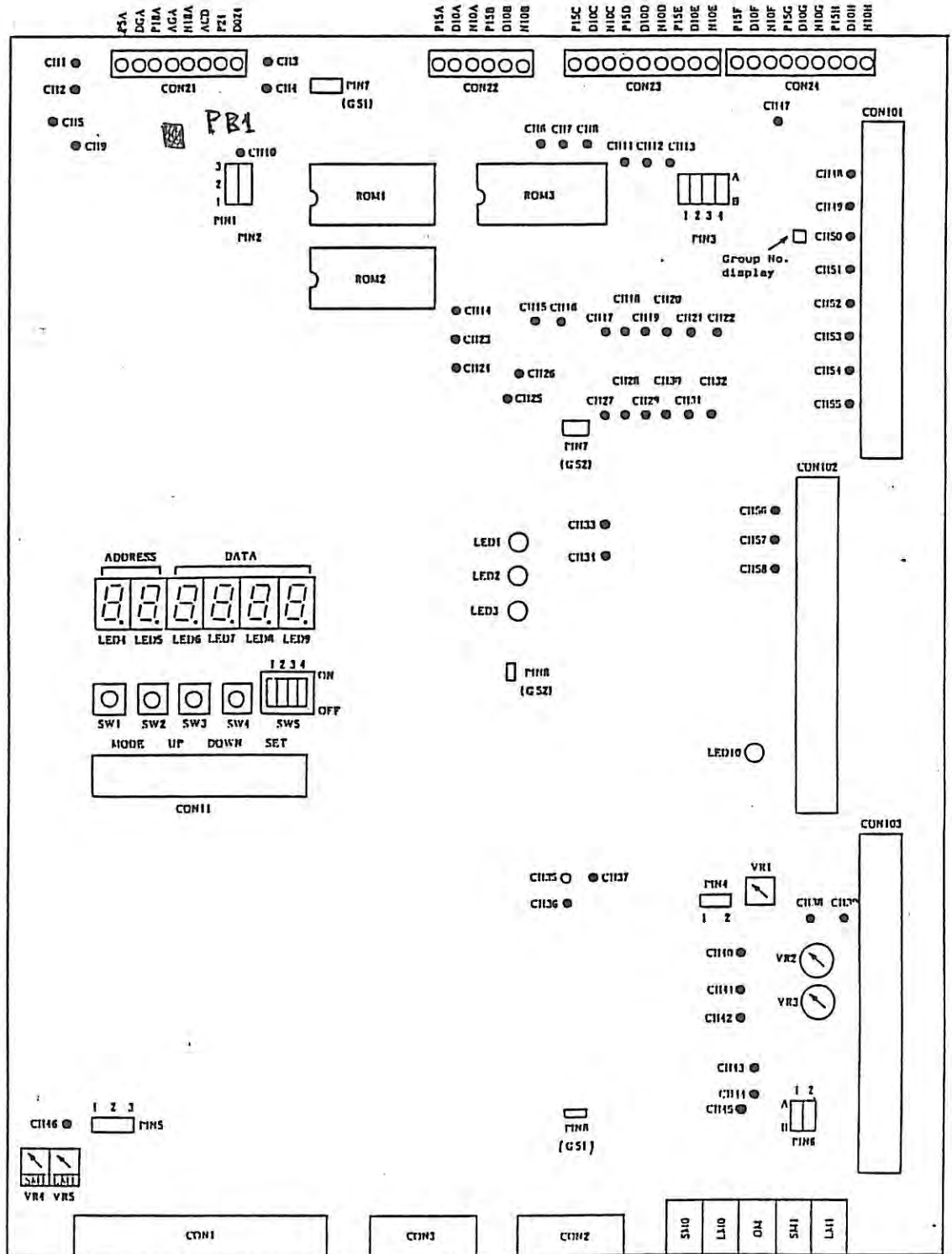

(1) DIP switch list

○: DIP switch set at ON
 x: DIP switch set at OFF









Switch No.	Name	Description																																				
SW5-1 to 3	TEST MODE selection	<p>TEST MODE is selected.</p> <table border="1"> <tr> <td>1</td> <td>2</td> <td>3</td> <td></td> </tr> <tr> <td>x</td> <td>x</td> <td>x</td> <td>..... Normal setting</td> </tr> <tr> <td>○</td> <td>x</td> <td>x</td> <td>..... NC parameters are ignored.</td> </tr> <tr> <td>x</td> <td>○</td> <td>x</td> <td>..... } FR-SF internally set parameters become valid.</td> </tr> <tr> <td>○</td> <td>○</td> <td>x</td> <td>..... } Test mode</td> </tr> <tr> <td>x</td> <td>x</td> <td>○</td> <td>..... } ○ Test aging</td> </tr> <tr> <td>○</td> <td>x</td> <td>○</td> <td>..... } ○ Parameter transfer</td> </tr> <tr> <td>x</td> <td>○</td> <td>○</td> <td>..... } ○ ROM initialization</td> </tr> <tr> <td>○</td> <td>○</td> <td>○</td> <td>..... }</td> </tr> </table>	1	2	3		x	x	x Normal setting	○	x	x NC parameters are ignored.	x	○	x } FR-SF internally set parameters become valid.	○	○	x } Test mode	x	x	○ } ○ Test aging	○	x	○ } ○ Parameter transfer	x	○	○ } ○ ROM initialization	○	○	○ }
1	2	3																																				
x	x	x Normal setting																																			
○	x	x NC parameters are ignored.																																			
x	○	x } FR-SF internally set parameters become valid.																																			
○	○	x } Test mode																																			
x	x	○ } ○ Test aging																																			
○	x	○ } ○ Parameter transfer																																			
x	○	○ } ○ ROM initialization																																			
○	○	○ }																																			
SW5-4	Meter calibration	<table border="1"> <tr> <td>4</td> <td></td> </tr> <tr> <td>○</td> <td>..... Meter full-scale output</td> </tr> <tr> <td>x</td> <td>..... Meter normal mode</td> </tr> </table> <p>For calibration of speed meter and load meter</p> <p>When SW5-4 is set at ON, meter full-scale voltage is output. Adjust potentiometer VR4 for calibration of speed meter, and VR5 for calibration of load meter.</p>	4		○ Meter full-scale output	x Meter normal mode																														
4																																						
○ Meter full-scale output																																					
x Meter normal mode																																					

(2) Pushbutton list

Switch No.	Name	Description
SW1	MODE	<p>LED display mode is selected.</p> <p>Each time the button is pressed, display mode changes in the following sequence:</p> <p>"STATUS" → "DIAGNOSIS" → "ALARM" → "PARAMETER(1)" "PARAMETER(8)" → "DEBUG"</p>
SW2	UP	<p>This button is pressed to scroll up display in each mode.</p> <p>In PARAMETER mode, parameter data is incremented when this button is pressed after</p>

Switch No.	Name	Description
		UP button is pressed.
SW3	DOWN	This button is pressed to scroll down display in each mode. In PARAMETER mode, parameter data is decremented when this button is pressed after DOWN button is pressed.
SW4	SET	This button is pressed to rewrite parameter. When SET button is pressed during PARAMETER mode, parameter data flickers. Then press UP and/or DOWN button to rewrite the data.
PB1		This button is pressed to reset CPU. After parameter is rewritten, press this button. Do not reset CPU while motor is running.

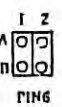
(3) Jumper pin list

Pin No.	Name	Setting	Description
PIN1 PIN2	Bus interface setting *For use of this function, parameter should be set. (#04MOD)		This setting is made when FR-SF is not bus-linked with M300 series CNC. Set parameter #04MOD to "0".
			This setting is made when FR-SF is bus-linked with M300 series CNC. Set parameter #04MOD to "2".
PIN3	Short-circuit prevention time setting		Time for which short-circuiting of transistors is prevented is set. Since improper setting may cause damage to equipment, make sure the setting meets the order specification table.
PIN4	Test pin for converter check		These test pins are used in the final test before shipment. Do not set pin.
PIN5	Analog speed reference signal selection *For use of this function, parameter should be set. (#05DSR)		For single-polarity signal input (0 to +10V) Set parameter #05DSR to "0".
			For double-polarity signal input (-10 to +10V) *When input offset must be adjusted finely, this setting is used. Set paam parameter #05DSR to "1".
PIN6	Test pin for control circuit check		These test pins are used in the final test before shipment. Alarm caused by controller over-heat is reset when 1A is connected to 1B. When 2A is connected to 2B, alarm caused by tripping of breaker is reset.
PIN7	Current loop gain select		For FR-SF capacity ranging from 5.5kW to 15kW

Pin No.	Name	Setting	Description
PIN7 (cont'd)		<input type="checkbox"/> PIN7	For FR-SF capacity larger than 18.5kW
PIN8			(Currently not used)

(4) LED list

LED No.	Description
LED1	Lights during regenerative energy is arising (converter).
LED2	Lights when inverter/converter base current is interrupted.
LED3	Watch dog alarm Lights after the power is turned on or after resetting. When FR-SF is bus-linked with M300 series CNC, the LED goes on lighting until initialization of NC is completed.
LED4 { LED9	Status display and alarm display
LED10	Lights during converter charging.

(5) Potentiometer list

VR No.	Description
VR1	Converter voltage gain adjustment (CH35)
VR2	U-phase current feedback zero adjustment (CH40)
VR3	V-phase current feedback zero adjustment (CH41)
VR4	Speed meter adjustment
VR5	Load meter adjustment

(6) Check terminal list

Terminal No.	Common	Description
CH1	DGA	+5V 4.88
CH2		0V, DGA (digital signal grounding)
CH3		0V, D024 (+24V grounding)
CH4	D024	+24V 23
CH5	AGA	+15V
CH6	AGA	U-phase voltage command
CH7	AGA	V-phase voltage command
CH8	AGA	W-phase voltage command
CH9		0V, AGA (analog signal grounding)
CH10	AGA	-15V
CH11	AGA	V-phase PWM waveform
CH12	AGA	W-phase PWM waveform
CH13	AGA	U-phase PWM waveform
CH14	AGA	V-phase standard sinusoidal waveform
CH15	AGA	W-phase standaard sinusoidal waveform
CH16	AGA	W-phase inverter current detection
CH17	AGA	U-phase base amplifier drive signal
CH18	AGA	V-phase base amplifier drive signal
CH19	AGA	W-phase base amplifier drive signal
CH20	AGA	\bar{U} -phase base amplifier drive signal
CH21	AGA	\bar{V} -phase base amplifier drive signal
CH22	AGA	\bar{W} -phase base amplifier drive signal
CH23	AGA	U-phase standard sinusoidal waveform
CH24	AGA	Triangle wave carrier
CH25	AGA	Current amplitude command
CH26	AGA	-10V standard voltage
CH27	AGA	R-phase base amplifier drive waveform
CH28	AGA	S-phase base amplifier drive waveform

Terminal No.	Common	Description
CH29	AGA	T-phase base amplifier drive waveform
CH30	AGA	\bar{R} -phase base amplifier drive waveform
CH31	AGA	\bar{S} -phase base amplifier drive waveform
CH32	AGA	\bar{T} -phase base amplifier drive waveform
CH33	DGA	Regenerative brake current control ... H level
CH34	AGA	Regenerative brake overcurrent L level
CH35	AGA	10V for 400V converter voltage
CH36	AGA	Supply voltage peak rectification
CH37	AGA	AD converter input (speed feedback and voltage reference signal detection)
CH38	AGA	+10V standard voltage
CH39	AGA	Regenerative converter current detect 10V at 200%
CH40	AGA	U-phase inverter current detect 2.5V at 100%
CH41	AGA	V-phase inverter current detect 2.5V at 100%
CH42	AGA	Converter DC current detect 10V at 200%
CH43	AGA	Inverter U, V, W-phase current full-wave rectification waveform 10V at 200%
CH44	AGA	Speed feedback, B-phase
CH45	AGA	Speed feedback, A-phase
CH46	AGA	Analog speed reference signal input
CH47	CON24-2	Inverter base amplifier output, U phase
CH48	CON26-6	Inverter base amplifier output, V phase
CH49	CON24- 10	Inverter base amplifier output, W phase
CH50	CON22-2	Inverter base amplifier output, \bar{U} phase
CH51	CON22-2	Inverter base amplifier output, \bar{V} phase
CH52	CON22-2	Inverter base amplifier output, \bar{W} phase
CH53	CON23-2	Converter base amplifier output, R phase
CH54	CON23-6	Converter base amplifier output, S phase
CH55	CON23- 10	Converter base amplifier output, T phase
CH56	CON22-5	Converter base amplifier output, \bar{R} phase

Terminal No.	Common	Description
CH57	CON22-5	Converter base amplifier output, \bar{S} phase
CH58	CON22-5	Converter base amplifier output, \bar{T} phase

4.2 Card SF-OR

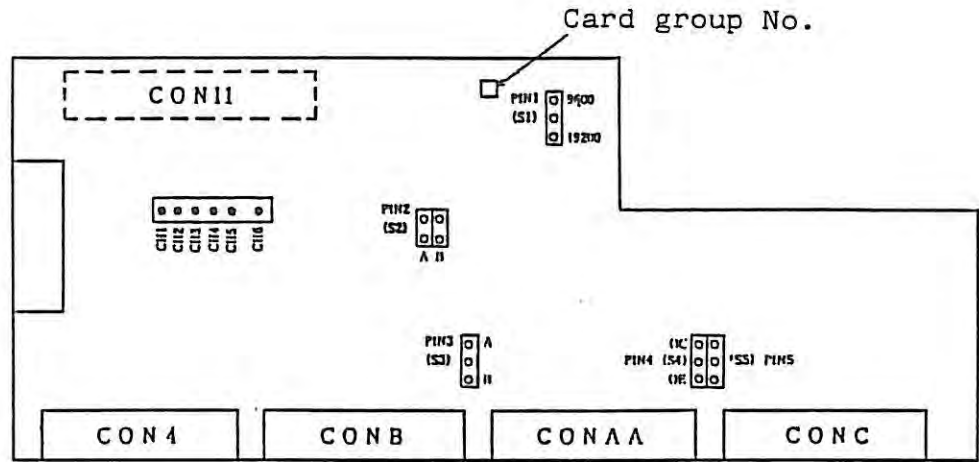

Note: Name of pin may differ depending on card group No. (G51, G52).











G51	(S1)	(S2)	(S3)	(S4)	(S5)
	↓	↓	↓	↓	↓
After G51	PIN1	PIN2	PIN3	PIN4	PIN5

Led 4 7
#9

Led #2

F12-SF-J

(1) Jumper pin list

Pin No.	Name	Setting	Description
PIN (S1)	Baudrate selection	 9600 19200	CON60 serial interface baudrate is set to 9600.
		 9600 19200	CON60 serial interface baudrate is set to 19200.
PIN2 (S2)		 A B	(Currently not used)
		 A B	(Currently not used)
PIN3 (S3)	Oriented spindle stop encoder power supply	 A B	Power supply of NC is not available.
		 A B	Power supply of NC is available.
PIN4 (S4)	Oriented spindle stop position com- mand inter- face selec- tion	 OE	Synchro drive (open collector)
		 OE	Source drive (open emitter)
PIN5 (S5)	Oriented spindle stop position com- mand inter- face common output selec- tion	 OE	CONC-14 is used for DGA.
		 OE	CONC-14 is used for 24V.

(2) Check terminal list

Terminal No.	Common	Description
CH1	DGA	Position feedback, A phase
CH2	DGA	Position feedback, B phase
CH3	DGA	Position feedback, Z phase
CH4	AGA	Magnesensor output
CH5	DGA	Magnesensor, linear zone output
CH6		Digital signal, common (DGA)

Note: Common "AG" should be take from CH9 of card SF-CA.

4.3 Card SF-TL

(1) Parts arrangement, card G51 group

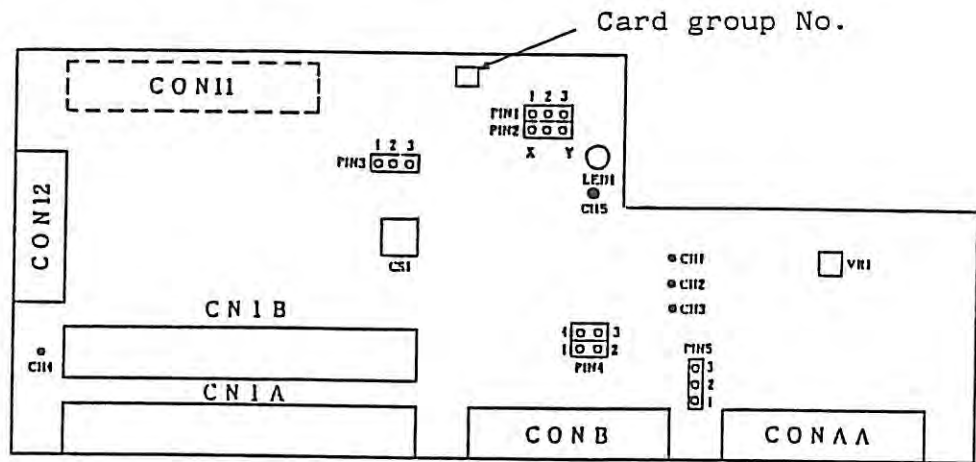

(2) Parts arrangement, card G52 group

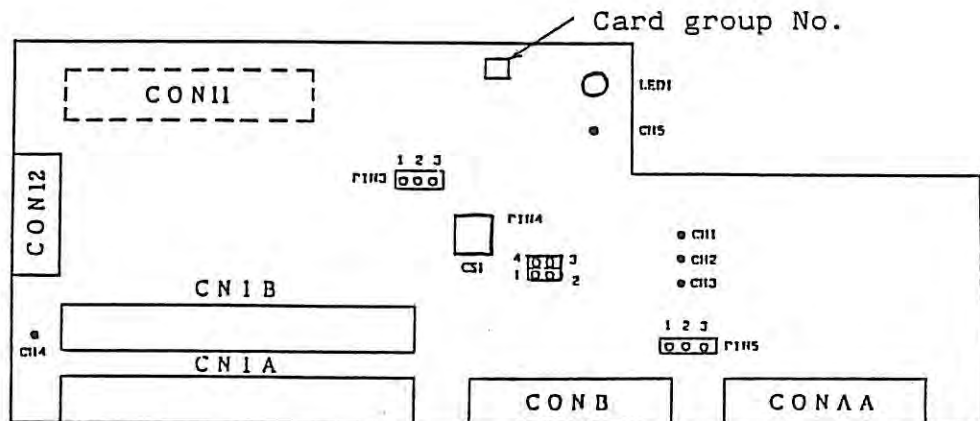

(3) Switch list

Name	Description
CS1	Rotary switch for axis No. setting. Usually, it is set to "6". When C-axis control is used, C axis No. is set.

(4) Jumper pin list

Pin No.	Name	Setting	Description
PIN1 PIN2 (Not provided for card group No. 52)	CONAA output selection		Encoder feedback signal from CONB is output.
			Feedback signal from motor detector (CON2) is output to CONAA. For Z phase, linear zone of magnet-sensor is output.
			Feedback signal from motor detector (CON2) is output to CONAA.
PIN3	Baudrate selection		CON12 serial interface baudrate is set to 19200.
			CON12 serial interface baudrate is set to 9600.
PIN4	Test pin		Usual, "1" is connected to "2". When "1-2" is opened and "3-4" is closed, emergency stop signal coming through bus-link cable is ignored.
PIN5	Oriented spindle stop encoder power supply		Power supply of NC is not available.
			Power supply of NC is available.

(5) LED list

LED No.	Description
LED1	Encoder open circuit detection This LED lights when magnesensor is used (it does not detect open circuit of magnesensor).

(6) Potentiometer list

VR No.	Description
VR1	Magnesensor sensitivity is adjusted.

Note: VR1 is not used in cards after card group No. G52.

(7) Check terminal list

Terminal No.	Common	Description
CH1	DGA	Position feedback, A phase
CH2	DGA	Position feedback, B phase
CH3	DGA	Position feedback, Z phase
CH4	AGA	Magnesensor output (MS signal)
CH5	DGA	Linear zone output (LS signal)

*Common DGA and AGA should be taken from card SF-CA.

4.4 Card SF-PW

This card provides all DC power supplies necessary for FR-SF.

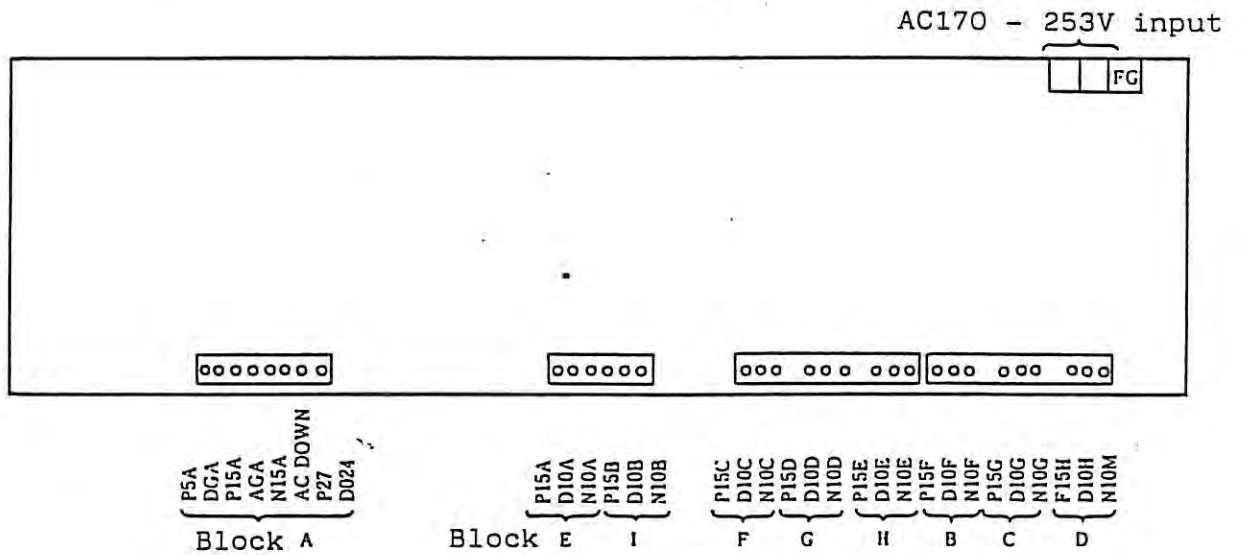

- Notes: 1. All blocks other than block A are not insulated from the main circuit.
2. "0" line of block A is connected internally.

Block	Name	Common		DC output voltage	
A	P 5 A	D G A	Common	+ 5 V	± 3 %
	P 2 4 A	D 0 2 4		+ 2 4 V	± 1 0 %
	P 1 8 A	A G A		+ 1 8 V	± 1 0 %
	N 1 8 A			- 1 8 V	± 1 0 %
B	P 1 5	D 1 0 F	+ 1 5 V	± 1 0 %	
	N 1 0		- 1 0 V	± 1 0 %	
C	P 1 5	D 1 0 G	+ 1 5 V	± 1 0 %	
	N 1 0		- 1 0 V	± 1 0 %	
D	P 1 5	D 1 0 H	+ 1 5 V	± 1 0 %	
	N 1 0		- 1 0 V	± 1 0 %	
E	P 1 5	D 1 0 A	+ 1 5 V	± 1 0 %	
	N 1 0		- 1 0 V	± 1 0 %	
F	P 1 5	D 1 0 C	+ 1 5 V	± 1 0 %	
	N 1 0		- 1 0 V	± 1 0 %	
G	P 1 5	D 1 0 D	+ 1 5 V	± 1 0 %	
	N 1 0		- 1 0 V	± 1 0 %	
H	P 1 5	D 1 0 E	+ 1 5 V	± 1 0 %	
	N 1 0		- 1 0 V	± 1 0 %	
I	P 1 5	D 1 0 B	+ 1 5 V	± 1 0 %	
	N 1 0		- 1 0 V	± 1 0 %	
J	ACDOWN signal				

§5. ADDITION AND REPLACEMENT OF COMPONENT

Before a component is added or replaced, be sure to turn off the main power supply.

5.1 Addition of option card (SF-OR, SF-DA, SF-TL)

When an option card is added to a controller having no option card, follow the procedure and caution described below.

Procedure:

- (1) Remove the front panel of controller (4 panel mounting screws should be removed).
- (2) Place the option card on the card SF-CA, where space is provided for installation of option card, and secure the option card with five mounting screws.
- (3) Perform the required settings
(Refer to page for card setting, and to page for parameter setting.)

Due care should be taken if parameter(s) must be set. Option card is shipped with the standard settings. Upon reception of option card, check it against the specification for setting.

- (4) When setting is changed, the setting table in the order sheets attached to the controller should be revised in accordance to the change.
- (5) Install the controller front panel.
- (6) Affix the "option card nameplate" attached to the option card to the controller front panel, as shown below.

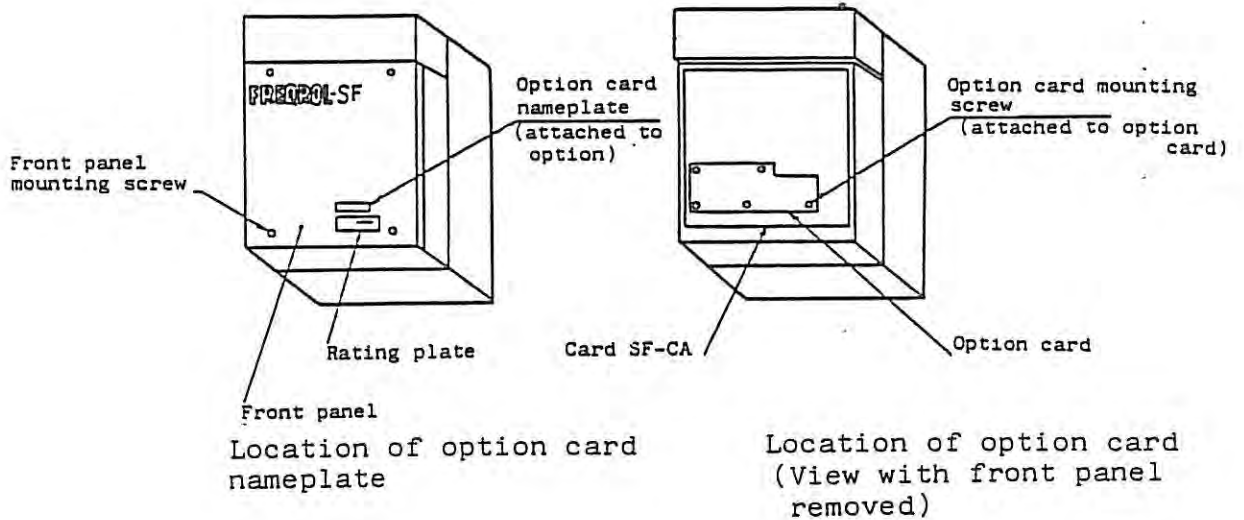

5.2 Replacement of card

For replacement of card, the controller front panel should be removed (remove 4 mounting screws).

(1) Card SF-CA

To replace card SF-CA, remove 2 card mounting screws and disengage 6 card locks.

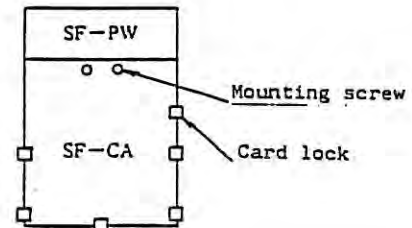

CAUTION:

Before replacement, check ROM No., switch settings and jumper pin settings.

When it is desirable to use the previous parameter settings, remove the parameter ROM (E² ROM) from the old card and load it to the new card.

Check engagement of the connector with the SF-PW (connector pins of SF-PW should protrude about 1 - 2mm).

Adjustment:

- (a) CH40 - CH9 (AG) (U-phase inverter current) VR2
- CH41 - CH9 (AG) (V-phase inverter current) VR3

Zero adjustments should be accomplished on VR2 and VR3.

550 WOOD

SFCA

2F

C1

(b) Set SW5-4 to "ON" and perform full-scale adjustments for the following meters:

Speed meter VR4

Load meter VR5

(After adjustment, set SW5-4 to "OFF" position.)

(2) Cards SF-OR, SF-DA and SF-TL

To replace, remove 5 mounting screws.

CAUTION:

Before replacement, check switch settings and jumper pin settings.

(3) Card SF-PW

To replace, remove card SF-CA, lead terminal screws (3 screws) of card SF-PW, and 4 SF-PW card mounting screws.

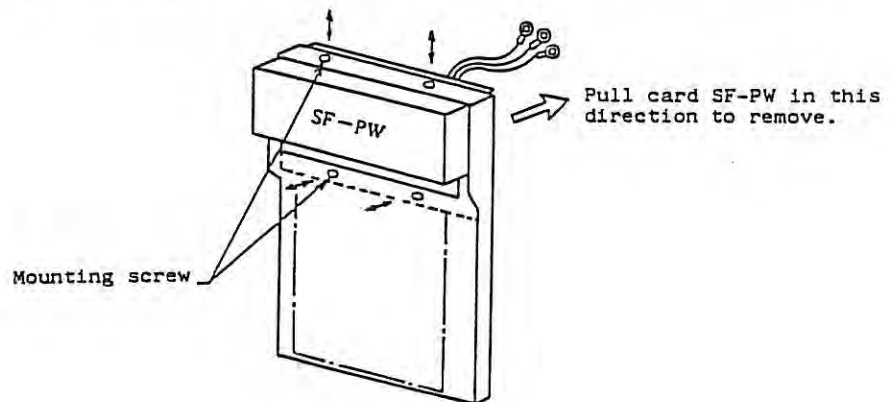

CAUTION:

Each lead of card SF-PW should be identified.

One of white or red leads RO terminal

One of white or red leads SO terminal

Green lead E terminal

5.3 Replacement of ROM

ROMs should be handled in pair; ROM1 (2F) and ROM2 (4F).

Procedure:

(1) Remove the controller front panel (remove 4 panel mount-

ing screws).

(2) Remove the ROMs.

To remove the ROMs, be sure to use a ROM remover and carefully disengage each ROM from socket. Use care not to bend ROM pins.

(3) Load new ROMs.

To load, identify each ROM (see ROM No.) and check orientation.

After it is loaded, visually check for condition.

Example of ROM loading failure

① Example of loading failure

ROM tilts and its pins are not put into the socket securely.

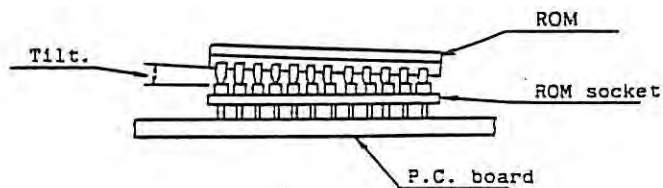

② Example of loading failure

ROM pin(s) is not put into the socket.

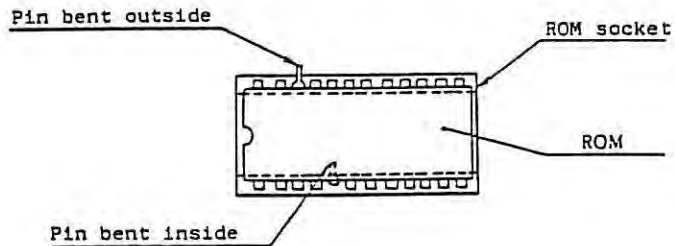

(4) After the replacement of ROMs, the corresponding description in the "order sheets" attached to the controller should be changed accordingly.

5.4 Replacement of diode module and transistor module

(1) Removal of defective module

Disconnect the wires from the module to be replaced and separate the module from the heatsink to remove the module. When transistor module is removed, note that the base terminal "B" and emitter terminal "E" are of plug-in type.

(2) Greasing

Apply uniform film of silicone grease to the back surface of the new module before loading.

(3) Installation

Connect the wires to the new module with the specified torque.

For transistor module, protect the base terminal and emitter terminal with silicone tubes, as they were.

CAUTION

Since the diodes and transistors are of special specification, use the specified one for replacement.

When your hand may directly touch base terminal "B" or terminal "E" of transistor module, use a grounding means to prevent damage to the transistor module, due to static charge.

	Model	Screw size	Max. clamping torque (kg-cm)	Recommended clamping torque (kg-cm)
Diode	PT768	M5×0.8	20	17±2
	PD608			
	PD1008			
Transistor	UM75CDY-10	M5×0.8	20	17±2
	UM100CDY-10			
	UM150CDY-10			

Table 5.1 Clamping torque table

5.5 Disassembly and assembly of SJ type AC spindle motor

1 Cables and P.C. board

(1) Remove the cover of terminal box located on the fan case.

(2) Disconnect the cables coming from the electric enclosure.

a) 3 motor main leads (U,V and W).

b) 2 cooling fan leads (BU and BV).

c) 2 thermal protector leads (OHS1 and OHS2).

d) Cable connected to the external connector of P.C. board.

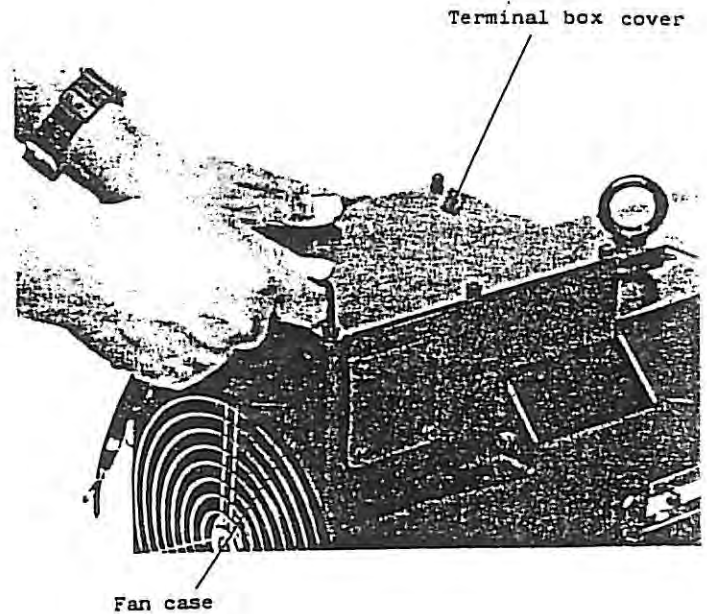

(3) Remove the external connector from the connector bracket.

Disengage the internal connector.

(4) Remove the P.C. board mounting pan head screws to remove the P.C. board.

(5) To assemble, perform the reverse steps.

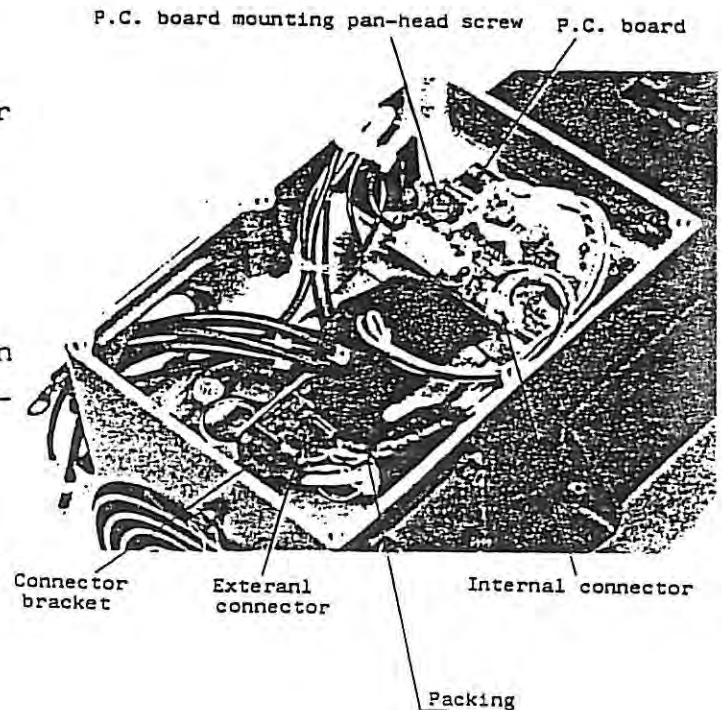

2 Cooling fan

For models smaller than 132Fr

- (1) Remove the hexagon socket head bolts used to secure the finger guard.

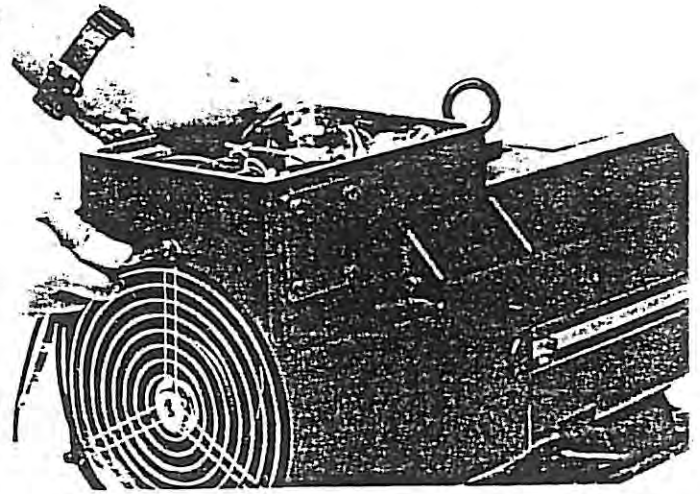

- (2) Remove the pan-head screws at the center of the cooling fan to remove the fan.

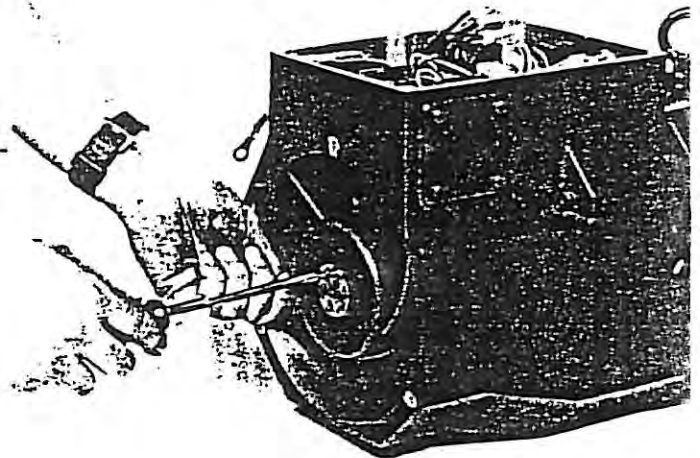

- (3) Cut the four fan leads.

Remove the pan head screws and draw out the fan motor from the fan case.

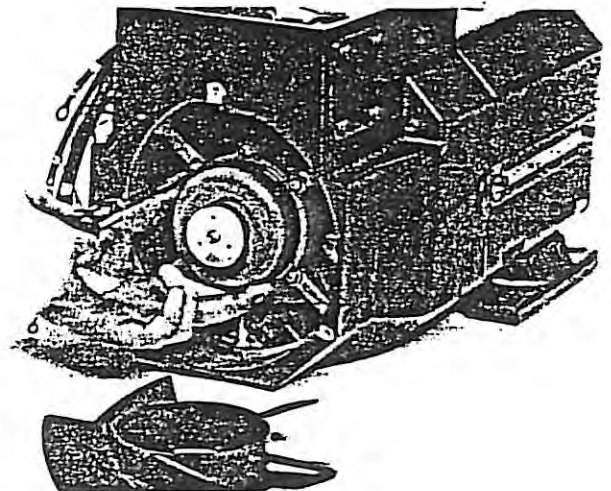

- (4) To assemble, perform the reverse steps ((3)→(1)).

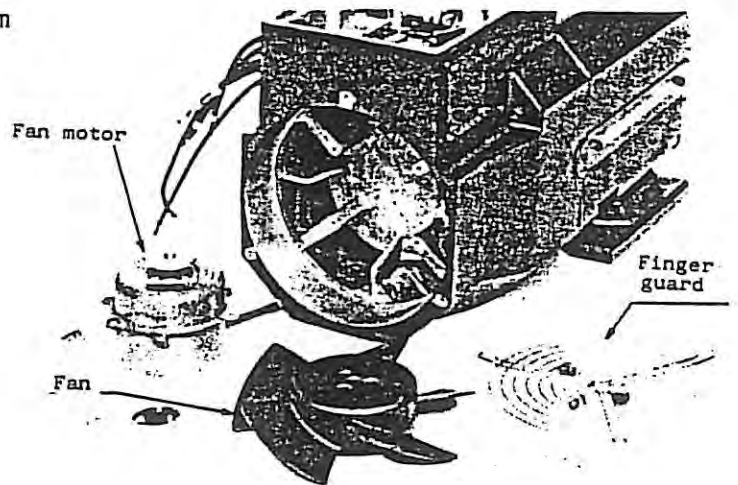

For models larger than frame No. 160

- (1) Remove 3 fan case mounting hexagon socket head screws. Pull back the fan case to remove the fan case together with fan.

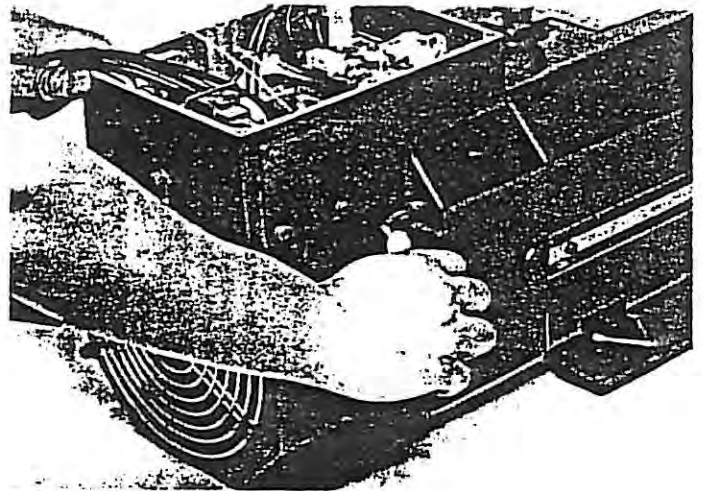

- (2) Remove the hexagon socket head bolts used to install the finger guard.

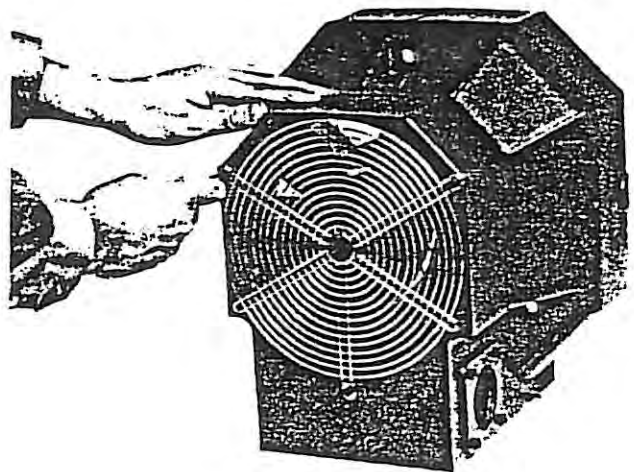

- (3) Cut the three leads of cooling fan. Remove the pan head screws used to install the cooling fan and draw out the fan from the fan case.

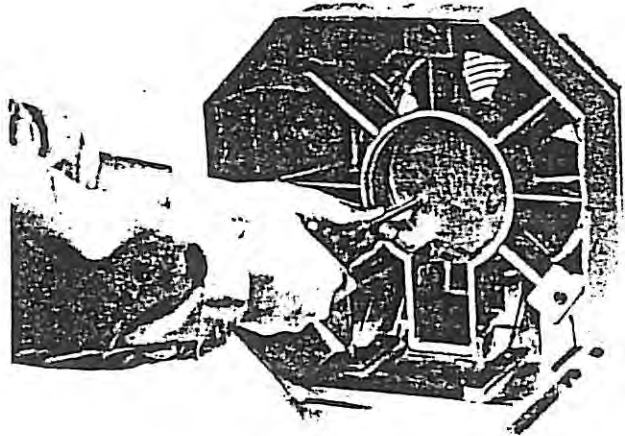

- (4) To assemble again, perform the reverse steps ((3) → (1)).

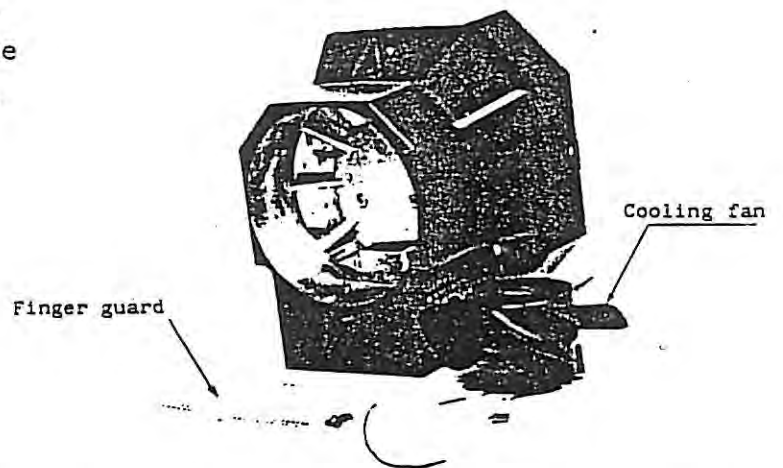

3 Sensor and sensor gear

- (1) Disengage the sensor connector (internal) from the P.C. board in the terminal box.
- (2) Remove the three fan mounting hexagon socket head screws. Pull back the fan case to remove the fan case together with fan.

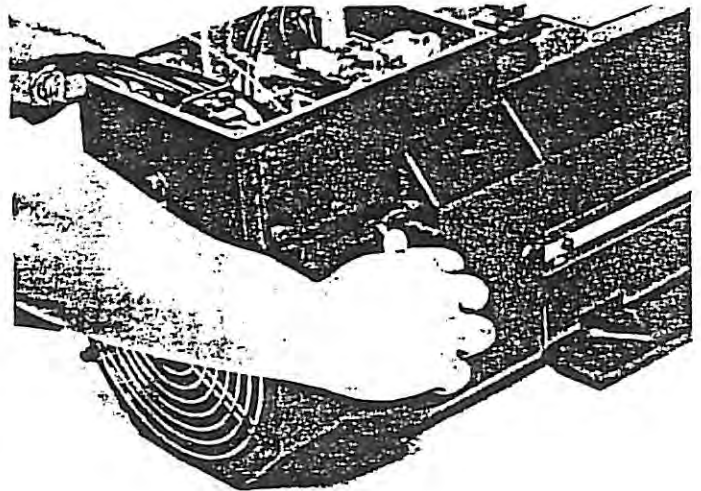

(3) Remove the two pan head screws used to install the sensor bracket to remove the sensor bracket together with sensor (take care to prevent hitting of the sensor against the sensor gear).

(4) To adjust sensor position, loosen the sensor mounting screw with the sensor bracket held in position and insert a thickness gauge into the gap between the sensor and the sensor gear. Adjust the gap to 0.15 ± 0.01 .

After making sure that the sensor marking lines are aligned with each other, tighten the sensor mounting screw to secure the sensor in position.

(5) Apply lock paint to the sensor mounting screw and the sensor bracket mounting screws.

(6) When the sensor is put into the fan case, arrange the sensor leads properly to prevent sensor lead from being wedged.

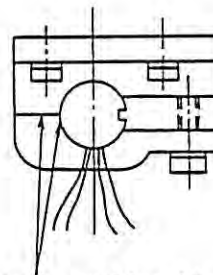
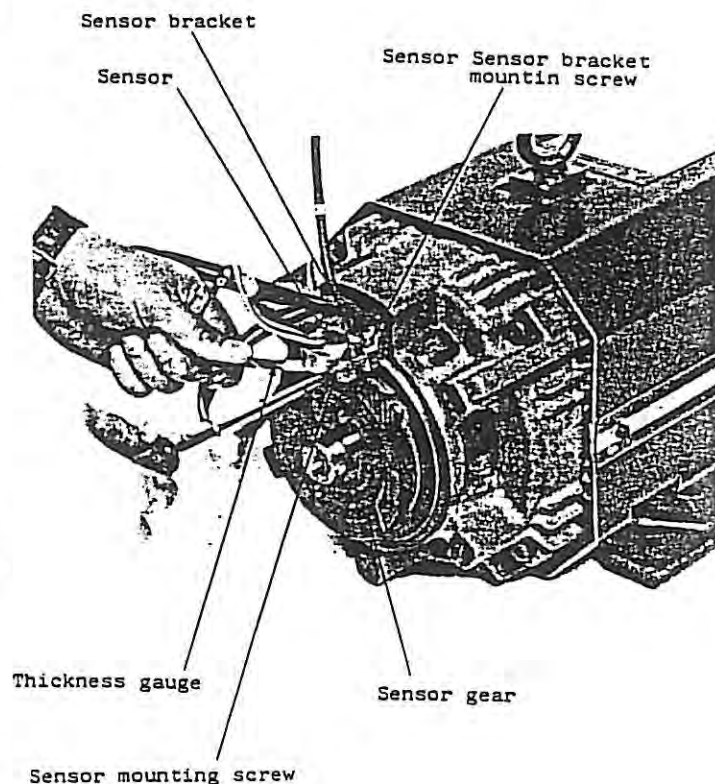

Align the marking lines with each other.

- (7) To remove the sensor gear, screw eye bolts (M8) into the tapped holes and apply a tool shown to the right to the bolts.

After the removal of the sensor gear, remove the two eye bolts.

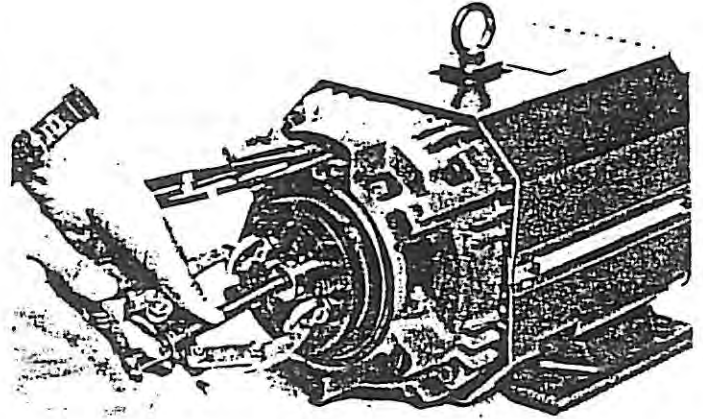

- (8) To install the sensor gear again, it must be shrinkage-fit at temperature within 100°C - 150°C.

Note that excessively high temperature may cause distortion to the gear.

4 Bearings

- (1) Remove the shaft case cover mounting screws and the bracket mounting hexagon socket head bolts and remove the bracket on the counter-load side.

- (2) When the bracket on the counter-load side is installed again, apply sealing compound to the fitting surface.

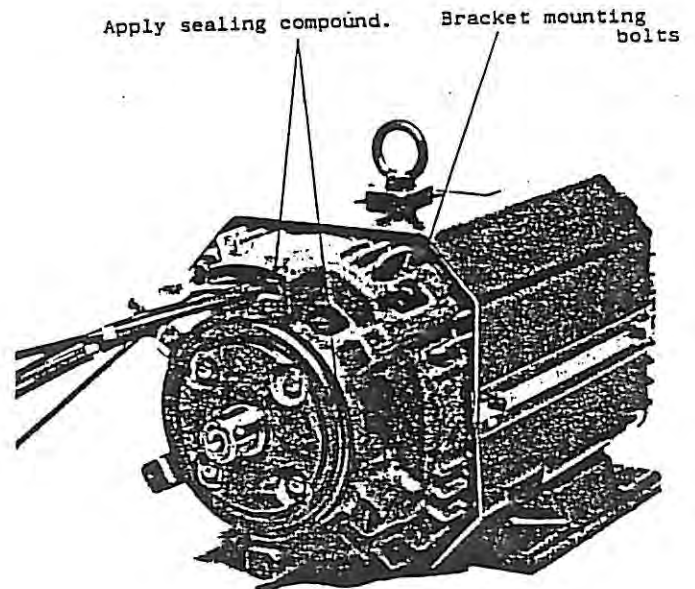

Shaft case cover mounting screw

- (3) To remove the bearing on the counter-load side, remove the shaft stop ring and apply a bearing remover. The bearing can be removed together with the shaft case cover.

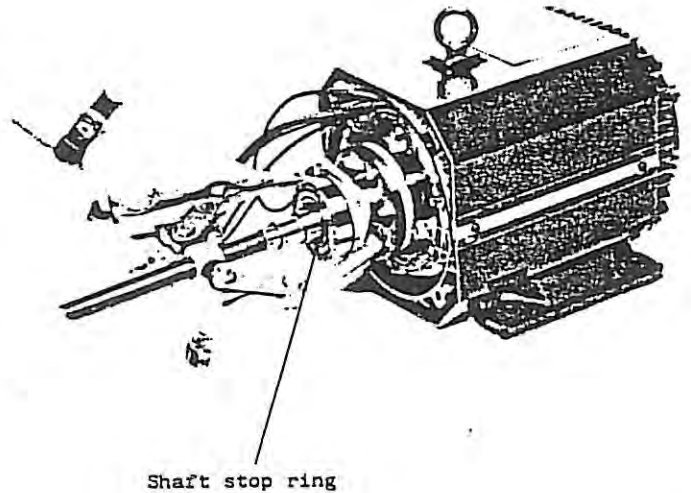

- (4) To remove the bearing on the load side, apply a bearing remover to the inner ring of bearing and turn the handle of bearing remover.

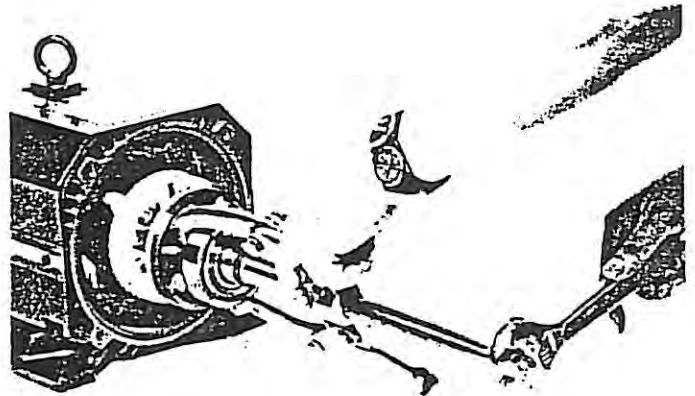

- (5) To install bearing to shaft, all fitting surfaces should be thoroughly cleaned and smoothed.

- (6) Apply grease to bearing bore surface and shaft. Put a pipe on the bearing inner ring and carefully depress the bearing by a press machine. Press machine is used to install

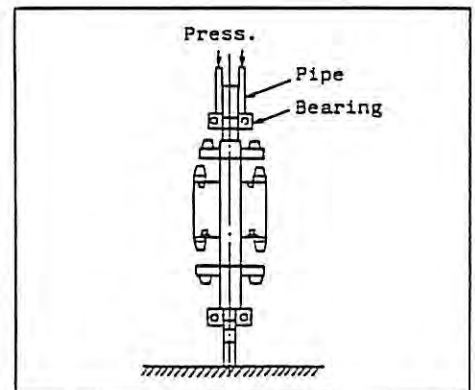

- (7) If press machine is not available, lightly hammer the pipe to drive. Use care not to hammer the outer ring of bearing.

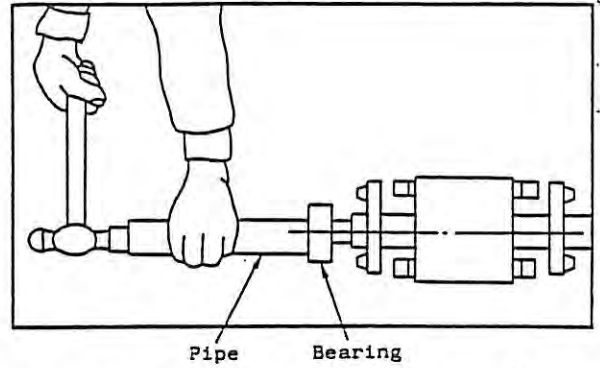

Hammer is used to install.

§6. INSTALLATION OF ORIENTED SPINDLE STOP POSITION DETECTOR

6.1 Magnesensor 1-point oriented spindle stop

6.1.1 Magnet and sensor

The sensor generates two types of voltage signal as shown in Fig. 6.1.

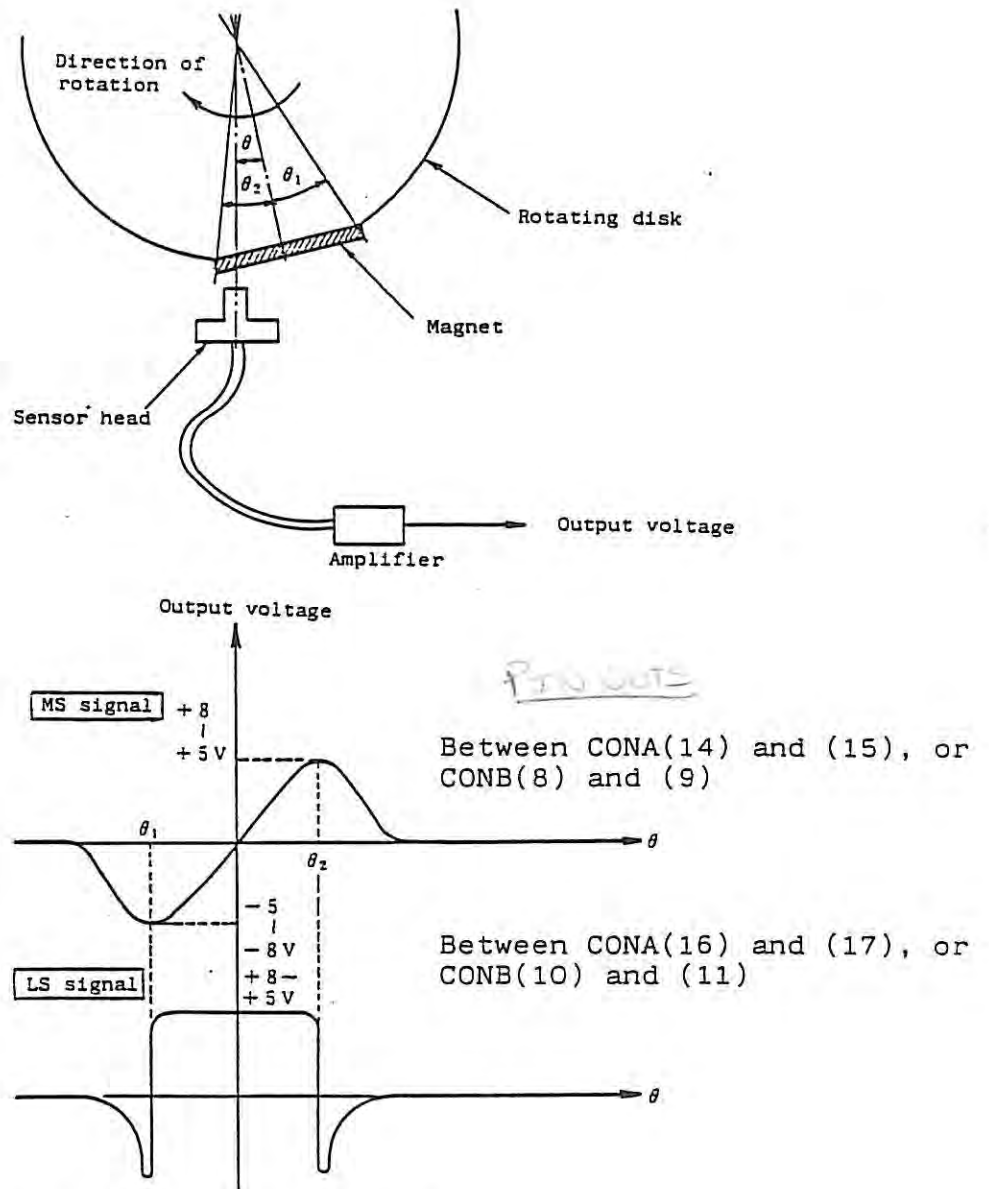

Fig. 6.1 Sensor signals

MS signal Signal voltage is zero volt when the center of magnet comes to the sensor head, and maximum at both the extremities of magnet.

Spindle is stopped with this signal at OV.

LS signal Signal voltage is constant within the zone (width) of magnet.

This signal is used to verify that spindle remains stopped within the zone of magnet.

6.1.2 Operation mode and motion pattern

(1) Operation mode

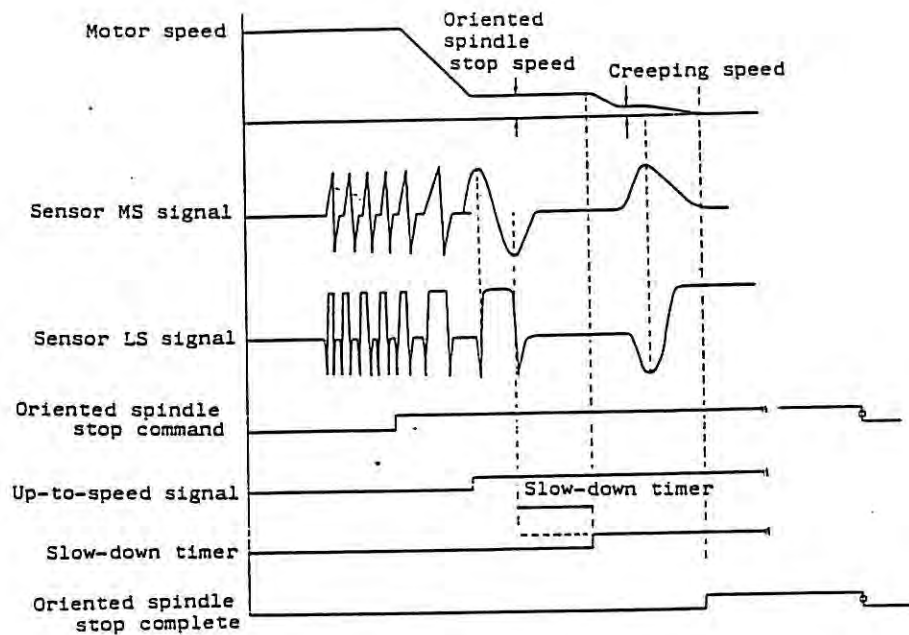

When direction of oriented spindle stop motion has been fixed (by parameter setting) and is inverse to the direction of normal spindle rotation (run), the motion pattern is as follows:

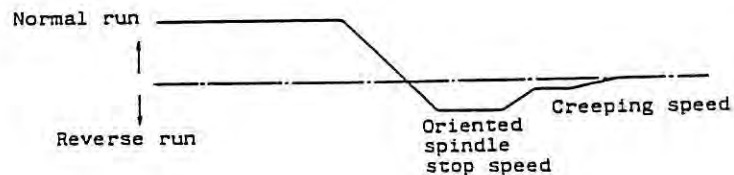

(2) Operation

- (a) When oriented spindle stop command signal turns on, motor speed changes to "oriented spindle stop speed".
- (b) When spindle speed reaches the oriented spindle stop speed, "up-to-speed" signal turns on.
- (c) When sensor "LS" signal falls to "L" after the up-to-speed signal turns on, the slow-down timer starts counting (software timer).
- (d) When the slow-down timer counts up, spindle speed changes from the oriented spindle stop speed to "creeping speed".
- (e) When sensor "LS" signal rises (H), control mode changes to positioning control mode.
- (f) The spindle stops when sensor "MS" signal turns on.
- (g) "Oriented spindle stop complete" signal turns on.

Direction of oriented spindle stop motion (set by parameter ORS2)

(1) PRE	Direction is same as that of previous rotation.
(2) NORMAL	Direction is same as that of normal spindle rotation.
(3) REVERSE	Direction is reverse to that of normal spindle rotation.

6.1.3 Types and outside dimensions of magnesensor

For oriented spindle stop, the following combinations of amplifier, sensor and magnet are available.

Type	Permissible speed (RPM)	Model	Combination		
			Amplifier	Sensor	Magnet
Standard	0~6000	MAGSENSOR BKO-C1810H01-3	H01	H02	H03
High-speed standard	0~12000	MAGSENSOR BKO-C1730H01.2.6	H01	H02	H06
High-speed miniature	0~12000	MAGSENSOR BKO-C1730H01.2.9	H01	H02	H09
High-speed ring	0~25000	MAGSENSOR BKO-C1730H01.2.11	H01	H02	H11
High-speed ring	0~30000	MAGSENSOR BKO-C1730H01.2.12	H01	H02	H12
High-speed ring	0~30000	MAGSENSOR BKO-C1730H01.2.13	H01	H02	H13
High-speed ring	0~30000	MAGSENSOR BKO-C1730H01.2.14	H01	H02	H14

Note: Combination of amplifier, sensor and magnet is possible within the same model group (C1810 or C1730).

Outside dimensions:

● Amplifier HO1

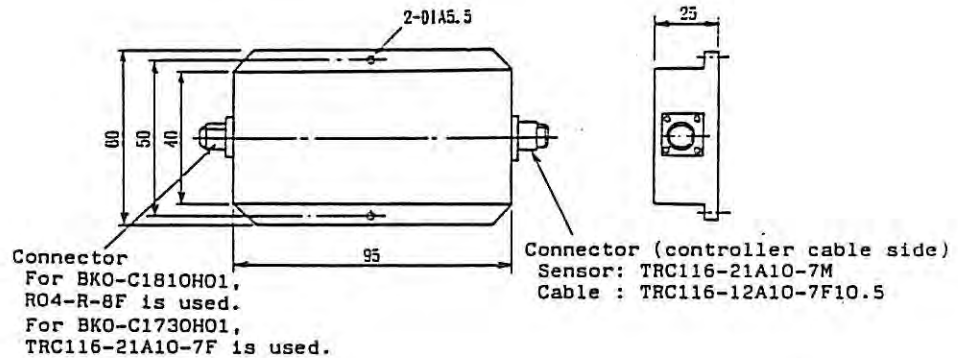

● Sensor HO2

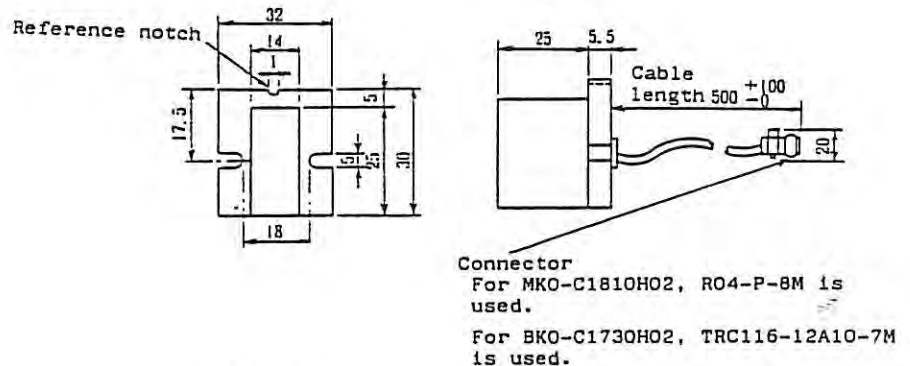

● Magnet

Part No.	Permissible speed (RPM)	Outside view																																																																						
H 0 3	0~6000	<p>Reference hole</p> <p>Weight: 40±1.5g</p> <p>Mounting screw: M4 screw</p>																																																																						
H 0 6	0~12000																																																																							
H 0 9	0~12000	<p>WEIGHT 14.8±0.7g</p> <p>Mounting screw: M4 screw</p>																																																																						
H 1 1	0~25000	<p>Case</p> <p>Cover</p> <p>RINGFEDER 1F33005 J×K</p> <p>4-F screw</p> <p>Stainless SUS-303</p> <p>Stop position scale</p> <p>Reference notch</p> <p>Gap L±0.1</p> <p>SENSOR</p> <p>2-φG±0.15φ On circumference</p> <p>※ Polarity (N,S) is indicated on the side wall of case. Sensor head should be installed so that the reference notch of sensor head comes on the case side.</p>																																																																						
H 1 2	0~25000																																																																							
H 1 3	0~30000	<p>Magnet Unit: mm</p> <table border="1"> <thead> <tr> <th rowspan="2">TYPE</th> <th colspan="10">Dimensions</th> <th rowspan="2">Weight (g)</th> </tr> <tr> <th>A</th> <th>B</th> <th>C</th> <th>D</th> <th>E</th> <th>F</th> <th>G</th> <th>H</th> <th>J×X</th> <th>L</th> </tr> </thead> <tbody> <tr> <td>BND-C1730H11</td> <td>105</td> <td>70I7+0.030 -0</td> <td>90</td> <td>28</td> <td>19</td> <td>18×1.0</td> <td>5</td> <td>90</td> <td>70×79</td> <td>1</td> <td>1021±1</td> </tr> <tr> <td>" H12</td> <td>94</td> <td>60I7+0.030 -0</td> <td>79</td> <td>25</td> <td>17</td> <td>15×0.8</td> <td>5</td> <td>79</td> <td>60×68</td> <td>1</td> <td>761±1</td> </tr> <tr> <td>" H13</td> <td>78</td> <td>50I7+0.025 -0</td> <td>66</td> <td>23</td> <td>15</td> <td>15×0.8</td> <td>5</td> <td>66</td> <td>50×57</td> <td>1</td> <td>478±1</td> </tr> <tr> <td>" H14</td> <td>70</td> <td>40I7+0.025 -0</td> <td>54</td> <td>20</td> <td>13</td> <td>11×0.7</td> <td>5</td> <td>54</td> <td>40×45</td> <td>1</td> <td>322±1</td> </tr> </tbody> </table>	TYPE	Dimensions										Weight (g)	A	B	C	D	E	F	G	H	J×X	L	BND-C1730H11	105	70I7+0.030 -0	90	28	19	18×1.0	5	90	70×79	1	1021±1	" H12	94	60I7+0.030 -0	79	25	17	15×0.8	5	79	60×68	1	761±1	" H13	78	50I7+0.025 -0	66	23	15	15×0.8	5	66	50×57	1	478±1	" H14	70	40I7+0.025 -0	54	20	13	11×0.7	5	54	40×45	1	322±1
TYPE	Dimensions										Weight (g)																																																													
	A	B	C	D	E	F	G	H	J×X	L																																																														
BND-C1730H11	105	70I7+0.030 -0	90	28	19	18×1.0	5	90	70×79	1	1021±1																																																													
" H12	94	60I7+0.030 -0	79	25	17	15×0.8	5	79	60×68	1	761±1																																																													
" H13	78	50I7+0.025 -0	66	23	15	15×0.8	5	66	50×57	1	478±1																																																													
" H14	70	40I7+0.025 -0	54	20	13	11×0.7	5	54	40×45	1	322±1																																																													
H 1 4	0~30000	<p>G hole</p> <p>Reference notch</p> <p>Spindle</p> <p>Case</p> <p>Cover</p> <p>clamping screw</p> <p>h6</p> <p>Installation of magnet</p> <p>Caution on installation of H11 - H14</p> <ol style="list-style-type: none"> 1. Tolerance to shaft dimension should be "h6". 2. 2-φG holes can be used for positioning of spindle and magnet. 3. Magnet shall be installed as shown to the left. 4. Misalignment between sensor head and magnet center line shall be within ±2mm. 5. Reference notch of sensor head shall come on the case side. 																																																																						

6.1.4 Orientation of magnet and sensor head

The magnet and sensor head should be installed in the specified orientation.

Standard type High-speed standard type The center reference hole of magnet and the reference notch of sensor head should come on the same side. Refer to **CASE 1**, **CASE 2**, **CASE 3** and **UNACCEPTABLE EXAMPLE 1**.

High-speed miniature type The reference notch of sensor head should be located in reference with polarity (N, S) of magnet. Refer to **CASE 4**, **CASE 5** and **UNACCEPTABLE EXAMPLE 2**.

High-speed ring type The reference notch of sensor head should be located in reference with polarity (N, S) of magnet. Refer to **CASE 6**, **CASE 7** and **UNACCEPTABLE EXAMPLE 3**.

CASE 1 Magnet is installed on the circumferential surface of rotating disk. The center reference hole of magnet and the reference notch of sensor head should come on the counter-load side, as shown in Fig. 6.3.

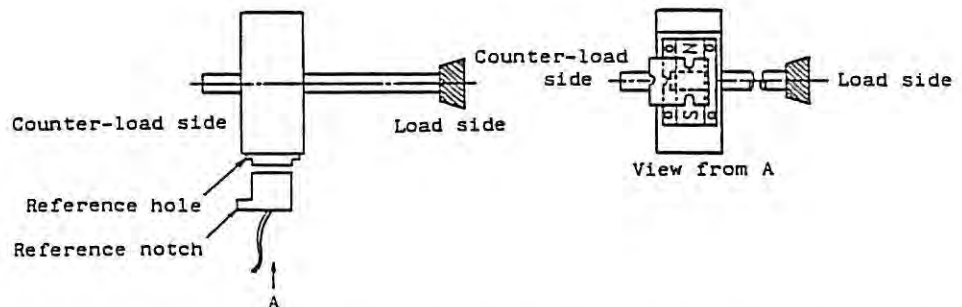

Magnet is installed on circumferential surface of rotating disk.

CASE 2 Magnet is installed on the front or back flat surface of rotating disk.

(1) When the magnet is installed on the counter-load side of spindle, the reference hole of magnet and reference notch of sensor head should face inward, as shown in Fig. 6.4.

(2) When the magnet is installed on the load side of spindle, the reference hole of magnet and reference notch of sensor head should face outward, as shown in Fig. 6.5.

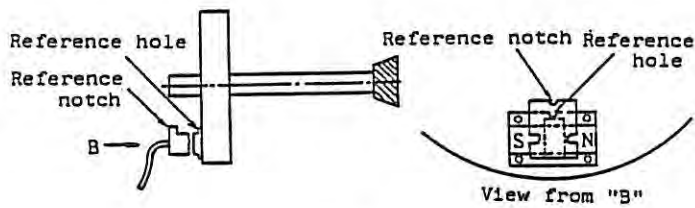

Magnet is installed on the counter-load side.

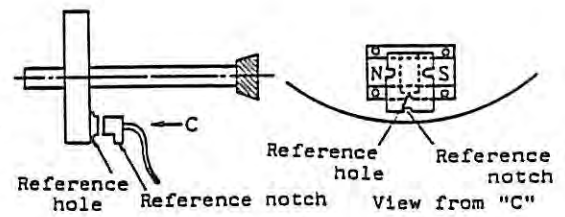

Magnet is installed on the load side.

CASE 3 In **CASE 1**, the magnet and sensor head can be located, as shown below, so far as the magnet is aligned with the sensor head correctly.

When the magnet and sensor head are installed, as shown below, however, bit for parameter (orientation of oriented spindle stop detector) must be changed correspondingly (parameter ORS2).

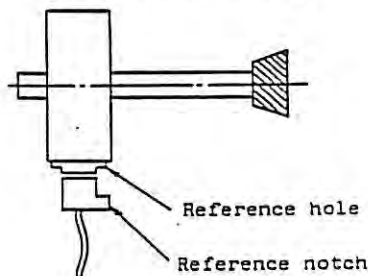

UNACCEPTABLE EXAMPLE 1

.... If the reference hole of magnet and the reference notch of sensor head are not on the same side, intense vibration occurs when the sensor head is at extremity of the magnet (oriented spindle stop is impossible).

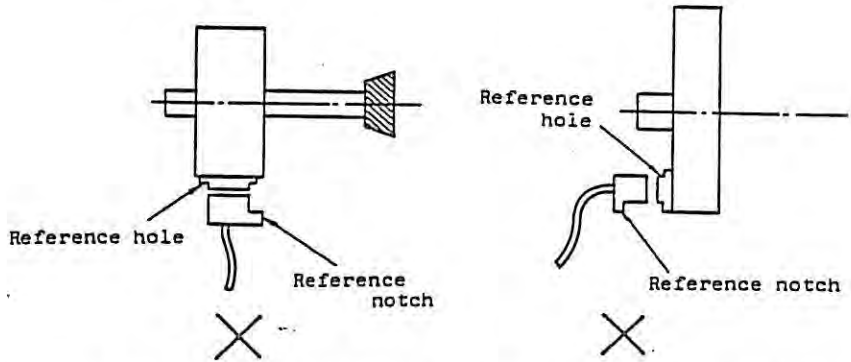

CASE 4

.... Magnet is installed on the circumferential surface of rotating disk.

The reference notch of sensor head should be on the counter-load side and the magnet should be installed in the polarity shown below.

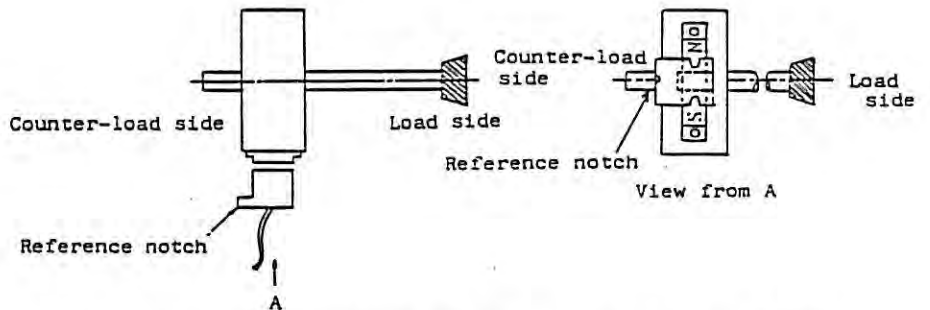

Magnet is installed on the circumferential surface of rotating disk.

CASE 5

.... So far as the relationship between location of the reference notch of sensor head and the polarity of the magnet is in accordance with **CASE 4**, the sensor head and the magnet can be installed as shown below.

(Bit for parameter (orientation of oriented spindle stop detector) must be changed cor-

respondingly parameter ORS2)

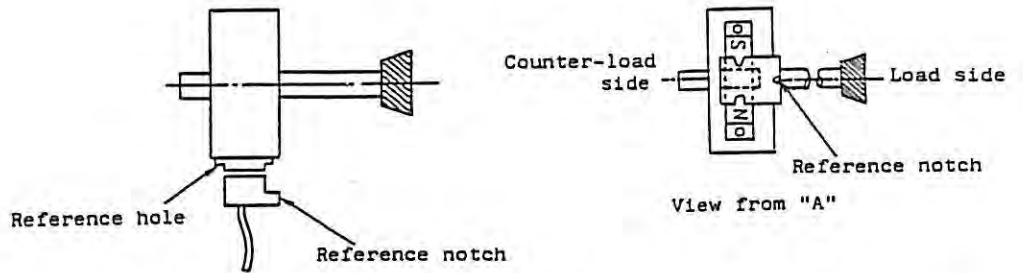

UNACCEPTABLE EXAMPLE 2

.... If the reference notch of sensor head is not located properly in reference to polarity of the magnet, intense vibration occurs when the sensor head is at extremity of the magnet, and oriented spindle stop is impossible.

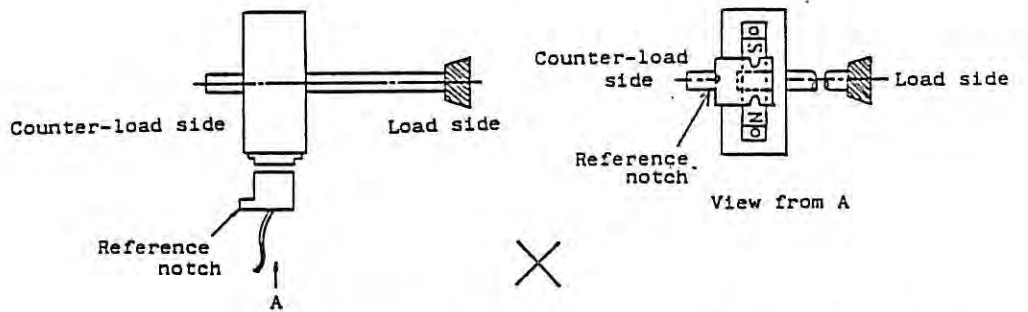

In this example, polarity (N, S) of magnet is inverse to that in **CASE 4**.

CASE 6

.... The reference notch of sensor head is on the counter-load side of spindle and the polarity of the magnet is as shown below.

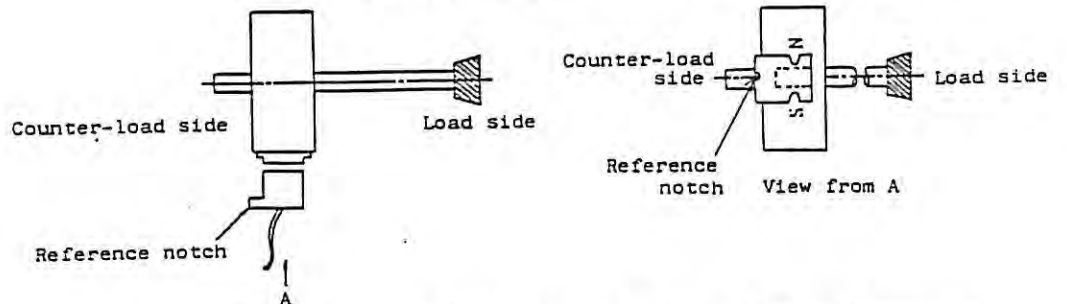

Magnet is installed on the circumferential surface of rotating disk.

CASE 7

.... So far as the relationship between location of reference notch of sensor head and the polarity of the magnet is in accordance with **CASE 4**, the sensor head and the magnet can be installed as shown below.

(Bit for parameter ORS2 (orientation of oriented spindle stop detector) must be changed correspondingly.)

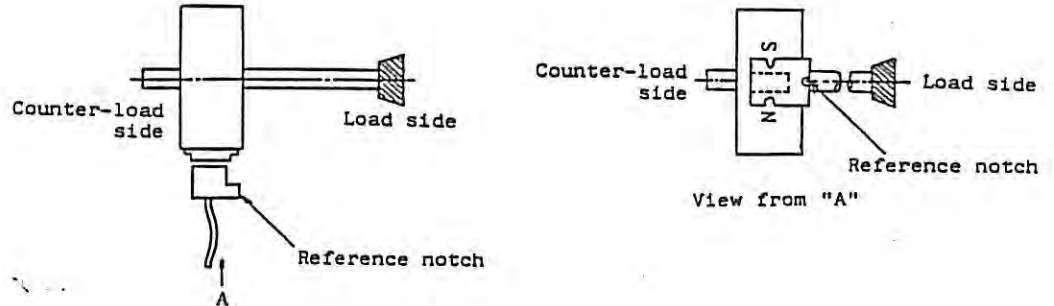

UNACCEPTABLE EXAMPLE 3

.... If the reference notch of sensor head sensor is not located properly in reference to polarity of the magnet, intense vibration occurs when the sensor head is at extremity of the magnet, and oriented spindle stop is impossible.

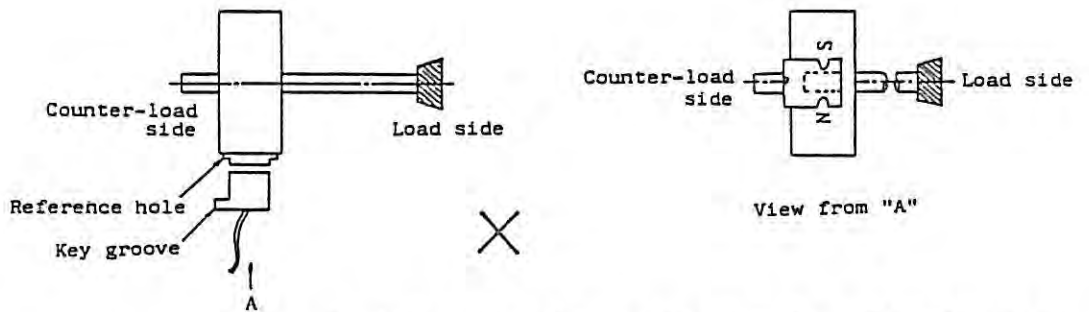

In this example, polarity (N, S) of magnet is inverse to that in **CASE 4**.

6.1.5 Caution on installation of magnet

When the magnet is installed to the spindle, pay attention to the following:

- (1) Do not locate an intense magnetic source near the magnet.

- (2) Carefully handle the magnet, avoiding mechanical shock to the magnet.
- (3) Secure the magnet to the spindle with appropriate screws.
For applicable screws, refer to the drawing showing the outside view of magnet.
- (4) After the magnet is installed, balance the entire spindle.
- (5) Align the center of the magnet (between N and S) with the center line of the rotating disk and make sure the orientation of the magnet and sensor head is as indication in CASE 1 - CASE 7.
- (6) Keep clean the magnet and its peripheral to be free from iron particles (iron particles may cause malfunction).
- (7) Apply lock paint, or other suitable means, to prevent mounting screw from becoming loose.
- (8) If the magnet is installed on a ground rotating disk, demagnetize the disk.
- (9) Diameter of rotating disk on which the magnet (other than ring type) is installed should be within the range from 80mm to 120mm.
When spindle speed is low, however, use a rotating disk of larger diameter.
- (10) If speed of the spindle exceeds 6,000rpm, use a high-speed type, high-speed miniature type or high-speed ring type magnet.

6.1.6 Caution on installation of sensor head

- (1) Install the sensor head in accordance with CASE 1 - CASE 7.
- (2) Align the center line of sensor head with the center

of magnet.

- (3) Gap between the magnet and the sensor head is listed in Table 1 - Table 3.

When a standard type magnet is installed in accordance with **CASE 1** or **CASE 3**, refer to Table 1.

When a high-speed standard magnet is installed in accordance with **CASE 1** or **CASE 3**, refer to Table 1.

When a standard magnet is installed in accordance with **CASE 2**, refer to Table 2.

When a high-speed standard magnet is installed in accordance with **CASE 2**, refer to Table 2.

When a high-speed miniature magnet is installed in accordance with **CASE 1** or **CASE 3**, refer to Table 3.

*When magnets are mass-produced, it is recommended to prepare jigs for production.

- (4) Connector for BKO-C1810 is oil-proof. Connector for BKO-C1730 is not oil-proof. It is recommended that the connector is located where is free from oil.
- (5) The cable between the amplifier and the controller should be laid down apart from high-voltage cables.
- (6) Check the connector wiring, securely engage the connector and tighten connector lock screws.

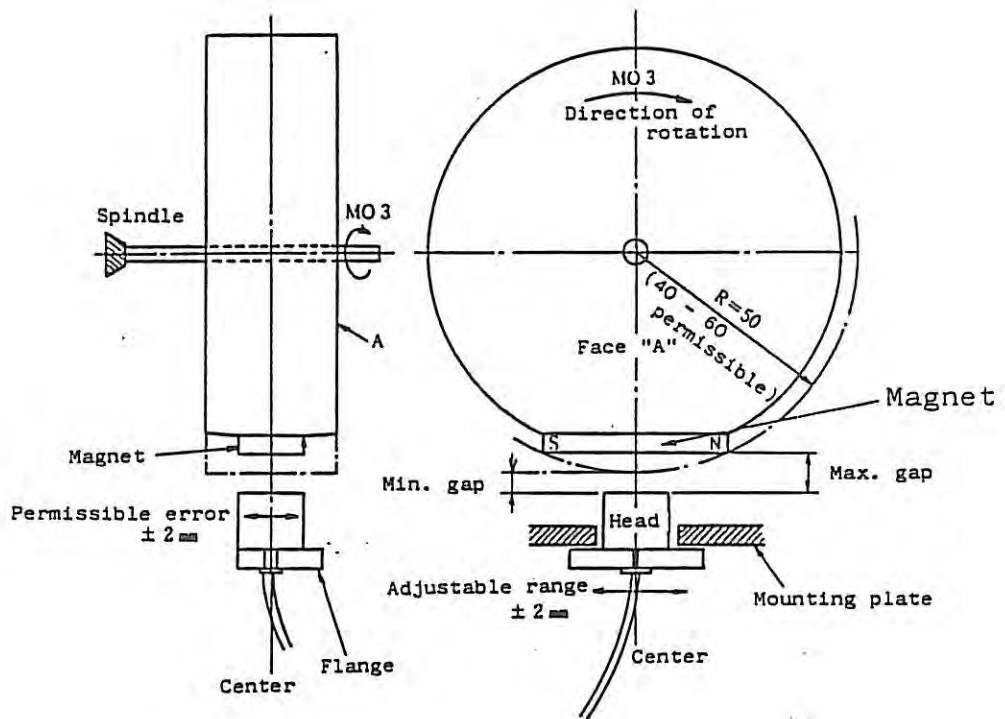

Table 1

Radius (R) mm	BKO-C1810H03		BKO-C1730H06	
	Max. gap mm	Min. gap mm	Max. gap mm	Min. gap mm
40	11.5±0.5	2.7±0.5	10±0.5	1.22±0.5
50	9.5±0.5	2.8±0.5	8±0.5	1.31±0.5
60	8.5±0.5	3.0±0.5	7±0.5	1.5±0.5
70	8.0±0.5	3.4±0.5	7±0.5	2.38±0.5

Table 2

Radius (R) mm	BKO-C1810H03	BKO-C1730H06
	gap mm	gap mm
40	6±0.5	5±0.5
50	∕	∕
60	∕	∕

Table 3

Radius (R) mm	BKO-C1730H09	
	Max. gap mm	Min. gap mm
40	6.25±0.5	3.3±0.5
50	6.0±0.5	3.7±0.5
60	5.75±0.5	3.85±0.5
70	5.5±0.5	3.87±0.5

6.2 Encoder type oriented spindle stop (4096 points)

6.2.1 Operation mode

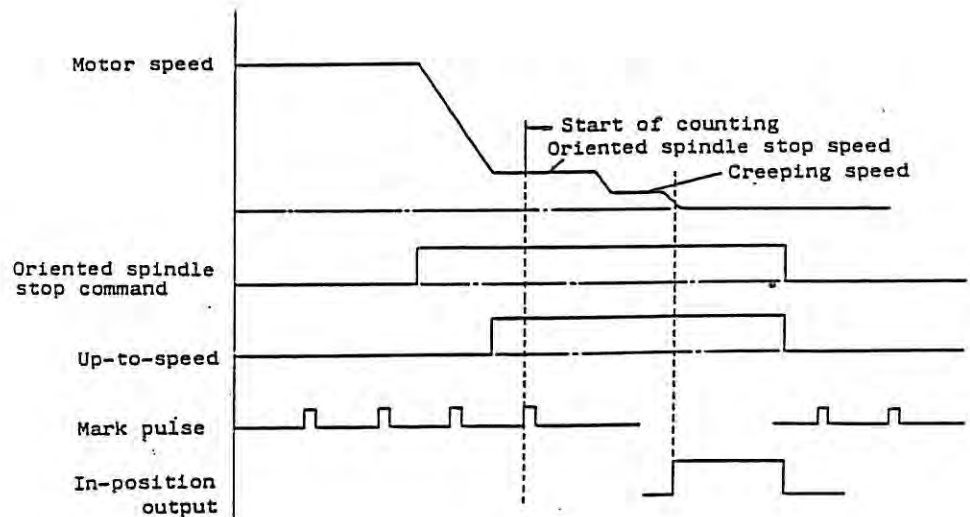

6.2.2 Operation

- (1) When oriented spindle stop command signal turns on, the spindle stop position specified by parameter PST is read and motor speed is changed to "oriented spindle stop speed".
- (2) When motor speed reaches the specified oriented spindle speed, "up-to-speed" signal turns on.
- (3) When a mark pulse is input after the up-to-speed signal turns on, the counter starts counting. The oriented spindle stop speed remains unchanged.
- (4) When the spindle reaches 146° - 225° from the specified stop position, spindle speed changes from the oriented spindle stop to "creeping speed".
- (5) When the spindle reaches 15° - 25° from the specified stop position, control mode changes to "positioning control loop". The spindle stops when it reaches the specified position.
- (6) "Oriented spindle stop complete" signal (contact ORA1 - ORA2 signal) is output when the spindle enters the zone

(stop position ± in-position range), specified by parameter ZRZ.

- (7) When the oriented spindle stop command is withdrawn, motor speed returns to the previous speed.
- (8) If oriented spindle stop command is given again during oriented spindle stop motion, the spindle orient-stops after one revolution of rotation.
The spindle, however, may rotate over one revolution, depending on settings of oriented stop position and position shift (parameter PST).
- (9) When "machine ready complete" signal (SET1, SET2) is turned off and then on while the spindle is in oriented stop condition, the spindle remains stopped.
- (10) Stop position (SF - OR when card DA is used)

Stop position can be specified by 12-bit signal (O1H - 12H). When all bits are off, the spindle stops at the basic stop position (0 deg.).

$$\text{Stop position} = \frac{360}{4096} [(H_{12}) \cdot 2^{11} + (H_{11}) \cdot 2^{10} + \dots + (H_1) \cdot 2^0]$$

Ex.: When only "H10" is on, the spindle stop position is,

$$\frac{360}{4096} \times 512 (2^9) = 45^\circ$$

The least setting increment is, $360^\circ / 4096 = 0.088^\circ$

Integer (1, 10,), if specified for stop position, causes error, due to fraction from multiplied least setting increment (0.088).

The relationship between orientation of installed encoder and stop position is as follows:

	Case 1	Case 2
Orientation of installation	<p>Encoder Motor Belt - View A</p>	<p>- View A</p>
Normal oriented spindle stop	<p>View from "A"</p> <p>Normal 0 Reverse</p> <p>400H (90°) 800H (180°) COOH (270°)</p>	<p>View from "A"</p> <p>Normal 0 Reverse</p> <p>COOH (270°) 800H (180°) 400H (90°)</p>

6.2.3 Composition

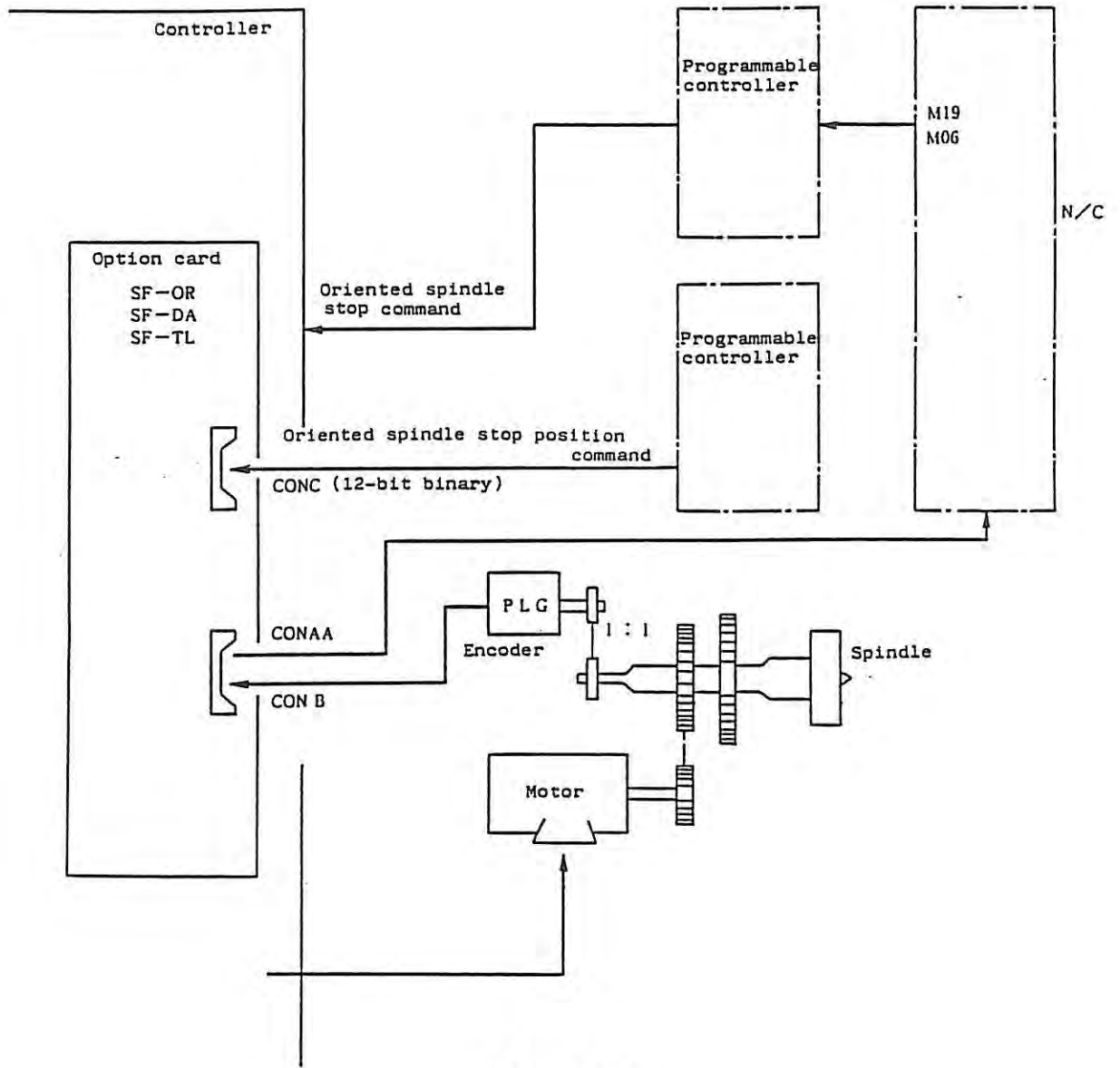
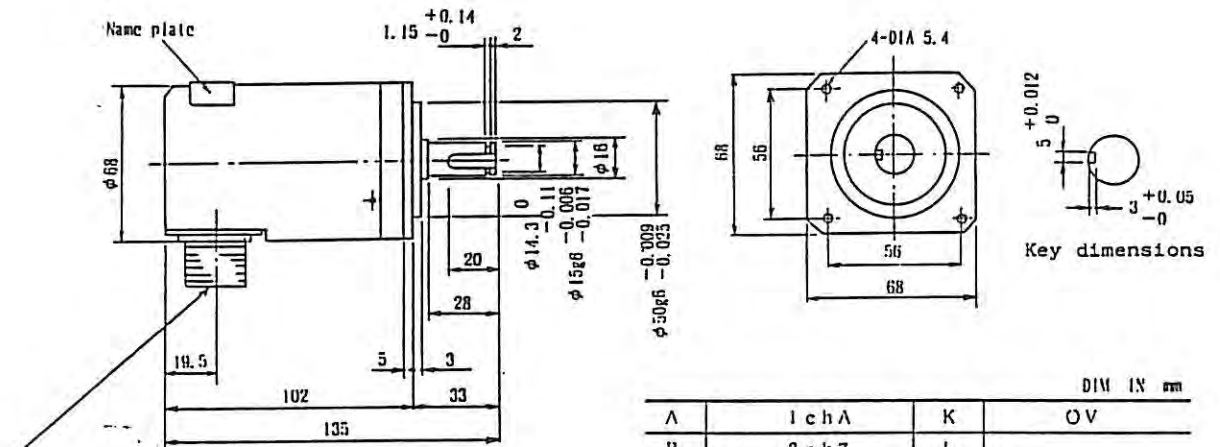

Fig. 6.11

Note: If direction of motor rotation differs from direction of encoder rotation, adjust direction by changing parameter setting.

6.2.4 Outside dimensions

Encoder (1024P/rev) RFH-1024-22-1M-68



Connector
 Encoder: MS3102A20-29P
 Controller cable: MS3106A20-29S (user should prepare this connector)

Note: Max. encoder speed should be less than 6000rpm..

DIM IN mm			
A	1 ch A	K	0V
B	2 ch Z	L	
C	1 ch B	M	
D		N	1 ch A
E	Case earth	P	2 ch Z
F		R	1 ch B
G		S	
H	+5V	T	
J			

§7. PROFILING CONTROL (C-AXIS CONTROL) ENCODER

7.1 Name

Encoder OSE90K+1024 BKO-NC6336H01

7.1.1 Outside dimensions

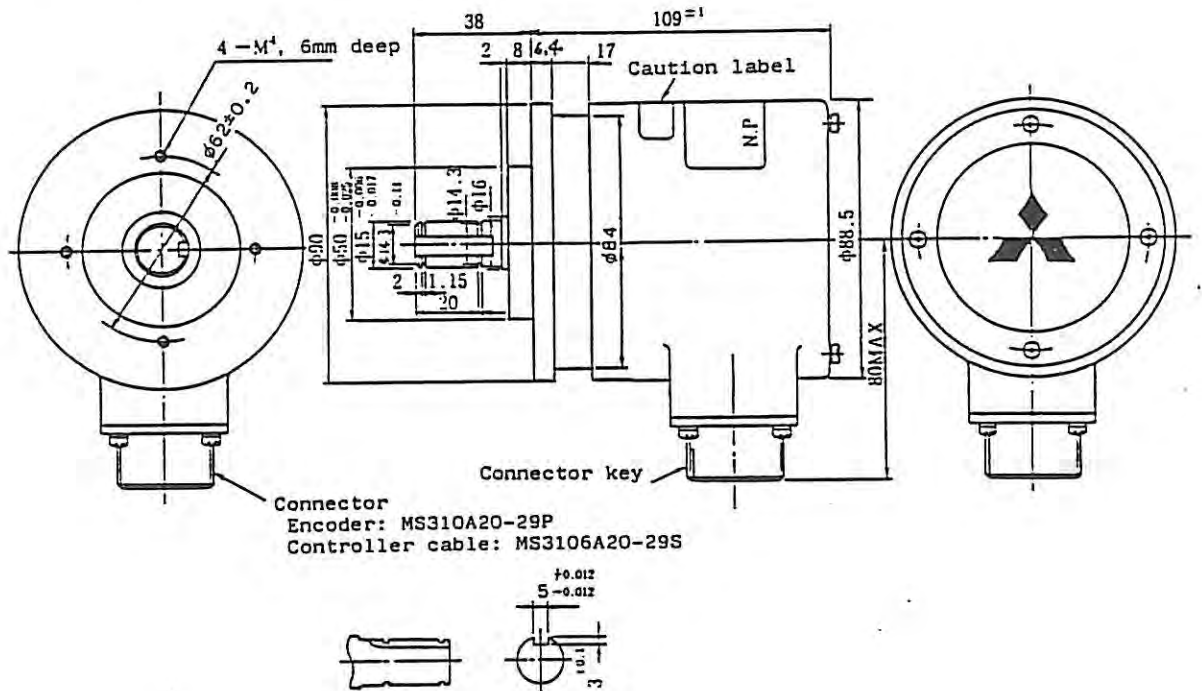

- Notes: 1. Speed of encoder should not exceed 6000rpm.
 2. Tolerance to dimensions should be $\pm 0.5\text{mm}$ unless otherwise specified.

7.1.3 Connectors

(1) Connector: MS3102A20-29P

(2) Connection

	Signal output	Remarks
1 c h	1024 C/T	A.B phase $\bar{A}.\bar{B}$ phase
2 c h	1 C/T	Z phase. \bar{Z} phase
3 c h	90000 C/T	C.D phase, $\bar{C}.\bar{D}$ phase
4 c h	1 C/T	Y phase. \bar{Y} phase

Pin	Function
A	1ch A phase
B	2ch Z phase
C	1ch B phase
D	—————
E	Case GND
F	3ch C phase
G	3ch D phase
H	DC + 5 V $\pm 5\%$ $\pm 10\%$
J	0 V

Pin	Function
K	0 V
L	3ch \bar{C} phase
M	3ch \bar{D} phase
N	1ch \bar{A} phase
P	2ch \bar{Z} phase
R	1ch \bar{B} phase
S	4ch Y phase
T	4ch \bar{Y} phase

Admitted electrical speed is 166rpm for signal in 3 channel (C, D phases, \bar{C} , \bar{D} phases)

7.1.4 Mechanical specifications

(1) Rotational characteristics

- a. Inertia : Max. 100g-cm²
- b. Shaft frictional torque: Max. 1g-cm
- c. Shaft angular acceleration: Max. 10⁵ rad/sec²
- d. Permissible max. speed: 7,030rpm

(2) Mechanical construction

- a. Bearing : Reöiling is not required for 100,000hr of operation at 2,000rpm, and 20,000hr of operation at 6,000rpm.
- b. Shaft runout : Max. 0.2mm at 15mm from shaft end
- c. Permissible load: 10kg (5kg during operation) in thrust direction
20kg (10kg during operation) in radial direction
- d. Weight : Max. 2kg
- e. Error in perpendicularity of flange surface against shaft : Max. 0.05mm
- f. Eccentricity in flange engagement: Max. 0.05mm

(3) Environment

- a. Operating temperature range: -5°C to $+55^{\circ}\text{C}$
- b. Storage temperature range: -20°C to $+85^{\circ}\text{C}$
- c. Humidity : 95%RH (at 45°C) for 8 hours
- d. Vibration : 5 - 50Hz, full amplitude, 30 min. for each axis
- e. Mechanical impact: 30G, 11msec, 10 times for each axis

7.1.5 Handling, installation and operation of encoder

1. Installation of encoder

It is recommended that flexible coupling is used to connect the encoder to the spindle.

- (1) Runout and misalignment in encoder connection should be within the following limitations:

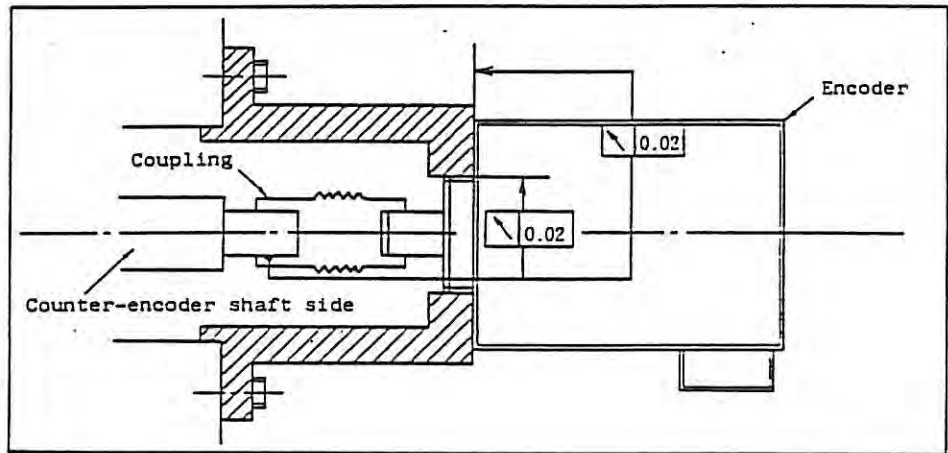

(2) Recommended coupling

	Example 1	Example 2
Manufacturer	TOKUSHU SEIKO	EAGLE
Model	Model M1	FCS38A
Resonance frequency	1,374Hz	3,515Hz
Error in position detection	0.8×10^{-3} deg.	1.2×10^{-3} deg.
Permissible speed	20,000rpm	10,000prm

		Example 1	Example 2
Misalign- ment	Eccen- tricity	0.7mm	0.16mm
	Angular dis- place- ment	1.5deg.	1.5deg.
Outside dimen- sions	Max. length	74.5mm	33mm
	Max. dia- meter	φ57mm	φ38mm

For details, refer to the relevant catalog.

2. In order to assure the maximum performance of encoder, note the following:

(1) Power supply of encoder should be more than 4.5V.

- ① Use wires large enough for +5V and 0V lines.
- ② Use two ore more wires for +5V and 0V lines.
- ③ Use a cable as short as possible (shorter than 8m for cable side of 0.3sq. (100 ohm/km)).

(2) In the connector on the encoder side, short-circuit between pins E and J, or K.

(Use a short wire of 0.75sq. - 1.25sq.)

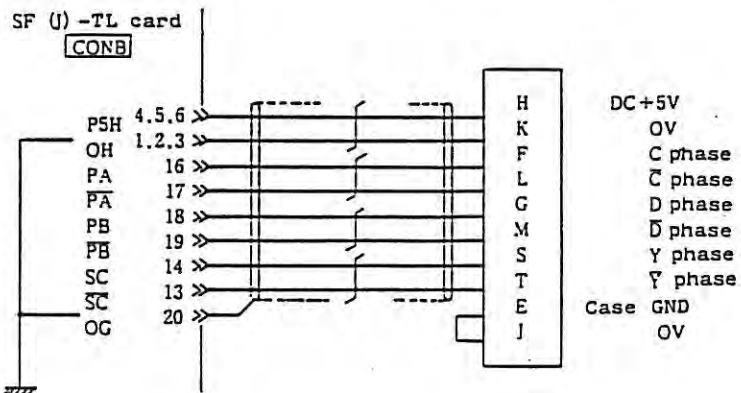

3. Others

- (1) Carefully handle the encoder, avoiding mechanical shock to the encoder.
- (2) Wrong wiring may cause serious trouble. Before wiring

the encoder, carefully identify connector name, pin No., etc. to avoid miswiring.

§8. TROUBLESHOOTING

8.1 General information

If any trouble occurs with the control system, perform the preliminary check described below and then proceed to the troubleshooting described later.

The following preliminary check is very important when you consult with service engineer.

Preliminary check:

1. Was any alarm displayed on the controller?
If yes, identify the cause of alarm.
Also examine previous alarms through the LED readout in "alarm" mode (refer to "Alarm/warning table").
2. If fuse was blown out, identify the phase in which the blown out fuse was used (control circuit power supply fuse).
3. Is the trouble or failure reproducible?
4. Are ambient temperature and panel inside temperature normal?
5. When the trouble occurred (during acceleration, or deceleration, or steady-speed operation)?
What was the speed?
6. Is direction of rotation correct?
7. Did instantaneous power failure not occur?
8. Does the same trouble occur in a specific operation, or when a specific command is given?
9. How frequently occurs the trouble?
10. Does the trouble occur when load is applied, or when load is removed?
11. Was any part replaced or any provisional remedy done?
12. How many years have been used the control system?

13. Is supply voltage normal?

Does it change from time to time?

8.2 First step of troubleshooting

Perform the following check:

(1) Power supply voltage should be $200V_{-15\%}^{+10\%}$, 50/60Hz, or 210V, 210V or $230V_{-15\%}^{+10\%}$.

In any case, it should not go down below -15% of 200V.

o Check if the supply voltage drops at a specific time everyday.

o Check if the supply voltage drops at start of a specific machine in the factory.

(2) Are the peripheral control devices or functions in good condition?

o Are the NC and programmable controller wired properly?

o Visually check cables and other components for condition.

(3) Is temperature inside and outside the control equipment below 55°C ?

(4) Visually check the control equipment.

o Cards, circuit patterns, etc.

o Looseness of wire, damage, foreign matter, etc.

(5) Are all SF-PW DC supply voltages proper?

The most likely troubles or failures with FR-SF can be largely divided into the following two groups:

Trouble A	[Control equipment does not work satisfactorily when it is turned on for the first time (I).
		Control equipment comes into a standstill abruptly (II).
		Control equipment fails from time to time, or error occurs in oriented spindle stop position, or "alarm" lamp lights (III).

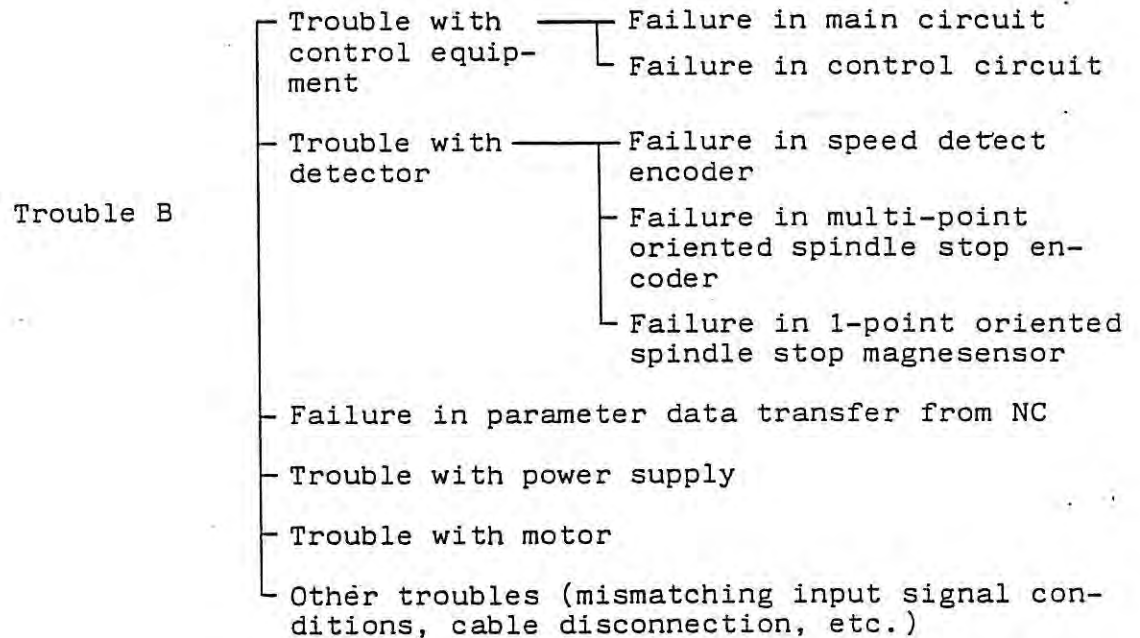

8.3 Second step of troubleshooting

Trouble I	Checkup	Remedy
Control equipment does not work satisfactorily when it is turned on for the first time.	As far as the control equipment is handled carefully, this type of trouble is quite unlikely to occur. The most possible cause is, (1) Mechanical shock or impact was given to the equipment during shipment, installation or handling.	(1) Visually check if any part of the equipment is damaged.
	(2) Wiring is incorrect, or disconnected. <u>Check grounding wire.</u> (It is not required to consider power phase sequence.)	(2) Check that the power indicator LED in SF-PW is on. (Note 1) Check the wiring.

Trouble I	Checkup	Remedy
	(3) Check ROM No. and parameters against the order sheets.	(3) If discrepancy is found, replace ROM or change parameter setting.
	(4) Motor speed cannot be increased.	(4) Interchange motor connection between any two phases (U, V and W).
	(5) No-load operation is in good condition.	(5) Check load condition.
	(6) Only oriented spindle stop function is not in good condition (over-run, etc.)	(6) Readjust.
	(7) "Alarm" lamp lights.	Refer to 7.4.

Note 1: "Start signal CW (CCW)" should be turned on after "READY" signal and "speed reference" signal have been input.

Trouble II	Checkup	Remedy
Control equipment comes into a standstill abruptly	(1) Check if fuse was blown out or main circuit no-fuse breaker was tripped.	(1) Replace blown out fuse. If fuse is blown out again, proceed to "Step III).
	(2) Check the input power supply. AC200V ^{+10%} _{-15%} , 50Hz AC200 - 230V ^{+10%} _{-15%} , 60Hz	(2) Input correct power supply. Provide power supply with sufficient margin in capacity.
	(3) "Alarm" is displayed by the controller.	Refer to 7.4.

Trouble II	Checkup	Remedy
	<p>(4) Are signals from NC and programmable controller proper?</p> <p>Check the input signals (machine "READY", "FWD run", "REV run", etc.), using "diagnosis" function (read-out).</p>	<p>(4) Correct input signal.</p>
	<p>(5) In open-loop control mode,</p> <ul style="list-style-type: none"> o set control parameter to <u>00 0001</u> , ADD DATA o input "speed reference" signal and "start" command to try operation. <p>(Control mode returns to closed-loop mode, when PB1 button is pressed, or the power is turned off after parameter setting.)</p>	<p>(5) If operation becomes possible, it is likely that speed feedback system is in failure..... replace the encoder.</p> <p>If operation is impossible, it is likely that the main circuit is in failure ("alarm" lamp will light).</p>

Trouble III	Checkup	Remedy
<p>Control equipment fails from time to time, or error occurs in oriented spindle stop position.</p> <p>(Condition is restored when the power is turned off and then on to re-set.)</p>	<p>In this case, the comprehensive analysis must be accomplished to determine the cause (load condition, operation mode, etc.).</p>	
	<p>(1) Check if instantaneous power failure occurred or "UNDER VOLTAGE" was displayed.</p>	<p>(1) Check the power supply.</p>
	<p>(2) Check if malfunction occurred in control circuit, due to large noise.</p> <p>The control equipment is capable of withstanding noise (in power supply) of 1600V/1μs.</p>	<p>(2) Determine the noise source and install a surge killer, etc.</p> <p>Check and improve grounding method (particularly, grounding of detector).</p>
	<p>(3) Check if overload occurred due to momentary change of load.</p> <p>Check with particular care if error occurred in oriented spindle stop.</p>	<p>(3) Check mechanisms carefully.</p> <p>Check backlash between spindle and spindle encoder.</p>

8.4 Detailed troubleshooting

8.4.1 "Alarm warning" displayed by LED readout

(1) OVERHEAT, MOTOR

AL004E

OHS1/OHS2 opened

Cause	Checkup	Remedy
Overload	<ol style="list-style-type: none"> 1. Check motor load condition. 2. Start and stop are too frequent. 	<ol style="list-style-type: none"> 1. Lighten motor load. 2. Decrease start and stop frequency.
Fan trouble	<ol style="list-style-type: none"> 1. Check the fan motor. 	<ol style="list-style-type: none"> 1. Remedy or replace the fan.
Motor air filter loaded	<ol style="list-style-type: none"> 1. Check air flow from motor. 	<ol style="list-style-type: none"> 1. Clean the motor air filter.
Thermosensor trouble	<ol style="list-style-type: none"> 1. Allow the motor stopped for several minutes and start again to check. 	<ol style="list-style-type: none"> 1. For provisional remedy, close OHS1/OHS2. 2. Replace the motor.

(2) ERROR EXCESS, SPEED

AL0023

This display occurs if difference between specified speed and true speed is larger than 500rpm, lasting for 12sec. or more.

Cause	Checkup	Remedy
Overload	<ol style="list-style-type: none"> 1. Check motor load condition. 	<ol style="list-style-type: none"> 1. Lighten the load.
Speed detect encoder trouble	<ol style="list-style-type: none"> 1. Check if operation is possible in open-loop mode. 	<ol style="list-style-type: none"> 2. Replace the encoder.

Cause	Checkup	Remedy
Card trouble	1. SF-CA card is defective.	1. Replace the card.

(3) BREAKER TRIP

AL0024

This display appears if the main power no-fuse breaker trips. It may be possible that "IOC" (converter/inverter) appears prior to this display.

Cause	Checkup	Remedy
Power supply voltage below 180V	1. Check if supply voltage decreases during deceleration (regenerative operation).	1. If voltage of line power supply itself is close to 180V, this alarm is likely to occur in transition. Boost the power supply voltage or increase the power supply capacity.
Refer to "IOC trip".		

(4) PHASE LOSS Phase failure

AL0025

This display appears if any phase fails when the power is turned on.

Cause	Checkup	Remedy
Phase disconnected	1. Check voltage in each input phase.	1. Securely connect the power supply cable.
Fuse F1, F2 or F3 blown out	1. Check if there is short-circuiting.	1. Replace the blown out fuse after removal of the cause.

(5) OVER SPEED

AL0031

This display appears if motor speed exceeds 115% of the rated speed.

Cause	Checkup	Remedy
Speed detector trouble	1. Check frequency of encoder output (card CH44, CH45).	1. Replace the speed detector (encoder). Frequency should be $\frac{256 \times 1500}{60} = 6.4\text{kHz}$ at 1500rpm.
Trouble with speed detect circuit/speed reference circuit	2. Speed control card (SF-CA) is defective.	1. Replace the card.

(6) INVERTER, CONVERTER "IOC TRIP"

CONVERTER IOC

AL0025

INVERTER IOC

AL0032

Both the alarms "INVERTER IOC" trip and "CONVERTER IOC" trip are due to overcurrent.

If IOC alarm occurs again after resetting, it is likely that semiconductor in the main circuit is defective.

Cause	Checkup	Remedy
Power transistor damaged	Disconnect the controller from the motor and operate only the controller to see if IOC trip	Replace defective power transistor(s).

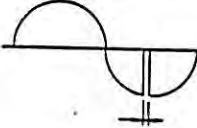
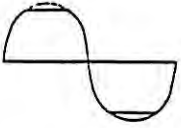
Cause	Checkup	Remedy
	<p>is displayed again.</p> <ul style="list-style-type: none"> o If display appears again, power transistor is defective. o If display does not appear, proceed to the next step. 	
Motor load excessive	Check motor load condition.	Lighten the load.
Motor wiring improper	<p>Check motor wiring.</p> <p>Check motor wiring terminal screws for looseness.</p>	<p>Improve wiring.</p> <p>Retighten loose terminal screws.</p>
Motor winding layer-short-circuit or ground fault	Measure insulation resistance, using a megger (insulation resistance should be larger 1 Megohm).	Replace the defective motor.
Voltage drop	Check power supply voltage (the voltage should be at least 170V during acceleration, deceleration and operation under load).	Use power supply of larger capacity.
Supply voltage waveform	<p>Observe supply voltage waveform on a synchroscope to check that waveform does not change during acceleration and deceleration.</p> <p>1. Partial discontinuation</p>  <p>To be less than 100μs</p> <p>2. Peak is chipped.</p>  <p>To be less than 2 - 3%</p>	<p>Eliminate distortion of waveform</p> <p>1. Increase power supply capacity or use power cable of larger size.</p>

Cause	Checkup	Remedy
Power supply frequency unstable	Frequency variation should be within $\pm 3\%$.	Improve power supply frequency characteristic.
Current detect circuit trouble	<p>Check if failure in current detection occurs at peak voltage of 10V, measured across CH43 and AGA on the inverter side.</p> <p>Check if failure in current detection occurs at peak voltage of 10V, measured across CH39 and AGA on the converter side.</p>	Replace card SF-CA.

(8) OVERHEAT, AMP

AL0 45

This display appears if the controller thermal protector is actuated (for model having cooling fan).

Cause	Checkup	Remedy
Overload	<ol style="list-style-type: none"> 1. Check motor load condition. 2. Start and stop are too frequent. 	<ol style="list-style-type: none"> 1. Lighten the load. 2. Decrease start and stop frequency.
Ambient temperature high	Measure ambient temperature.	If temperature around the controller is over 55°C , use a suitable cooling means.
Fan trouble	Check operation of cooling fan.	Replace the fan.

(9) UNDER VOLTAGE

AL0000

This display appears if voltage under 170V lasts for longer than 15ms.

Cause	Checkup	Remedy
Power supply capacity insufficient	The display appears when speed is changed or load is excessive.	Increase capacity of power supply.
Display appears continuously.	If the input power supply is in good condition, SF-PW is not in good condition. ACDOWN - D05A "H" level when control circuit is in good condition (+5V)	Replace card SF-PW[].

(10) OVER VOLTAGE

AL0033

This display appears if voltage across rectifier capacitor is excessive.

Cause	Checkup	Remedy
Power supply impedance excessive		Increase capacity of power supply.
Instantaneous power failure or voltage drop		Reset to check.
Detector circuit trouble	If the cause cannot be determined by the check described above, it is likely that the detector circuit is defective.	Replace card SF-CA[].

(11) MEMORY ERROR 1

A L 0 0 1 2

This display appears if read from, or write to the memory incorporated in the controller cannot be done successfully.

Cause	Checkup	Remedy
ROM loaded improperly	Visually check that all pins of ROM are put into the socket properly.	Load ROM properly.
Card SF-CA trouble	Check card SF-CA.	Replace the card SF-CA.

(12) MEMORY ERROR 2

A L 0 0 1 5

This display appears if the buffer for bus-linkage with CNC, M300 series, does not function properly.

Cause	Checkup	Remedy
Bus linkage cable defective		Replace the cable.
Card trouble	Check card SF-TL.	Replace the card.

(13) NO SIGNAL SPINDLE ENC

A L 0 0 2 1

This display appears if signal from the encoder is not input correctly.

Cause	Checkup	Remedy
Trouble with encoder or cable	Check signal fed back from encoder, using synchroscope (CH1 - CH3 for card SF-OR, SF-DA and SF-TL)	Replace the defective encoder or cable.
Card trouble	Check card SF-OR, SF-DA and SF-TL.	Replace the defective card.

(14) IC MAC012 ERROR

A L 0 2 2

This display appears if IC, MAC012, does not function properly.

Cause	Checkup	Remedy
Cause	Check card SF-CA.	Replace card SF-CA.

(15) DATA PARITE, DATA TRANSFER ERROR

DATA PARITY

A L 0 3 4

TRANSFER ERROR

A L 0 3 5

The upper display appears when parity error occurs in data communication with CNC, M300 series.

The lower display appears when data transfer to CNI, M300 series.

Cause	Checkup	Remedy
Trouble with terminal resistor	Check the terminal resistor in condition.	Replace the terminal resistor.
Trouble with cable for bus linkaat	Check the cable for bus linkage.	Replace the cable.
Card trouble	Check card SF-TL.	Replace the card.

(16) DATA ERROR, PARAMETER ERROR

DATA ERROR

AL0 35

PARAMETER ERROR

AL0 37

The upper display appears if value of motion command exceeds the maximum limit (when the controller is bus-linked with CNC, M300 series).

The lower display appears if parameter setting exceeds the permissible maximum value (when the controller is bus-linked with CNC, M300 series).

Cause	Checkup	Remedy
Parameter setting not acceptable or programming error	1) Check the parameter settings against the order sheets. 2) Check the program.	1) Set parameter(s) properly. 1) Correct the program.

(17) ERROR EXCESS, POSITION

AL0 52

This display appears if error in positioning is excessively large.

Cause	Checkup	Remedy
Position detector trouble	Check the waveform if signal feedback from the detector (encoder).	Replace the detector (encoder).
Detector select parameter setting error	Check detector select parameter (PLG).	Correct parameter setting (FR-SF)

Cause	Checkup	Remedy
Positioning command constant too small.	Check positioning command constant.	Use larger positioning command constant.

8.4.3 Troubles that are not displayed by LED readout

(1) No alarm display appears and motor does not start

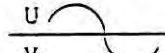
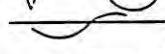
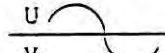
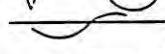
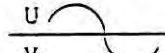
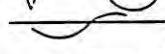
Cause	Checkup	Remedy								
Miswiring or wire disconnection	Check the wiring.	Correct or remedy the wiring.								
Input power supply (voltage) improper	Check the input power supply (200V 50Hz or 200 - 230V 60Hz).	Use the specified power supply.								
Card output voltage improper	Measure output voltage of card SF-PW, using a multimeter.	Replace the card SF-PW, if necessary.								
Trouble with card	<p>Set parameters as follows</p> <table style="margin-left: 40px;"> <tr> <td style="text-align: center;">0 0</td> <td style="text-align: center;">0 0 0 1</td> </tr> <tr> <td style="text-align: center;">ADD</td> <td style="text-align: center;">DATA</td> </tr> </table> <p>In open-loop mode, increase speed reference and see if the correct waveform can be obtained.</p> <p><u>Card SF-CA</u></p> <table style="margin-left: 40px;"> <tr> <td>CH23 - AGA (CH2)</td> <td></td> </tr> <tr> <td>CH14 - AGA (CH2)</td> <td></td> </tr> </table>	0 0	0 0 0 1	ADD	DATA	CH23 - AGA (CH2)		CH14 - AGA (CH2)		If the correct waveform cannot be obtained, replace card SF-CA[].
0 0	0 0 0 1									
ADD	DATA									
CH23 - AGA (CH2)										
CH14 - AGA (CH2)										
Emergency stop or reset signal input from external source		Check the signal wiring.								
Card SF-CA pin 1, 2 setting error	Check if nothing is displayed by LED readout while the control power supply is on.	Correct card SF-CA Pin 1, 2 settings								

(2) No alarm display appears but motor rotates very slowly...

Cause	Checkup	Remedy				
Motor connection improper	Check the motor phase sequence on controller terminals U, V and W.	Wire the motor correctly.				
Input power supply improper.	Check the input power supply.	Use the specified power supply.				
Illegal speed reference signal given from external source	Increase speed reference (input from external source) and see if motor speed increases in accordance with speed reference.	Remedy the external speed reference signal circuit.				
Trouble with speed detect encoder	In open-loop mode, <ul style="list-style-type: none"> o set controller parameter to <table style="margin-left: 40px; border-collapse: collapse;"> <tr> <td style="text-align: center; padding-right: 20px;"><u>00</u></td> <td style="text-align: center;"><u>0001</u></td> </tr> <tr> <td style="text-align: center; padding-right: 20px;">ADD</td> <td style="text-align: center;">DATA</td> </tr> </table> o input speed reference and start command to check if operation is possible. <p>If PB1 is pressed or power is turned off to reset, the control mode changes to "closed loop" mode.</p>	<u>00</u>	<u>0001</u>	ADD	DATA	Replace the encoder if necessary.
<u>00</u>	<u>0001</u>					
ADD	DATA					

(3) Motor does not rotate only within specific speed range

Cause	Checkup	Remedy
External speed reference improper	Check that external speed reference signal voltage linearly changes from 0V to 10V (analog signal input through CH46 and AGA)	Remedy the external speed reference signal circuit.

(4) Motor torque is insufficient

Perform check (1), (2) and (5).

(5) Longer time is required for start

Cause	Checkup	Remedy
Load heavy	Check load condition.	Lighten the load.

(6) Up-to-speed signal is not output (for DIO interface with NC)

Cause	Checkup	Remedy
Trouble with card SF-CA or output circuit	Check that up-to-speed flag (external output in "DIAGNOSIS" mode) turns on at completion of acceleration or deceleration. When flag turns on, the output circuit is defective.	Replace card SF-CA[[]].

(7) Feed motion by NC is impossible

If up-to-speed signal is not output, the corresponding interlock is actuated. Check the control sequence and perform check in accordance with (6).

(8) Speed detect signal is not output (for DIO interface with NC)

Cause	Checkup	Remarks
Trouble with card SF-CA	Check that speed detect flag (external output in "DIAGNOSIS" mode) turns on when speed is faster than preset speed. If the flag turns on, the output circuit is defective.	Replace card SF-CA[[]].

(9) Zero speed signal is not output (for DIO interface with NC)

Cause	Checkup	Remarks
Relay RA1 of card SF-CA defective	Check that zero speed flag (external output in "DIAGNOSIS" mode) turns on when motor speed is slower than 25rpm or 50rpm. If the flag turns on, the output circuit is defective.	Replace card SF-CA

(10) Speed range selection is impossible

Speed range selection is impossible when "speed detect" signal or "zero speed" signal is not given.
Perform check in accordance with (8) and (9).

(11) Speed cannot be increased over a certain speed ...

Check the maximum speed setting.
Check if "override" signal is input.
Check load meter reading..... if meter reading is excessively large, examine load condition.

(12) Intense vibration or large noise occurs

Cause	Checkup	Remarks
Dynamic unbalance		Check dynamic balance.
Insulation resistance decreased	Disconnect the power cable (R, S and T) and measure insulation resistance with a 500V megger (all wires connected to ground terminals should be disconnected). a) Between entire main circuits and ground To be more than 20Megohm (Terminals X1, X2, X3, u, V, W, MS1 and MS2)	If insulation resistance is low, check the circuits to find deteriorated insulation and remedy.

Cause	Checkup	Remarks
	b) Between control circuit COM and ground To be more than 20 Megohm ("OM" of terminal block TB1 of card CA) c) Between entire main cir- cuit and control circuit COM ... To be more than 20 Megohm	
Motor bearing defective	Check that motor can be ro- tated smoothly by hand.	Replace bearing.
Motor mounting screw loosened	Check motor mounting screws for looseness.	Retighten screws.
Runout of motor shaft	Check if motor shaft is damaged.	Remedy or replace motor.
Reference sig- nal waveform irregular	Check that waveforms observ- ed on CH14, CH23 - CH9 (AG) are well-balanced.	Replace card SF-CA.

(13) Speed can be controlled successfully, but spindle cannot be orient-stopped accurately

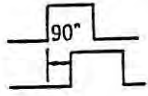
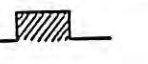
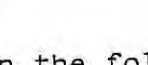
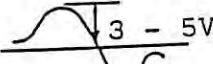
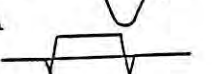
Cause	Checkup	Remarks
<p>Speed is decelerated to oriented spindle stop speed, but spindle does not stop.</p>	<p>Check if positioning control feedback encoder or magnetosensor is in good condition.</p> <p>Run motor under normal speed control to check positioning control feedback signals.</p> <p>Measure voltages on the following check pins of cards SF-OR, DA, AND TL (normal run):</p> <p>CH1 - CH6 (DG) </p> <p>CH2 - CH6 (DG) </p> <p>CH3 - CH6 (DG) </p> <p>(Mark pulse)</p> <p>Measure voltages on the following check pins of card SF-OR, DA, or TL (normal run):</p> <p>CH4 - { SF-CA CH9 (AG)</p> <p> 3 - 5V</p> <p>CON4(16) { SF-CA or CONB(10) { CH9 (AG) </p>	<p>Replace encoder or magnetosensor.</p> <p>Card SF-OR (or SF-DA or TL) interface is defective..... replace the defective card.</p>
<p>In multi-oriented spindle stop, stop position during normal run differs from that during reverse run.</p>	<p>Check backlash of encoder.</p>	
<p>Hunting occurs at spindle stop.</p>	<p>Widen the 1st deceleration range to check.</p> <p>Decrease oriented spindle</p>	<p>Card SF-CA (2nd deceleration range) Parameter #22 PG2</p>

Cause	Checkup	Remarks
	stop speed.	(1st deceleration range) Parameter #21 PG1 (Oriented spindle stop speed)
Spindle stop position depends on gear selected.	Check gear ratio setting. Check parameter settings.	Set gear ratio correctly. If gear ratio has been set correctly, set 1st deceleration range. (PG1) Oriented spindle speed (OSP)
Servo stiffness low	Check gear ratio setting. Check parameter settings.	Increase speed control loop constant (VKP and VKI).
Speed control overshoot		Decrease speed control loop constant (VKP and VKI).

§9. PERIODIC INSPECTION

In order to ensure high-performance operation of equipment, and trouble-free long use of equipment, the periodic inspection is particularly important.

CAUTION: To prevent accident, make sure the power is interrupted completely before starting the inspection.

9.1 Inspection of control equipment

	Frequency	Check	Remedy
1. Cooling fan	Monthly	<ol style="list-style-type: none"> 1. Rotate the fan shaft by hand to check. 2. Turn on the fan to check that the fan runs powerfully. 3. Check if foreign sound occurs in bearing. 	Replace the fan.
2. Soiling, deformation, and terminal screw looseness	Appropriate interval	Check the components for cleanliness, and terminal screws for looseness.	
3. Miniature relays	Every 3 months	<ol style="list-style-type: none"> 1. Check contact points for wear. 2. Check that main circuit contactor opens and closes in accordance with relay operation. 	Replace defective relay(s).
4. Wiring	Appropriate interval	Check if any wire or conductor is short-circuited.	

9.2 Inspection of motor

	Frequency	Check	Remedy
<p>1. Sound (noise) and vibration</p>	<p>Monthly</p>	<p>o Check if foreign sound or intense vibration occurs.</p> <p>If foreign sound or intense vibration occurs, perform the following check:</p> <ol style="list-style-type: none"> 1. Check foundation and installation. 2. Check shaft alignment. 3. Check if vibration is transmitted through shaft coupling. 4. Check if bearing is damaged. 5. Check if noise or vibration is caused by reduction gear or belt. 6. Check control equipment for condition. 7. Check cooling fan for condition. 8. Check belt tension. 	
<p>2. Temperature rise</p>	<p>Monthly</p>	<p>o Check bearing temperature. (Amb. temp. + 10 to 40°C)</p> <p>o Check motor frame temperature.</p> <p>If temperature is high excessively, perform the following check:</p>	<p>Clean.</p>

	Frequency	Checkup	Remarks
		1. Check cooling fan operation. 2. Check cooling air passage (between frame and cover). 3. Check load condition.	
		4. Check control equipment.	Refer to "Troubleshooting".
3. Insulation resistance	Every 6 months	o Check if insulation resistance is excessively low. To check, measure insulation resistance between the entire circuit and ground (control panel disconnected). Insulation resistance should be larger than 1 Megohm, measured by 500V megger. If insulation resistance is less than 1 Megohm, clean and dry motor interior. To dry, disassemble and heat motor at temperature less than 90°C.	
4. Cooling fan	Weekly Monthly	o Check cooling fan for operation, noise and vibration.	

§10. PARTS LIST

AC spindle controller and motor

1. Spare A Spare parts recommended to be replaced every 2 years.
2. Spare B Spare parts recommended to be replaced every 5 years.
3. Spare C Spare parts recommended to be stored by machine manufacturer.

Part No.	Part name	Model		Manufacturer	Symbol	Qty	Spares			Remarks		
							Capacity kW	Standard accessories	Option			
									A		B	C
1	CIRCUIT BREAKER	5.5	NF50CS 3P	40A05	MITUBISHI ELECTRIC	CB1	1	0	0	0	1	
		7.5		50A05								
		11	NF100CS 3P	75A05								
		15		100A05								
		18.5										
		22										
		26										
2	TRAN-SISTOR	5.5	UM75CDY-10		MITUBISHI ELECTRIC	TRR TRS TRT	3	0	0	0	3	
		7.5		UM100CDY-10								
		11	UM150CDY-10									
		15										
		18.5										
		22										
		26										
3	TRAN-SISTOR	5.5	UM75CDY-10		MITUBISHI ELECTRIC	TRU TRV TRW	3	0	0	0	3	
		7.5		UM100CDY-10								
		11	UM150CDY-10									
		15										
		18.5										
		22										
		26										

Part No.	Part name	Model		Manufacturer	Symbol	Qty	Spares			Remarks		
							Capacity kW	Standard accessories	Option			
									A		B	C
4	DIODE STACK	5.5	PT768	NINON INTER	D1	1	0	0	0	1		
		7.5										
		11										
		15	PD608		D1-1	3	0	0	0	3		
		18.5										
		22	PD1008		D1-2							
		26			D1-3							
5	CAPACITOR	5.5	2900UFX350V BKO-NC1043-H19	NIPPON CMEMI-CON	C1-1,2	2	0	0	2	2		
		7.5										
		11										
		15	3200UFX350V BKO-NC1043-H20	NIPPON CONDENSER	C1-1~3	3	0	0	3	3		
		18.5										
		22	C1-1~4								4	0
		26		C1-1~5	5	0	0	5	5			
6	CONTACTOR	5.5	SK50-AC200V	MITUBISHI ELECTRIC	MC1	1	0	0	0	1		
		7.5										
		11										
		15	SK65-AC200V									
		18.5										
		22										
		26										
7	FAN	5.5	N3951ML	TOBISHI	FAN1	1	0	1	0	1		
		7.5										
		11										
		15	HIS4556ML		FAN1 FAN2	2	0	2	0	2		
		18.5										
		22										
		26										

Part No.	Part name	Model		Manufacturer	Symbol	Qty	Spares			Remarks		
							Standard accen-series	Option				
								A	B		C	
8	AC REACTOR	5.5	BKO-NC6321-	H02	CHIUDENKI	ACL	1	0	0	0	1	
		7.5		H03								
		11		H04								
		15		H05								
		18.5		H06								
		22		H07								
		26		H07								
9	CAPACITOR	5.5	MEUZ105K600A BKO-NA1061-05				6	0	0	6	6	
		7.5										C2-R,S,T C3-U,V,W
		11										C2-R,S,T
10	SURGE KILLER	11	BKO-C1916H02	SIZUKI DENKI			3	0	0	0	3	
		15										C3-U,V,W
		18.5										C3-U1,U2
		22										C3-V1,V2
		26										C3-W1,W2
11	SURGE KILLER	15	BKO-C1916H01	SIZUKI DENKI			3	0	0	0	3	
		18.5										C2-R1,R2
		22										C2-S1,S2
		26										C2-T1,T2
12	RESISTOR	5.5	BKO-NC1120-	H02	NICRON DENKI	R1 R2 R3	3	0	0	0	3	
		7.5		H03								
		11		H04								
		15		H05								
		18.5		H06								
		22		H07								
		26		H07								

Part No.	Part name	Model		Manufacturer	Symbol	Qty	Spares			Remarks		
							Capacity kW	Standard accessories	Option			
									A		B	C
13	RESISTOR	5.5	MFS30A802K	MICRON	R0	1	0	0	0	1		
		7.5										
		11			R0-1 R0-2	2	0	0	0	2		
		15										
		18.5										
		22										
		26										
14	RELAY	5.5 26	G4J3342-TDC24V	OMRON	RA1	1	0	0	0	1		
15	RELAY	5.5 26	G4J1142-TDC24V	OMRON	RA2	1	0	0	0	1		
16	THERMAL DETECTOR	5.5 26	OHD-60B	TOOKIN	THS1	1	0	0	0	1		
17	THERMAL DETECTOR	5.5 26	OHD-100B	TOOKIN	THS2	1	0	0	0	1		
18	CT	5.5	BKO- NC6131-	DOOSHIN DENKI	CT1 CT2 CT3 CT4	4	0	0	0	4		
		7.5										
		11										
		15										
		18.5										
		22										
		26										
19	TERNINAL	5.5	TE-K14-3	MITSUBISHI ELECTRIC	TB3	1	0	0	0	1		
		7.5										
		11	TE-K22B-3									
		15										
		18.5	TE-K-D60B									
		22										
		26										

Part No.	Part name	Model		Manufacturer	Symbol	Qty	Spares			Remarks		
							Capac- ity kW	Standard access- ories	Option			
									A		B	C
20	TERMINAL	5.5 26	TE-K2-3	MITSUBISHI ELECTRIC	TB4 TB11	2	0	0	0	2		
21	FILTER	5.5 26	BKO-NC6143H01	SHIZUKI DENKI	FIL1	1	0	0	0	1		
22	FUSE	5.5 26	MF60NR-5A-S	TOYO	F1 F2 F3	3	3	0	0	3		
23	SURGE KILLER	5.5 26	DCR2-12003-5041	MATSUO DENKI	SK1	1	0	0	0	1		
24	PRINTED CIRCUIT BOARD	5.5 26	BKO-NC6233	YAMABISHI	SF-PW	1	0	0	0	1		
25	PRINTED CIRCUIT BOARD	5.5 26	SF-CA (TN990A376G61)	MITSUBISHI ELECTRIC	SF-CA	1	0	0	0	1		
26	OPTION PRINTED CIRCUIT BOARD	—	SF-OR	MITSUBISHI ELECTRIC	SF-OR	1	0	0	0	1		
		—	SF-TL	MITSUBISHI ELECTRIC	SF-TL	1	0	0	0	1		
27	OPTION MAGNETIC- SENSOR	MAGNET	BKO-C1810H03	SONY MAGNESCALE	—	1	0	0	0	1		
			BKO-C1730H06	MACOME	—	1	0	0	0	1		
			BKO-C1730H09									
			BKO-C1730H11									
			BKO-C1730H12									
			BKO-C1730H13									
			BKO-C1730H14									
		SENSOR	BKO-C1810H02	SONY MAGNESCALE	—	1	0	0	0	1		
			BKO-C1730H02	MACOME								
		AMPLI- FIRE	BKO-C1810H01	SONY MAGNESCALE	—	1	0	0	0	1		
BKO-C1730H01	MACOME											
OPTION ROTARY ENCODER	—	RFH1024-22-1M-68	TAMAGAKI SEIKI	—	1	0	0	0	1			

Part No.	Part Name	Model		Manufacturer	Symbol	Q'ty	Spares			Remarks	
		Capac- ity kW					Standard access- ories	Option			
								A	B		C
28	PULSE SIGNAL GENERATOR	—	TS1860N14	TAMAGAWA SEIKI	—	1	0	0	0	1	FOR MOTOR
29	FAN	A90	R6550-7	TOBISHI		1	0	0	1	1	FOR MOTOR
		B90									
		A112									
		B112	IA-15101	UNION SEIKO							
		B132									
		C132									
		A160	PFA-680-A	AKAMATSU ELECTRIC							
		B160									
		B180									
A200	TR300P54-3	TOYO ELECTRIC									
30	BEARING (LOAD SIDE)	A90	606ZZC3	TOYO BEARING		1	0	0	1	1	FOR MOTOR
		B90									
		A112	6307M2ZZCS19								
		B112									
		B132	6310M2ZZCS22								
		C132									
		A160	6312M2ZZCS28								
		B160									
		B180	6314ZZC3								
		A200	6316ZZC3								
31	BEARING (OPPOSITE SIDE)	A90	6006ZZC3	TOYO BEARING		1	0	0	1	1	FOR MOTOR
		B90									
		A112	6306M2ZZCS16								
		B112									
		B132	6308M2ZZCS19								
		C132									
		A160	6310ZZC3								
		B160									
		B180	6312ZZC3								
		A200	6312ZZC3								