

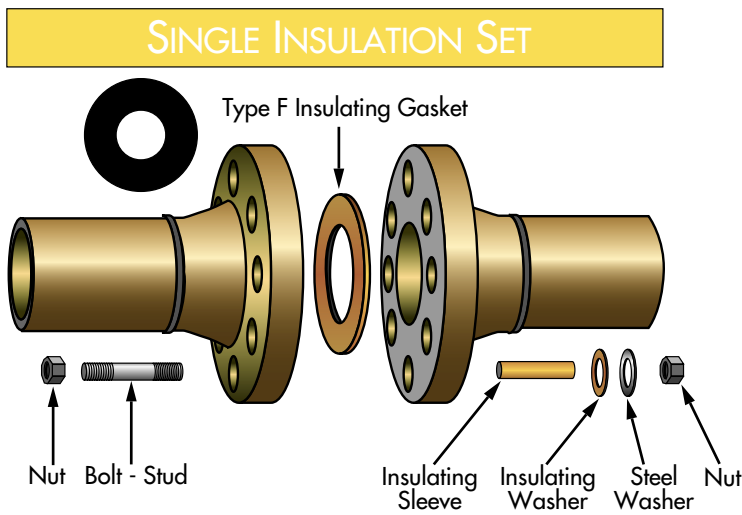

**ADVANCE PRODUCTS & SYSTEMS**  
**FLANGE INSULATING**  
**GASKET KITS**

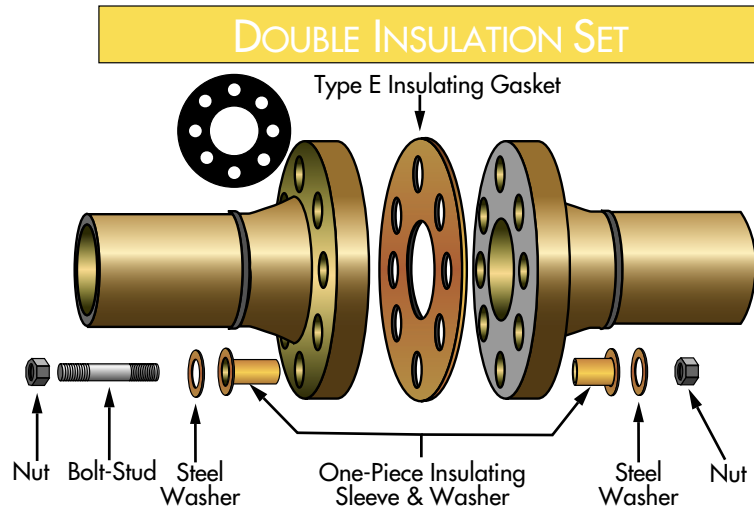

## FLANGE INSULATING GASKET KITS



*Introduction:* With the economic and environmental climate of today it is more important than ever to prevent leakage in your carrier system. Flanges, the most common trouble area, need to be sealed properly to prevent this leakage and must also be cathodically insulated to prevent stray currents which cause undue corrosion and eventual breakdown of the metal.

Advance Products & Systems manufactures and maintains a supply of quality products and materials which can help solve most flange sealing problems to prevent leakage, preventing corrosion, and saving the integrity of the pipeline.



Type	Water Absorption %	Tensile Strength PSI	Compression Strength - PSI	Dielectric Values VPM	Max. Operating Continuous Temp.
CE	1.1	13,000	37,000	600	250° F
G3	0.7	34,000	57,000	700	302° F
G7	.07	20,500	45,000	350	465° F
G10	.09	45,000	65,000	800	285° F
G11	.09	48,000	80,000	530	350° F
AXN	.45	16,000	36,000	600	175° F
AX	.57	16,000	36,000	600	250° F

**TYPE D**

Type D gaskets are specifically designed to fit into the ring groove of ring-type-joint flanges. They are manufactured of a medium weave, fabric-reinforced phenolic material and are sized to ANSI and API specifications - available in basic oval as well as octagonal shape. Also available are BX gaskets with pressure ratings to 15,000 PSI.

**TYPE E**

Type E is a full-faced gasket with the same outside diameter as the flange and precision cut bolt holes. This design facilitates proper alignment of the gasket during installation and foreign material is prevented from shorting the flange insulation. Type E gaskets are available in plain face or Neoprene face phenolic, as well as a variety of high temperature materials.

**TYPE F**

Type F gaskets are made to fit the raised face portion of the flange only. As there are no bolt holes in the F gasket, the inside diameter of the bolt hole circle is slightly smaller than the outside diameter of the gasket, assuring an exact, automatic positioning of the gasket. Available in the same materials as the type E gasket.



## THE TROJAN

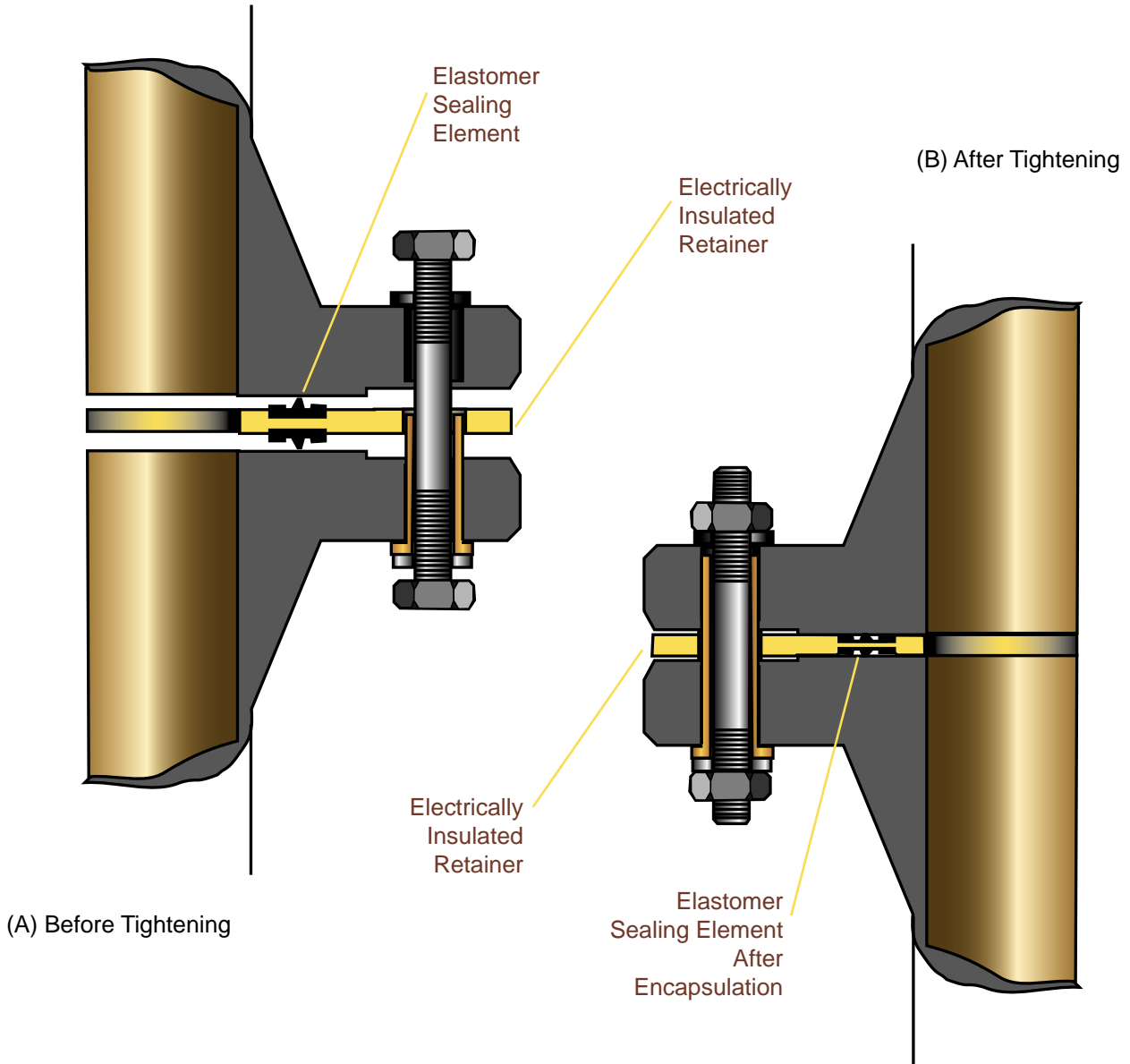

### TROJAN SEALING GASKETS

Trojan gaskets are state-of-the-art in near zero leakage static sealing.

The elastomer sealing element is encapsulated in the electrically insulated retainer. Our most popular sealing element materials are Nitrile® (240°F max. operating temperature), Viton® (400°F), and Teflon® (450°F). The encapsulation of the sealing element permits only micro-exposure of the seal to hostile environs of fire, chemicals and corrosive fluids.

Because the controlled confinement of the elastomer sealing ring within the available volume of the groove in the retainer, 92% to 94% filled volume, a consistent controlled-pressure seal can always be obtained without tremendous bolt loads. Reduced loads allow for reduced flange thickness, smaller bolts and smaller circles.

### ADVANTAGES OF THE TROJAN

- Can be utilized with mismatched flanges
- Can be utilized with misaligned flanges

- Can be used in place of RTJ or BX rings
- Little initial torque required
- No re-torquing required
- Sealing ring cannot be left out
- Seal design tested from 0 -100,000 psi
- Reusable
- Competitive price
- Limited area of seal exposed (long fire life)
- Compensates for pressure fluctuations, compression changes, vibrations, temperature, etc.
- Greatly reduces human error during installation
- Large selection of materials available
- Three to four times the dielectric strength necessary
- Low installation and maintenance costs
- Gaskets through 144"

THE TROJAN

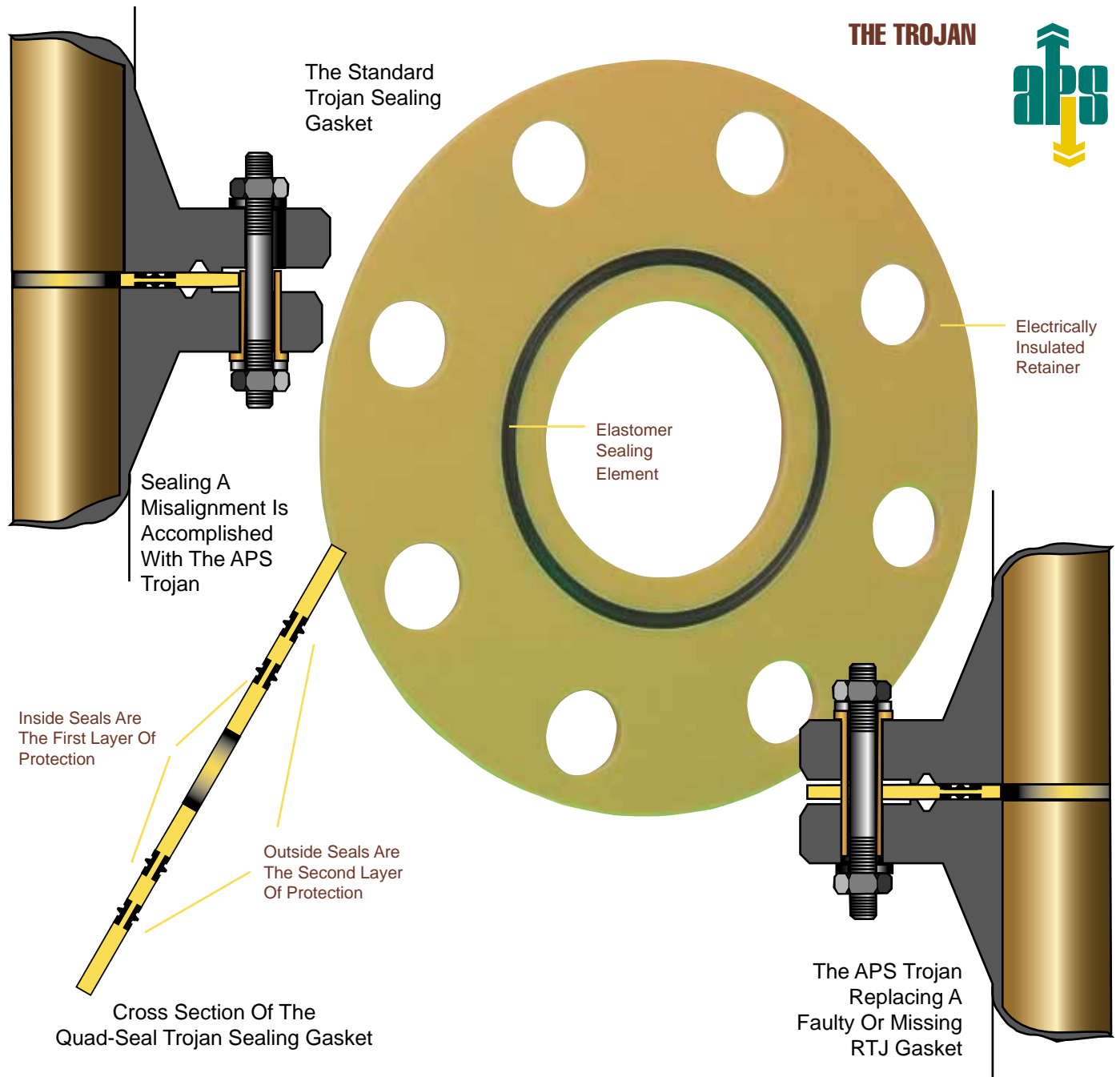

The cross section of APS's Trojan Sealing Gasket (A) shows the elastomer sealing element as it appears before compression between flanges. This compression causes the seal to effectively fill the void of the groove and encapsulate, (B) permitting only micro exposure of the actual seal to hostile elements either from within or without.

### QUAD SEAL TROJAN

Four seals on the new Quad-Seal Trojan further insures the integrity of the sealing capability of an already-proven reliable gasket. For areas where absolute zero leakage is a must, the Quad-Seal Trojan works twice as hard.

All too often, difficult sealing situations arise from mismatched or misaligned flanges. A quick, cost effective solution is the APS Trojan. Also, used in place of damaged or missing RTJ gaskets, the Trojan forms a quick, static seal. The Trojan is often the reasonable alternative to flange replacement.



## INSULATING SLEEVES & WASHERS • FLANGE PROTECTORS



Sleeves & One-piece Sleeve & Washer



### RADOLID PROTECTION CAP

Radolid Protection Caps from APS protect nuts and bolts from destructive corrosion. Caps are easily pressed onto the bolted joints by hand, snapping into place when in position. We recommend loading caps with APS's high melt corrosion inhibitor grease for added protection.



Material	Dielectric Strength volts/mil	Water Absorption %	Max. Continuous Operating Temperature	
			° F	° C
Polyethylene	450	.01	105° F	41° C
Phenolic	400-500	1.1	225° F	107° C
Mylar	4,000	.8	300° F	149° C
Minlon	1,200	.22	250° F	121° C
Nomex	400	-	450° F	232° C
G-10	530	.09	285° F	140° C

### FLANGE PROTECTORS

Kydex and Stainless Steel Flange Protectors and Radolid Protection Caps, two additional ways to further seal flanges from corrosion.

### INSULATING SLEEVES AND WASHERS

Insulating sleeves manufactured of high density polyethylene, NEMA grade LE phenolic, and Mylar are available in a full range of sizes. Also available are one-piece integral sleeves and washers which are made of Minlon, providing superior compression strength. Integral sleeves are available in sizes through 1-1/2". A variety of high temperature sleeves are also

stock items.

With each insulating washer a 1/8" thick S.A.E. electro-plated steel washer is provided to protect the insulating washer from damage by the nut. Advance flange insulation sets are available in single or double washer kits.

### FLANGE PROTECTOR

Advance flange protectors and corrosion inhibitor grease are recommended on all insulated

flanges. By encapsulating the flange cavity with the flange protector and injecting our corrosion inhibitor grease, you can rely on your cathodic protection system to provide you with years of trouble free service.

This system totally eliminates any possibility of foreign material lodging between the faces of your flange or corrosion bridging across and creating a short.



Special Application Gaskets

High Temperature Products



### **HIGH TEMPERATURE PRODUCTS**

**GASKETS:** NEMA grades G3, G7 and G10, Durabla, Durlon, Lydall, JMRD81

**SLEEVES:** Nomex, NEMA grades G7 and G10, Durabla, Durlon

**WASHERS:** NEMA grades G3, G7 and G10, Durabla, Durlon, Lydall

Other high temperature materials are available upon request. It is recommended that the factory be contacted to discuss technical data on the above referenced products.

### **SPECIAL APPLICATION**

Advance Products and Systems, Inc. is well equipped to make those special insulation pads and gaskets sometimes required for odd shaped connections. We can manufacture any configuration or design needed.

These applications include special closures, vaults, steel boxes, special connectors, utility and light poles.

If it needs to be sealed...we can be of service.

### **PACKAGING**

Each Advance flange insulation gasket kit is packaged individually in durable corrugated boxes. Insulating sleeves and washers are packaged separately and are cushioned within the box to protect them from damage during shipment. Each set is clearly tagged with flange size, pressure rating, type of insulating sleeve and whether it is a single washer or double washer set. A recommended bolt tightening sequence is provided with each kit.

**TO ORDER PLEASE SPECIFY THE FOLLOWING**

- Gasket Type D, E or F
- Flange Size and Pressure Rating
- Single Washer or Double Washer Sets (SW or DW)
- Sleeve Material
- Retainer Material
- Sealing Element (Nitrile, Viton or Teflon)

**OTHER PRODUCTS AVAILABLE**

- Advance Flange Band Protectors (Stainless Steel or Plastic)
- Radolid Nut Protective Caps
- Casing Insulators and End Seals
- Specialty Products Manufactured of Phenolic and other materials
- INNERLYNX<sup>®</sup> - Wall/pipe Penetration Seals & Wall Sleeves
- ISOJOINT<sup>®</sup> - Monolithic Insulating Joints
- Foreman Night Caps
- Duocon Centralizers
- Safety Spray Shields
- U-Bolt Cote



**ADVANCE  
PRODUCTS & SYSTEMS, INC.**

P. O. Box 60399  
Lafayette, Louisiana 70596-0399  
337-233-6116  
FAX 337-232-3860  
Email: [sales@advprod.com](mailto:sales@advprod.com)  
Website: [www.advprod.com](http://www.advprod.com)

DISTRIBUTED BY