

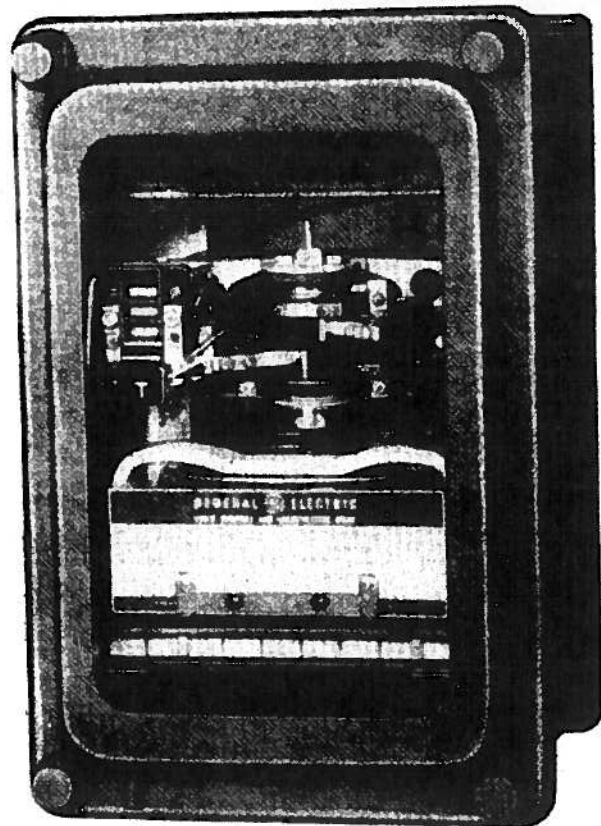

INSTRUCTIONS

GEH-1783J

PHASE SEQUENCE AND UNDERVOLTAGE RELAYS



TYPES

ICR51A ICR53B
ICR53A ICR54A
ICR54B

GENERAL ELECTRIC

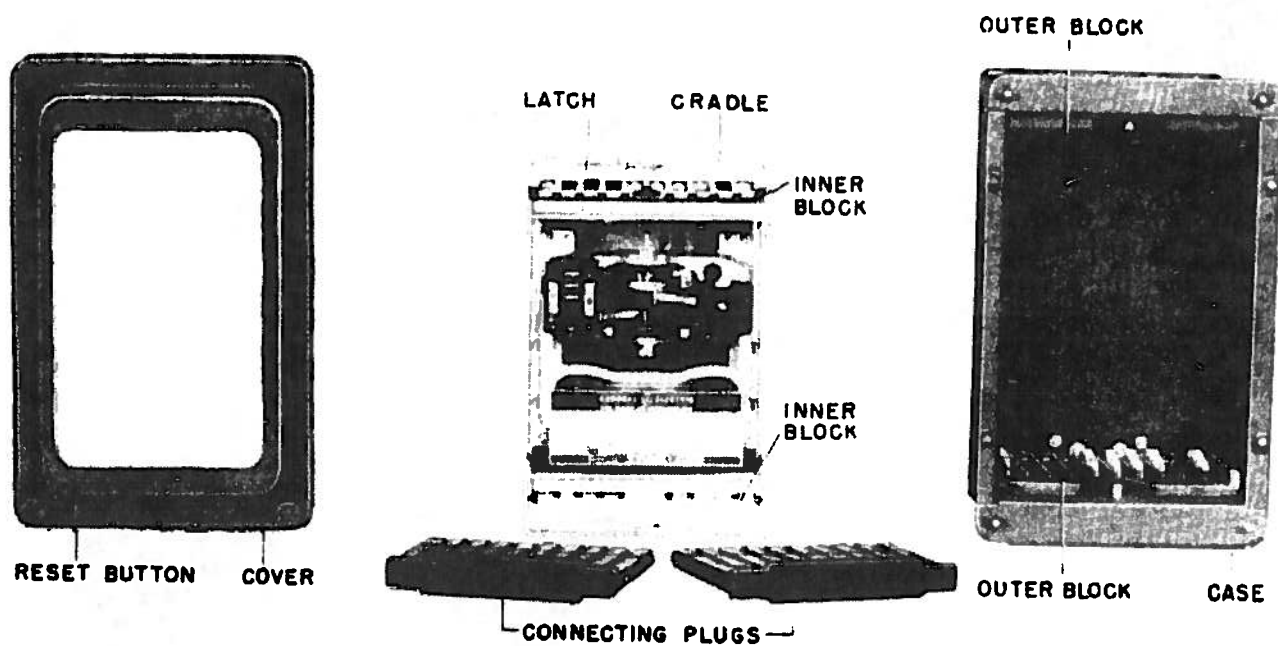

Figure 1 (8014332) Type ICR53A Relay, Unit Disassembled (Front View)

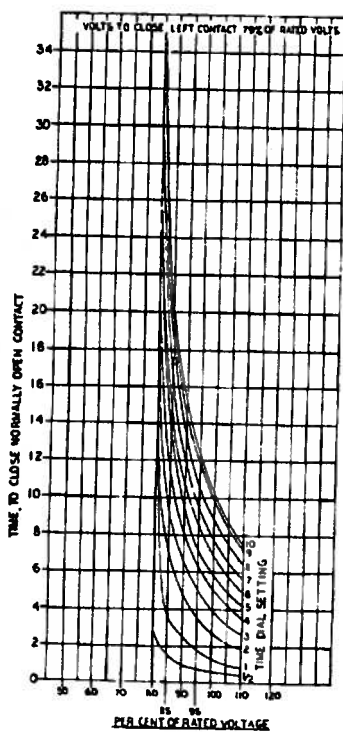

Figure 2A (0203A8302-1) Average Time Characteristic of Relay Type ICR51A

COVER PHOTO (8014333)

PHASE SEQUENCE AND UNDERVOLTAGE RELAYS

TYPE ICR

INTRODUCTION

The Type ICR induction-disk relays are designed to respond to phase-sequence, open-phase and undervoltage.

APPLICATION

The Type ICR relays are used to protect AC machines from undervoltage and when starting from open phase or reverse phase sequence. They will function to stop the machine if the voltage across the relay terminals falls below a predetermined value. Usually these relays will not disconnect a running motor if one phase of the supply is open-circuited because the motor will supply three-phase potential to the relay even with one phase disconnected from the source. The Type ICR relays are also used for automatic throw over schemes where it is desired to check the presence of three-phase voltage of correct phase sequence.

Figures 4 to 6 show typical external connections of the various relay described in these instructions.

TABLE I*

Relay Type	Closing of Open Contact (in % of Rated 3-Phase Voltage)		Closing of Closed Contact (in % of Calibration of Open Contact)		Ave. Time Characteristic Curve
	Range of Adjustment	Factory Setting	Range of Adjustment	Factory Setting	
ICR51A(1)	75 - 100	75	---	--	Figure 2A
ICR51A(2)	75 - 100	90	---	--	Figure 2A
ICR53A	75 - 100	90	75 - 100	89	Figure 2B
ICR53B	75 - 100	90	75 - 100	89	Figure 2B
ICR54A	75 - 100	90	75 - 100	89	Figure 3
ICR54B	75 - 100	90	75 - 100	89	Figure 3

(1) ICR51A1 thru ICR51A11A

(2) ICR51A21A and higher

* Indicates revision

These instructions do not purport to cover all details or variations in equipment nor provide for every possible contingency to be met in connection with installation, operation or maintenance. Should further information be desired or should particular problems arise which are not covered sufficiently for the purchaser's purposes, the matter should be referred to the General Electric Company.

To the extent required the products described herein meet applicable ANSI, IEEE and NEMA standards; but no such assurance is given with respect to local codes and ordinances because they vary greatly.

GEH-1783 Phase Sequence And Undervoltage Relays Type ICR

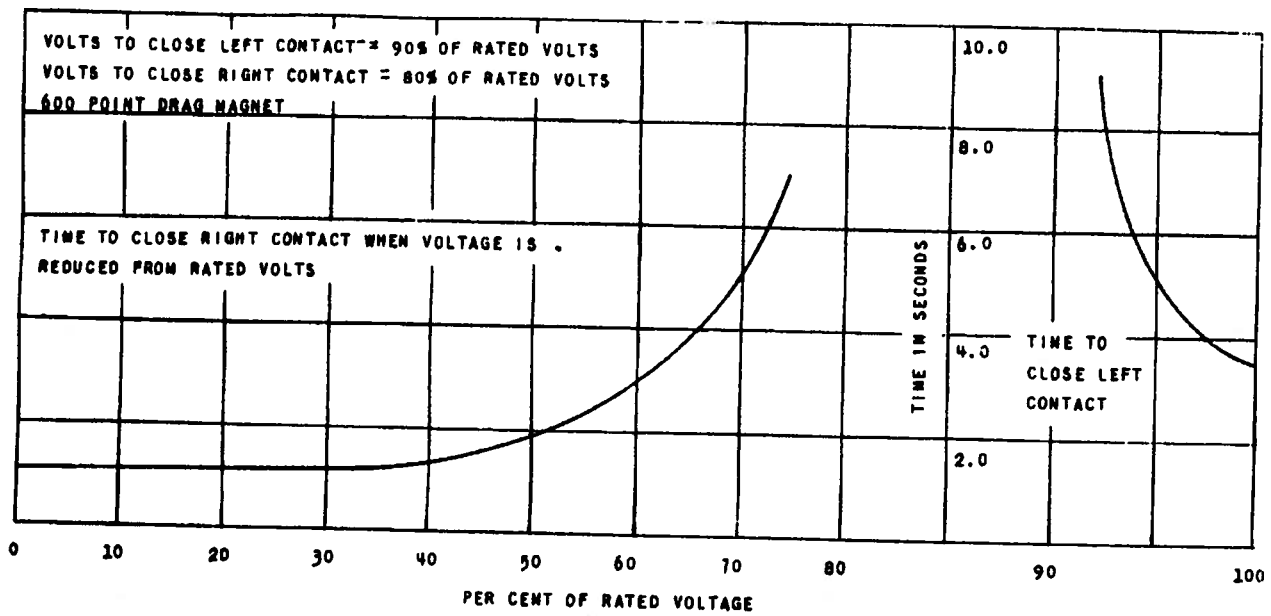

Figure 2B (0376A0950) Average Time Characteristic of Relay Types ICR53A and ICR53B

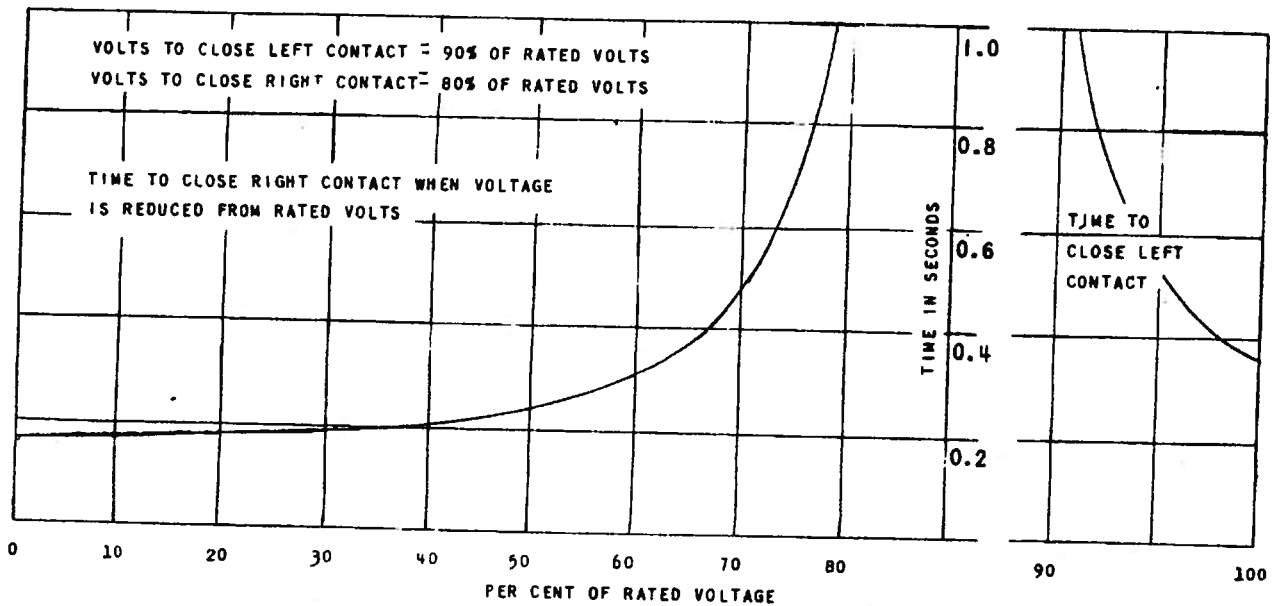

Figure 3 (0376A0949-3) Average Time Characteristic of Type ICR54A Relay

GEH-1783 Phase Sequence And Undervoltage Relays Type ICR

OPERATING CHARACTERISTICS

ADJUSTMENT RANGES AND OPERATING TIME

The range of adjustment and the operating time characteristic references for the various relays are given in Table I. The values of three-phase voltages given are for the proper sequence applied to the relay below which the open contact will open or the closed contact (where used) will close. Unless a specific setting for the relays is given on the requisition, the factory will set the relay for the values shown.

The time characteristic curves referred to in Table I are for factory settings.

RATINGS

The Type ICR relays are available for 120, 240, and 480 volt circuits.

CONTACT RATINGS

The current-carrying rating of the contact circuit is determined by whether the relay has a seal-in unit and by the tap used on the seal-in coil. The values for the three possible arrangements are given in the following table:

Seal-In Unit	No	Yes	Yes
Seal-In Unit Tap	----	0.2 amp	2.0 amps
Carry Continuously	2.0 amps	0.8 amp	3.5 amps
Carry for Trip Duty (250 volt or less)	30 amps	5 amps	30 amps
DC Resistance of Seal-In Coil	----	7 ohms	0.13 ohms
60-Cycle Impedance of Seal-In Coil	----	52 ohms	0.53 ohms

When the contacts of the induction unit are not by-passed by the seal-in unit contacts, they may try to interrupt the circuit. The interrupting rating of the contacts for non-inductive loads are as follows:

Make and Interrupt at:	AC Amps	DC Amps
125 volts	1.50	0.30
250 volts	0.75	0.15
600 volts	0.00	0.00

GEH-1783 Phase Sequence And Undervoltage Relays Type ICR

BURDENS

The burdens imposed by the two potential circuits at rated voltage and 60 cycles are as follows:

Volts	Coil Circuit	Watts	Vars††	VA	PF
120	5 - 6	2.15	4.70	5.20	0.41
120	7 - 8	0.66	2.30	2.40	0.27
240	5 - 6	3.50	13.15	13.3	0.26
240	7 - 8	0.41	6.38	6.40	0.06
480	5 - 6	2.83	23.8	24.0	0.12
480	7 - 8	0.45	23.0	23.0	0.02

††Capacitive

RECEIVING, HANDLING, AND STORAGE

These relays, when not included as a part of a control panel, will be shipped in cartons designed to protect them against damage. Immediately upon receipt of the relay an examination should be made for any damage sustained during shipment. If injury or damage resulting from rough handling is evident, a claim should be filed at once with the transportation company and the nearest Sales Office of the General Electric Company promptly notified.

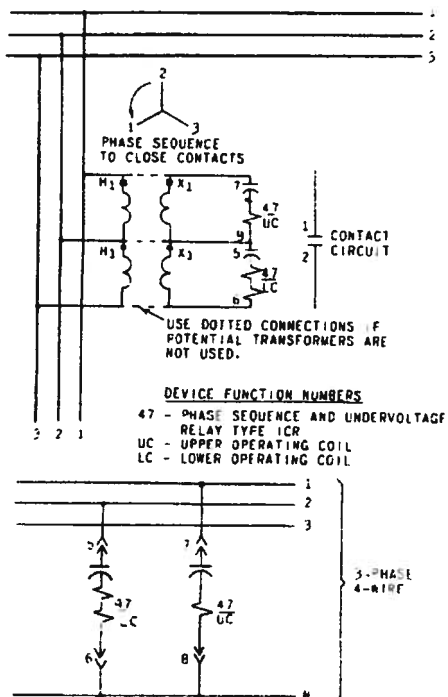

Figure 4 (0376A0947-3) Typical External Connections for Type ICR51A Relay

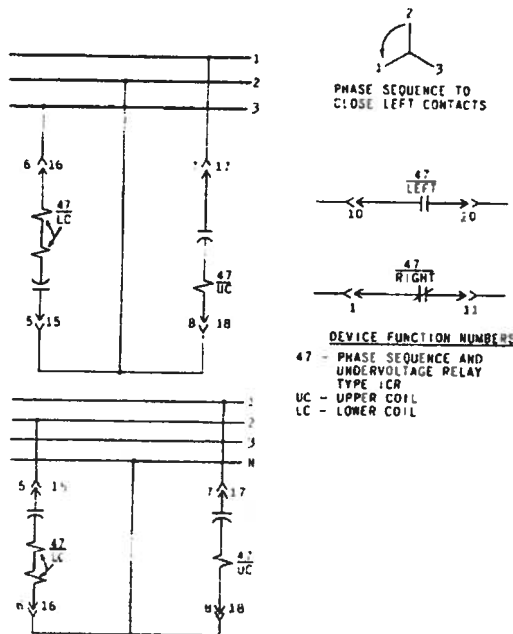

Figure 5 (0376A0953-3) Typical External Connections for Type ICR53B Relay

GEH-1783 Phase Sequence And Undervoltage Relays Type ICR

Reasonable care should be exercised in unpacking the relay in order that none of the parts are injured nor the adjustments disturbed.

If the relays are not to be installed immediately, they should be stored in their original cartons in a place that is free from moisture, dust, and metallic chips. Foreign matter collected on the outside of the case may find its way inside when the cover is removed and cause trouble in the operation of the relay.

DESCRIPTION

The relays covered by these instructions are identified by model numbers. The main constructional differences of these models are given in the following table and are described under RELAY TYPES.

Model	Contacts	Time Dial	Seal-In Unit	Int. Conn.
12ICR51A(-)A	One Open	Yes	No	Figure 7
12ICR53A(-)A	Double Throw	No	Yes	Figure 8
12ICR53B(-)A	Double Throw	No	No	Figure 9
12ICR54A(-)A	Double Throw	No	Yes	Figure 8
12ICR54B(-)A	Double Throw	No	No	Figure 9

RELAY TYPES

The Type ICR51A relay was designed for use in three-phase circuits. It has a single circuit-closing contact which opens on undervoltage or reversed-phase sequence, and a time dial for adjusting the time delay with which the contacts close. The relay does not contain a target.

When the relay is adjusted to open its contacts at 75% of rated voltage, the time required to close the contact with rated voltage applied and the time dial set on number 10 is 10 seconds.

The Type ICR53A relay was designed for use in three-phase circuits. It has double-throw, single-pole contacts. The left-hand contacts open on undervoltage or reverse phase sequence. The relay has a target and seal-in unit which is in series with its closed contact. The relay does not contain a time dial.

When the relay is adjusted for 90% pickup and 80% dropout, the time required to close the normally-closed contacts, when the voltage is suddenly dropped from rated voltage to zero (0) volts, is 1.2 seconds.

The Type ICR53B relay is similar to the Type ICR53A relay except that the target and seal-in unit is omitted.

GEH-1783 Phase Sequence And Undervoltage Relays Type ICR

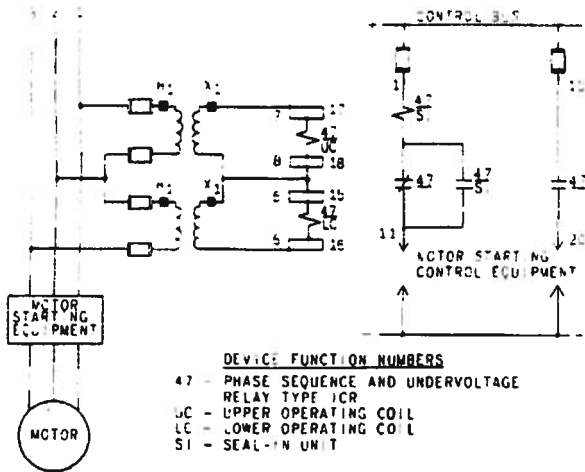

Figure 6 (0376A0951-2) Typical External Connections for Relay Types ICR53A and ICR54A

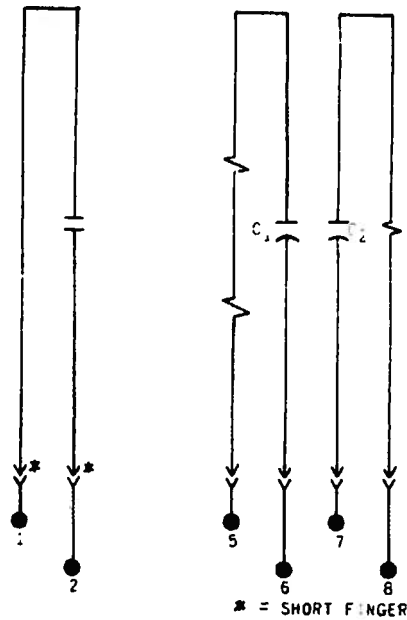

Figure 7 (0362A0629-2) Internal Connections for Type ICR51A Relay (Front View)

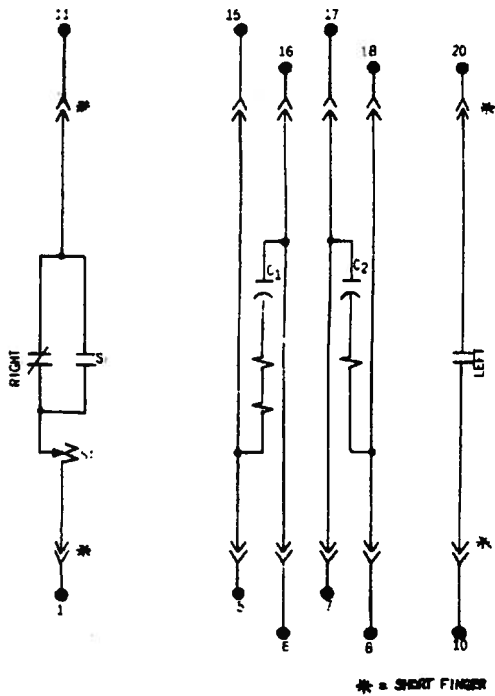

Figure 8 (0362A0633-4) Internal Connections for Relay Types ICR53 and ICR54A (Front View)

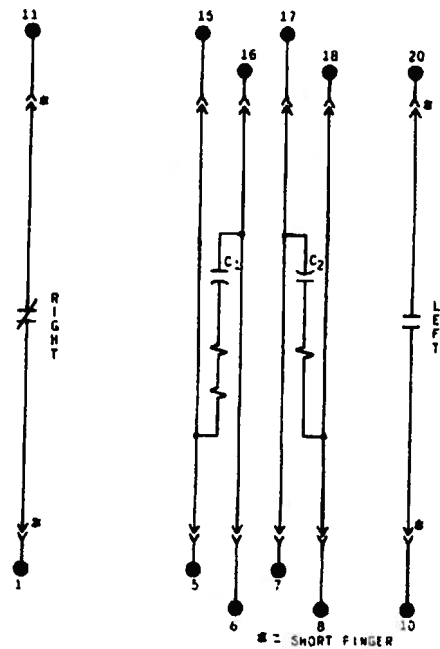

Figure 9 (0362A0634-4) Internal Connections for Type ICR53B and ICR54B Relays (Front View)

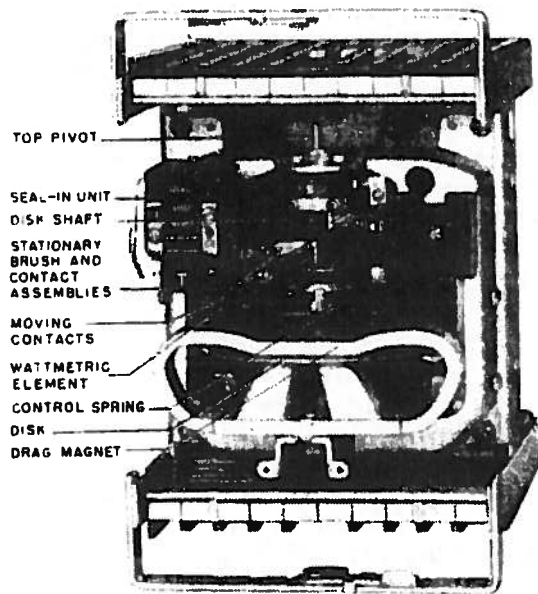

Figure 10 (8014330) Type ICR53A Relay, Unit in Cradle (Front View)

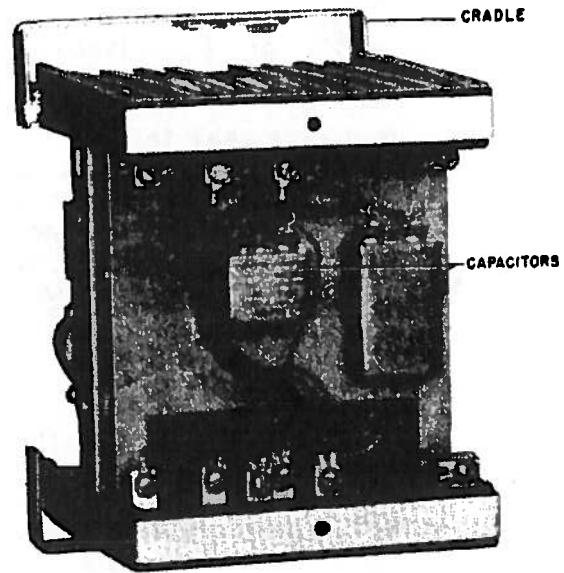

Figure 11 (8014331) Type ICR53A Relay, Unit in Cradle (Rear View)

The Type ICR54A relay is similar to the Type ICR53A relay except that it has faster operating times. When the relay is adjusted to pick up at 90% and drop out at 80% of rated voltage, the time required to close the normally-closed contact when the voltage instantaneously drops from rated voltage to zero volts is 0.17 second.

The Type ICR54B is similar to the Type ICR54A relay except that the target and seal-in unit is omitted.

Relay Types ICR53A, ICR53B, ICR54A, and ICR54B contain a contact that is closed when the relay is de-energized. For this reason, these relays are supplied in double-end drawout cases. The external connections are such that the relay coils are energized when either the upper or lower connection plug is put in place. The relay will therefore have time to open its closed contact before the second connection plug can be put in place. It is necessary to have both plugs in place before the contact circuits are completed.

INTERNAL CONSTRUCTION

The operating unit is similar to that used in a standard watt-hour meter, except that the current coil is replaced by a second potential coil. The induction disk (Figure 10) is embossed to ensure flatness and to give increased rigidity.

The damping magnet consists of a pair of alnico magnets enclosed in a steel circuit. It is mounted by clamp screws on a shelf along which it can be moved for time adjustments.

The relays have high pressure, silver-to-silver contacts. The fixed contacts are adjustable and movable contact direct acting.

GEH-1783 Phase Sequence And Undervoltage Relays Type ICR

The upper bearings consist of a polished steel pin and a bronze guide bearing. It provides a definite alignment of the relay shaft. The lower bearing consists of a polished steel pivot that is carried by a jewel bearing. The jewel is seated on a spring which minimizes shock.

When used, the seal-in unit is mounted to the left of the shaft as shown in Figure 10. This unit has its coil in series and its contacts in parallel with the main contacts such that when the main contacts close, the seal-in unit picks up and seals in. When the seal-in unit picks up, it raises a target into view which latches up and remains exposed until released by pressing a button beneath the lower left corner of the cover.

CASE

The case is suitable for either surface or semiflush panel mounting and an assortment of hardware is provided for either mounting. The cover attaches to the case and also carries the reset mechanism when one is required. Each cover screw has provision for a sealing wire.

The case has studs or screw connections at both ends or at the bottom only for the external connections. The electrical connections between the relay units and the case studs are made through spring backed contact fingers mounted in stationary molded inner and outer blocks between which nests a removable connecting plug which completes the circuits. The outer blocks, attached to the case, have the studs for the external connections, and inner blocks have the terminals for the internal connections.

The relay mechanism is mounted in a steel framework called the cradle and is a complete unit with all leads being terminated at the inner block. This cradle is held firmly in the case with a latch at the top and the bottom and by a guide pin at the back of the case. The cases and cradles are so constructed that the relay cannot be inserted in the case upside down. The connecting plug, besides making the electrical connections between the respective blocks of the cradle and case, also locks the latch in place. The cover, which is fastened to the case by thumbscrews, holds the connecting plug in place.

To draw out the relay unit the cover is first removed, and the plug drawn out. Shorting bars are provided in the case to short the current transformer circuits. The latches are then released, and the relay unit can be easily drawn out. To replace the relay unit, the reverse order is followed.

INSTALLATION

LOCATION

The location should be clean and dry, free from dust and excessive vibration, and well lighted to facilitate inspection and testing.

MOUNTING

The relays should be mounted on a vertical surface. The outline and panel drilling dimensions are shown in Figures 13 and 14.

CONNECTIONS

The internal connection diagrams are shown in Figures 7, 8, and 9. Typical wiring diagrams are shown in Figures 4 to 6.

One of the mounting studs or screws should be permanently grounded by a conductor not less than No. 12 B&S gage copper wire or its equivalent.

INSPECTION

At the time of installation, the relay should be inspected for tarnished contacts, loose screws, or other imperfections. If any trouble is found, it should be corrected in the manner described under **MAINTENANCE**.

ADJUSTMENTS

PICKUP

The magnitude of voltage above which the open contact will be closed is determined by the setting of the lower control spring. To calibrate the relay to operate at a desired value of voltage, apply the desired pick-up value of voltage to the relay and adjust the lower control spring until the left contact just closes. The lower control spring is adjusted by inserting the blade of a screwdriver in one of the notches in the periphery of the control-spring adjusting ring and turning the adjusting ring counter-clockwise to raise the pickup or clock wise to lower the pickup.

DROPOUT

For Relay Types ICR53A, ICR53B, and ICR54A, the magnitude of voltage below which the closed contact will be closed is determined by the contact gap and the pick-up setting. After the pick-up setting is made as described above, the contact gap is adjusted by loosening the two lock screws in the clamp bar located at the top of the shaft. The moving contact of the closed contact is connected to this clamp bar and can be turned relative to the moving contact of the open contacts. The lead-in spring for the upper moving contact is also connected to this clamp bar; therefore, changing the position of the upper clamp bar will change the pick-up setting slightly. This can be reset by changing the lower control spring as described above. When both pickup and dropout are set to the desired value, the locking screws of the top clamp bar should again be tightened.

GEH-1783 Phase Sequence And Undervoltage Relays Type ICR

TIME SETTING

On the Type ICR51A relay, the time required for the open contact to close when rated voltage is applied to the relay determined by the time-dial setting. The maximum time setting is obtained when the time dial is set on the number 10 time-dial setting. The time on any other time-dial setting is approximately proportional to the time-dial setting. For example, the time to close the contacts when set at the number 5 time-dial setting is approximately one-half the time required to close the contacts when set at the number 10 time-dial setting.

For relay Types ICR53A, ICR53B, and ICR54A, the time required to close the contacts is a function of the pick-up and drop-out settings. It is possible to set any two of the three variables. For instance, if the pick-up value and the drop-out time are important, then the pick-up value can be set as given above. The drop-out time can be adjusted by adjusting the contact gap until the desired drop-out time is obtained. The value of drop-out voltage will be determined by the gap setting that was made to get the drop-out time. The value of the drop-out voltage cannot be changed without changing the drop-out time.

Typical test connections are shown in Figure 12.

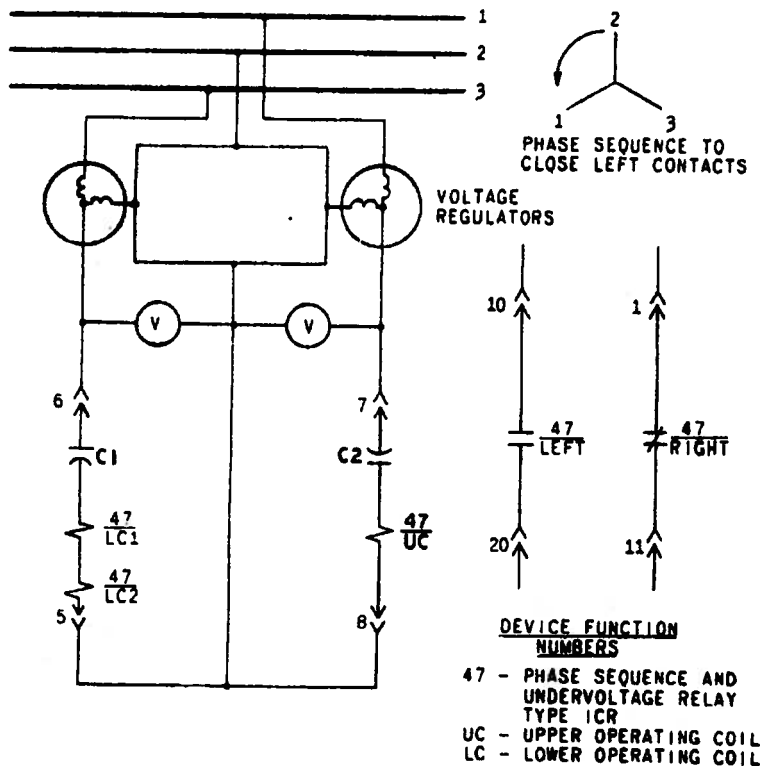

Figure 12 (0376A952-3) Typical Test Connections for Type ICR Relays

TARGET AND SEAL-IN UNIT

For trip coils operating on currents ranging from 0.2 up to 2.0 amperes at the minimum control voltage, set the target and seal-in tap plug in the 0.2-ampere tap.

For trip coils operating on currents ranging from 2 to 30 amperes at the minimum control voltage, place the tap plug in the 2 ampere tap.

The tap plug is the screw holding the right-hand stationary contact of the seal-in unit. To change the tap setting, first remove the connecting plug. Then, take a screw from the left-hand stationary contact and place it in the desired tap. Next remove the screw from the other tap, and place it in the left-hand contact. This procedure is necessary to prevent the right-hand stationary contact from getting out of adjustment. Screws should not be in both taps at the same time as pickup for DC will be the higher tap value and AC pickup will be increased.

OPERATION

These relays are of the induction-disk construction. The disk is actuated by a wattmetric type operating unit. Voltage coils are located above and below the operating disk. Phase shift is provided in each coil by a series capacitor to produce a split-phase field which develops torque on the induction disk.

The torque produced by the Type ICR relay is proportional to the product of the two voltages applied to its two potential circuits and the sine of the angle between the two applied voltages. This relationship makes the torque of the relay proportional to the area of the voltage triangle. The relay will operate when the area of the voltage triangle is a predetermined value. The relay will operate even though this area is reduced to this value due to one phase being low or whether all three phases are low.

MAINTENANCE

DISK AND BEARINGS

The lower jewel may be tested for cracks by exploring its surface with the point of a fine needle. The jewel should be turned up until the disk is centered in the air gaps, after which it should be locked in this position by the set screw provided for this purpose.

CONTACT CLEANING

For cleaning fine silver contacts, a flexible burnishing tool should be used. This consists of a flexible strip of metal with an etch-roughened surface, resembling in effect a superfine file. The polishing action is so delicate that no scratches are left yet corroded material will be removed rapidly and thoroughly. The flexibility of the tool ensures the cleaning of the actual points of contact. Sometimes an ordinary file cannot reach the actual points of contact because of some obstruction from some other part of the relay.

GEH-1783 Phase Sequence And Undervoltage Relays Type ICR

Fine silver contacts should not be cleaned with knives, files, or abrasive paper or cloth. Knives or files may leave scratches which increase arcing and deterioration of the contacts. Abrasive paper or cloth may leave minute particles of insulating abrasive material in the contacts and thus prevent closing.

PERIODIC TESTING

An operation test and inspection of the relay at least once every six months are recommended. Test connections are shown in Figure 12.

RENEWAL PARTS

It is recommended that sufficient quantities of renewal parts be carried in stock to enable the prompt replacement of any that are worn, broken, or damaged.

When ordering renewal parts, address the nearest Sales Office of the General Electric Company, specify the quantity required, the name of the part wanted, and give the complete nameplate data, including the serial number. If possible, give the General Electric Company requisition number on which the relay was furnished.

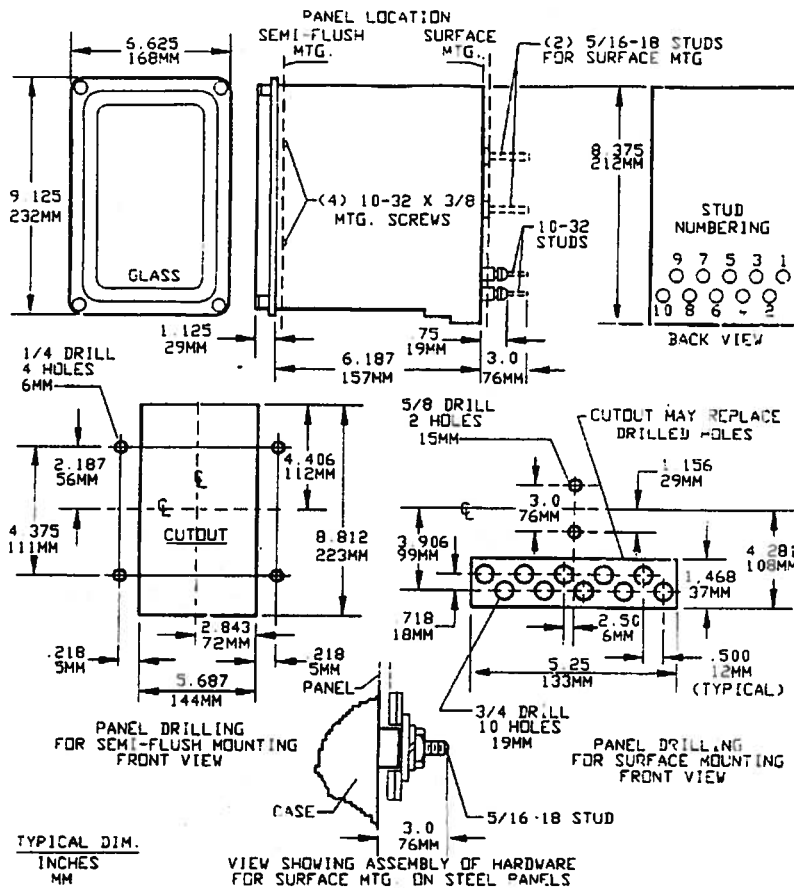

*Figure 13 (K-6209271 [8]) Outline and Panel Drilling Dimensions for the Type ICR51A Relay

* Indicates revision

GEH-1783 Phase Sequence And Undervoltage Relays Type ICR

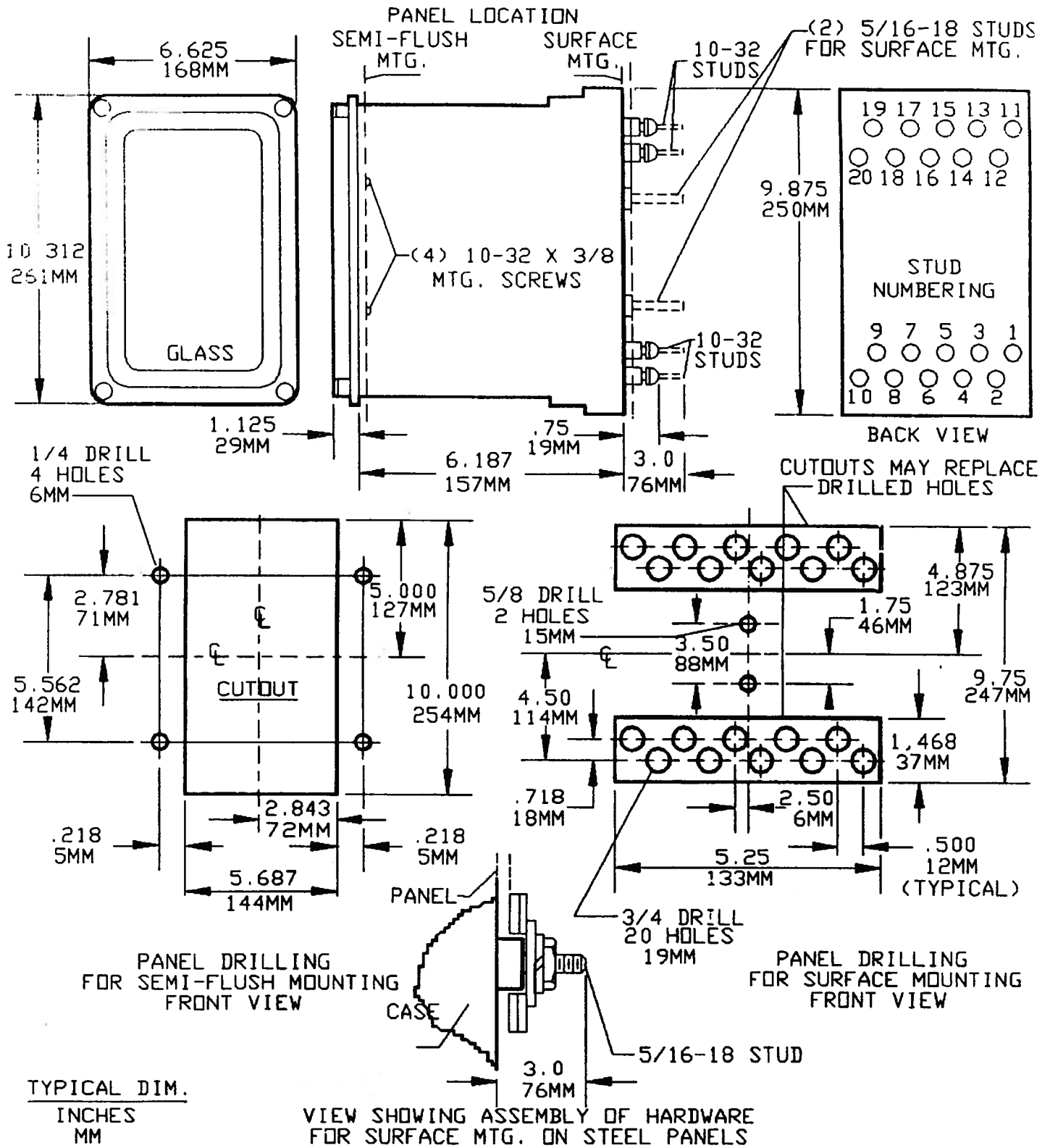

*Figure 14 (K-6209272 [7]) Outline and Panel Drilling Dimensions for Relay Types ICR53A, ICR53B, and ICR54A

* Indicates revision



GE Power Management

**215 Anderson Avenue
Markham, Ontario
Canada L6E 1B3
Tel: (905) 294-6222
Fax: (905) 201-2098
www.ge.com/indsys/pm**