

CHAPTER 10

CONCRETE DECKS

TABLE OF CONTENTS

10.1	INTRODUCTION.....	10-1
10.2	CONCRETE DECK TYPES.....	10-1
10.2.1	Cast-In-Place Concrete Decks.....	10-1
10.2.2	Precast Concrete Decks.....	10-2
10.3	DESIGN APPROACH.....	10-2
10.3.1	Structural Behavior of Concrete Decks.....	10-2
10.3.2	Limit State.....	10-3
10.3.3	Methods of Analysis.....	10-4
10.4	DESIGN CONSIDERATIONS.....	10-6
10.5	DETAILING CONSIDERATIONS.....	10-6
10.5.1	Reinforcement Details.....	10-6
10.5.2	Skewed Decks.....	10-7
10.5.3	Deck Drains and Access Openings.....	10-8
10.6	DESIGN EXAMPLE – REINFORCED CONCRETE BRIDGE DECK.....	10-8
10.6.1	Concrete Deck Data.....	10-8
10.6.2	Design Requirements.....	10-9
10.6.3	Determine Minimum Deck Thickness and Cover.....	10-9
10.6.4	Compute Unfactored Dead Load Moments.....	10-9
10.6.5	Compute Unfactored Live Load Moments.....	10-10
10.6.6	Calculate the Factored Design Moments.....	10-11
10.6.7	Positive Flexure Design.....	10-12
10.6.8	Negative Flexure Design.....	10-14
10.6.9	Check for Crack Control under Service Limit State.....	10-16
10.6.10	Minimum Reinforcement.....	10-18
	NOTATION.....	10-21
	REFERENCES.....	10-23



This page is intentionally left blank.

CHAPTER 10

CONCRETE DECKS

10.1 INTRODUCTION

Bridge decks are an integral part of the bridge structure by providing the direct riding surface for motor vehicles. In addition, bridge decks directly transfer load from the moving traffic to the major load-carrying members. This chapter provides a general description of the various concrete deck types, a discussion of the basic structural behavior of concrete decks, and an overview of major design and detailing considerations. Finally, a design example for a reinforced concrete bridge deck is provided. The example illustrates bridge deck design in accordance with the *AASHTO LRFD Bridge Design Specifications* (AASHTO 2007) and California Amendments (Caltrans 2008a).

10.2 CONCRETE DECK TYPES

There are two main types of concrete decks, cast-in-place, and precast. The most common type used in Caltrans is the cast-in-place reinforced concrete deck. The other type is used depending on the various conditions like location, traffic, cost, seismicity schedule, and aesthetics (Chen and Duan 1999).

10.2.1 Cast-In-Place Concrete Decks

A cast-in-place concrete deck is a thin concrete slab, either using normal reinforcement or prestressing steel, usually between 7 and 12 inches, with reinforcing steel interspersed transversely and longitudinally throughout the slab. There are several advantages to using a reinforced concrete deck. One of the major advantages is its relatively low cost. Other advantages are ease of construction and extensive industry use.

Even though cast-in-place concrete decks have advantages, there are disadvantages using this particular type of deck, such as cracking, rebar corrosion, and tire noise. A large cost of bridge maintenance is in maintaining the riding surface (Fu, et al, 2000). Lack of deck crack control can lead to rebar corrosion and increased life cycle cost, not to mention a poor riding surface for the public.

10.2.2 Precast Concrete Decks

Precast concrete decks consist of either precast reinforced concrete panels or prestressed concrete panels. These panels can either serve as the final deck surface or as a temporary deck to allow placement of a final cast-in-place concrete deck. The advantage of a precast concrete deck is in the acceleration of the construction schedule. Precast panels allow for quicker placement, which, in principle, speeds up overall bridge construction.

10.3 DESIGN APPROACH

10.3.1 Structural Behavior of Concrete Decks

It is accepted and widely known that the primary structural behavior of a concrete deck is not pure flexure, but a complex behavior known as internal arching. Concrete slabs behave quite differently than concrete beams under a given load. Research has shown that when a concrete slab starts to crack, the load is initially resisted by a combination of flexure stresses and membrane stresses as shown in Figure 10.3-1 (Csagoly, et al 1989). The stresses and strain create cracks in three dimensions around the wheel footprint. The way internal arching works is as cracks develop in the bottom of the slab and the slab's neutral axis shifts upward, compressive stresses develop above the neutral axis to resist further opening of the cracks. The concrete portion above the crack is in a purely elastic state. Therefore, what results is a domed shaped compression zone around the load.

The compressive membrane stresses do not resist the loading completely. There is a small flexural component that also resists the loading as well. But the controlling structural mechanic is the membrane compressive stresses created in the upper parts of the slab.

For the deck to fail, as the load is increased the deflection also increases. The section around the load becomes overstrained and this results in a cone-shaped section of failed concrete. Therefore, the primary failure mode is punching shear.

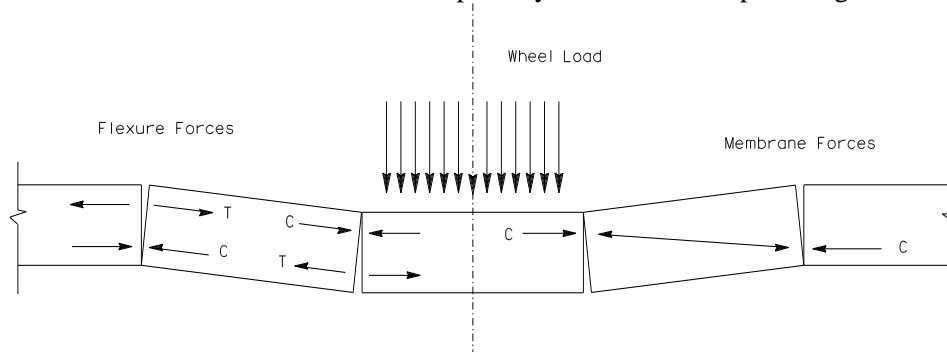

Figure 10.3-1 Concrete Deck Showing Flexure and Membrane Forces.

10.3.2 Limit State

10.3.2.1 Service Limit State

Concrete decks are designed to meet the requirements for Service I limit state (AASHTO 9.5.2). Service limit state is used to control excessive deformation and cracking. According to the California amendment, deck slabs shall be designed for Class 2 exposure,

$$\gamma_e = 0.75 \qquad \qquad \qquad \text{(CA 9.5.2)}$$

10.3.2.2 Strength Limit State

Concrete decks must be designed for Strength I limit state. Because concrete deck slabs are usually designed as tension-controlled reinforced concrete components, the resistance factor is $\phi = 0.9$ (AASHTO 5.5.4.2). Strength II limit state typically is not checked for deck designs. The permit vehicle axle load does not typically control deck design (CA C3.6.1.3.3).

10.3.2.3 Extreme Event Limit State

Most bridge decks include an overhang with a concrete barrier attached. Therefore, the deck overhang has to be designed to meet the requirements for Extreme Event II. The LRFD Specifications require bridge deck overhangs to be designed for the following cases (AASHTO Appendix A13.4):

Design Case 1: The transverse and longitudinal forces specified in AASHTO Appendix A13.2 - Extreme Event Load Combination II limit state.

Design Case 2: The vertical forces specified in AASHTO Appendix A13.2 - Extreme Event Load Combination II limit state.

Design Case 3: The loads, specified in AASHTO Article 3.6.1, that occupy the overhang- Load Combination Strength I limit state.

10.3.2.4 Fatigue Limit State

Concrete decks supported by multi-girder systems are not required to be investigated for fatigue (AASHTO 9.5.3).

10.3.3 Methods of Analysis

10.3.3.1 Approximate Method of Analysis

Caltrans traditionally designs concrete bridge decks as transverse strips as a flexure member. This method is called the Approximate Method of Analysis (AASHTO 4.6.2.1). The concrete deck is assumed to be transverse slab strips, which is supported by the girders. To simplify the design, it is assumed that the girders are rigid supports. The AASHTO specifications allow the maximum positive moment and the maximum negative moment to apply for all positive moment regions and all negative moment regions in the slab, respectively.

The width of an equivalent strip (interior strip) is dependent on the type of deck used, the primary direction of the strip relative to the direction of traffic, and the sign of the moment. AASHTO Table 4.6.2.1.3-1 only applies for interior strips and not for overhangs.

10.3.3.2 Refined Methods of Analysis

The Refined Methods of Analysis (AASHTO 4.6.3) as listed in AASHTO 4.4 are acceptable methods for analyzing concrete bridge decks. But these various methods are not typically used to analyze a standard bridge deck. A refined analysis method would be better suited for a more complex deck slab structure, which would require a more detailed analysis.

10.3.3.3 Empirical Method of Analysis

Empirical Design (AASHTO 9.7.1) is a method of deck slab design based on the concept of internal arching action within concrete slabs. But, until further durability testing of this design method is completed, the empirical design method is not permitted for concrete bridge deck design in California (CA 9.7.2.2).

AASHTO Table 4.6.2.1.3-1 Equivalent Strips.

Type of Deck	Direction of Primary Strip Relative to Traffic	Width of Primary Strip (in.)
Concrete: <ul style="list-style-type: none"> • Cast-in-place • Cast-in-place with stay-in-place concrete formwork • Precast, post-tensioned 	Overhang Either Parallel or Perpendicular	$45.0 + 10.0X$ $+M: 26.0 + 6.6S$ $-M: 48.0 + 3.0S$
Steel: <ul style="list-style-type: none"> • Open grid • Filled or partially filled grid • Unfilled, composite grids 	Main Bars Main Bars Main Bars	$1.25 P + 4.0 S_b$ Article 4.6.2.1.8 applies Article 4.6.2.1.8 applies
Wood: <ul style="list-style-type: none"> • Prefabricated glulam <ul style="list-style-type: none"> ○ Non interconnected ○ Interconnected • Stress-laminated • Spike-laminated <ul style="list-style-type: none"> ○ Continuous decks or Interconnected panels ○ Non interconnected panels 	Parallel Perpendicular Parallel Perpendicular Parallel Perpendicular Parallel Perpendicular Parallel Perpendicular	$2.0 h + 30.0$ $2.0 h + 40.0$ $90.0 + 0.84L$ $4.0 h + 30.0$ $0.8 S + 108.0$ $10.0 S + 24.0$ $2.0 h + 30.0$ $4.0 h + 40.0$ $2.0 h + 30.0$ $2.0 h + 40.0$
<p> S = spacing of supporting components (ft.) h = depth of deck (in.) l = span length of deck (ft.) P = axle load (kip) S_b = spacing of gird bars (in.) $+M$ = positive moment $-M$ = negative moment X = distance from load to point of support (ft.) </p>		

10.4 DESIGN CONSIDERATIONS

Concrete decks are primarily designed for flexure in the transverse direction; therefore, the spacing of adjacent girders is important. AASHTO Table A4-1 provides a listing of design moments for “S” (girder spacing) values between 4 ft. and 15 ft. When “S” exceeds 15 ft., special design is required.

The designer needs to consider required deck thickness. According to CA 9.7.1.1 (Caltrans 2008a), the minimum deck thickness is to “conform to the deck design standards developed by Caltrans”. For the typical deck slab, MTD 10-20 (Caltrans 2008b) provides the minimum deck slab thicknesses and reinforcement schedule for various girder types. The typical deck slab thickness varies from 7 in. to 10 3/8 in. depending on the girder type and spacing.

The minimum concrete cover is determined in accordance with CA 5.12.3. Extreme environments can have a negative effect on the service life of a concrete deck slab. Corrosion of the reinforcing steel should be a major concern when designing a bridge deck in an extreme environment. There are various ways for the designer to protect against corrosion of the bridge deck. See MTD 10-5 (Caltrans 2002) for more information on protecting against corrosion.

For design purposes, the minimum compressive concrete strength $f'_c = 3.6$ ksi shall be used for reinforced concrete (CA 5.4.2.1).

10.5 DETAILING CONSIDERATIONS

10.5.1 Reinforcement Details

Typical reinforced concrete decks are detailed as part of the superstructure typical section. The designer should use MTD 10-20 (Caltrans 2008b) for required minimum reinforcement and Standard Plan B0-5 for transverse reinforcement spacing diagrams. It is important to check main longitudinal reinforcement spacing and cover to ensure reinforcing steel can fit within slab thickness.

For variable width girders it is important for the designer to specify reinforcement spacing and type that differs from the standard superstructure bay. See BDD 8-34 (Caltrans 1994) for more information on acceptable reinforcement detailing in variable bays. Limits of epoxy-coated reinforcement shall also be specified.

10.5.2 Skewed Decks

Designers must give special consideration to detailing reinforcement for skewed bridge decks. For skews less than 20° the transverse deck reinforcement is parallel to the centerline of the abutment. For skew angles greater than 20° the transverse deck reinforcement is normal to the center line of the girder. Special corner details are usually required to clarify the deck reinforcement and diaphragm connections. BDD 8-36 (Caltrans 1990) provides examples of the correct way to detail skewed deck corners as shown in Figure 10.5-1.

SKEWED DECK CORNER REINFORCEMENT

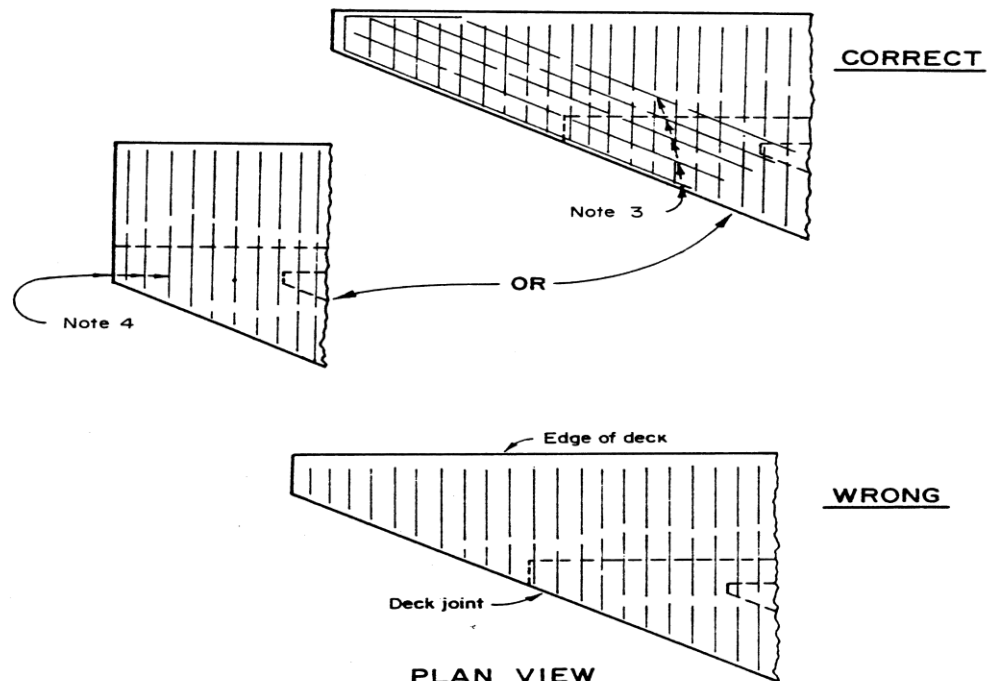

NOTES TO DESIGNER

1. Special consideration should be given to detailing the deck reinforcement in skewed corners of bridge decks.
2. Consider squaring off the deck at the end of the girder or placing reinforcing parallel to the abutment.
3. The designer should determine the amount and location of the reinforcement.
4. All reinforcement should be adequately anchored.

Figure 10.5-1 BDD 8-36 Skewed Deck Corner Reinforcement.

10.5.3 Deck Drains and Access Openings

After determination of the type of deck drain and the deck drain location, it is important to ensure that the drain fits the location specified. Depending on the type of deck drain used it may be necessary to provide additional reinforcement to secure the drain assembly in place.

Deck openings are discouraged. Soffit openings are the preferred method to provide access into the bridge bays. If deck openings are used then Standard Plan B7-11 Utility Details provide additional reinforcement for openings.

10.6 DESIGN EXAMPLE – REINFORCED CONCRETE BRIDGE DECK

10.6.1 Concrete Deck Data

A typical section of a reinforced concrete box girder bridge is shown in Figure 10.6-1.

Max. Girder Spacing: $S = 12$ ft.

Number of Girders: $N = 5$

Concrete compressive strength: $f'_c = 3.6$ ksi (CA 5.4.2.1)

Reinforcement strength: $f_y = 60$ ksi

Type 732 Concrete Barrier weight: $w_{732} = 0.410$ klf

Future wearing surface, $w_{fws} = 0.140$ kcf (AASHTO Table 3.5.1-1)

(Assume 3" thick asphalt section were, $w_{fws} = 0.140$ kcf \times 0.25ft = 0.035 ksf)

Reinforced Concrete unit weight, $w_{rc} = 0.150$ kcf (AASHTO C3.5.1)

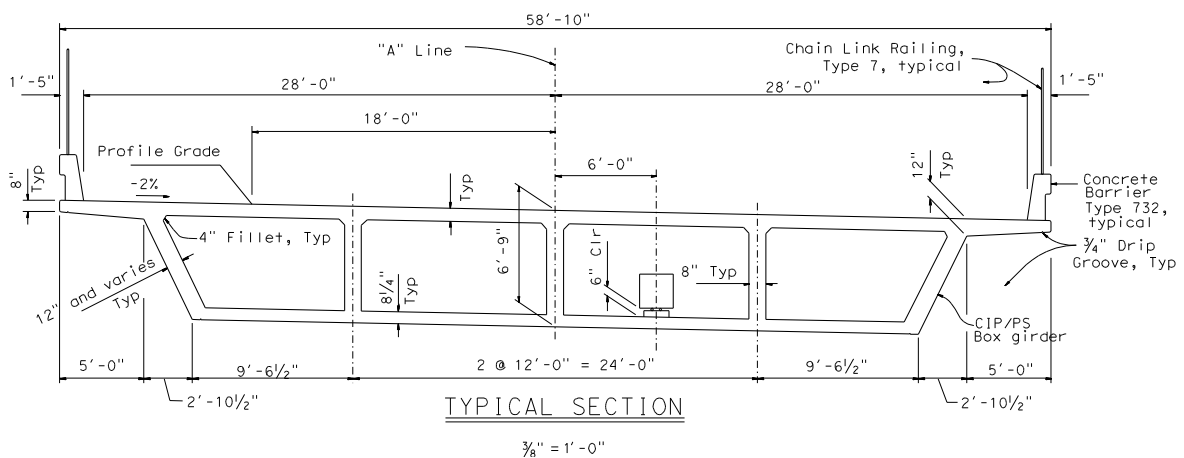

Figure 10.6-1 Reinforced Concrete Box Girder Bridge Typical Section.

10.6.2 Design Requirements

Design the concrete bridge deck supported by the girders using the Approximate Method of Analysis (AASHTO 4.6.2) in accordance with the AASHTO LRFD (AASHTO 2007) with California Amendments (Caltrans 2008a).

10.6.3 Determine Minimum Deck Thickness and Cover

According to CA 9.7.1.1 (Caltrans 2008a), the minimum deck thickness must conform to the deck design standards specified by MTD 10-20 (Caltrans 2008b). The minimum deck thickness varies depending on the girder type and the centerline to centerline spacing. Therefore, for a reinforced concrete box girder bridge,

$S = 12.00$ ft assumes a minimum thickness $t = 9 \frac{1}{8}$ in.

The minimum concrete cover is determined according to CA Table 5.12.3-1. For the top surface of the bridge deck in a non-corrosive atmosphere the minimum cover is specified as:

Deck Top Cover: $C_{top} = 2.0$ in.

The minimum cover specified for the bottom surface of the deck slab is:

Deck Bottom Cover: $C_{bottom} = 1.0$ in.

10.6.4 Compute Unfactored Dead Load Moments

The dead load moments for the deck slab, barrier and future wearing surface are computed for a one-foot wide section of the bridge deck using any approved structural analysis method. This can include the continuous beam equations, moment distribution, or an acceptable computer analysis program. Table 10.6-1 lists the tabulated unfactored dead load moments for each bay given in tenth points using a finite element analysis.

Table 10.6-1 Unfactored Dead Load Moments.

Distance	Slab Dead Load-DC1 (K-FT/FT)				Barrier Load-DC2 (K-FT/FT)				Future Wearing Surface Dead Load-DW (K-FT/FT)			
	Bay 1	Bay 2	Bay 3	Bay 4	Bay 1	Bay 2	Bay 3	Bay 4	Bay 1	Bay 2	Bay 3	Bay 4
0	-1.62	-1.30	-1.40	-1.30	-1.81	0.51	-0.25	0.51	-0.26	-0.46	-0.40	-0.46
0.1	-0.84	-0.57	-0.65	-0.60	-1.56	0.43	-0.18	0.28	-0.05	-0.23	-0.18	-0.22
0.2	-0.24	-0.01	-0.07	-0.05	-1.35	0.36	-0.10	0.05	0.11	-0.05	-0.01	-0.02
0.3	0.21	0.40	0.35	0.33	-1.11	0.28	-0.02	-0.18	0.21	0.08	0.11	0.13
0.4	0.05	0.63	0.61	0.55	-0.88	0.21	0.05	-0.42	0.27	0.16	0.18	0.22
0.5	0.60	0.70	0.70	0.60	-0.65	0.13	0.13	-0.65	0.27	0.20	0.20	0.27
0.6	0.55	0.61	0.63	0.48	-0.42	0.05	0.21	-0.88	0.22	0.18	0.16	0.27
0.7	0.33	0.35	0.40	0.21	-0.18	-0.02	0.28	-1.11	0.13	0.11	0.08	0.21
0.8	-0.05	-0.07	-0.01	-0.24	0.05	-0.10	0.36	-1.35	-0.02	-0.01	-0.05	0.11
0.9	-0.60	-0.65	-0.57	-0.84	0.28	-0.18	0.43	-1.56	-0.22	-0.18	-0.23	-0.05
1	-1.30	-1.40	-1.30	-1.62	0.51	-0.25	0.51	-1.81	-0.46	-0.40	-0.46	-0.26

10.6.5 Compute Unfactored Live Load Moments

The unfactored live load moments are determined from AASHTO Appendix A4, Table A4-1. This table can be used for decks supported on at least three or more girders, in which the minimum superstructure width, between centerline to centerline of exterior girders, cannot be less than 14'-0". The moments are calculated using the equivalent strip method (AASHTO 4.6.2.1.3) for concrete slabs supported on parallel girders. The values given in the table include multiple presence factors and the dynamic load allowance. To be conservative use the largest span length between girders to find the maximum live load force effect.

AASHTO Table A4-1 Maximum Live Load Moments Per Unit Width, kip-ft./ft.

S	Positive Moment	NEGATIVE MOMENT						
		Distance from CL of Girder to Design Section for Negative Moment						
		0.0 in.	3 in.	6 in.	9 in.	12 in.	18 in.	24 in.
11' -9"	7.88	10.01	9.12	8.24	7.36	6.47	5.40	5.05
12' -0"	8.01	10.28	9.40	8.51	7.63	6.74	5.56	5.21
12' -3"	8.15	10.55	9.67	8.78	7.90	7.02	5.75	5.38
12' -6"	8.28	10.81	9.93	9.04	8.16	7.28	5.97	5.54
12' -9"	8.41	11.06	10.18	9.30	8.42	7.54	6.18	5.70

From the table, use a maximum spacing of 12'-0" for the girder spacing. The positive live load moment is 8.01 kip-ft./ft. The maximum negative moment is given in relationship to the distance from the centerline of the girder to the design section. In the design example, the girder width is 8 inches. The maximum negative moment design section is 4 in., which is the distance from the girder centerline to the edge of the girder (AASHTO 4.6.2.1.6). The closest value to 4 in. in the Table is 3 in. Therefore, the corresponding maximum negative moment is 9.40 kip-ft./ft.

10.6.6 Calculate the Factored Design Moments

Concrete decks are designed for strength, service and extreme limit states according to AASHTO 9.5. Fatigue and fracture limit states need not be investigated for concrete decks supported by multiple girders (AASHTO 5.5.3 Fatigue Limit State). Therefore,

Strength I Load Combination

$$M_u = \eta[\gamma_{DC}M_{DC} + \gamma_{DW}M_{DW} + (m)(1 + IM)(\gamma_{LL})(M_{LL})]$$

- $\eta = 1.0$ (Note: Per CA 1.3.4, $\eta = 1.0$ until its application is better defined.)
- For the slab and barrier (DC):
 $\gamma_{DC} = 1.25$ Maximum factor
- For future wearing surface (DW):
 $\gamma_{DW} = 1.50$ Maximum factor
- Multiple Presence Factor, $m = 1.20$ for one lane of vehicular live load. This value is included in the tabulated moments provided in Table A4-1.
- Dynamic Load Allowance, IM , is also included in Table A4-1 tabulated moments.
- $\gamma_{LL} = 1.75$, for Strength I Load Combinations.

10.6.6.1 Maximum Positive Factored Moments

Based on Table 10.6-1, the maximum unfactored positive moment due to the slab, barrier, and future wearing surface is located in Bay 2 or 3 at a distance of 0.5S. The maximum positive moment equals 8.01 kip-ft./ft, as shown in Section 10.6.5. Therefore, the maximum positive factored moment is

$$M_u = 1.0[(1.25)(0.70+0.13)+(1.5)(0.20)+(1.75)(8.01)] = 15.36 \text{ kip-ft./ft.}$$

10.6.6.2 Maximum Negative Factored Moments

The maximum unfactored negative moment due to the slab, barrier and future wearing surface is located in Bay 1 at a distance of 0 (center of exterior girder). The negative moment can be reduced at the face of the girder. The negative moment can be interpolated between 0.0S and 0.1S. Based on the reduced negative moments at the interior face of the girder, the maximum negative factored moment is

$$M_u = 1.0[(1.25)(1.29+1.71)+(1.5)(0.17)+(1.75)(9.40)] = 20.46 \text{ kip-ft./ft.}$$

10.6.7 Positive Flexure Design

To design for the maximum positive moment, first, assume an initial bar size. From this initial bar size, the required area of steel can be calculated. Then the reinforcement spacing can be determined. For this example the assumed initial reinforcing steel size is #5.

For a #5-bar,
 Bar area = 0.31 in²
 Bar diameter = 0.625 in.

Next, determine the effective depth, d_e , which is equal to the total slab thickness minus the bottom cover, C_{bottom} , and minus half the bar diameter. Figure 10.6-2 shows the relationship between the effective depth and the slab thickness.

$$d_e = t - C_{bottom} - \frac{(bar_diameter)}{2} = 9.125 - 1.0 - \frac{(0.625)}{2} = 7.813 \text{ in.}$$

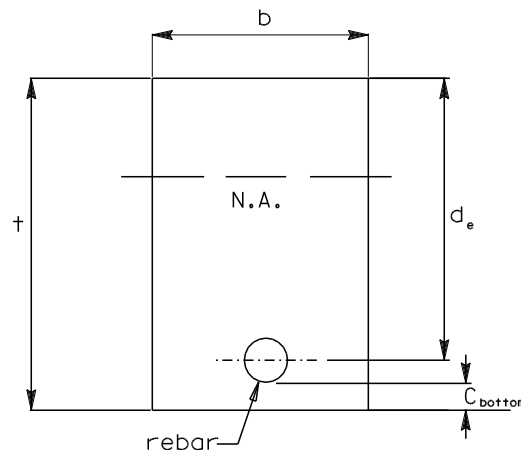

Figure 10.6-2 Simple Rectangular Concrete Section with Tension Reinforcement.

For a rectangular section, assume $a \leq \frac{t}{2}$, where a is the depth of the equivalent stress block, and t is the deck thickness. Solve for the required amount of reinforcement, as follows:

$$A_s = \frac{z}{2} \left[1 - \sqrt{1 - \frac{4M_u}{\phi f_y d_e z}} \right]$$

Where,

$$z = \frac{1.7 f'_c b d_e}{f_y}$$

$$\phi = 0.9 \text{ (Assume tension control)} \quad \text{(AASHTO 5.5.4.2.1)}$$

$$b = 12 \text{ in.}$$

Therefore,

$$z = 9.56 \text{ in.}^2$$

$$A_s = 0.459 \text{ in.}^2$$

$$\text{Check } a \leq \frac{t}{2},$$

$$a = \frac{A_s f_y}{0.85 f'_c b} = 0.75 \text{ in} < 4.56 \text{ in.}$$

Next, determine the required bar spacing,

$$\text{bar_spacing} = \frac{12 \times \text{bar_area}}{A_s} = \frac{12 \times 0.31}{0.459} = 8.10 \text{ in. use, 8 in. spacing for \#5 bar.}$$

To verify that tension controls the section design and that the proper resistance factor is used to check the strain in the extreme tension reinforcing steel (AASHTO CA 5.7.2.1). The strain, stress and force diagrams for a rectangular concrete section are shown in Figure 10.6-3.

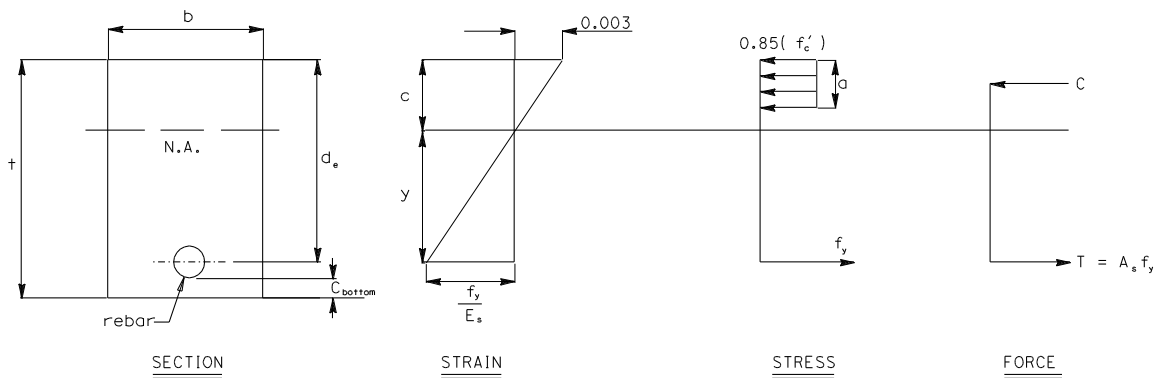

Figure 10.6-3 Development of Bending Strain, Stress, and Force Actions in a Section.

Calculate the tension force and the area of concrete.

$$\#5 @ 8'' \Rightarrow A_s = \frac{12(0.31)}{8} = 0.465 \text{ in.}^2$$

$$T = A_s f_y = 0.465(60) = 27.9 \text{ kips}$$

$$T = A_c (0.85) f'_c \Rightarrow A_c = \frac{T}{0.85 f'_c} = \frac{27.9}{0.85(3.6)} = 9.12 \text{ in.}^2$$

Determine concrete compression block depth, a

$$a = \frac{A_c}{b} = \frac{9.12}{12} = 0.76 \text{ in.}$$

Determine c from the equation $a = \beta_1 c$

$$c = \frac{a}{\beta_1} = \frac{0.76}{0.85} = 0.89$$

Check if steel yields,

$$\epsilon_s = \frac{y}{c} (0.003) = \frac{(7.813 - 0.89)}{0.89} (0.003) = 0.023 \geq 0.004$$

The steel yields and the section is tension controlled, therefore, the proper resistance factor was used.

Finally, check maximum spacing for primary reinforcement (AASHTO 5.10.3.2). The spacing of the slab reinforcement shall not exceed 1.5 times the thickness of the slab or 18.0 in. In this case the maximum spacing equals 8.0 in., which is less than either case.

10.6.8 Negative Flexure Design

Designing for the maximum negative flexure reinforcement is similar to designing for the maximum positive moment reinforcement. These bars are the primary reinforcing steel over the girders as shown in Figure 10.6-4.

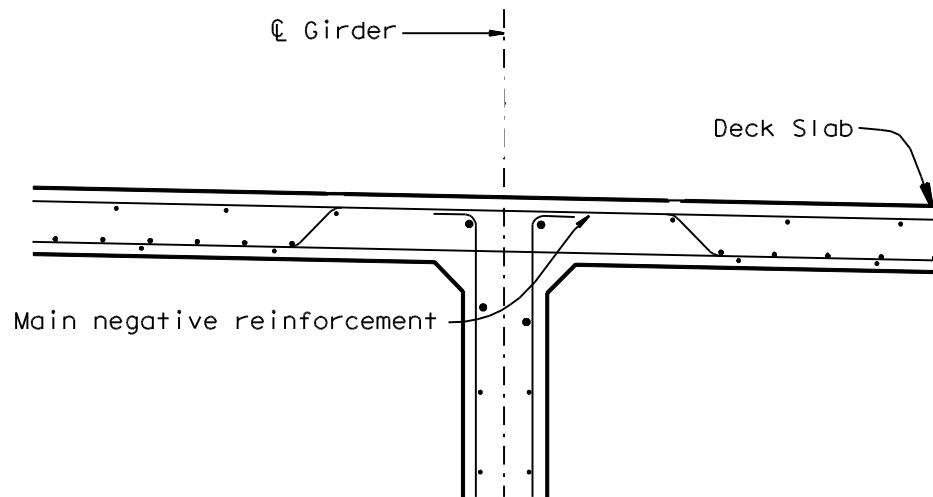

Figure 10.6-4 Negative Reinforcement over a Typical Girder.

Assuming #6 bar size.
 Bar area = 0.44 in.²
 Bar diameter = 0.750 in.

The effective depth, d_e , for the negative moment is equal to the total slab thickness minus the top cover, C_{top} , and half the bar diameter.

$$d_e = t - C_{top} - \frac{(bar_diameter)}{2} = 9.125 - 2.0 - \frac{(0.750)}{2} = 6.75 \text{ in.}$$

Based on the maximum negative moment

$$z = 8.262 \text{ in.}^2$$

$$A_s = 0.740 \text{ in.}^2$$

Check $a \leq \frac{t}{2}$,

$$a = \frac{A_s f_y}{0.85 f'_c b} = 1.209 \text{ in.} < 4.56 \text{ in.}$$

Required bar spacing is

$$bar_spacing = \frac{12 \times bar_area}{A_s} = \frac{12 \times 0.44}{0.740} = 7.14 \text{ in.}^2, \text{ use } 7.0 \text{ in. spacing.}$$

Verify that tension controls the section design and that the proper resistance factor is used to check the strain in the extreme tension reinforcing steel (AASHTO CA 5.7.2.1). Finally, check maximum spacing for primary reinforcement per AASHTO 5.10.3.2.

10.6.9 Check for Crack Control under Service Limit State

Concrete cracking is controlled by the spacing of flexure reinforcement. To improve crack control in the concrete deck, the reinforcement has to be well distributed over the area of maximum tension. Therefore, AASHTO requires steel reinforcement spacing to satisfy the following:

$$s \leq \frac{700\gamma_e}{\beta_s f_{ss}} - 2d_c \quad (\text{AASHTO 5.7.3.4-1})$$

In which,

$$\beta_s = 1 + \frac{d_c}{0.7(h - d_c)}$$

Where,

$$\gamma_e = 0.75 \text{ for Class 2 exposure conditions} \quad (\text{CA 5.7.3.4 \& 9.5.2})$$

$$d_c = 2 \text{ 1/2 in. for bridge decks} \quad (\text{CA 5.7.3.4})$$

$$f_{ss} = \text{tensile stress in steel reinforcement at service limit state (ksi)}$$

$$h = \text{overall thickness of deck (in.)}$$

10.6.9.1 Determine Maximum Loading under Service Limit State

Service I Load Combination

$$M_s = 1.0 [1.0M_{DC} + 1.0M_{DW} + (m)(1 + IM)1.0(M_{LL})]$$

Positive moment due to service loading:

$$M_{\text{positive}} = 1.0 [(1.0)(0.70 + 0.13) + (1.0)(0.20) + (1.0)(8.01)] = 9.04 \text{ kip-ft./ft.}$$

Negative moment due to service loading:

$$M_{\text{negative}} = 1.0 [(1.0)(1.29 + 1.71) + (1.0)(.17) + (1.0)(9.40)] = 12.57 \text{ kip-ft./ft.}$$

Negative Service Loading Controls.

10.6.9.2 Determine Maximum Required Spacing for Crack Control

Determine the neutral axis location, y , based on the transformed section properties.

$$\frac{b}{2}y^2 + nA_s y - nA_s d_e = 0$$

Let

$$A = \frac{b}{2}$$

$$B = nA_s$$

$$C = -nA_s d_e$$

Therefore,

$$y = \frac{-B + \sqrt{B^2 - 4AC}}{2A}$$

$$A_s = \text{bar area} \times \frac{12}{7.0} = 0.754 \text{ in.}^2$$

$$n = 8$$

$$A = \frac{b}{2} = \frac{12}{2} = 6$$

$$B = nA_s = 8 \times 0.754 = 6.03$$

$$C = -nA_s d_e = -(8 \times 0.754 \times 6.75) = -40.72$$

$$y = \frac{-B + \sqrt{B^2 - 4AC}}{2A} = 2.151 \text{ in.}$$

Calculate the crack moment of inertia, I_{cr} , for the transformed section.

$$I_{cr} = \frac{by^3}{3} + nA_s(d_e - y)^2 = 167.44 \text{ in.}^4$$

Next, calculate the tensile stress, f_{ss} , in the steel reinforcement at service limit state.

$$f_{ss} = \frac{nM_s(d_e - y)}{I_{cr}} = 33.15 \text{ ksi}$$

Finally, determine β_s , and then input that value into the formula to calculate the maximum spacing, s , of the reinforcement that would satisfy the LRFD crack control requirement.

$$\beta_s = 1 + \frac{d_c}{0.7(h - d_c)} = 1 + \frac{2.5}{0.7 \times (9.125 - 2.5)} = 1.539$$

$$s = \frac{700\gamma_e}{\beta_s f_{ss}} - 2d_c = \frac{700 \times (0.75)}{(1.539) \times (33.15)} - (2) \times (2.5) = 5.29 \text{ in.}$$

Figure 10.6-5 shows Caltrans' Standard Plan for transverse deck reinforcement spacing. To convert the required spacing to Caltrans' Standard Plan Bridge Details 5-11 or 5-10, you must multiply the spacing by 2. This is due to the fact that the transverse deck reinforcement spacing diagrams add an extra top bar for the given spacing. Therefore, if the required calculated spacing is 5.29 in., then the spacing shown on the typical section would be 10.58 in. In the design example case, we would specify #6 @ $S = 10 \frac{1}{2}$ in.

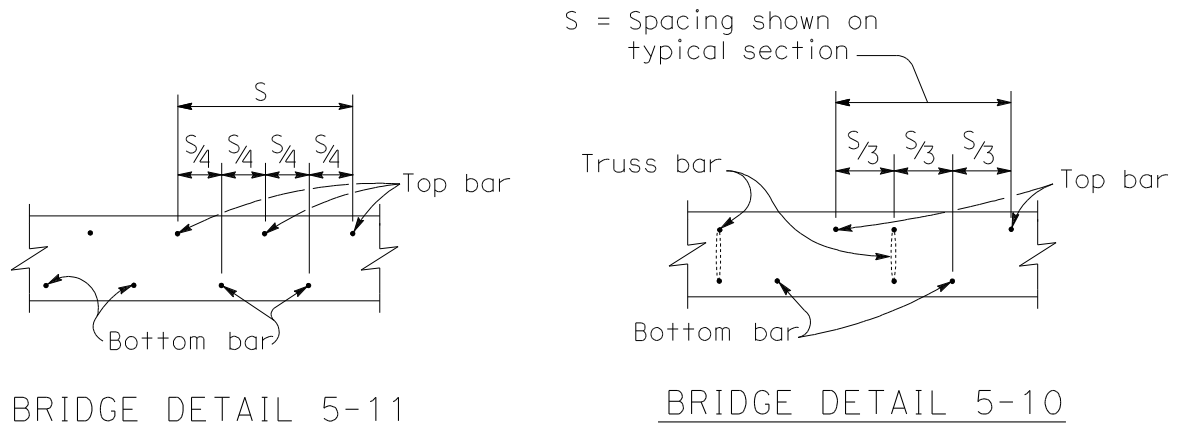

TRANSVERSE DECK REINFORCEMENT SPACING DIAGRAMS

Figure 10.6-5 Standard Plan Spacing Details.

10.6.10 Minimum Reinforcement

Minimum reinforcement is needed in the slab to distribute the load across the slab, for shrinkage, and temperature change. For the typical slab design, AASHTO requires distribution reinforcement for the top of the slab and the bottom of the slab.

10.6.10.1 Top of Slab Shrinkage and Temperature Reinforcement

The top slab reinforcement is for shrinkage and temperature changes near the surface of the exposed concrete slab. The area of reinforcement has to meet the following requirements:

$$A_s \geq \frac{1.3bh}{2(b+h)f_y} \quad (5.10.8-1)$$

$$0.11 \leq A_s \leq 0.60 \quad (5.10.8-2)$$

Where:

- A_s = area of reinforcement in each direction and each face (in.²/ft.)
- b = least width of component section (in.)
- h = least thickness of component section (in.)
- f_y = specified yield strength of reinforcing bars ≤ 75 ksi

For the design example slab:

$$A_s = \frac{1.3bh}{2(b+h)f_y} = \frac{1.3(12)(9.125)}{2(12+9.125)(60)} = 0.056 \text{ in.}^2/\text{ft.}$$

$$A_s = 0.056 \leq 0.11, \text{ therefore, } A_s = 0.11 \text{ as a minimum.}$$

Use #4 bars in top slab.

$$\text{Bar area} = 0.2 \text{ in.}^2$$

$$\text{Bar spacing} = \frac{12(0.2)}{0.11} = 21.8 \text{ in. use maximum } 18.0 \text{ in.}$$

10.6.10.2 Bottom of Slab Distribution Reinforcement

The reinforcement in the bottom of the slab is a percentage of the primary deck reinforcement. The primary deck reinforcement is perpendicular to the direction of traffic, therefore, the requirement is $220/\sqrt{S} \leq 67$ percent, where S is the effective span length (ft.) as specified in Article 9.7.2.3. For the design example, the effective span length is the clear distance from face of girder to face of girder, which is 11 ft.

$$220/\sqrt{S} = 220/\sqrt{11} = 66\% < 67\%$$

$$A_{\text{required}} = 0.66 \times 1.01 = 0.67 \text{ in.}^2/\text{ft.}$$

To facilitate better lateral load distribution, Caltrans' Reinforced Concrete Technical Committee recommends that the bottom deck reinforcement be placed within the center half of the deck span. Therefore,

$$\frac{1}{2} S = \frac{11}{2} = 5.5 \text{ ft.}$$

$$5.5 \times 0.67 \frac{\text{in.}^2}{\text{ft.}} = 3.685 \text{ in.}^2 \div 0.31 \text{ in.}^2 = 11.89 \approx 12 \text{ bars}$$

Twelve bars are distributed within 1/2 the effective span length. Compared this with the standard Deck Slab Reinforcement Details "G" bars and "D" bars per MTD Table 10-20.1(a):

The required "G" bars for 12'-0" girder spacing are 5 - #4 bars

The required "D" bars for 12'-0" girder spacing are 13 - #5 bars

Figure 10.6-6 Shows the detailed deck reinforcement for the design example.

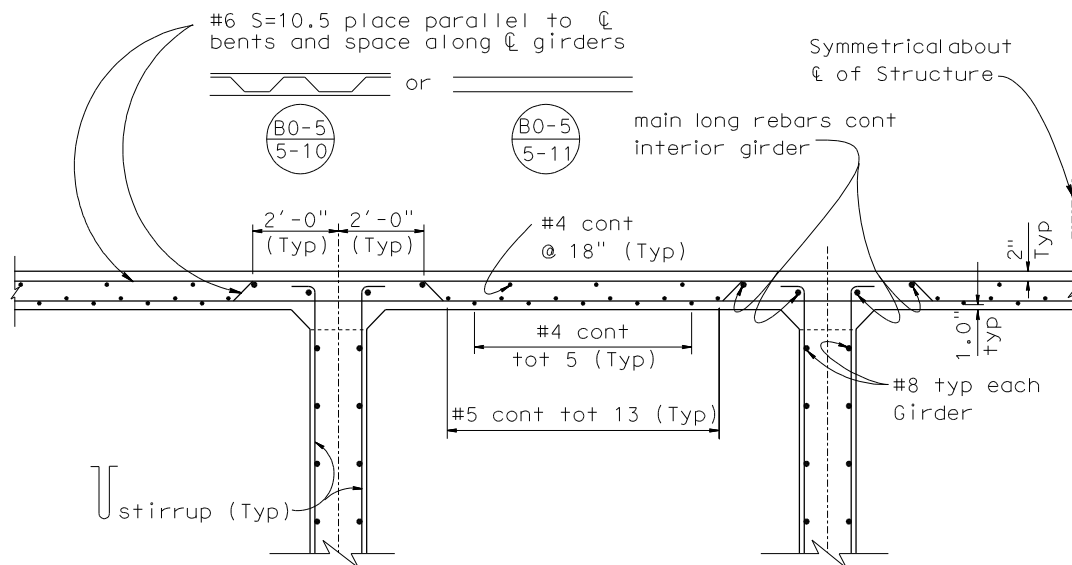

Figure 10.6-6 Bridge Deck Reinforcement Detail.

NOTATION

- A_s = area of tension reinforcement (in.²)
- a = depth of equivalent rectangular stress block (in.)
- b = width of the compression face of the member (in.)
- C_{bottom} = required concrete cover over bottom deck reinforcing steel (in.)
- C_{top} = required concrete cover over top deck reinforcing steel (in.)
- d_c = thickness of concrete cover measured from extreme tension fiber to center of bar (in.)
- d_e = effective depth from extreme compression fiber to the centroid of the tensile force in the tension reinforcement (in.)
- f'_c = specified compressive strength of concrete for use in design (ksi)
- f_y = specified minimum yield strength of reinforcing bars (ksi)
- f_{ss} = tensile stress in mild steel reinforcement at the service limit state (ksi)
- h = overall thickness of deck (in.)
- I_{cr} = moment of inertia of the cracked section, transformed to concrete (in.⁴)
- IM = dynamic load allowance
- M_{DC} = moment due to dead load (k-ft.)
- M_{DW} = moment due to dead load wearing surface (k-ft.)
- M_{LL} = moment due to live load (k-ft.)
- M_s = moment due to service loads (k-ft.)
- M_u = factored moment at the section (k-ft.)
- m = multiple presence factor
- N = number of girders
- n = modular ratio = E_s/E_c
- S = center to center spacing of girder (ft.); effective span length (ft.)
- t = thickness of slab (in.)
- w = uniform load (k/ft.)
- y = distance from neutral axis location to the extreme tension fiber (in.)
- γ_e = crack control exposure condition factor
- γ_{DC} = load factor for permanent dead load
- γ_{DW} = load factor for component dead load



- γ_{LL} = load factor for live load
- η = load modifier
- ϕ = resistance factor

REFERENCES

1. AASHTO, (2007). *LRFD Bridge Design Specifications*, American Association of State Highway and Transportation Officials, 4th Edition, Washington, D.C.
2. Caltrans, (2008a). *California Amendments to AASHTO LRFD Bridge Design Specifications*, California Department of Transportation, Sacramento, CA.
3. Caltrans, (2008b). *Bridge Memo to Designers (MTD) 10-20: Deck and Soffit Slabs*, California Department of Transportation, Sacramento, CA.
4. Caltrans, (2002). *Bridge Memo to Designers (MTD) 10-5: Protection of Reinforcement Against Corrosion Due to Chlorides, Acids and Sulfates*, California Department of Transportation, Sacramento, CA.
5. Caltrans, (1994). *Bridge Design Details Manual*, California Department of Transportation, Sacramento, CA.
6. Caltrans, (1995). *Bridge Memo to Designers*, California Department of Transportation, Sacramento, CA.
7. Caltrans, (2006). *Standard Plans*, California Department of Transportation, Sacramento, CA.
8. Chen, W. F., and Duan, L. (1999). *Bridge Engineering Handbook*, CRC Press, Boca Raton, FL.
9. Csagoly, P. and Lybas, J. (1989). "Advance Design Method for Concrete Bridge Deck Slabs," *Concrete International, ACI*. Vol.11.
10. Fu, G. K., et al, (2000). "Effect of Truck Weight on Bridge Network Costs", *NCHRP: Report 495*, Transportation Research Board, Washington, D.C.



This page is intentionally left blank.