

SANDWICH PANEL FABRICATION TECHNOLOGY

Hexcel Composites honeycomb sandwich panels are light, stiff and durable. They are easy to fabricate into finished panels and even complex components; simple workshop techniques and inexpensive tools and equipment are often all that is required.

This guide sets out to remove any reservations about fabricating components with sandwich panels, by demonstrating typical methods and procedures.

Hexcel Composites was at the forefront of the development of honeycomb sandwich panels - over 25 years ago. The trademarks Hexlite® and Fibrelam® are now known worldwide throughout many industries.

January 1997
Publication No. LTU 018

® Hexcel Registered Trademark
© Hexcel Composites, Duxford



SANDWICH PANEL FABRICATION TECHNOLOGY

Contents

	Page
Introduction	3
Guide to Sandwich Panel Selection	4
Typical Fabricated Construction	4
Jointing and Connection Methods	5/6/7
Edge Closure Methods	8
Panel Fixing Procedures	9
Cut and Fold Fabrication	10/11
Tool Requirements	12/13
Cutting and Drilling Techniques	14
Clamping for Bonded Joints	15
Sandwich Panel Finishing	16
Health and Safety	16

INTRODUCTION

Many benefits can be designed into a panel, but fundamentally **all honeycomb sandwich panels offer outstanding stiffness and strength for low weight**. Thin, high strength skins are separated by, and bonded to, thick lightweight honeycomb cores; the thicker the core, the higher the stiffness and strength of the panel - for minimal weight gain. This is illustrated below:

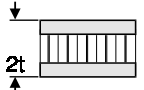
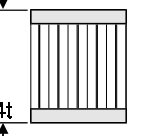
	Solid Material	Core Thickness t	Core Thickness $3t$
			
Stiffness	1.0	7.0	37.0
Flexural Strength	1.0	3.5	9.2
Weight	1.0	1.03	1.06

Honeycomb sandwich panels have been used extensively over the years, for applications where their stiffness/weight and strength/weight benefits cannot be beaten, e.g.

■ Aircraft Flooring

Almost all modern aircraft designs have honeycomb sandwich flooring - standard Fibrelam® is the world leader.

■ Aircraft Interiors

Fitted in nearly all modern aircraft - Fibrelam LS is an industry standard in this market.

■ Tooling Industry

For lightweight backing structures of checking fixtures and models.

■ Ship Interiors

Increasingly, new ships are designed for higher speed and demand lower weight panelling and furnishing materials.

■ Train Interiors

The development of high speed and light rail vehicles results in low-weight requirements for panelling and furnishings.

■ Construction Industry

For lightweight cladding and support for stone veneers, etc. - reducing overall construction time due to easier handling and lower building structure costs.

■ Many other applications ranging from the Automotive Industry, Art Restoration, to Hi-Fi speaker cabinets and machine parts.

The fabrication of honeycomb sandwich panels is simple, with many techniques borrowed from the woodworking industry.

Panels are cut into finished parts with saws, routers and drills. If necessary, edges are closed-off with edge filler, extrusions or tapes. Fixing positions can be made by bonding and the use of inserts. Individual panels can be jointed into assemblies using extrusions, or tongue-and-groove joints. The cut-and-fold technique (unique to sandwich panels) is another simple and very effective fabrication process.

This brochure gives advice on which panel to choose for a particular application, and the methods that are used to transform the panel into a finished part or assembly.

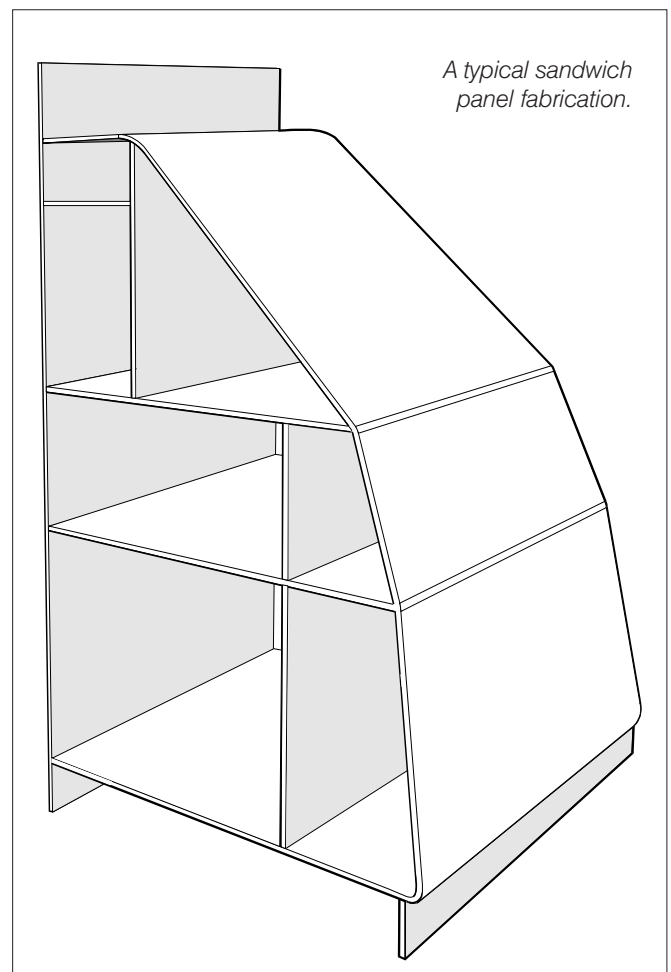

SANDWICH PANEL FABRICATION TECHNOLOGY

GUIDE TO SANDWICH PANEL SELECTION

Honeycomb sandwich panels are available in a wide range of configurations. Skin materials range from aluminium alloy, to woven or unidirectional glass or carbon fibre. The honeycomb core can be aluminium or non-metallic (Nomex*) For information on the selection of honeycombs consult Hexcel Composites' Honeycomb Selector Guide.

Standard compositions of honeycomb sandwich panels are as follows:

Panel composition	Key characteristics
Aluminium honeycomb core, aluminium skins.	Medium weight and stiffness at low cost.
Aluminium honeycomb core, woven glass fibre skins.	Lighter and less stiff than aluminium-skinned panels, at lower cost.
Non-metallic Nomex honeycomb core, unidirectional or woven glass fibre skins.	More resilient and higher cost than panels with aluminium honeycomb core. Unidirectional fibres give greater stiffness, at higher cost than woven fibres.
Non-metallic Nomex honeycomb core, unidirectional or woven carbon fibre skins.	The lightest and stiffest panels, which is reflected in their cost.

*Nomex is a registered trademark of Du Pont.

HEXLITE® INDUSTRIAL PANELS

Product Series	Skins	Core
Hexlite 100	Glass/Phenolic	Aluminium
Hexlite 200	Aluminium	Aluminium
Hexlite 300	Glass/Phenolic	Nomex
Hexlite 400	Decorative (e.g. HPL)	Aluminium
Hexlite 500	Decorative (e.g. HPL)	Nomex
Hexlite 600	Glass/Epoxy	Aluminium
Hexlite 700	Glass/Epoxy	Nomex
Hexlite 800	Miscellaneous	Miscellaneous

For further information please refer to the Hexlite® Panels Selector Guide, available from Hexcel Composites.

TYPICAL SANDWICH PANEL - JOINTING AND CONNECTION METHODS

Honeycomb sandwich panels are joined using a variety of methods some of which are illustrated:

Typical Flat Joining Methods

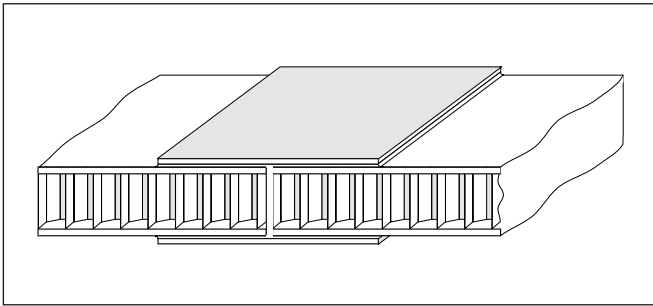

- Bonded face supported butt joint.

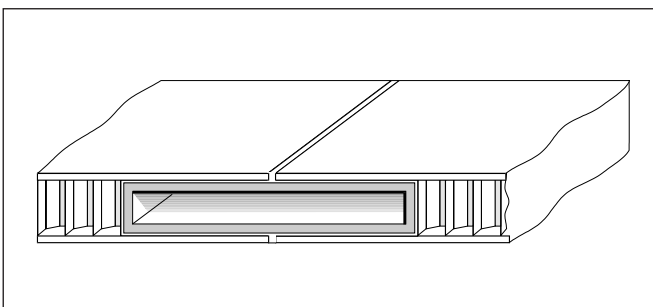

- Flush faced bonded joint, supported by a special internal extrusion (or wood block) - for volume production.

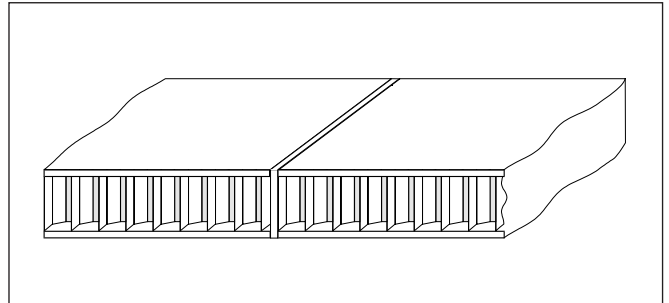

- Flush faced all bonded butt joint - for non-structural applications. Care must be taken to ensure flatness across the joint.

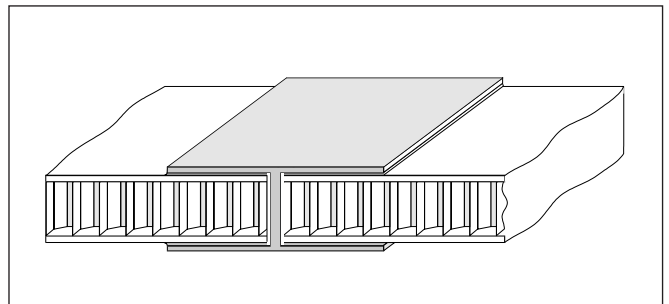

- Bonded butt joint using 'H' section extrusion for volume production.

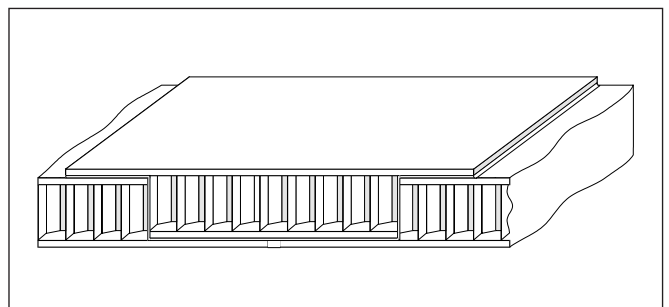

- Panel section insertion method, using same panel material.

SANDWICH PANEL FABRICATION TECHNOLOGY

Typical Corner Joints

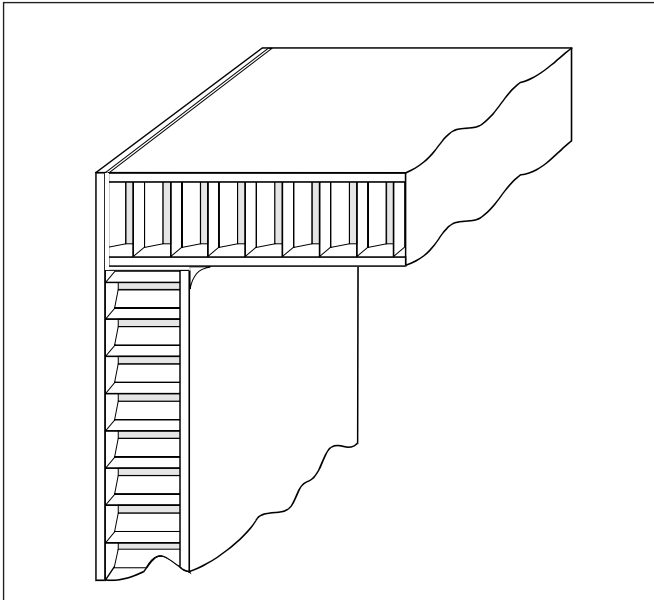

- Rebated and bonded. Low strength, and can be difficult to make square.

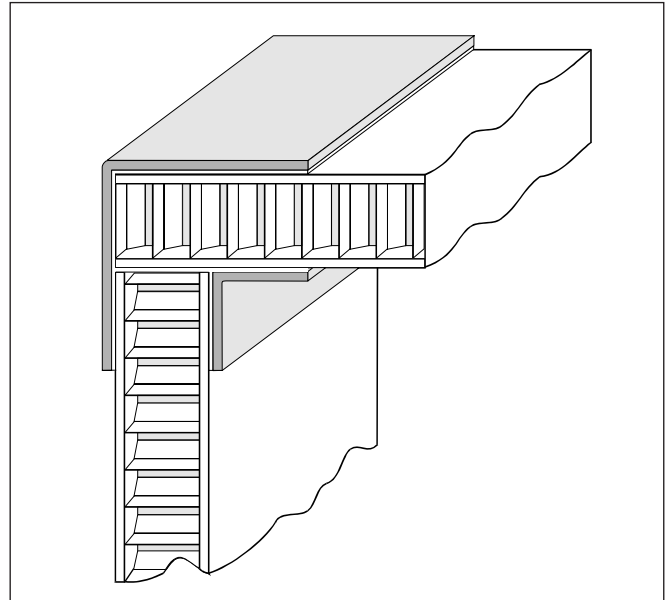

- Supported by bonded L-section extrusions.

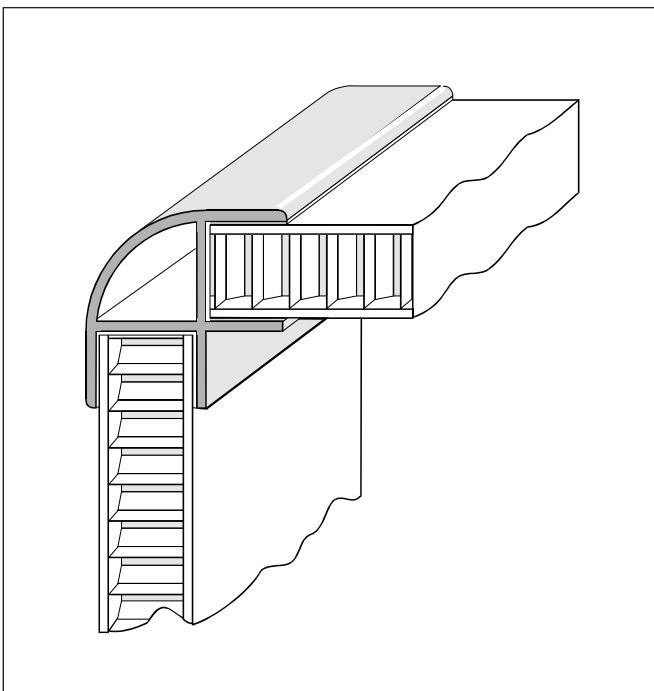

- Use of special extrusion, for volume production of rounded corners.

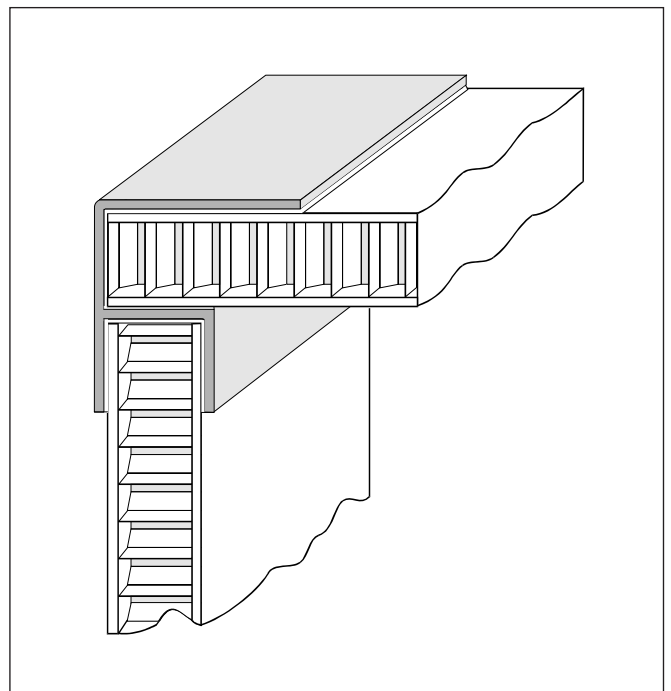

- Use of special extrusion, for volume production of square corners.

'T' Joints

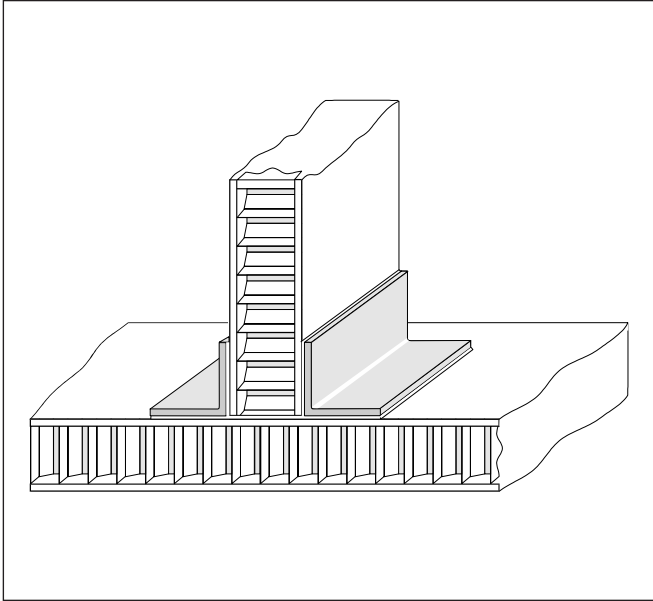

■ Joint supported by bonded L-sections.

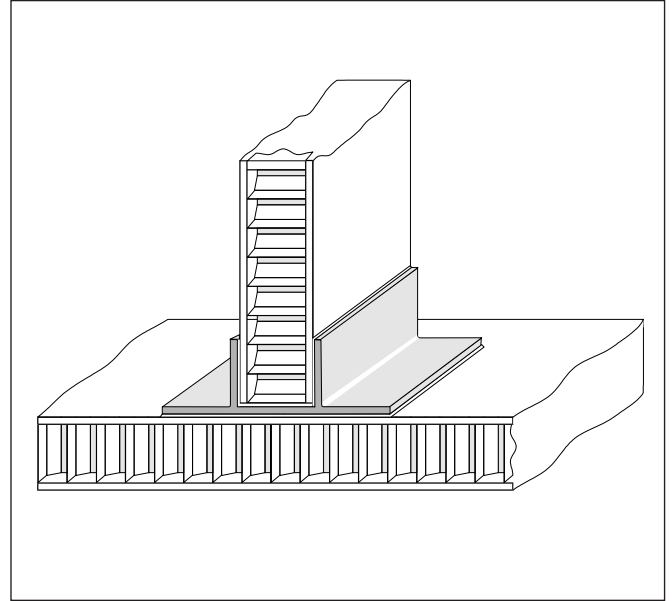

■ Joint supported by special bonded extrusion - for volume production.

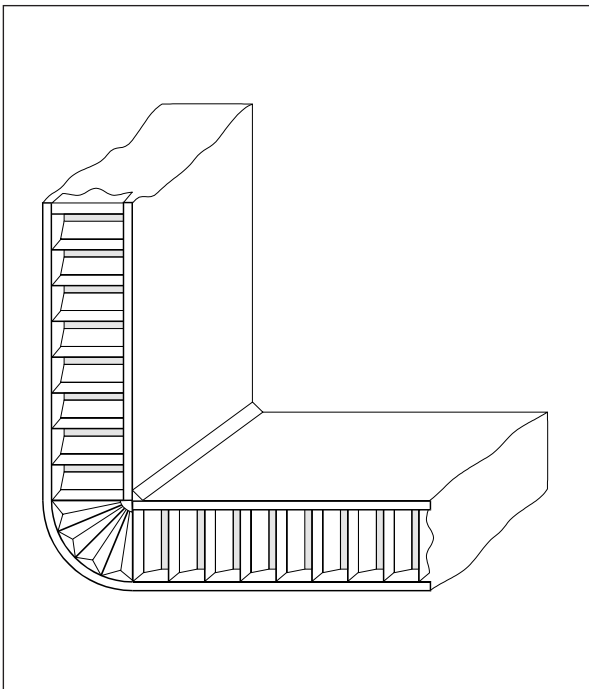

■ Cut, folded and bonded corner joint for clean radius edges.

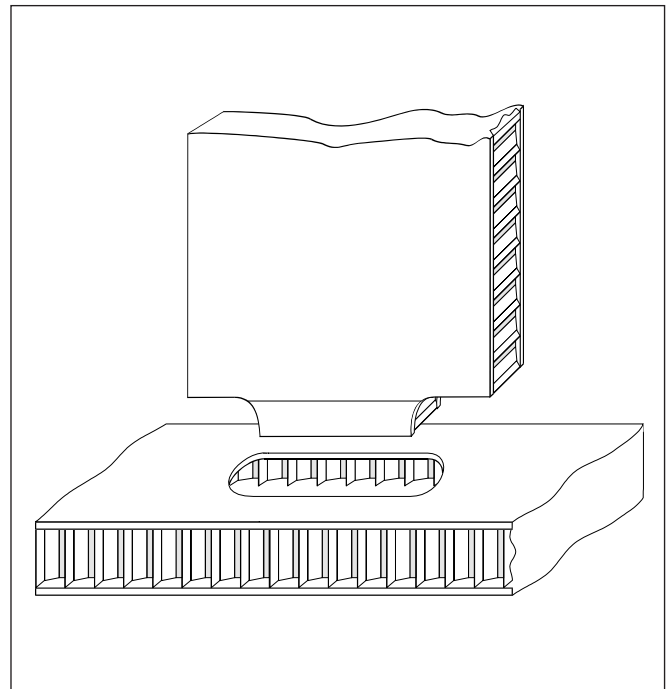

■ Self jigging "tongue and groove" method joint.

When bonding follow instructions on product information sheets. It is advisable to leave neat fillets of adhesive to add strength to the joint.

SANDWICH PANEL FABRICATION TECHNOLOGY

TYPICAL SANDWICH PANEL EDGE CLOSURE METHODS

Open edges on sandwich panels can be sealed to prevent moisture ingress, to enhance appearance or permit subsequent fixings. Some typical edge closure methods are illustrated below:

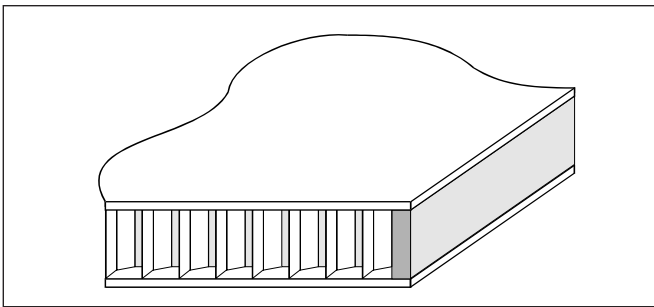

■ Edge filler

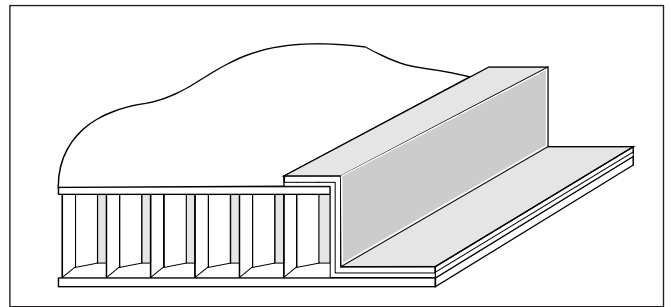

■ Bonded 'Z' section

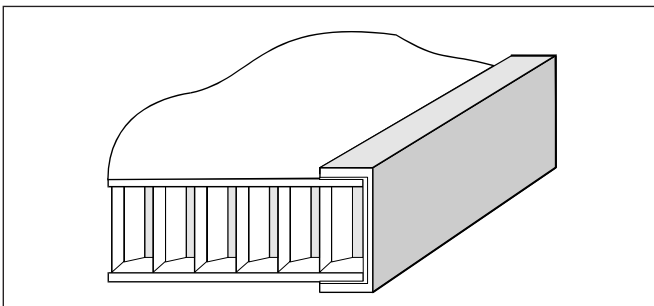

■ Bonded 'U' section

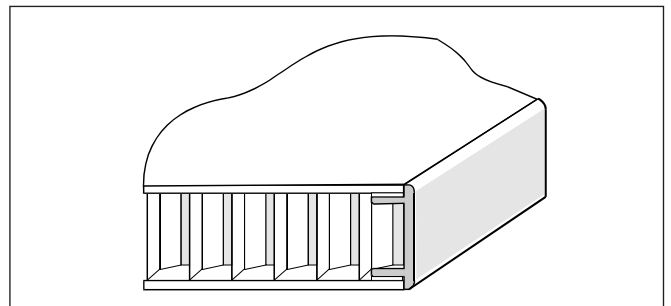

■ Bonded edge closure section suitable for thicker panels

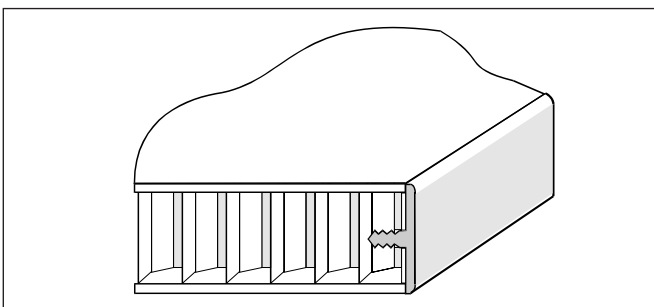

■ Press fit edge closure section, suitable for thinner panels

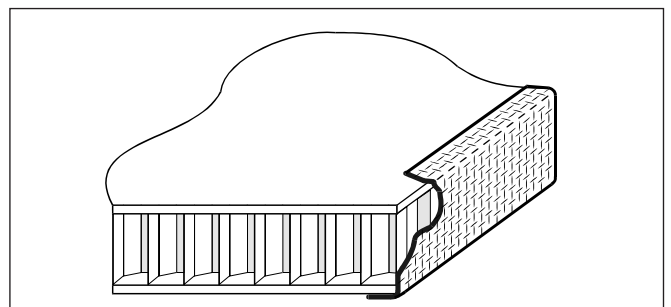

■ Durable self adhesive tape

TYPICAL PANEL FIXINGS

Mechanical fixing to panel faces is achieved in a variety of ways. The choice of method depends on the desired strength, the finish required and the quantity to be produced. To obtain the full strength potential it is necessary to achieve a bonded shear connection to both facing skins.

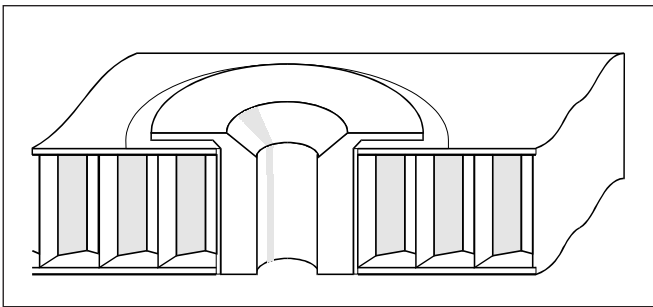

■ Single part ferrule

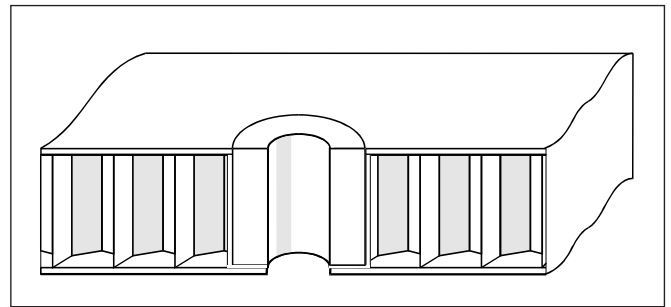

■ Distance tube

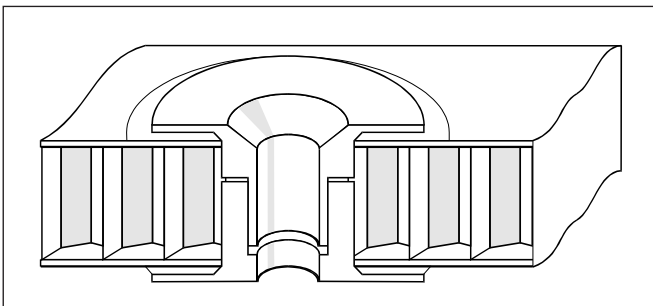

■ Two part ferrule

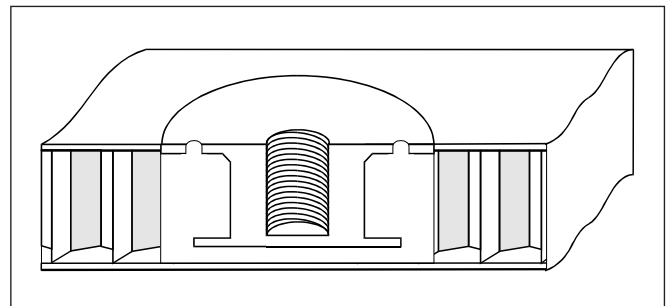

■ Threaded insert

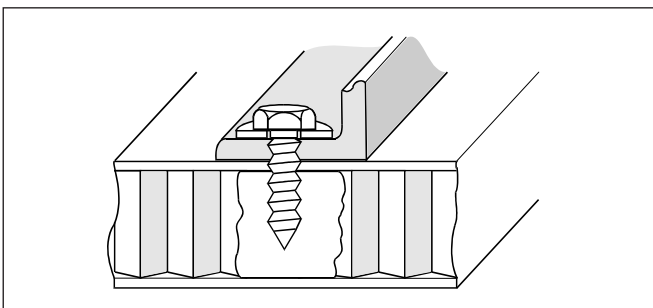

■ Resin potted area

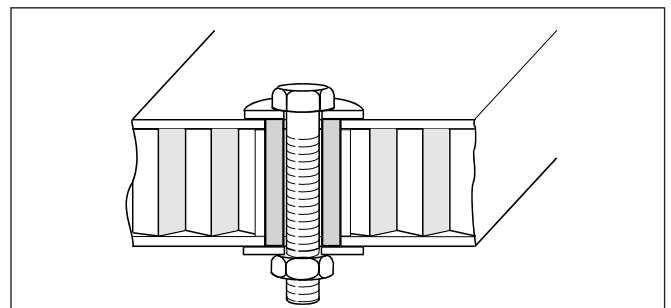

■ Through panel distance tube using penny washer

SANDWICH PANEL FABRICATION TECHNOLOGY

CUT AND FOLD FABRICATION

Most Hexcel Composites honeycomb sandwich panels can be fabricated to form mechanically strong components by following the “cut and fold” technique.

This method is economical, simple, and requires the very minimum in jigs and fixtures - many assemblies can be designed as self-jigging.

The process starts with the removal of a strip ‘x’ from one facing skin. The width is determined by the fold angle required. This is calculated as

$$x = \frac{2\pi \times T \times \theta^\circ}{360}$$

It is advisable to carry out a test fold to verify calculation and assess suitability of materials.

After the strip of skin is removed, adhesive is applied to the exposed core. The component is then clamped until the adhesive cure is complete.

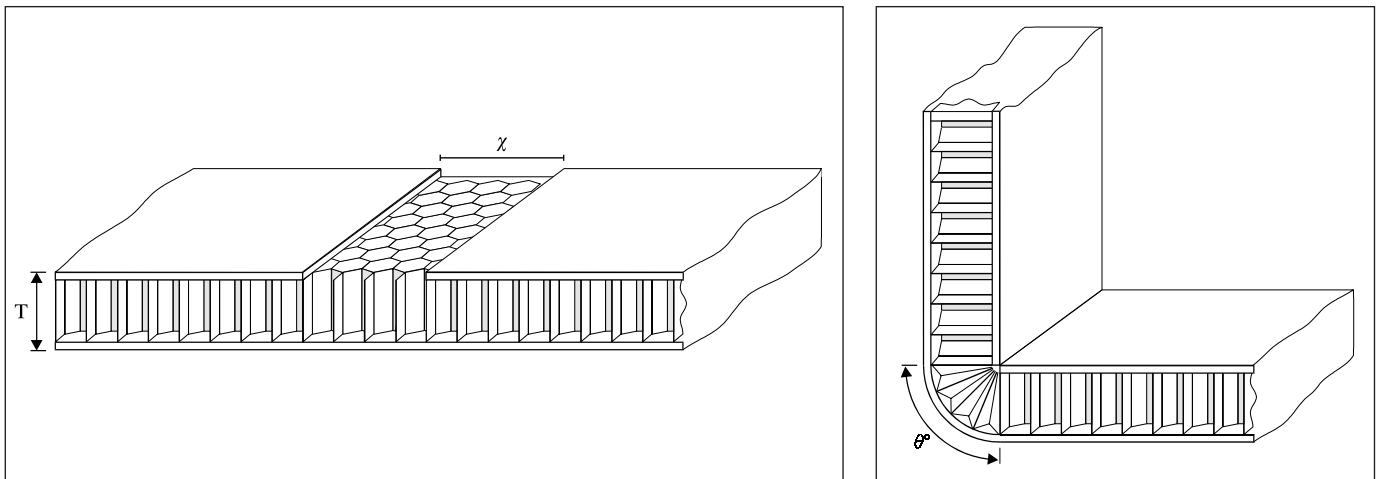

The principle can be applied to most angles.

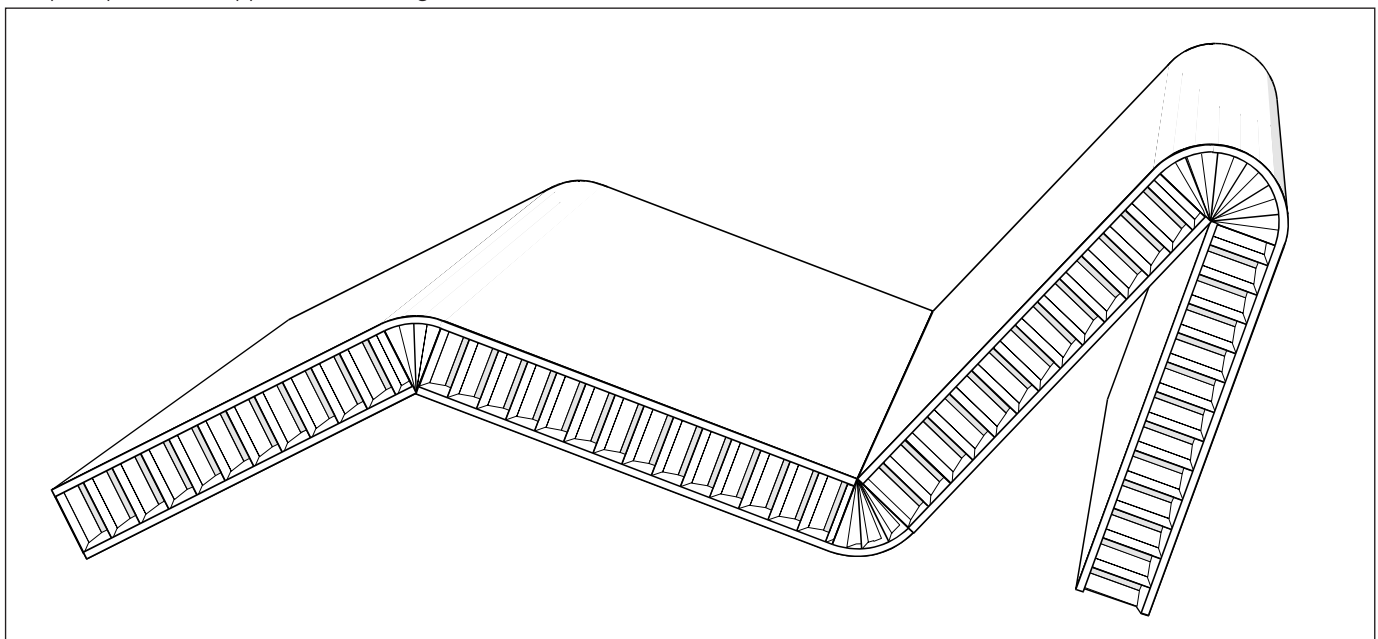

Radius curvature on panel materials can also be achieved using the “cut and fold” technique. In this case narrow, parallel slots are cut through one facing skin.

The number of slots required is determined by the calculation:

$$\frac{\text{Length of outer circumference (C2) - length of inner circumference (C1)}}{\text{thickness of cutter}}$$

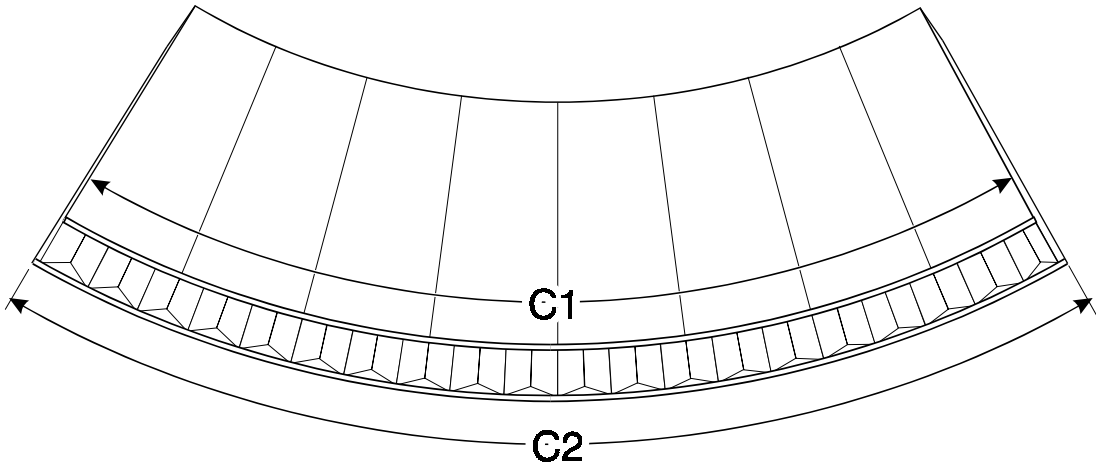

Honeycomb sandwich panels can be cut, folded and bonded to form prefabricated production components with the minimum of tooling.

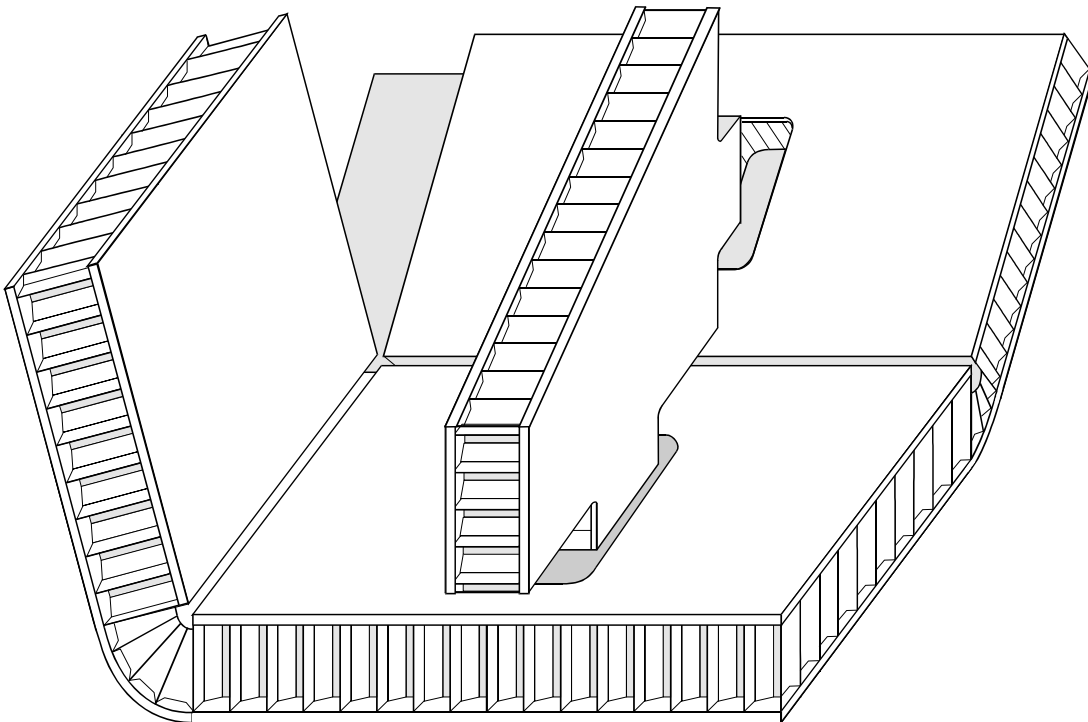

SANDWICH PANEL FABRICATION TECHNOLOGY

TOOL REQUIREMENTS FOR SANDWICH PANEL FABRICATION

Typical Tools and Equipment

Honeycomb sandwich panels can be machined using a variety of power driven tools commonly found in the light metal-working and joinery industries.

For short run production or one-off fabricated components, cutting with hand held tools against a guide or simple template is adequate. When series production is required, use of a numerically controlled machine is beneficial.

Selection of the most suitable cutting tool, cutting speed and feed rate ensures the production of a well-finished component, and gives longer life to the tools.

Some of the tools and equipment used in the fabrication of honeycomb sandwich panel components

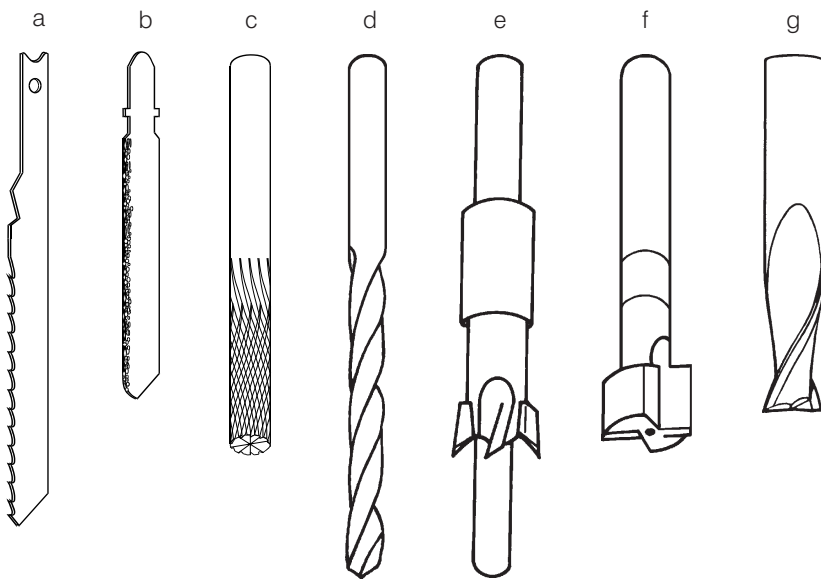

- a Standard jig saw blade
- b Grit edged jig saw blade
- c Diamond cut pattern tungsten carbide router cutter - burr end
- d High speed twist drill
- e Piloted counter bore cutter
- f Edge rebating router cutter
- g 2 flute tungsten carbide router cutter

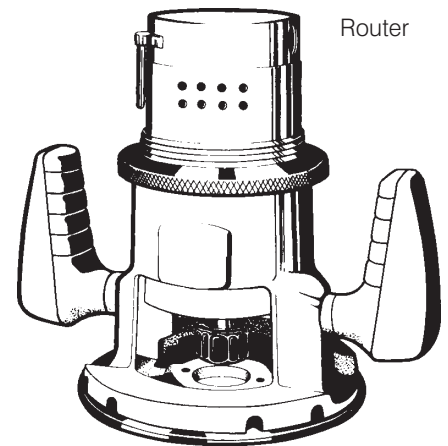

Prior to fabrication of components a trial cut of the panel material is advisable.

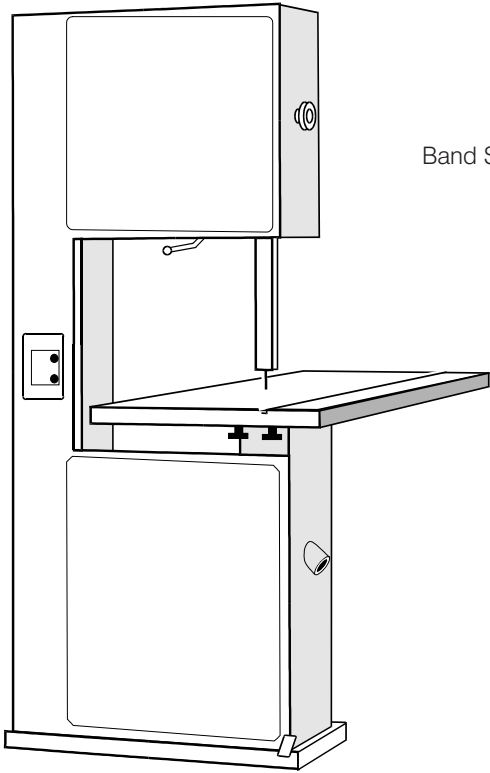

Band Saw

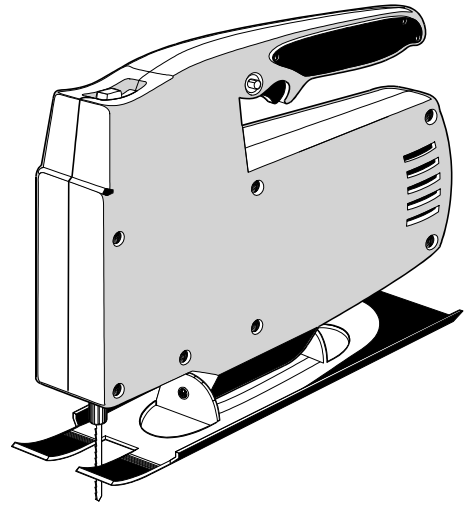

Jig Saw

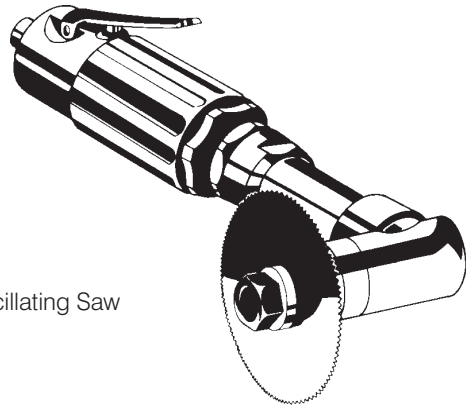

Oscillating Saw

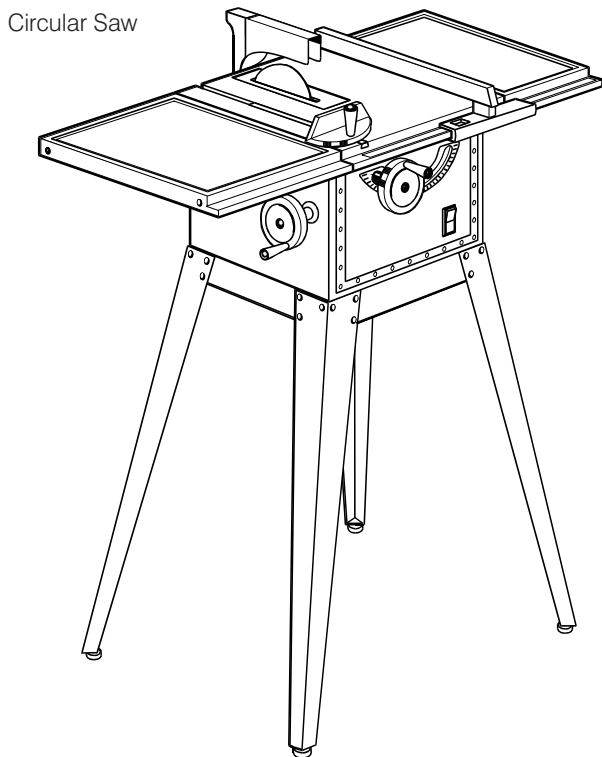

Circular Saw

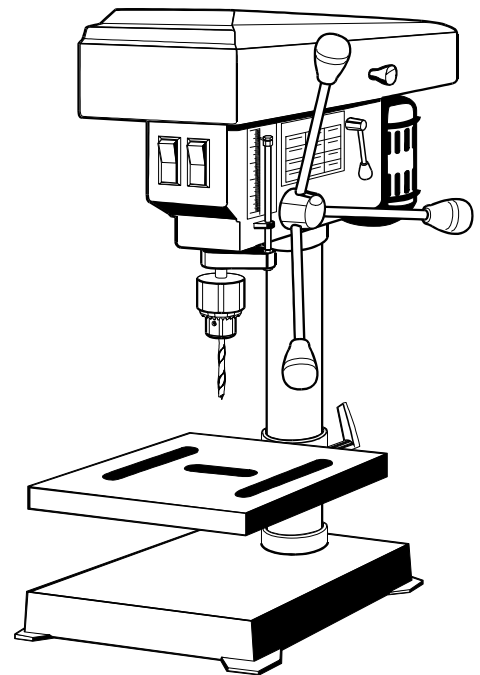

Pillar Drill

SANDWICH PANEL FABRICATION TECHNOLOGY

Cutting/Drilling Summary Table

Different tools are required for cutting and drilling, depending on the panel skin type.

The tables below indicate the tools and techniques to use for panels with fibrous skins and panels with aluminium skins.

Panels with Fibrous Skins

Routing				
Cutter	Dia mm	Speed rpm	Feed mm/min	
			XY Axis	Z Axis
diamond pattern burr router	6.35	18000	2000	450
polycrystalline diamond cutter	6.35	25000	2000	450

Sawing	
Saw Type	Blade Type
band saw	diamond or carbide grit edged blades should be used. speed: 1700 surface m/min feed: 1 m/min
jig saw	
circular saw	
oscillating saw	diamond coated disc

Drilling			
Drill	Dia mm	Speed rpm	Feed mm/min
high speed steel twist drill	X	3500	250
diamond pattern burr router	X	18000	250
tungsten carbide counterbore*	X	3500	250

X = diameter to suit pilot hole or ferrule sizes as applicable
* cut skin from outside face.

Panels with Aluminium Skins

Routing				
Cutter	Dia mm	Speed rpm	Feed mm/min	
			XY Axis	Z Axis
2 flute router	6.35	18000	1200	450

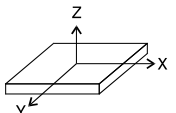

Sawing	
Saw Type	Blade Type
band saw	blade for aluminium (24 tpi) speed: 1700 surface m/min feed: 1 m/min
jig saw	
circular saw	

Drilling			
Drill	Dia mm	Speed rpm	Feed mm/min
high speed steel twist drill*	X	3500	250
tungsten carbide counterbore*	X	3500	250

X = diameter to suit pilot hole or ferrule sizes as applicable
* cut skin from outside face.

CLAMPING SANDWICH PANELS FOR BONDED JOINTS

When producing bonded joints a suitable adhesive should be used, and the construction should be clamped to secure joints until the adhesive cure is complete. The drawings below illustrate appropriate clamping methods.

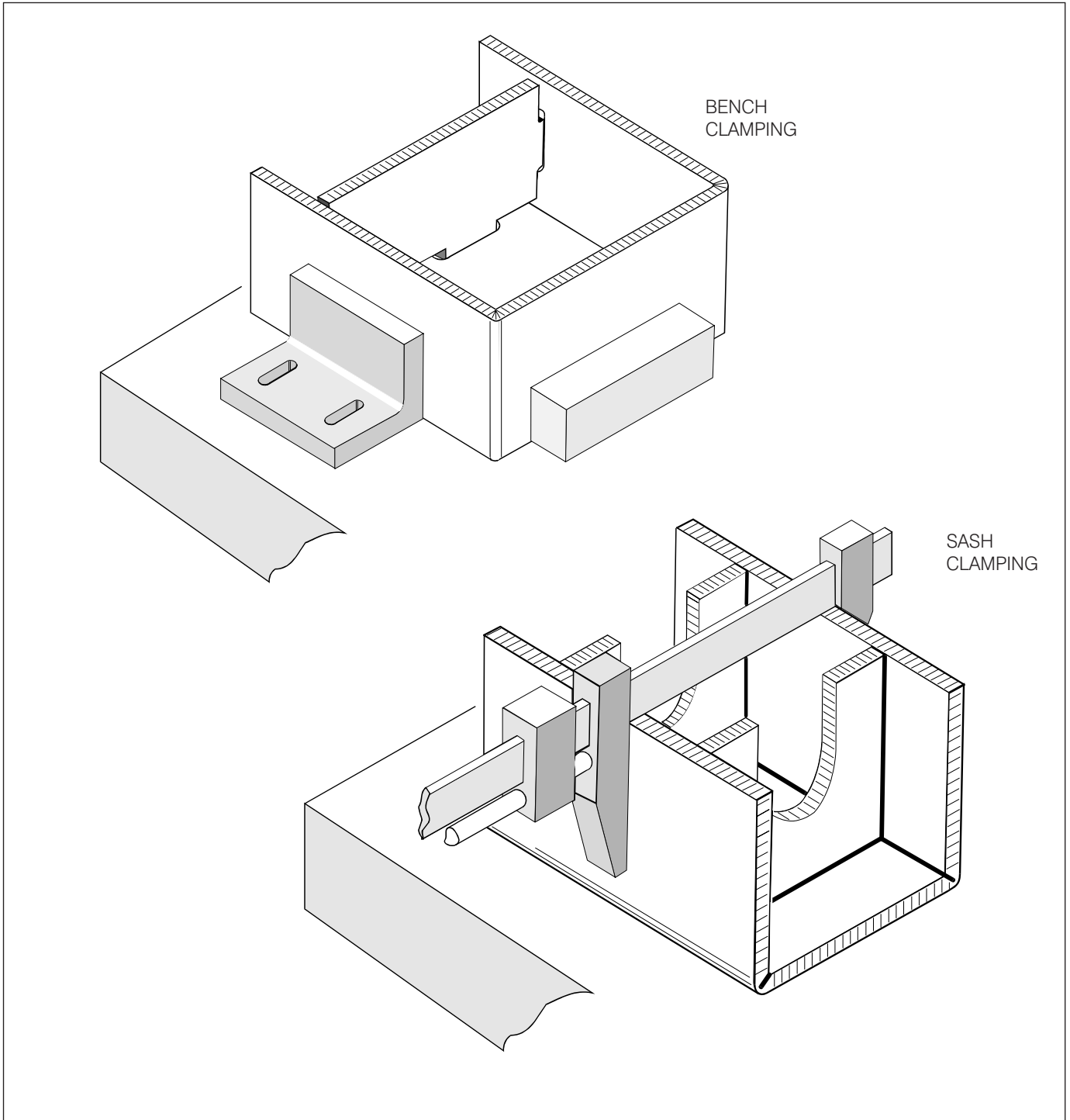

SANDWICH PANEL FABRICATION TECHNOLOGY

HONEYCOMB SANDWICH PANEL FINISHING METHODS

Hexcel Composites panels can, if required, be finished or protected by a wide variety of methods.

PAINT FINISHING	For aluminium face skin panels: Degrease. Self etch prime followed by standard paint specification treatment.	For woven and UD fibrous faced panels: Degrease, lightly abrade surface and fill to obtain a smooth finish as required, followed by standard paint specification treatment.
DECORATIVE FINISHES: e.g. - MELAMINE - WOOD VENEER - TEDLAR® - FABRICS - LEATHER - STONE	Degrease all surfaces to be bonded with an approved degreasing solvent which will not damage the material surfaces. Filling of fibrous faced panels may be necessary if thin decorative finish materials are to be used. Light abrading is recommended. Care must be taken not to abrade severely as this could damage the surface fibres. Ensure that all surfaces are dust free. A second degreasing process is advisable. Bond decorative finish to panel face using epoxy, polyurethane or resorcinol adhesive systems as appropriate. Bond under warm press pressure if possible. Porous or absorbent decor materials can be bonded using rubber based or polyurethane adhesive systems.	

The production of a test piece is advisable before completing any finishing operation, follow the adhesive manufacturer's recommendations.

WARNING: If decorative surfaces are to be applied to sandwich panels with contact adhesive, use ONLY petroleum or emulsion based adhesives. DO NOT use adhesives based on ketones or esters (acetates).

Hexcel Composites Technical Support can offer advice on suitable adhesives for sandwich panel fabrication (contact details are included on the back cover of this brochure).

SAFETY

Handling Precautions

When fabricating from honeycomb sandwich panel materials it is advisable to wear disposable clean cotton gloves throughout the entire operation. This helps to keep the panel clean, and affords protection for the operator's hands.

Glass fibre dust is an irritant. Avoid breathing the dust generated by cutting operations, and do not rub the eyes with hands which may be contaminated with the dust.

The usual precautions should be observed while working with synthetic resins.

Product Safety Data Sheets have been prepared for all Hexcel Composites products and are available to company safety officers on request.

The information contained herein is believed to be the best available at the time of printing but is given without acceptance of liability, whether expressed or implied, for loss or damage attributable to reliance thereon. Users should make their own assessment of the technology's suitability for their own conditions of use and, before making any commitment with regard to the information given, should check that it has not been superseded.