

COMBIVERT



POWER STAGE INSTRUCTION MANUAL

00.F5.0UB-K001



Read this instruction manual completely before attempting to operate the unit!



05/2003

This Instruction Manual describes the power circuit of the KEBCO COMBIVERT F5 Series Motor Control. It is only valid together with the Instruction Manual Control Stage. Both Instruction Manuals must be made available to the user. Prior to performing any work on the unit the user must familiarize himself with the unit. This includes especially the knowledge and observance of the **safety and warning information on page 5 of this book**. The pictographs used in this Instruction Manual have following meaning:



**Danger
Warning
Caution**



**Attention,
observe at
all costs**



**Information
Help
Tip**

Table of Contents

1. General	4		
1.1 Product description	4		
1.2 Safety Precautions	5		
1.3 Part number system	6		
1.4 Mounting instructions	7		
1.4.1 Classification	7		
1.4.2 Physical Mounting	7		
1.4.3 Harsh Environments	7		
1.4.4 Ambient Conditions	8		
1.4.5 Cooling systems	8		
1.5 Electrical connections	9		
1.5.1 Safety First	9		
1.5.2 Voltage Supply	9		
1.5.3 Disconnect Switch	9		
1.5.4 Fusing	10		
1.5.5 Line Chokes	10		
1.5.6 Motor Thermal Protection	11		
1.5.7 High Voltage Connections	11		
1.5.8 DC Supply Connections	12		
1.5.9 Ground Connections	12		
1.5.10 High Frequency Shielding	13		
1.5.11 Example shield connections	14		
1.5.12 Example Control Cabinet Layout	14		
2. Technical Data	15		
2.1 Technical Data 230V Class	15		
2.2 Technical Data 460V Class	17		
2.3 Dimensions and Weight	21		
2.4 Survey of Power Circuit Terminals	22		
2.5 Connection of Power Circuit	24		
3. Accessories	26		
3.1 Braking Resistor	26		
3.1.1 Selection of the Braking Resistor	26		
3.1.2 Panel Mount Brake Resistors ...	28		
3.1.3 Parallel Connection of Braking Resistors	30		
3.1.4 Back Mount Braking Resistor ...	31		
3.2 Input Filters	33		
3.2.1 Line Choke	33		
3.2.2 EMI (CE) - Filter	36		
3.3 Output Filters	39		
3.3.1 Motor Choke	39		
3.3.2 PWM to Sine Filter	42		
3.3.3 PWM to Sine Filter Plus	42		
4. Annex	43		
4.1 Overload Characteristic	43		
4.2 Overload protection in the lower speed range	43		

1. General

1.1 Product description

In selecting the COMBIVERT F5 series inverter, you have chosen a frequency inverter with the highest quality and dynamic performance.



It is exclusively designed for smooth speed regulation of a three phase motor.



The operation of other electrical loads is forbidden and can lead to destruction of the unit.

This manual describes the frequency inverter **COMBIVERT F5**.

- 1 hp...60 hp / 230V class

- 1 hp...200hp / 460V class



Note: 250hp to 450hp units, sizes 28 - 31 are described in a supplemental manual 00.F4.0UZ-KW01. For technical data and wiring connections of these sizes please consult this document.

The COMBIVERT F5 inverter has the following features:

- small mounting footprint
- IGBT power circuit gives low switching losses
- low motor noise with high carrier frequency
- extensive protection for over- current, voltage and temperature
- voltage and current monitoring in static and dynamic operation
- short circuit proof and ground-fault proof
- noise immunity in accordance with IEC1000
- hardware current regulation
- integrated cooling fan
- uniform mounting pattern
- can be mounted side by side with zero clearance
- CE compliant and UL listed

1.2 Safety Precautions



Danger to Life

AC motor controls and servo drives contain dangerous voltages which can cause death or serious injury. During operation they can have live "energized" un-insulated parts, moving parts, as well as hot surfaces. Care should be taken to ensure correct and safe operation in order to minimize risk to personnel and equipment.



Only Qualified Personnel

All work involving this product, installation, start up as well as maintenance may only be performed by qualified electrical technical personnel. According to this manual "qualified" means: those who are able to recognize and acknowledge the possible dangerous conditions based on their training and experience and those who are familiar with the relevant standards and installation codes as well as the field of power transmission.



Protect Against Accidental Contact

AC motor controls and servo drives must be protected against physical damage during transport, installation, and use. Components or covers must not be bent or deformed as this may decrease insulation distances inside the unit resulting in an unsafe condition. On receipt of the unit visual damage should be reported immediately to the supplier. **DO NOT ATTEMPT TO POWER UP A UNIT WITH VISIBLE PHYSICAL DAMAGE.** This unit contains electrostatically sensitive components which can be destroyed by incorrect handling. For that reason, disassembly of the unit or contact with the components should be avoided.



Note Capacitor Discharge Time

Before any installation and connection work can be done the supply voltage must be turned off and locked out. After turning off the supply voltage, dangerous voltages may still be present within the unit as the bus capacitors discharge. Therefore it is necessary to wait 5 minutes before working on the unit after turning off the supply voltage.



Secure Isolation

The low voltage control terminal strip and communication ports are securely isolated in accordance with EN50178. When connecting to other systems, it is necessary to verify the insulation ratings of these systems in order to ensure the EN requirements are still met. When connecting the unit to a grounded delta power system, the control circuit can no longer be classified as a "securely isolated circuit".



Damage to Property and Injury to Persons

Before putting the motor control or servo system into operation be sure the connection terminals are tight and all covers removed for installation have been replaced.



Redundant Safety Mechanisms

Software functions in the AC motor control or servo system can be used to control or regulate external systems. However, in the event of failure of the motor control or servo system there is no guarantee these software function(s) will continue to provide the desired level of control. As a result, when operator or machine safety is at stake, external elements must be used to supplement or override the software function within the AC motor control or servo system.

1.3 Part number system

10.F5.G1B-3200

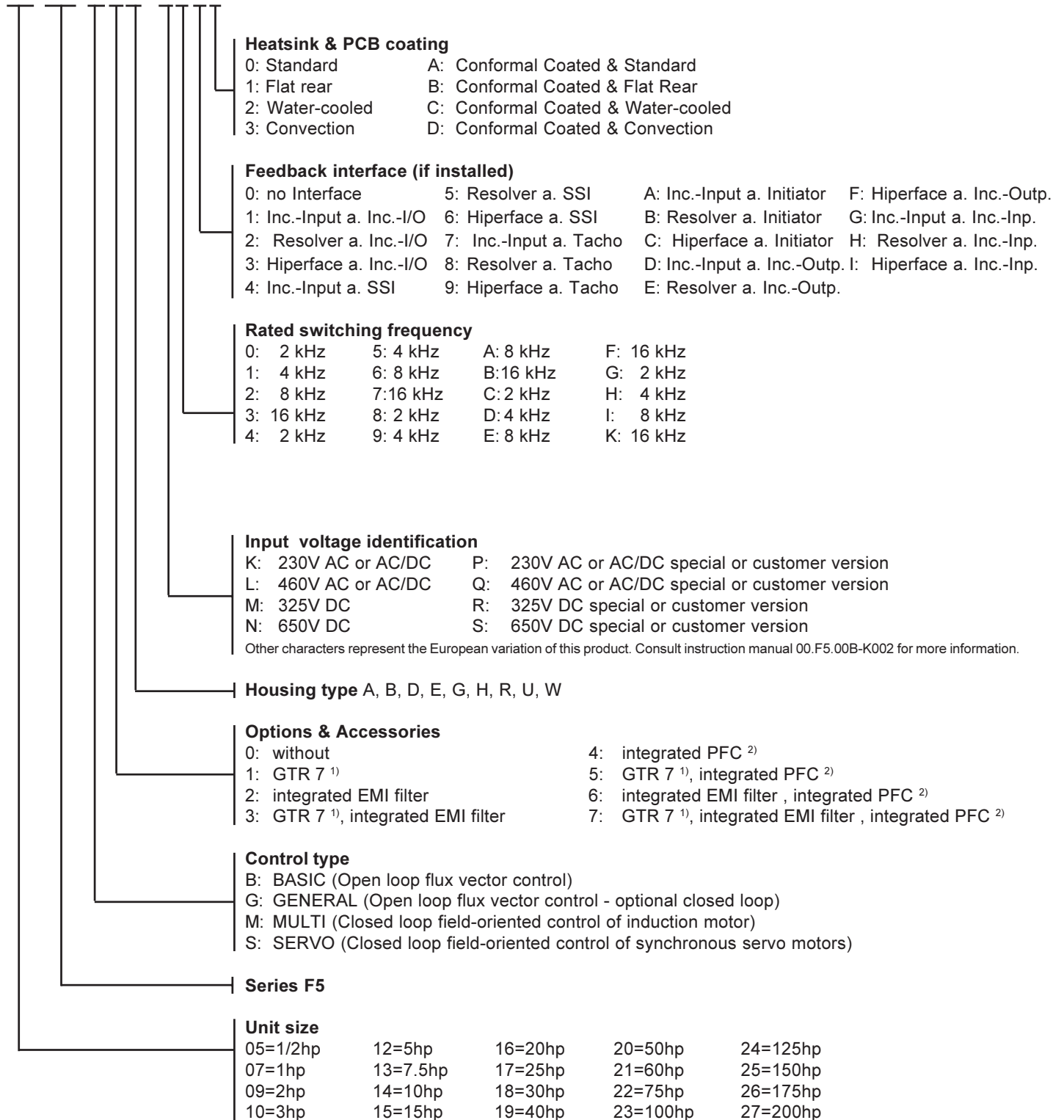

1) GTR 7: brake transistor

2) PFC: Power Factor Control

1.4 Mounting instructions



1.4.1 Classification

- The COMBIVERT F5 is classified as an "Open Type" inverter with an IP20 rating and must be mounted inside of a control cabinet.

1.4.2 Physical Mounting

- Install the inverter in a stationary location offering a firm mounting point with low vibration.
- Installation of the inverter on moving system may require special earth ground connections to the inverter. Please consult KEBCO.
- For best high frequency grounding, install the inverter on a bare metal sub-panel, i.e. zinc plated steel or galvanized steel.
- Take into consideration the minimum clearance distances when positioning the inverter (see drawing below). The F5 series inverters are designed for vertical installation and can be aligned next to each other. Maintain a distance of at least 2 inches in front of the unit. Make sure cooling is sufficient.

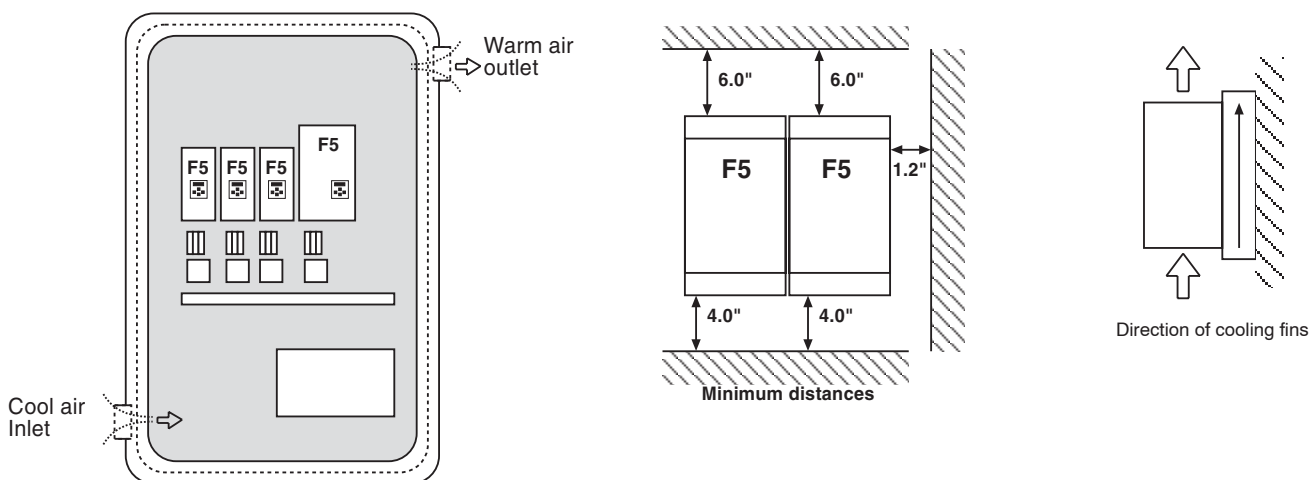

1.4.3 Harsh Environments

- For extended life, prevent dust from getting into the inverter. Select units with conformal coating when the inside of the control cabinet may be occasionally subject dust, moisture, or other substances which could build up over time.
- When installing the unit inside a sealed enclosure, make sure the enclosure is sized correctly for proper heat dissipation or that a cooling system has been installed in the panel.
- Protect the inverter against conductive and corrosive gases and liquids. Water or mist should not be allowed into the inverter.**
- The COMBIVERT F5 inverter must be installed in an explosion-proof enclosure when operating in an explosion-proof environment.**





1.4.4 Ambient Conditions

- The operating temperature range of the unit is -10°C to + 45°C. Operation outside of this temperature range can lead to shut down of the inverter.**
- The unit can be stored (power off) in the temperature range -25°C to 70°C. After prolonged storage, one half year or more, apply voltage to the inverter for 2 hours before operating the motor. This will allow the electrolytic bus capacitors to stabilize before use and result in longer lifetime of the unit.
- The power rating of the inverter must be derated for operation above 3,300 ft (1000 m). Reduce the rated power 1% for each additional 330 ft (100 m). The maximum elevation for operation is 6,560 ft (2000 m)
- The relative humidity should be limited to 95% without condensation.

1.3.5 Cooling systems

The KEB COMBIVERT F5 is available with different cooling systems:

- Standard** - Standard design with heat sink and thermostatically controlled two speed fan.
- Flat Back** - With this design the heat sink is omitted. The unit must be mounted onto an appropriate base (a machined surface) to ensure heat removal from the inverter. The dissipation of the heat must be guaranteed by the machine builder. Advantages include: low profile for intermittent duty controls, heatsink sharing, modular assembly.
- Water-cooling** - This design is laid out for connection to an existing cooling system. The dissipation of the heat must be guaranteed by the machine builder. To avoid moisture condensation, the minimum inlet temperature of the coolant may not fall below the room temperature. The maximum inlet temperature shall not exceed 40°C. Measures must be taken to prevent contamination and calcifying buildup within the cooling system. The maximum pressure on the cooling system shall not exceed 4 bar (60 psi (special versions with higher pressures on request). The standard water pipe fitting is G1/2.
- Convection (push through version)** - The heat sink is over sized and designed to push through the cabinet wall to the outside. The smaller units (<40hp) generally will operate without additional air flow through the heatsink. The larger units will require some type of forced airflow through the heatsink.

1.5 Electrical connections

1.5.1 Safety First



- RISK OF ELECTRIC SHOCK!** Always disconnect supply voltage before servicing the COMBIVERT F5.
- After disconnecting the supply voltage, always wait 5 minutes before attempting to change the wiring. The internal DC BUS capacitors must discharge.

1.5.2 Voltage Supply

- The F5 series inverters are suitable for use on a circuit capable of delivering not more than 10kA rms symmetrical amperes, at the inverter's rated maximum voltage.
- Pay attention to the supply voltage and be sure the supply voltage matches that of the inverter. A 230V unit can be supplied with voltage in the range 180 to 260VAC +/-0%, for a 460V unit the range is 305 to 500VAC +/- 0%, 48Hz to 62 Hz.



- Connection of the F5 series inverters to voltage systems configured as a corner grounded delta, center tap grounded delta, open delta, or ungrounded delta, may defeat the internal noise suppression of the inverter and the isolation of the control part is no longer classified as a "securely isolated circuit". Increased high frequency disturbance in the machine and on the line may be experienced. On such a system the maximum allowable phase to ground voltage is 500VACrms. A balanced, center grounded wye connection is always recommended. The three phase voltage imbalance must be less than 2% phase to phase. Greater imbalance can lead to damage of the inverter's power circuit.**

1.5.3 Disconnect Switch

- A disconnect switch or contactor should be provided as a means of turning off the supply voltage when the unit is not in use or when it must be serviced.
- Repetitive cycling on and off of the input supply voltage more than once every five minutes can lead to damage of the inverter. For shorter times contact KEBCO.



- A disconnect or switch placed between the motor and inverter should be avoided if at all possible. However, if not, the following points should be considered. It is not allowed to actively switch the motor on a closed loop (Field Oriented Control induction or AC servo) system. The inverter must first be brought into NOP status by turning off the drive enable input on terminal X2.16. On openloop systems, switching off a motor running under load can cause the COMBIVERT F5's overcurrent protection to activate resulting in a fault shut down of the unit. When starting motors by closing the contact into an already running inverter, the inverter should be sized based on the starting current of the motor. Or to reduce the current demand, the "speed search" function of the inverter should be activated.**



1.5.4 Fusing

- A circuit breaker or a disconnect switch with fuses must be provided as branch circuit protection in accordance with the National Electric Code (NEC) and all local codes.
- The F5 is to be connected to the supply voltage using Class J fuses (BUSSMANN type LPJ or equivalent) or using a magnetic trip circuit breaker with type D characteristic. Ratings for the short-circuit protection device are specified per unit size in the tables on pages 15-20.
- The minimum voltage rating for protection devices used with 230V inverters shall be 250VAC. The minimum voltage rating for protection devices used with 460V inverters shall be 600VAC.
- Fuses should not be installed between the inverter and the motor. The output of the inverter is short circuit protected and ground fault protected with a maximum trip value (varies by housing size) of 250% of the rated output current. The tripping time is less than 1 mSec. Repeated short-circuits faults can cause premature failure of the output transistors. If the motor is operating in regenerative mode (2nd or 4th quadrant) and a short circuit occurs, the inverter may not be able to limit the current before failure occurs.



1.5.5 Line Chokes

- A line choke with minimum 3% impedance is required for all 230 V inverters 40hp (size 19) and greater. A line choke with minimum 3% impedance is required for all 460V inverters 100hp (size 23) and greater.
- Installing a line choke will considerably extend the lifetime of the DC bus capacitors especially on systems operating continuously at rated power.
- A line choke with minimum 3% impedance should be installed when the power available at the nearest distribution point is significantly greater (more than 200 times) than the rated power of the inverter.



Example: 5 hp COMBIVERT F5 $S_{\text{rated}} = 6.6\text{kVA}$, $S_{\text{dist_xfrmr}} = 2,000\text{ kVA}$.

$$2,000\text{kVA} / 6.6\text{ kVA} = 303 > 200 \rightarrow \text{install 3\% choke}$$

Another method to determine whether a choke is required; if the line impedance is less than 0.5%, then a choke should be used.

- A line choke can be used to generally reduce conducted high frequency noise eliminating nuisance trips. See section 3.2.1 on page 33 for more information.

1.5.6 Motor Thermal Protection

- The F5 series inverters by default provide motor overload protection at 130% of the inverter's UL rated current.
- The F5 series inverters are classified as a UL approved solid state overload protection device. It is necessary to activate the function in the software of the inverter. The function meets the requirements set forth in VDE 0660 Part 104, UL508C section 42, and NEC 430 part C. See parameters dr.11, dr.12 and Pn.14 in the application mode for adjustment.
- Overload protection using a normally closed contact (min. rating 15V 6mA) or PTC type sensor is also available using terminals T1 and T2. This function also must be activated by the software of the inverter. See parameters CP.28 or Pn.10.
- In general, overload protection through current sensing does not always provide protection against overheating at low speeds; reduced fan cooling. Therefore it is recommended that a motor winding sensor be used in applications requiring prolonged operation at low motor speeds.**



1.5.7 High Voltage Connections

- Always note inverter voltage, select appropriate over current protection devices, select disconnect device, and select proper wire size before beginning the wiring process. Wire the inverter according to NEC Class 1 requirements.
- The correct wire gauge for each size inverter can be selected from the charts on pages 15-20. Always use UL listed and CSA approved wire. The wire gauge is based on the recommended fuse rating for the inverter and a minimum of 75°C insulation rating. Use copper wire only. If a lower rated fuse is selected, then it may be possible to use a smaller gauge wire. Use 300V rated wire with 230V systems and 600V rated wire with 460V systems.
- The terminal tightening torque can be found for each unit in the same tables.
- To prevent coupling high frequency noise, the following wires must be spatially separated from each other a minimum distance of 8 inches (20 cm) when they are laid parallel to each other :
 - AC supply power and motor lines not connected to inverters
 - motor lines connected to inverters
 - control and data lines (low-voltage level < 48 V)
- When using KEBCO EMI filters, use only the wire provided with the filter to connect the filter to the inverter. Do not add additional wire between the filter and the inverter as this will have a negative effect on the operation of the filter.

1.5.8 DC Supply Connections

When connecting the F4 series inverter from a DC supply or when connecting several F4 series inverters to a common DC bus the following points should be observed.

- Each inverter must be fused on both the + and - conductors. BUSSMANN DC fuse type FWP are recommended. The DC input current of the inverter can be calculated using the equations below.
- Connect the positive wire to the ++ terminal and the negative wire to the -- terminal. Terminals marked PA, PB, or - are not suited for DC voltage input. See page 24 for wiring example. All previously stated wiring conditions are still valid.
- The peak DC supply current can be calculated with the following formulas:

230V Supply

$$\frac{2.6 \times \text{rated motor voltage} \times \text{rated motor current} \times \text{motor PF}}{310V}$$

460V Supply

$$\frac{2.6 \times \text{rated motor voltage} \times \text{rated motor current} \times \text{motor PF}}{620V}$$

If the motor power factor (PF) is not known, use the value 0.78 as a default.

For additional information about DC supply of the inverter contact KEBCO Inc.

1.5.9 Ground Connections

- When working with high frequencies (> 1kHz) and power semiconductors it is recommended to make all ground connections with large exposed metal surfaces in order to minimize the ground resistance.
- The metal sub-plate the inverter is mounted on is regarded as the central ground point for the machine or the equipment. For best results use an unpainted, galvanized or plated sub-panel.
- The AC motor control or servo system is designed for fixed installation. High frequency discharge currents in the ground circuit can exceed 3.5mA especially when using EMI filters. Therefore, an additional high frequency ground wire should be connected between the inverter and the sub-panel. Use a stranded wire (6 gauge) or a thick ground strap. This is in addition to the ground wire required by NEC.**
- All ground connections should be kept as short as possible and as close as possible to the ground system, sub-panels.
- If other components in the system exhibit problems due to high frequency disturbances, connect an additional high frequency ground wire between them and the sub-panel.
- The KEBCO EMI filter should be mounted to the inverter or as close as possible to the inverter and on the same sub-panel as the inverter. Good metallic surface contact to the sub-panel is required to provide adequate high frequency grounding of the filter.



1.5.10 High Frequency Shielding



- Use of shielded cable is recommended when high frequency emissions or easily disturbed signals are present. Examples are as follows:
 - **motor wires connected to inverters:** connect shield to ground at both the inverter and motor, NOTE the shield should never be used as the protective ground conductor required by NEC. Always use a separate conductor for this.
 - **digital control wires:** connect shield to ground at both ends.
 - **analog control wires:** connect shield to ground only at the inverter.
- The connection of meshed shields to the ground connection should not be done through a single strand of the shield, but with metallic clamps to provide 360° contact around the surface of the shield to the ground point. Connection with a single wire bundle from the braided shield reduces the effectiveness of the shield 70%. Metal conduit clamps work well for this. Be sure the fit is tight.
- Ridged metal conduit can be used as the shield of the motor wires. Always observe the following points :
 - **remove all paint** from the control cabinet and motor housing where the conduit is fastened
 - **securely fasten** all conduit fittings
 - **run only the motor wires through the conduit**, all other wires, high voltage AC and low voltage signal, should be pulled through a separate conduit.
 - **connect the control panel to the Sub-panel** with a heavy ground strap.
- If KEBCO CE filters are used, they should be mounted to the inverter or as close as possible to the inverter and on the same sub-panel as the inverter. Good metallic surface contact to the sub-panel is required to provide adequate high frequency grounding of the filter. Always use the shielding plate provided with the filter when connecting the filter to the inverter.
- Shielding of control wires:
 - If digital signal wires are terminated on a terminal block in the control panel, the shields should be firmly connected to the sub-panel on both sides of the terminal block.
 - The shields of digital signal wires originating outside the control cabinet which are not terminated on a terminal block, must be connected to the sub-panel at the point where the cable enters the control panel and at the inverter.
 - If the shield is terminated to the sub-panel within 8 inches (20cm) of the inverter, then the shield no longer needs to be connected to the inverter.
 - When using un-shielded signal wires, they should always be installed as a twisted pair (signal and common).
 - Low voltage signal wires should cross high voltage wires at right angles.

1.5.11 Example shield connections

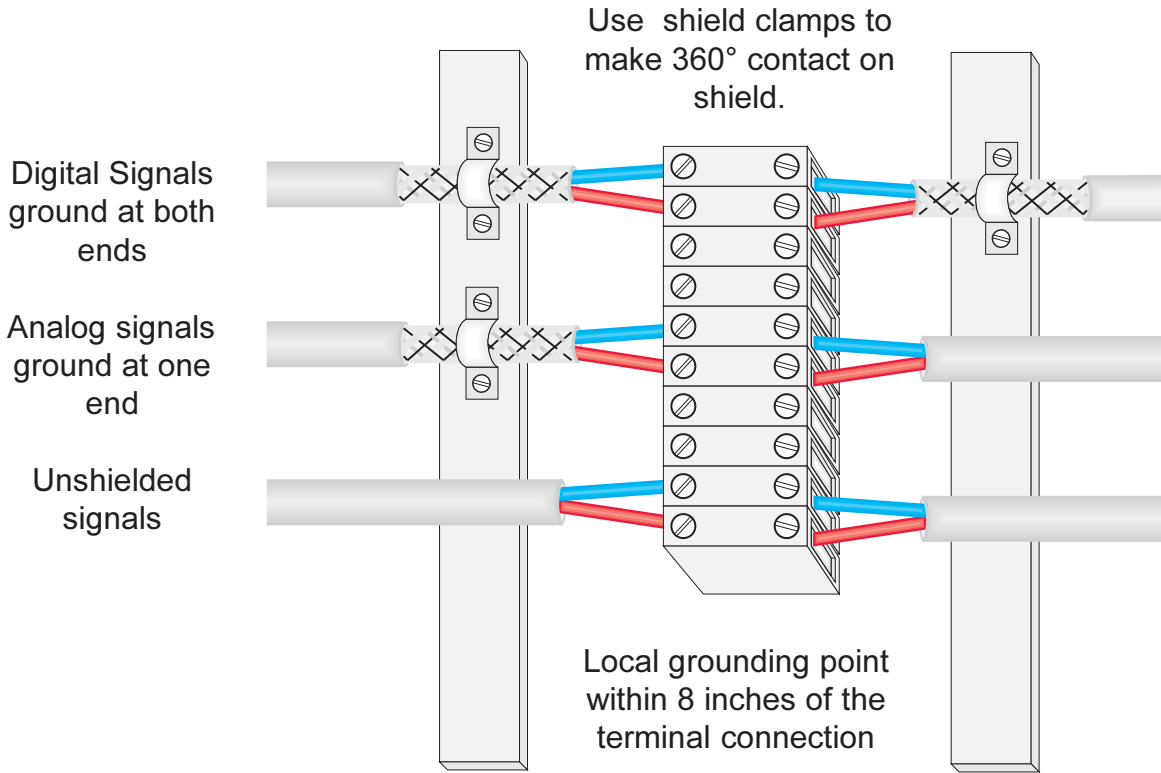

1.5.12 Example control cabinet layout

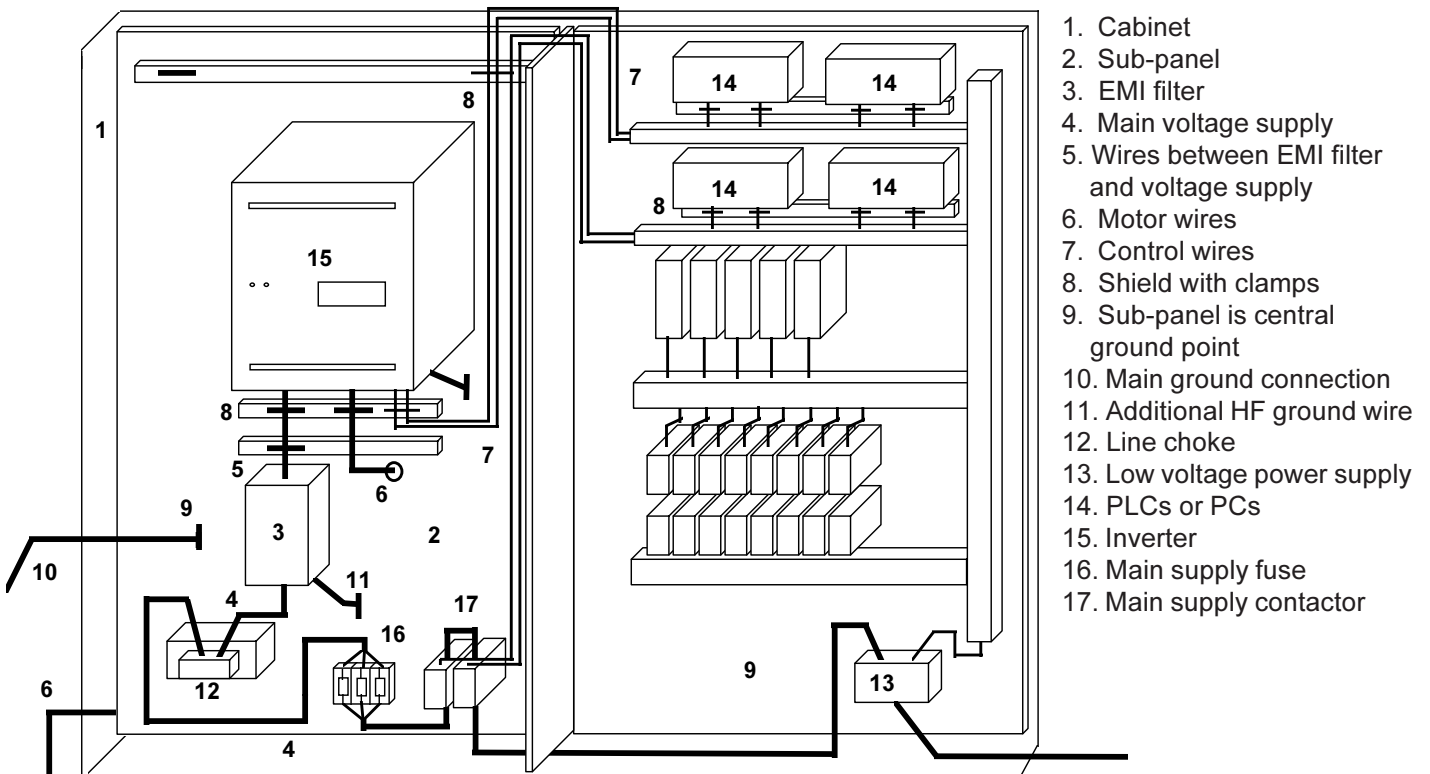

2. Technical Data

2.1 Technical Data 230V Class

Inverter Size	05			07			09			10			12	13	14			
Recommended Motor Power [hp]	1/2			1			2			3			5	7.5	10			
Housing size	A	B		A	B		B		D		B		D		D	E	E	G
Input Ratings																		
Supply voltage [V]	180...260 ±0 (230 V rated voltage)																	
Supply voltage frequency [Hz]	50 / 60 +/- 2																	
Input phases	1	1	3	1	1	3	1	3	1	3	1	3	1	3	3	3	3	
Rated input current [A]	4,0	4,0	2,8	8,0	8,0	5,6	14	9,5	14	9,5	19	13	19	13	21	29	36	
Rated input current ²⁾ [A]	–	3,2	–	–	6,4	–	–			–			–	–	–			
Rated input "real" power ²⁾ [kW]	–	0,85	–	–	1,5	–	–			–			–	–	–			
Recommended maximum input fuse [A]	15			15	15	15	20	15	20	15	25	20	25	20	25	35	50	
Recommended wire gauge ³⁾ [awg]	14			14	14	14	12	14	12	14	10	12	10	12	10	10	8	
Output Ratings																		
Rated output power [kVA]	0,9			1,6			2,8			4,0			6,6	9,5	13			
Rated motor power [kW]	0,37			0,75			1,5			2,2			4,0	5,5	7,5			
Rated output current [A]	2,0			4,0			6,8			9,6			15,2	22	28			
Peak current (30 seconds) ¹⁾ [A]	4,1			7,2			12,6			18			29,7	36	49,5			
Over current fault (E.OC) trip level [A]	5,0			8,6			15,1			21,6			35,6	43	59			
Overload curve (see annex)	1																	
Output voltage [V]	3 x 0...V input (3 x 0...255V ²⁾)																	
Output frequency [Hz]	Generally 0 to 1600Hz (limited by control board and carrier frequency)																	
Rated switching frequency [kHz]	8 ⁸⁾	16		8	16		16			8	16		8	8	4	16		
Maximum switching frequency [kHz]	8	16		8	16		16			16	16		16	16	16	16		
Power loss at rated operation ⁷⁾ [W]	30	50		55	65		90	130		105	170		210	290	350	330		
Power loss at rated operation ²⁾ [W]	–	85	–	–	130	–	–			–			–	–	–			
Stall current at 4kHz [A]	2,3			4			7			10	10		16,5	24	33	33		
Stall current at 8kHz [A]	2,3			4			7			10	10		16,5	24	24	33		
Stall current at 16kHz [A]	–	2,3		–	4		7			8	10		10	16,8	16,8	33		
Braking Circuit																		
Min. braking resistance ⁴⁾ [Ohm]	100	56	100	56	47			33			27	16	16	13				
Typ. braking resistance ⁴⁾ [Ohm]	180	100		100			68			56			47	22	22	16		
Max. braking current [A]	4.5	7.5	4.5	7.5	9.5			12			15	25	25	29				
Installation Information																		
Max. shielded motor cable length at 4 kHz ⁵⁾ [ft]	30	100		30	330		330			330			330					
Max. shielded motor cable length at 8 kHz ⁵⁾ [ft]	30	65		30	165		330			330			330					
Max. shielded motor cable length at 16kHz ⁵⁾ [ft]	–	30		–	65		130			330			330					
Tightening torque for terminal strip [in lb]	4.5														11			
Environmental																		
Max. heat sink temperature TOH [°C]	90°C / 194°F																	
Storage temperature [°C]	-25...70 °C / -13...158°F																	
Operating temperature [°C]	-10...45 °C / 14...113°F																	
Housing design / protection	Chassis / IP20																	
Relative humidity	max. 95% without condensation																	
Approvals																		
Tested in accordance with...	EN 61800-3 /UL508C																	
Standards for emitted interference	EN 55011 Class B / EN 55022 Class A																	
Standards for noise immunity	IEC 1000-4-2 / -3 / -4 / -5/ -6																	
Climatic category	3K3 in accordance with EN 50178																	

- 1) With the regulated systems F5-M as well as F5-S 5% must be subtracted as control reserve
- 2) This data is only valid for units with integrated PFC (see "unit identification")
- 3) The wire gauge is based on the maximum fuse rating, copper wire with minimum 75°C insulation rating, THHW or equivalent. If branch circuit protection is selected based on rated input current, the wire size could be reduced.
- 4) This data is only valid for units with internal brake transistor GTR 7 (see "unit identification")
- 5) With units with integrated EMI filter the distance is less:
 up to max. 5m line length and 4kHz operating frequency = Limit Value B (EN 55011)
 up to max. 10m line length and 16kHz operating frequency = Limit Value A (EN 55022)
- 7) Rated operation means rated input voltage, rated output current, and rated carrier frequency.
- 8) 8 kHz only with a mounting plate > 55 in² and a 1.6 inch minimum distance to other components.

Technical Data

Technical Data 230V Class Continued

Inverter Size	15	16	17	18	19	20	21
Recommended Motor Power [hp]	15	20	25	30	40	50	60
Housing size	G	H	H	R	R	R	R
Input Ratings							
Supply voltage [V]	180...260 ±0 (230 V rated voltage)						
Supply voltage frequency [Hz]	50 / 60 +/- 2						
Input phases	3	3	3	3	3	3	3
Rated input current [A]	46	59	75	88	114	143	169
Recommended maximum input fuse [A]	50	60	80	100	100	125	200
Recommended wire gauge ³⁾ [awg]	8	6	4	3	3	1	2/O 3/O
Output Ratings							
Rated output power [kVA]	17	23	29	35	42	52	62
Rated motor power [kW]	11	15	18,5	22	30	37	45
Rated output current [A]	42	54	68	80	104	130	154
Peak current (30 seconds) ¹⁾ [A]	72	99	126	150	172	225	270
Over current fault (E.OC) trip level [A]	88	119	135	162	207	270	315
Overload curve (see annex)	1						
Output voltage [V]	3 x 0...V input (3 x 0...255V ²⁾)						
Output frequency [Hz]	Generally 0 to 1600Hz (limited by control board and carrier frequency)						
Rated switching frequency [kHz]	4	16	16	8	8	8	8
Maximum switching frequency [kHz]	4	16	16	16	8	8	8
Power loss at rated operation ⁷⁾ [W]	330	430	550	850	1020	1200	1700
Stall current at 4kHz [A]	36	48	66	84	100	115	180
Stall current at 8kHz [A]	-	48	66	84	100	115	180
Stall current at 16kHz [A]	-	48	66	50	-	-	-
Braking Circuit							
Min. braking resistance ⁴⁾ [Ohm]	13	5,6	5,6	4,7	4,7	3,3	2,5 2,5
Typ. braking resistance ⁴⁾ [Ohm]	16	13,6	8,8	5,6	5,6	4,7	3,9 3,0
Max. braking current [A]	29	70	70	88	88	133	160 160
Installation Information							
Max. shielded motor cable length ⁵⁾ [ft]	330			165			
Tightening torque for terminal strip [in lb]	11	22		53			
Environmental							
Max. heat sink temperature TOH [°C]	90°C / 194°F						
Storage temperature [°C]	-25...70 °C / -13... 158°F						
Operating temperature [°C]	-10...45 °C / 14... 113°F						
Housing design / protection	Chassis / IP20						
Relative humidity	max. 95% without condensation						
Approvals							
Tested in accordance with...	EN 61800-3 / UL508C						
Standards for emitted interference	EN 55011 Class B / EN 55022 Class A						
Standards for noise immunity	IEC 1000-4-2 / -3 / -4 / -5/ -6						
Climatic category	3K3 in accordance with EN 50178						

- 1) With the regulated systems F5-M as well as F5-S 5% must be subtracted as control reserve
- 3) The wire gauge is based on the maximum fuse rating, copper wire with minimum 75°C insulation rating, THHW or equivalent. If branch circuit protection is selected based on rated input current, the wire size could be reduced.
- 4) This data is only valid for units with internal brake transistor GTR 7 (see "unit identification")
- 5) The maximum cable length is the same for all carrier frequencies.
- 6) Contact KEBCO for this specifications.
- 7) Rated operation means, rated input voltage, rated output current, and rated carrier frequency.

2.2 Technical Data 460V Class

Inverter Size	05		07		09		10		12			13			14		
Recommended Motor Power [hp]	1/2		1		2		3		5			7,5			10		
Housing size	B	B	B	D	B	D	B	D	E	D	E	G	D	E	G		
Input Ratings																	
Supply voltage [V]	305...500 ±0 (460 V Nominal voltage ⁴⁾)																
Supply voltage frequency [Hz]	50 / 60 +/- 2																
Input phases	3	3	3	3	3	3	3	3	3	3	3	3	3	3	3		
Rated input current [A]	1,4	2,5	4,8	6,7	11	15	20	25	30	35	40	45	50	55	60		
Recommended maximum input fuse [A]	15	15	15	15	20	20	25	25	30	30	35	35	40	40	45		
Recommended wire gauge ¹⁾ [awg]	14	14	14	14	14	14	14	14	12	12	12	12	12	12	10		
Output Ratings																	
Rated output power [kVA]	0,9	1,8	2,8	4,0	6,6	8,3	11	14	17	21,6	27,7	33,8	40	48	57		
Rated motor power [kW]	0,37	0,75	1,5	2,2	4,0	5,5	7,5	9,5	12	15	18	22,5	28	34	40		
Rated output current [A]	1,0	1,8	3,4	4,8	7,6	11	14	17	21,6	27,7	33,8	40	48	57	66		
Peak current (30 seconds) ²⁾ [A]	2,3	4,7	7,4	10,4	17	21,6	27,7	33,8	40	48	57	66	75	84	93		
Over current fault (E.OC) trip level [A]	2,8	5,6	8,9	12,5	21	25,9	31,6	38,3	46	55,6	67,6	81	97,2	116,4	138,6		
Overload curve (see annex)	1																
Output voltage [V]	3 x 0...V Line																
Output frequency [Hz]	Generally 1600Hz however it is limited by the switching frequency																
Rated switching frequency [kHz]	16	16	8	8	8	16	4	8	16	4	8	16	2	8	16		
Maximum switching frequency [kHz]	16	16	16	16	16	16	4	16	16	16	16	16	4	16	16		
Power loss at rated operation ³⁾ [W]	60	90	80	105	120	170	150	185	300	185	250	200	185	320	260		
Stall current at 4kHz [A]	1,3	2,6	4,1	4,1	5,8	5,8	7,6	9,5	9,5	12	12	12	14	16,5	16,5		
Stall current at 8kHz [A]	1,3	2,6	4,1	4,1	5,8	5,8	-	9,5	9,5	9,5	12	12	-	16,5	16,5		
Stall current at 16kHz [A]	1,3	2,6	3,5	3,5	4,9	5,8	-	5,8	9,5	5,8	12	12	-	10	12		
Braking Circuit																	
Min. braking resistance ⁴⁾ [Ohm]	390	120	120	82	82	56	39	50	39	39	39	39	39	39	39		
Typ. braking resistance ⁴⁾ [Ohm]	390	390	270	270	150	100	82	82	82	82	82	82	82	82	82		
Max. braking current [A]	2.2	7.5	7.5	10	10	15	21	15	21	15	21	15	21	15	21		
Installation Information																	
Max. shielded motor cable length at 4 kHz ⁵⁾ [m]	30	30	330	330	330	165	330	300	300	300	300	300	300	300	300		
Max. shielded motor cable length at 8 kHz ⁵⁾ [m]	25	25	100	165	330	-	330	300	300	300	300	300	-	330	330		
Max. shielded motor cable length at 16kHz ⁵⁾ [m]	15	20	100	100	65	-	330	300	300	300	300	300	-	330	330		
Tightening torque for terminal strip [in lb]	4.5										4.5	4.5	11	4.5	4.5	11	
Environmental																	
Max. heat sink temperature TOH [°C]	90°C / 194°F																
Storage temperature [°C]	-25...70 °C / -13...158°F																
Operating temperature [°C]	-10...45 °C / 14...113°F																
Housing design / protection	Chassis / IP20																
Relative humidity	max. 95% without condensation																
Approvals																	
Tested in accordance with...	EN 61800-3 / UL508C																
Standards for emitted interference	EN 55011 Class B / EN 55022 Class A																
Standards for noise immunity	IEC 1000-4-2 / -3 / -4 / -5/ -6																
Climatic category	3K3 in accordance with EN 50178																

- 1) The wire gauge is based on the maximum fuse rating, copper wire with minimum 75°C insulation rating, THHW or equivalent. If branch circuit protection is selected based on rated input current, the wire size could be reduced.
- 2) With the regulated systems F5-M as well as F5-S 5% must be subtracted as control reserve
- 3) Rated operation means, rated input voltage, rated output current, and rated carrier frequency.
- 4) This data is only valid for units with internal brake transistor GTR 7 (see "unit identification")
- 5) With units with integrated EMI filter the distance is less:
 up to max. 5m line length and 4kHz operating frequency = Limit Value B (EN 55011)
 up to max. 10m line length and 16kHz operating frequency = Limit Value A (EN 55022)

Technical Data

Technical Data 460V Class continued

Inverter Size	15			16		17		18		19	
Recommended Motor Power [hp]	15			20		25		30		40	
Housing size	E	G	H	G	H	G	H	H	R	H	R
Input Ratings											
Supply voltage [V]	305...500 ±0 (460 V Nominal voltage)										
Supply voltage frequency [Hz]	50 / 60 +/- 2										
Input phases	3										
Rated input current [A]	27			35		44		52		57	
Recommended maximum input fuse [A]	35			40		60		60		70	
Recommended wire gauge ¹⁾ [awg]	10			8		6		6		4	
Output Ratings											
Rated output power [kVA]	17			23		29		35		42	
Rated motor power [kW]	11			15		18,5		22		30	
Rated output current [A]	21			27		34		40		52	
Peak current (30 seconds) ²⁾ [A]	36			49,5		63		75		90	
Over current fault (E.OC) trip level [A]	43,2			59,4		75,6		90		108	
Overload curve (see annex)	1										
Output voltage [V]	3 x 0...Vsupply										
Output frequency [Hz]	Generally 0 to 1600Hz (limited by control board and carrier frequency)										
Rated switching frequency [kHz]	4	8	16	8	16	4	8	8	16	4	8
Maximum switching frequency [kHz]	16	16	16	16	16	16	16	16	16	16	16
Power loss at rated operation ³⁾ [W]	350	290	360	310	490	360	470	610	850	540	750
Stall current at 4kHz [A]	24	24	24	33	33	42	42	50	50	60	60
Stall current at 8kHz [A]	16	19	24	21.5	33	29,4	30	45	50	39	60
Stall current at 16kHz [A]	10	8.5	15	9.7	20	21	13.5	20	40	18	27
Braking Circuit											
Min. braking resistance ⁴⁾ [Ohm]	39	39	22	25	22	25	22	13	9	13	9
Typ. braking resistance ⁴⁾ [Ohm]	56			39		28		22		16	
Max. braking current [A]	21	21	37	30	37	30	37	63	88	63	88
Installation Information											
Max. shielded motor cable length ⁵⁾ [ft]	330										
Tightening torque for terminal strip [in lb]	11		22	11	22	11	22	53	22	53	
Environmental											
Max. heat sink temperature TOH [°C]	90°C / 194°F										
Storage temperature [°C]	-25...70 °C / -13...158°F										
Operating temperature [°C]	-10...45 °C / 14...113°F										
Housing design / protection	Chassis / IP20										
Relative humidity	max. 95% without condensation										
Approvals											
Tested in accordance with...	EN 61800-3 /UL508C										
Standards for emitted interference	EN 55011 Class B / EN 55022 Class A										
Standards for noise immunity	IEC 1000-4-2 / -3 / -4 / -5/ -6										
Climatic category	3K3 in accordance with EN 50178										

- 1) The wire gauge is based on the maximum fuse rating, copper wire with minimum 75°C insulation rating, THHW or equivalent. If branch circuit protection is selected based on rated input current, the wire size could be reduced.
- 2) With the regulated systems F5-M as well as F5-S 5% must be subtracted as control reserve
- 3) Rated operation means, rated input voltage, rated output current, and rated carrier frequency.
- 4) This data is only valid for units with internal brake transistor GTR 7 (see "unit identification")
- 5) The maximum cable length is the same for all carrier frequencies.

Technical Data 460V Class continued

Inverter Size	20	21	22	23	24
Recommended Motor Power [hp]	50	60	75	100	125
Housing size	R	R	R	R	U
Input Ratings					
Supply voltage [V]	305...500 ±0 (460 V Nominal voltage)				
Supply voltage frequency [Hz]	50 / 60 +/- 2				
Input phases	3	3	3	3	3
Rated input current [A]	72	85	106	136	172
Recommended maximum input fuse [A]	80	100	125	175	200
Recommended wire gauge ¹⁾ [awg]	4	3	1	2/O	3/O
Output Ratings					
Rated output power [kVA]	52	62	80	104	125
Rated motor power [kW]	37	45	55	75	90
Rated output current [A]	65	77	96	124	156
Peak current (30 seconds) ²⁾ [A]	112	135	172	225	270
Over current fault (E.O.C) trip level [A]	135	162	207	270	324
Overload curve (see annex)	1				
Output voltage [V]	3 x 0...Vsupply				
Output frequency [Hz]	Generally 0 to 1600Hz (limited by control board and carrier frequency)				
Rated switching frequency [kHz]	8	4	8	4	8
Maximum switching frequency [kHz]	16	16	16	16	16
Power loss at rated operation ³⁾ [W]	900	1000	1100	1200	1500
Stall current at 4kHz [A]	75	90	90	115	115
Stall current at 8kHz [A]	75	63	90	80	115
Stall current at 16kHz [A]	34	45	54	46	51
Braking Circuit					
Min. braking resistance ⁴⁾ [Ohm]	9	9	9	6	5
Typ. braking resistance ⁴⁾ [Ohm]	13	11	9	6	6
Max. braking current [A]	88	88	88	133	160
Installation Information					
Max. shielded motor cable length ⁵⁾ [ft]	165				
Tightening torque for terminal strip [in lb]	53		133		
Environmental					
Max. heat sink temperature TOH [°C]	90°C / 194°F				
Storage temperature [°C]	-25...70 °C / -13...158°F				
Operating temperature [°C]	-10...45 °C / 14...113°F				
Housing design / protection	Chassis / IP20				
Relative humidity	max. 95% without condensation				
Approvals					
Tested in accordance with...	EN 61800-3 /UL508C				
Standards for emitted interference	EN 55011 Class B / EN 55022 Class A				
Standards for noise immunity	IEC 1000-4-2 / -3 / -4 / -5/ -6				
Climatic category	3K3 in accordance with EN 50178				

- 1) The wire gauge is based on the maximum fuse rating, copper wire with minimum 75°C insulation rating, THHW or equivalent. If branch circuit protection is selected based on rated input current, the wire size could be reduced.
- 2) With the regulated systems F5-M as well as F5-S 5% must be subtracted as control reserve
- 3) Rated operation means, rated input voltage, rated output current, and rated carrier frequency.
- 4) This data is only valid for units with internal brake transistor GTR 7 (see "unit identification")
- 5) The maximum cable length is the same for all carrier frequencies.

Technical Data

Inverter Size	25	26	27
Recommended Motor Power [hp]	150	175	200
Housing size	U	U	U
Input Ratings			
Supply voltage [V]	305...500 ±0 (460 V Nominal voltage)		
Supply voltage frequency [Hz]	50 / 60 +/- 2		
Input phases	3	3	3
Rated input current [A]	198	231	264
Recommended maximum input fuse [A]	250	310	450
Recommended wire gauge ¹⁾ kcmil	250	350	150
Output Ratings			
Rated output power [kVA]	145	173	208
Rated motor power [kW]	110	132	160
Rated output current [A]	180	210	240
Peak current (30 seconds) ²⁾ [A]	263	313	375
Over current fault (E_OC) trip level [A]	315	375	450
Overload curve (see annex)	2		
Output voltage [V]	3 x 0...Vsupply		
Output frequency [Hz]	Generally 800Hz (but it is limited by the control card)		
Rated switching frequency [kHz]	4	4	2
Maximum switching frequency [kHz]	8	8	8
Power loss at rated operation ³⁾ [W]	2300	2800	3100
Stall current at 4kHz [A]	210	250	240
Stall current at 8kHz [A]	168	162	180
Braking Circuit			
Min. braking resistance ⁴⁾ [Ohm]	2,5	2,5	2,5
Typ. braking resistance ⁴⁾ [Ohm]	4,3	3,8	3,3
Max. braking current [A]	200	200	200
Installation Information			
Max. shielded motor cable length ⁵⁾ [ft]	165		
Tightening torque for terminal strip	220		
Environmental			
Max. heat sink temperature TOH [°C]	90°C / 194°F		
Storage temperature [°C]	-25...70 °C / -13...158°F		
Operating temperature [°C]	-10...45 °C / 14...113°F		
Housing design / protection	Chassis / IP20		
Relative humidity	max. 95% without condensation		
Approvals			
Tested in accordance with...	EN 61800-3 /UL508C		
Standards for emitted interference	EN 55011 Class B / EN 55022 Class A		
Standards for noise immunity	IEC 1000-4-2 / -3 / -4 / -5/ -6		
Climatic category	3K3 in accordance with EN 50178		

- 1) The wire gauge is based on the maximum fuse rating, copper wire with minimum 75°C insulation rating, THHW or equivalent. If branch circuit protection is selected based on rated input current, the wire size could be reduced.
- 2) With the regulated systems F5-M as well as F5-S 5% must be subtracted as control reserve
- 3) Rated operation means, rated input voltage, rated output current, and rated carrier frequency.
- 4) This data is only valid for units with internal brake transistor GTR 7 (see "unit identification")
- 5) The maximum cable length is the same for all carrier frequencies.

2.3 Dimensions and Weight

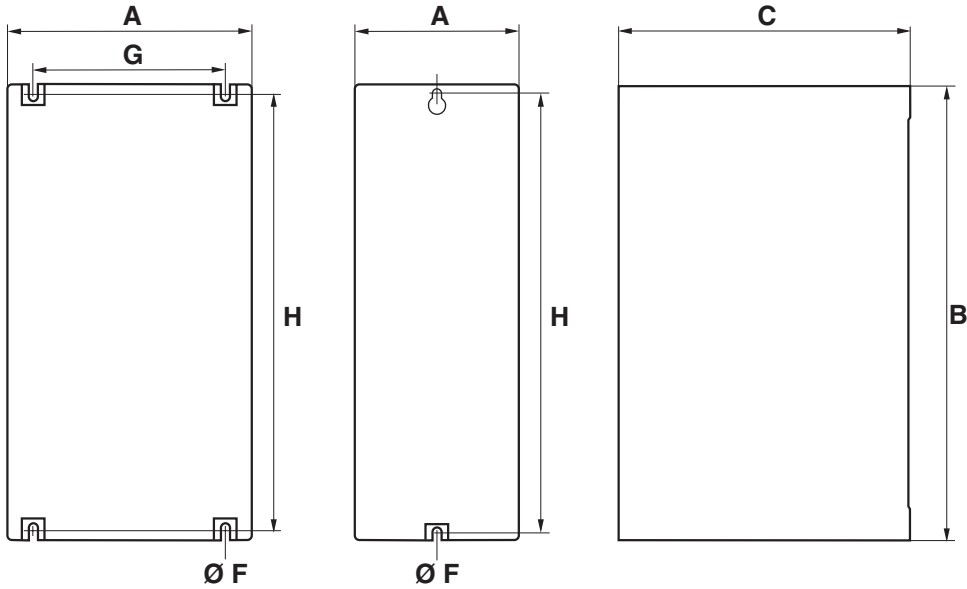

Housing	A (width)	B (height)	C (with Operator) (depth)	F	G	H	Weight
A	3.00	7.52 *	5.67 (6.22)	0.197	–	6.89	2.0 lbs 2.4 lbs w/filter
B	3.54	8.66 *	6.30 (6.85)	0.197	–	8.27	4.4 lbs
D	3.54	9.84 *	7.13 (7.68)	0.197	–	9.45	6.6 lbs
E	5.12	11.4 *	8.19 (8.74)	0.276	–	10.8	11 lbs
G	6.69	13.4	10.0	0.276	5.91	13.0	22 lbs
H	11.7	13.4	10.0	0.276	9.84	13.0	31 lbs
R	13.4	20.5	14.0	0.394	11.8	19.5	55 lbs
U	13.4	31.5	14.0	0.394	11.8	30.5	165 lbs

Dimensions in inches

*) This dimension will be greater when using the shielding plate which comes with the EMI filter.

2.4 Survey of Power Circuit Terminals

Housing size A

1 phase

Motor side

Supply side

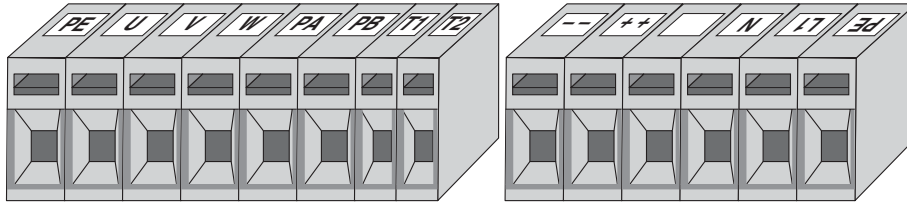

U, V, W Motor connection
 PA, PB Connection for braking resistor
 T1, T2 Connection for temperature sensor
 PE Connection for earth ground

L1, N 1 phase supply connection
 (L2) (connect two hot leads e.g. L1,L2 from a 208V 3 phase system)
 ++, -- DC supply connection

Housing size B,D,E

1 phase or 3 phase



Note always verify input voltage with name plate for proper connection 230V or 460V

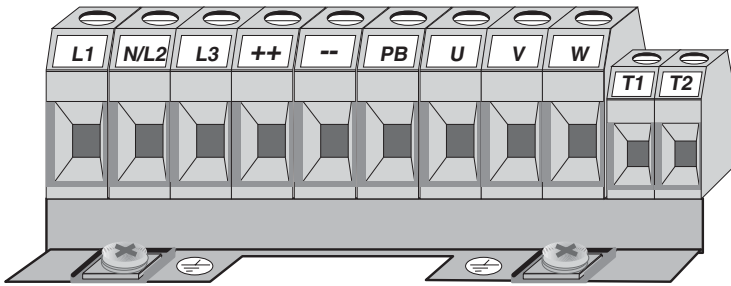

Terminal Tightening Torque: 4.5 inlb

L1, N/L2 1 phase supply voltage only 230V units.
 (Connect two hot leads e.g. L1,L2 from a 208V 3phase system)
 L1, L2, L3 3 phase supply voltage
 ++, -- Connection for DC supply
 ++, PB Connection for braking resistor
 U, V, W Motor connection
 T1, T2 Connection for temperature sensor
 ⊕ Connection for earth ground

Housing size G

3 phase



Note always verify input voltage with name plate for proper connection 230V or 460V

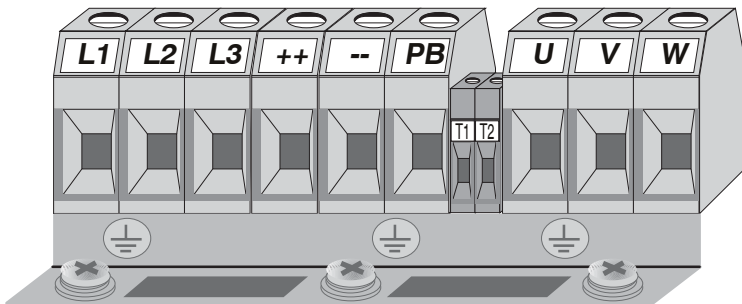

Terminal Tightening Torque: 11 inlb

L1, L2, L3 3 phase supply voltage
 ++, -- Connection for DC supply
 ++, PB Connection for braking resistor
 T1, T2 Connection for temperature sensor
 U, V, W Motor connection
 ⊕ Connection for earth ground

Housing size H



Note always verify input voltage with name plate for proper connection 230V or 460V

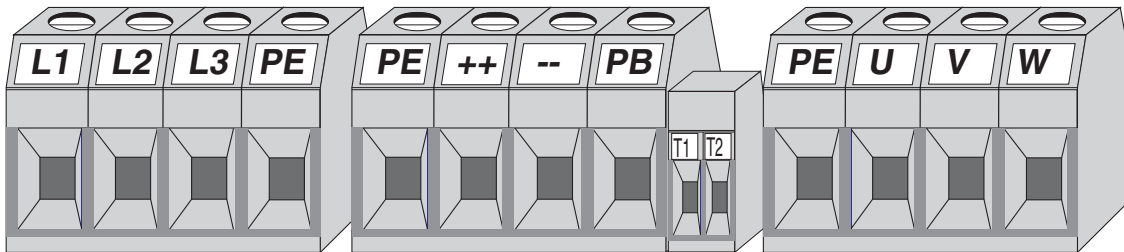

L1, L2, L3
++ , --
++ , PB

3 phase supply voltage
 DC supply connection
 Connection for braking resistor

T1, T2
U, V, W
PE

Connection for temperature sensor
 Motor connection
 Connection for earth ground

Terminal Tightening Torque: 22 inlb

Housing size R and U



Note always verify input voltage with name plate for proper connection

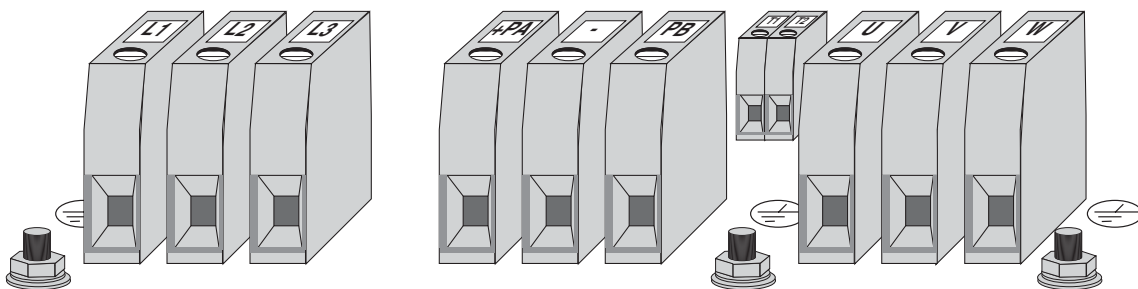

L1, L2, L3
++ , --
++ , PB

3 phase supply voltage
 DC supply connection
 Connection for braking resistor

T1, T2
U, V, W

Connection for temperature sensor
 Motor connection



Connection for earth ground

Terminal Tightening Torque: R housings 53 inlb
 U housings size 23/24 130inlb
 U housings sizes > 24 220 inlb

Connection of Power Circuit

2.5 Connection of Power Circuit

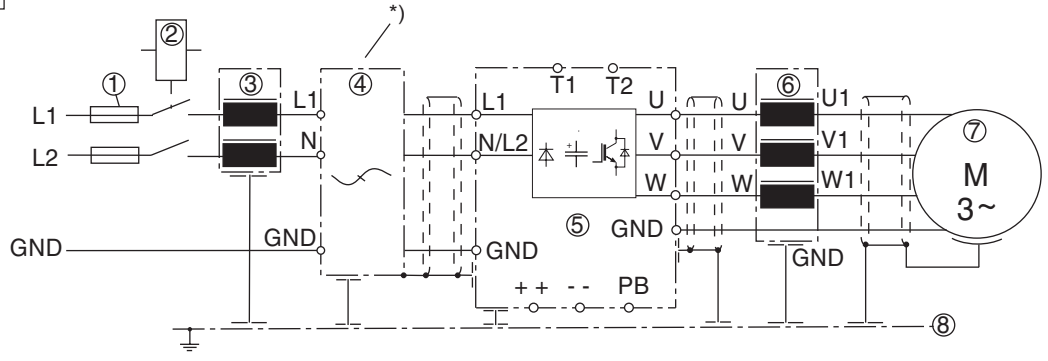
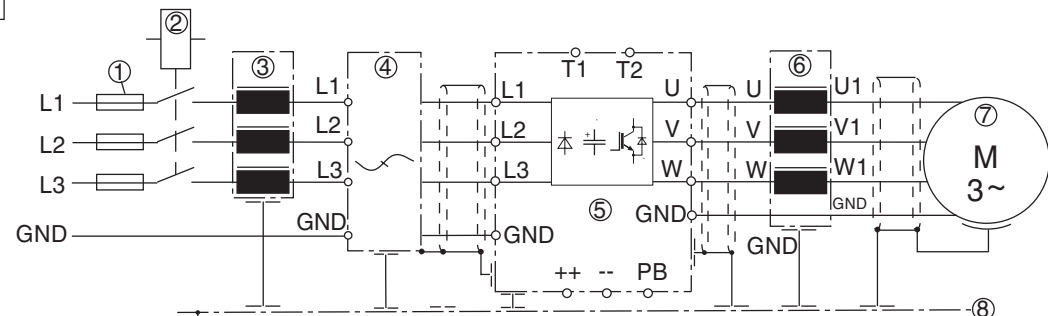
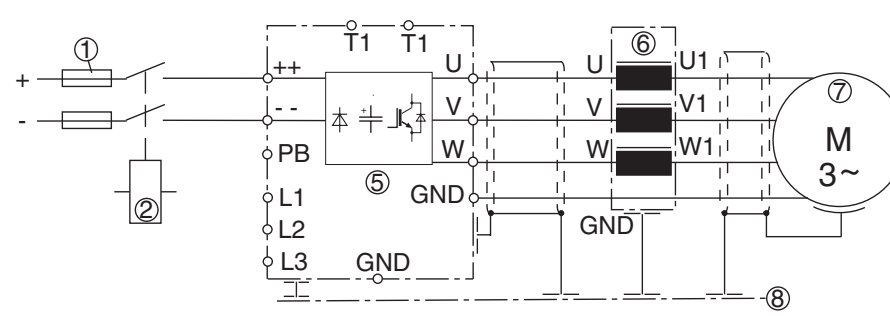
If the supply voltage is connected to the motor terminals, the unit will be destroyed!	Pay attention to the supply voltage 230/460V and the correct polarity of the motor!								
<p>1-phase connection</p> <p>Use type LPJ fuses for branch circuit protection.</p>  <p>The diagram shows a single-phase AC supply (L1, L2) entering through a disconnect switch (2) and a line choke (3). It passes through an interference suppression filter (4) to a COMBIVERT F5 inverter (5). The inverter's output (U, V, W) goes through a motor choke (6) to a 3-phase motor (7). Grounding (GND) is shown at multiple points. A sub-panel (8) is located in the control cabinet.</p> <p>* For units with integrated radio interference suppression (see "Part Number") the external radio interference suppression filter is omitted.</p>									
<p>3-phase connection</p> <p>Use type LPJ fuses for branch circuit protection.</p>  <p>The diagram shows a three-phase AC supply (L1, L2, L3) entering through a disconnect switch (2) and three line chokes (3). It passes through an interference suppression filter (4) to a COMBIVERT F5 inverter (5). The inverter's output (U, V, W) goes through a motor choke (6) to a 3-phase motor (7). Grounding (GND) is shown at multiple points. A sub-panel (8) is located in the control cabinet.</p>									
<p>DC power supply</p> <p>250...370 VDC (230V-class) 420...720V DC (460V-class)</p> <p>Use type FWP fuses for branch circuit protection.</p>  <p>The diagram shows a DC supply (+, -) entering through a disconnect switch (2) and two FWP fuses (1). It passes through a COMBIVERT F5 inverter (5) configured for DC input. The inverter's output (U, V, W) goes through a motor choke (6) to a 3-phase motor (7). Grounding (GND) is shown at multiple points. A sub-panel (8) is located in the control cabinet.</p>									
<table border="0"> <tr> <td data-bbox="95 1724 351 1769">① Supply fuse</td> <td data-bbox="782 1724 1085 1769">⑤ COMBIVERT F5</td> </tr> <tr> <td data-bbox="95 1780 622 1825">② Disconnect switch or contactor</td> <td data-bbox="782 1780 1244 1859">⑥ Motor choke or output filter (do not use with F5M or F5S)</td> </tr> <tr> <td data-bbox="95 1870 335 1915">③ Line choke</td> <td data-bbox="782 1870 941 1915">⑦ Motor</td> </tr> <tr> <td data-bbox="95 1915 606 1960">④ Interference suppression filter</td> <td data-bbox="782 1915 1260 1960">⑧ Sub panel in control cabinet</td> </tr> </table>		① Supply fuse	⑤ COMBIVERT F5	② Disconnect switch or contactor	⑥ Motor choke or output filter (do not use with F5M or F5S)	③ Line choke	⑦ Motor	④ Interference suppression filter	⑧ Sub panel in control cabinet
① Supply fuse	⑤ COMBIVERT F5								
② Disconnect switch or contactor	⑥ Motor choke or output filter (do not use with F5M or F5S)								
③ Line choke	⑦ Motor								
④ Interference suppression filter	⑧ Sub panel in control cabinet								

External motor temperature sensor (for all units)

On F5 B/G units it is necessary to activate the function through parameter CP.28.

Don't install temperature sensor wires with other control wires.

Must use double shield when running temperature sensor wires with motor wires

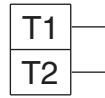

F5-M/S:
Bridge, when no sensor is connected

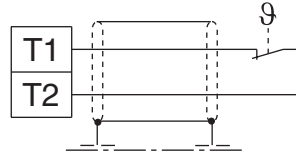

Thermal switch
(NC-contact)

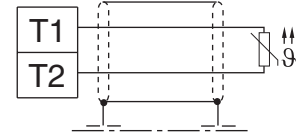

Temperature sensor (PTC)
1650Ω...4kΩ tripping resistance
750Ω...1650Ω reset resistance

Braking resistor

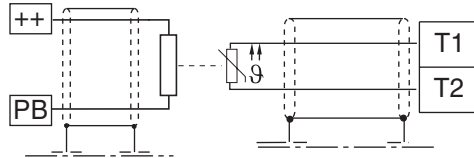

Optional Connection
connect only when resistor has valid temperature sensor, e.g. back mount resistors

Braking resistor with line side over temperature cutoff



This is the only way to turn off voltage to the resistor in the event of failure of the internal braking transistor of the inverter.

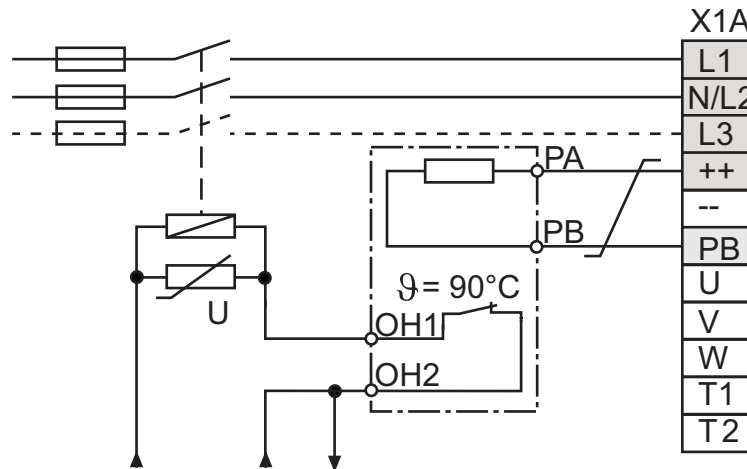

24VDC or 120VAC contactor control voltage

Note: a NC thermal switch not PTC device on the resistor is required.

Braking module

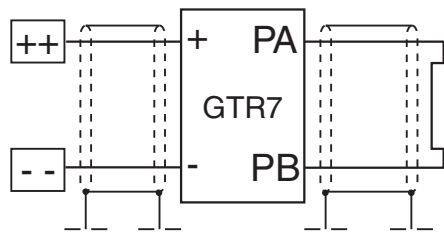

3. Accessories

3.1 Braking Resistor

The COMBIVERT F5 inverter can be equipped with an external braking resistor for limited 4 quadrant operation. The energy the motor regens into the inverter during deceleration is dissipated through the internal braking transistor to the braking resistor.



The braking resistor heats up during braking. If it is installed inside a control cabinet, sufficient interior cooling must be provided! The resistor should be mounted above and a minimum of 9 inches away from the inverter or in a separate enclosure!

3.1.1 Selection of the Braking Resistor

Different braking resistors are available from KEBCO. They are selected according to their application requirements. The selection formulas and technical data of the resistors are listed on the following pages. The procedure for selecting a braking resistor is outlined below.

1. Establish desired braking time.
2. Calculate braking time without braking resistor (t_{Bmin}).
3. If the desired braking time is shorter than the calculated braking time, it will be necessary to use a braking resistor. ($t_B < t_{Bmin}$)
4. Calculate braking torque (T_B) taking the load torque (T_L) into account. T_L is a positive value for friction and windage and negative for overhauling loads.
5. Calculate peak braking power (P_B). This must always be calculated for the "worst case" (n_{max} to standstill).
6. Selection of the braking resistors:
 - a) The resistor should be selected so that $P_R > P_B$.
 - b) P_N is to be selected according to the duty cycle factor (d.c.f.).

The braking resistors may only be used for the specified value. The maximum ON period of the braking resistor may not be exceeded.

6 % d.c.f. =	maximum braking time 8 s
25 % d.c.f. =	maximum braking time 30 s
40 % d.c.f. =	maximum braking time 48 s

Longer ON periods require specially-designed braking resistors. Take into account the current through the braking transistor.

7. Check whether the desired braking time is attained with the selected braking resistor (t_{Bmin}).



Note: Consider the capacity of the braking resistor and motor. The braking torque may not exceed the rated torque of the motor by more than 1.5 times. To realize maximum possible braking torque, the frequency inverter must be sized for the increased motor current.

Braking time

The braking time is adjusted in the frequency inverter through the deceleration parameters. If the selected deceleration time is too short, either the peak inverter current level or the maximum DC bus voltage will be exceeded. The error message **E.OC** or **E.OP** will result. The following formulas can be used to determine an allowable braking time.

Formulas

1. Braking time without braking resistor

$$t_{Bmin} = \frac{(J_M + J_L) \cdot (n_1 - n_2)}{307 \cdot (K \cdot T_N + T_L)}$$

Valid range: $n_1 > n_N$
(field weakening)

2. Braking torque (required)

$$T_B = \frac{(J_M + J_L) \cdot (n_1 - n_2)}{307 \cdot t_B} - T_L$$

Conditions: $T_B - 1.5 \cdot T_N$
 $f < 1.4 \times$ rated frequency of motor

3. Peak braking power

$$P_B = \frac{T_B \cdot n_1}{7.04}$$

Conditions: $P_B < P_R$

4. Braking time with braking resistor

$$t_{Bmin} = \frac{(J_M + J_L) \cdot (n_1 - n_2)}{307 \cdot (K \cdot T_N + T_L + \frac{P_R \cdot 7.04}{(n_1 - n_2)})}$$

Valid range: $n_1 > n_N$
Conditions: $\frac{P_R \cdot 9.55}{(n_1 - n_2)} - T_N \cdot (1.5 - K)$
 $f < 1.4 \times$ rated frequency of motor
 $P_B < P_R$

On period d.c.f.

ON period d.c.f for cycle time $t_z < 120$ s

$$\text{d.c.f} = \frac{t_B}{t_z} \cdot 100 \%$$

ON period d.c.f for cycle time $t_z > 120$ s

$$\text{d.c.f} = \frac{t_B}{120 \text{ s}} \cdot 100 \%$$

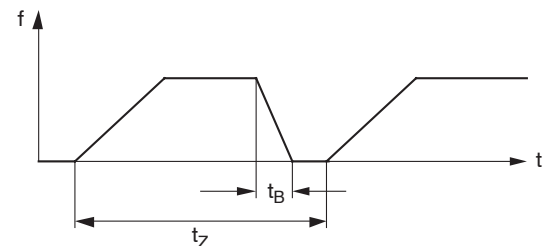

Definitions

K = 0.25 for motors	up to 2 hp
0.20 for motors	3 to 5 hp
0.15 for motors	7.5 to 15 hp
0.08 for motors	20 to 60 hp
0.05 for motors	75 to 400 hp

J_M	= Moment of inertia of the motor	[lb ft ²]	T_B	= Braking torque (required)	[ft lbs]
J_L	= Moment of inertia of the load	[lb ft ²]	T_L	= Load torque	[ft lbs]
n_1	= Motor speed before deceleration	[rpm]	t_B	= Braking time (required)	[s]
n_2	= Motor speed after deceleration (Stand still = 0 rpm)	[rpm]	t_{Bmin}	= Minimum braking time	[s]
n_N	= Motor rated speed	[rpm]	t_z	= Cycle time	[s]
T_N	= Motor rated torque	[ft lbs]	P_B	= Peak braking power	[W]
			P_R	= Peak power dissipation of the resistor	[W]

Accessories

3.1.2 Panel Mount Brake Resistors

Technical data braking resistor

Part number	R _B [OHM]	P _{Rated} [kW]	COMBIVERT	Nominal power ¹⁾ [W]		
				6 s	25 s	40 s
230 V - Class						
07.BR.100-1180	180	44	05, 07	800	300	180
09.BR.100-1100	100	82	07, 09	1500	500	300
10.BR.100-1683	68	120	07, 09, 10, 13(E)	2200	800	500
12.BR.100-1333	33	250	10, 13(G)	4400	1300	750
13.BR.100-1273	27	300	13(G), 14	5400	1500	900
14.BR.100-1203	20	450	13(G), 14	7300	1800	1100
15.BR.110-1133	13	630	14, 15	10000	3200	1800
16.BR.110-1103	10	850	15, 16	14000	3600	2200
17.BR.110-1073	7	1100	15, 16, 17	21000	5400	3100
18.BR.110-1053*	5	1900	17, 18	28000	7200	4400
19.BR.110-1356*	3.5	2200	19,20	42000	10800	6200
20.BR.110-1256*	2.5	3800	20,21	56000	14400	8800
*consult KEBCO for exact specifications						
400 V - Class						
07.BR.100-6620	620	56	05, 07	900	300	180
09.BR.100-6390	390	90	07, 09	1500	500	300
10.BR.100-6270	270	130	07, 09, 10	2100	800	500
12.BR.100-6150	150	230	12	3700	1300	750
13.BR.100-6110	110	350	12, 13	5000	1500	900
14.BR.100-6853	85	410	12, 13, 14	6500	1800	1100
15.BR.110-6563	56	620	12(E), 13(E,G), 14, 15	10000	3200	1800
16.BR.110-6423	42	820	13(G), 14(G), 15, 16	13500	3600	2200
17.BR.110-6303	30	1200	15(H), 16, 17	18500	5400	3100
18.BR.226-6203	20	1700	17(R), 18, 19	27500	7500	4500
19.BR.226-6153	15	2300	17(R), 18, 19, 20	37000	10000	6000
20.BR.226-6123	12	2900	18(R), 19(R), 20, 21	46000	12500	7500
21.BR.226-6103	10	3000	18(R), 19(R), 20, 21, 22	55000	15000	9000
22.BR.226-6866	8,6	4000	21(L), 22(L), 23	64000	17500	10000
23.BR.226-6676	6,7	5200	22(L), 23, 24(U)	82000	22000	12500
24.BR.226-6506	5	6900	23(U), 24(U), 25(U)	110000	30000	18000
25.BR.226-6436	4,3	8100	24(U), 25(U), 26(U), 27(U)	130000	35000	20000
26.BR.226-6386	3,8	9200	25, 26, 27(U)	145000	40000	22500
27.BR.226-6336	3,3	10000	25, 26, 27(U)	170000	45000	25000
28.BR.226-6226	2,2	15000	28(W), 29(W), 30(W)	250000	67000	37000
29.BR.226-6176	1,7	20000	28(W), 29(W), 30(W)	325000	90000	50000
30.BR.226-6136	1,3	26000	28(W), 29(W), 30(W)	425000	112000	62000

1) Permissible power dissipation of the resistor is dependent on the duty cycle factor; braking time divided by 120 seconds. The calculated peak braking time must be ≤ the load of the resistor.

	<table border="1"> <thead> <tr> <th>Part number</th> <th>A</th> <th>B</th> <th>C</th> <th>D</th> <th>E</th> <th>F</th> <th>L</th> </tr> </thead> <tbody> <tr> <td>07.BR.100-xxxx</td> <td>0.95</td> <td>6.5</td> <td>1.57</td> <td>-</td> <td>5.67</td> <td>0.20</td> <td>39.0</td> </tr> <tr> <td>09.BR.100-xxxx</td> <td>0.95</td> <td>9.5</td> <td>1.57</td> <td>-</td> <td>8.74</td> <td>0.20</td> <td>39.0</td> </tr> <tr> <td>10.BR.100-xxxx</td> <td>0.95</td> <td>11.8</td> <td>1.57</td> <td>-</td> <td>11.22</td> <td>0.20</td> <td>39.0</td> </tr> <tr> <td>12.BR.100-xxxx</td> <td>1.0</td> <td>11.8</td> <td>3.15</td> <td>-</td> <td>11.22</td> <td>0.20</td> <td>39.0</td> </tr> <tr> <td>13.BR.100-xxxx</td> <td>1.0</td> <td>15.75</td> <td>3.15</td> <td>-</td> <td>15.16</td> <td>0.20</td> <td>39.0</td> </tr> <tr> <td>14.BR.100-xxxx</td> <td>1.0</td> <td>15.75</td> <td>3.15</td> <td>-</td> <td>15.16</td> <td>0.20</td> <td>39.0</td> </tr> <tr> <td>15.BR.110-xxxx</td> <td>2.48</td> <td>14.6</td> <td>3.78</td> <td>-</td> <td>13.98</td> <td>0.20</td> <td>39.0</td> </tr> <tr> <td>16.BR.110-xxxx</td> <td>2.48</td> <td>18.5</td> <td>3.78</td> <td>-</td> <td>17.91</td> <td>0.20</td> <td>39.0</td> </tr> </tbody> </table> <p style="text-align: right;">Dimensions in inches</p>	Part number	A	B	C	D	E	F	L	07.BR.100-xxxx	0.95	6.5	1.57	-	5.67	0.20	39.0	09.BR.100-xxxx	0.95	9.5	1.57	-	8.74	0.20	39.0	10.BR.100-xxxx	0.95	11.8	1.57	-	11.22	0.20	39.0	12.BR.100-xxxx	1.0	11.8	3.15	-	11.22	0.20	39.0	13.BR.100-xxxx	1.0	15.75	3.15	-	15.16	0.20	39.0	14.BR.100-xxxx	1.0	15.75	3.15	-	15.16	0.20	39.0	15.BR.110-xxxx	2.48	14.6	3.78	-	13.98	0.20	39.0	16.BR.110-xxxx	2.48	18.5	3.78	-	17.91	0.20	39.0																																								
Part number	A	B	C	D	E	F	L																																																																																																										
07.BR.100-xxxx	0.95	6.5	1.57	-	5.67	0.20	39.0																																																																																																										
09.BR.100-xxxx	0.95	9.5	1.57	-	8.74	0.20	39.0																																																																																																										
10.BR.100-xxxx	0.95	11.8	1.57	-	11.22	0.20	39.0																																																																																																										
12.BR.100-xxxx	1.0	11.8	3.15	-	11.22	0.20	39.0																																																																																																										
13.BR.100-xxxx	1.0	15.75	3.15	-	15.16	0.20	39.0																																																																																																										
14.BR.100-xxxx	1.0	15.75	3.15	-	15.16	0.20	39.0																																																																																																										
15.BR.110-xxxx	2.48	14.6	3.78	-	13.98	0.20	39.0																																																																																																										
16.BR.110-xxxx	2.48	18.5	3.78	-	17.91	0.20	39.0																																																																																																										
	<table border="1"> <thead> <tr> <th>Part number</th> <th>A</th> <th>B</th> <th>C</th> <th>D</th> <th>E</th> <th>F</th> <th>L</th> </tr> </thead> <tbody> <tr> <td>17.BR.110-xxxx</td> <td>3.54</td> <td>18.5</td> <td>3.78</td> <td>1.97</td> <td>17.91</td> <td>0.20</td> <td>39.0</td> </tr> <tr> <td>18.BR.110-1103</td> <td colspan="7">= 2 x 16.BR.110-1103</td> </tr> <tr> <td>19.BR.110-xxxx</td> <td colspan="7">= 2 x 17.BR.110-1073</td> </tr> <tr> <td>20.BR.110-xxxx</td> <td colspan="7">= 4 x 16.BR.110-1103</td> </tr> </tbody> </table> <p style="text-align: right;">Dimensions in inches</p>	Part number	A	B	C	D	E	F	L	17.BR.110-xxxx	3.54	18.5	3.78	1.97	17.91	0.20	39.0	18.BR.110-1103	= 2 x 16.BR.110-1103							19.BR.110-xxxx	= 2 x 17.BR.110-1073							20.BR.110-xxxx	= 4 x 16.BR.110-1103																																																																														
Part number	A	B	C	D	E	F	L																																																																																																										
17.BR.110-xxxx	3.54	18.5	3.78	1.97	17.91	0.20	39.0																																																																																																										
18.BR.110-1103	= 2 x 16.BR.110-1103																																																																																																																
19.BR.110-xxxx	= 2 x 17.BR.110-1073																																																																																																																
20.BR.110-xxxx	= 4 x 16.BR.110-1103																																																																																																																
	<table border="1"> <thead> <tr> <th>Part number</th> <th>A</th> <th>B</th> <th>C</th> <th>D</th> <th>E</th> <th>F</th> <th>G</th> </tr> </thead> <tbody> <tr> <td>18.BR.226-6203</td> <td>10.5</td> <td>24.1</td> <td>4.57</td> <td>9.45</td> <td>20.71</td> <td>0.25x0.4</td> <td>6.93</td> </tr> <tr> <td>19.BR.226-6153</td> <td>10.5</td> <td>24.1</td> <td>4.57</td> <td>9.45</td> <td>20.71</td> <td>0.25x0.4</td> <td>6.93</td> </tr> <tr> <td>20.BR.226-6123</td> <td>10.5</td> <td>24.8</td> <td>8.7</td> <td>9.45</td> <td>20.71</td> <td>0.25x0.4</td> <td>6.93</td> </tr> <tr> <td>21.BR.226-6103</td> <td>10.5</td> <td>24.8</td> <td>8.7</td> <td>9.45</td> <td>20.71</td> <td>0.25x0.4</td> <td>6.93</td> </tr> <tr> <td>22.BR.226-6866</td> <td>10.5</td> <td>24.8</td> <td>10.7</td> <td>9.45</td> <td>20.71</td> <td>0.25x0.4</td> <td>6.93</td> </tr> <tr> <td>23.BR.226-6676</td> <td>10.5</td> <td>24.8</td> <td>10.7</td> <td>9.45</td> <td>20.71</td> <td>0.25x0.4</td> <td>6.93</td> </tr> <tr> <td>24.BR.226-6506</td> <td colspan="7">= 2 x 21.BR.226-6103</td> </tr> <tr> <td>25.BR.226-6436</td> <td colspan="7">= 2 x 22.BR.226-6866</td> </tr> <tr> <td>26.BR.226-6386</td> <td colspan="7">= 1 x 22.BR.226-6866 + 1 x 23.BR.226-6676</td> </tr> <tr> <td>27.BR.226-6336</td> <td colspan="7">= 2 x 23.BR.226-6676</td> </tr> <tr> <td>28.BR.226-6226</td> <td colspan="7">= 3 x 23.BR.226-6676</td> </tr> <tr> <td>29.BR.226-6176</td> <td colspan="7">= 4 x 23.BR.226-6676</td> </tr> <tr> <td>30.BR.226-6136</td> <td colspan="7">= 5 x 23.BR.226-6676</td> </tr> </tbody> </table> <p style="text-align: right;">Dimensions in inches</p>	Part number	A	B	C	D	E	F	G	18.BR.226-6203	10.5	24.1	4.57	9.45	20.71	0.25x0.4	6.93	19.BR.226-6153	10.5	24.1	4.57	9.45	20.71	0.25x0.4	6.93	20.BR.226-6123	10.5	24.8	8.7	9.45	20.71	0.25x0.4	6.93	21.BR.226-6103	10.5	24.8	8.7	9.45	20.71	0.25x0.4	6.93	22.BR.226-6866	10.5	24.8	10.7	9.45	20.71	0.25x0.4	6.93	23.BR.226-6676	10.5	24.8	10.7	9.45	20.71	0.25x0.4	6.93	24.BR.226-6506	= 2 x 21.BR.226-6103							25.BR.226-6436	= 2 x 22.BR.226-6866							26.BR.226-6386	= 1 x 22.BR.226-6866 + 1 x 23.BR.226-6676							27.BR.226-6336	= 2 x 23.BR.226-6676							28.BR.226-6226	= 3 x 23.BR.226-6676							29.BR.226-6176	= 4 x 23.BR.226-6676							30.BR.226-6136	= 5 x 23.BR.226-6676						
Part number	A	B	C	D	E	F	G																																																																																																										
18.BR.226-6203	10.5	24.1	4.57	9.45	20.71	0.25x0.4	6.93																																																																																																										
19.BR.226-6153	10.5	24.1	4.57	9.45	20.71	0.25x0.4	6.93																																																																																																										
20.BR.226-6123	10.5	24.8	8.7	9.45	20.71	0.25x0.4	6.93																																																																																																										
21.BR.226-6103	10.5	24.8	8.7	9.45	20.71	0.25x0.4	6.93																																																																																																										
22.BR.226-6866	10.5	24.8	10.7	9.45	20.71	0.25x0.4	6.93																																																																																																										
23.BR.226-6676	10.5	24.8	10.7	9.45	20.71	0.25x0.4	6.93																																																																																																										
24.BR.226-6506	= 2 x 21.BR.226-6103																																																																																																																
25.BR.226-6436	= 2 x 22.BR.226-6866																																																																																																																
26.BR.226-6386	= 1 x 22.BR.226-6866 + 1 x 23.BR.226-6676																																																																																																																
27.BR.226-6336	= 2 x 23.BR.226-6676																																																																																																																
28.BR.226-6226	= 3 x 23.BR.226-6676																																																																																																																
29.BR.226-6176	= 4 x 23.BR.226-6676																																																																																																																
30.BR.226-6136	= 5 x 23.BR.226-6676																																																																																																																



Risk of Fire!

In order to safe guard against overheating braking resistors, it is absolutely necessary to connect the thermal contact of the braking resistor to the inverter (See connection to T1/T2 terminals on page 25). Overheating can have the following causes:

- ramps are too short
- too many stops per minute
- under dimensioned braking resistor
- input voltage too high, i.e. > 525VAC
- defective braking transistor in the inverter



If the braking transistor in the inverter fails, then the only means of preventing the destruction of the resistor is by disconnecting the inverter from the line via a contactor. The contactor can be opened using the fault relay on the inverter.

3.1.3 Parallel Connection of Braking Resistors

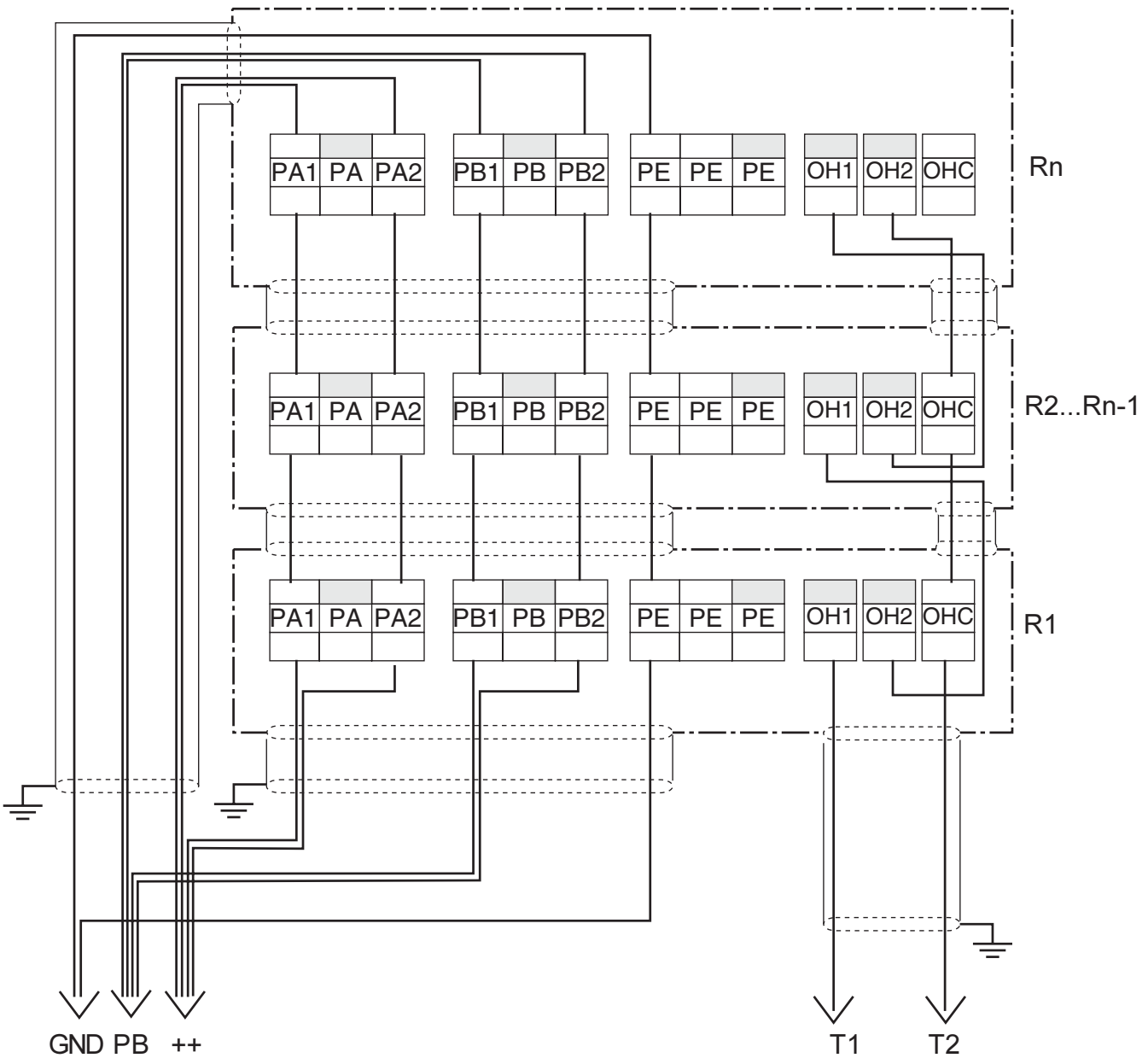
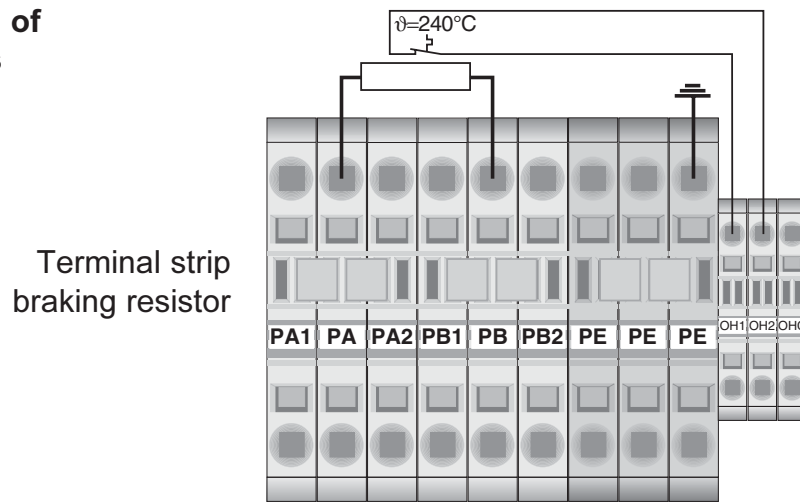

3.1.4 Back Mount Braking Resistor

The inverter mounted braking resistor is designed with space savings in mind. The resistor is mounted directly under the heatsink of the inverter. The heat generated flows vertically out the top of the unit. It should be used only in applications where the braking time is kept to a minimum. The resistor kit consists of:

- Braking resistor
- Temperature sensor
- Mounting hardware

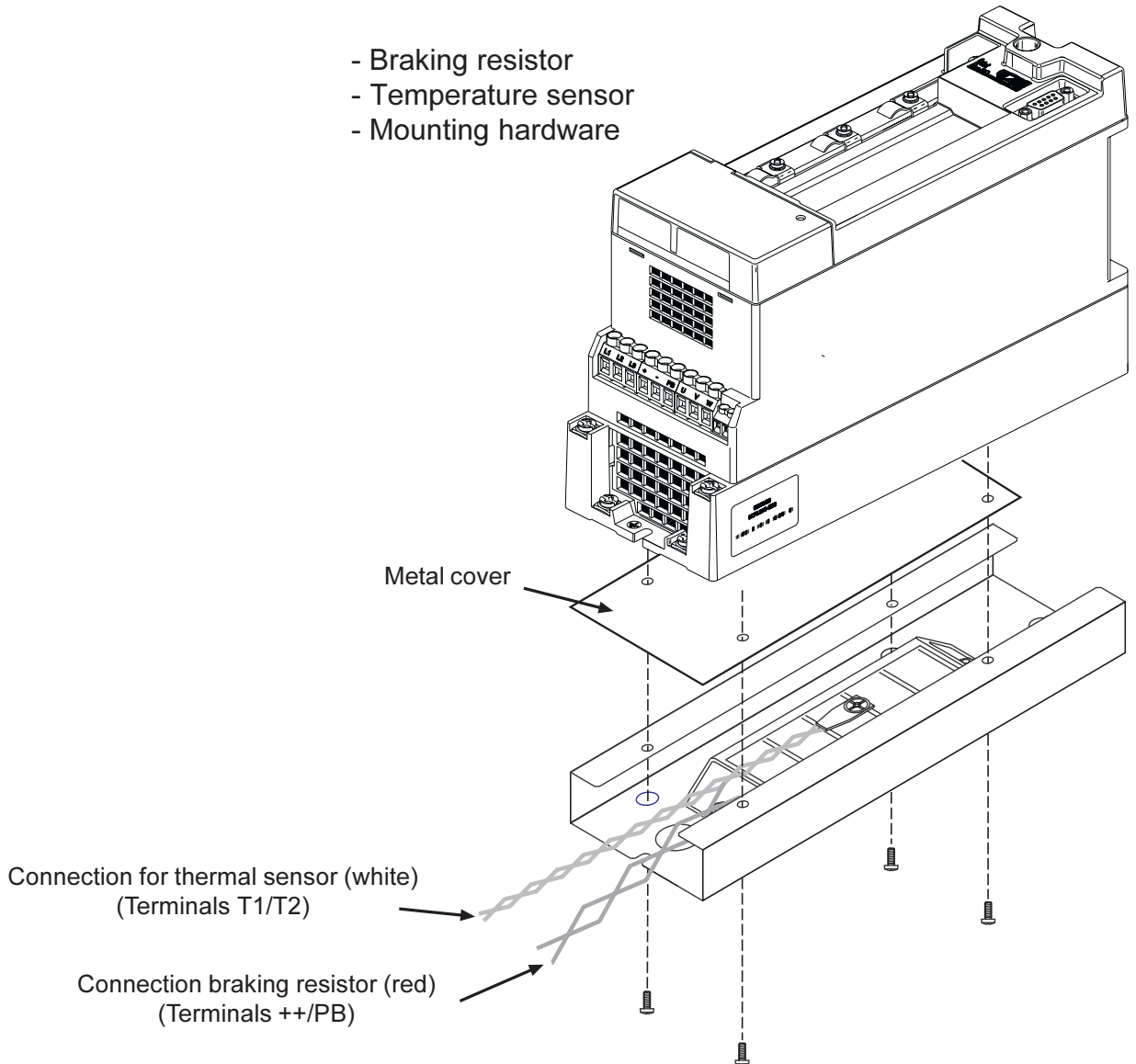

Use with 230V inverters size		07,09	10	09,10,12	13	14
Use with 460V inverters size		07,09,10	10,12	10,12,13,14	12,13,14,	13,14,15
Housing		B	B	D	E	E
Braking resistor	[Ω]	160	82	82	60	60
Continuous power dissipation	[W]	35	35	35	60	2 x 60
One time peak power (max. 3s) 230V	[W]	900	1700	1700	2400	2400
One time peak power (max. 3s) 460V	[W]	3400	6650	6650	9100	9100
Power at 5% d.c.f.	[W]	700	700	700	1200	2400
Power at 10% d.c.f.	[W]	350	350	350	600	1200
Power at 20% d.c.f.	[W]	175	175	175	300	600
Power at 40% d.c.f.	[W]	90	90	90	150	300
Weight	lb	2	2	2	3	3.5
Partnumber of the kit		09.F5.B90-0300	12.F5.B90-0300	12.F5.D90-4300	14.F5.E90-4300	15.F5.E90-4300

Accessories

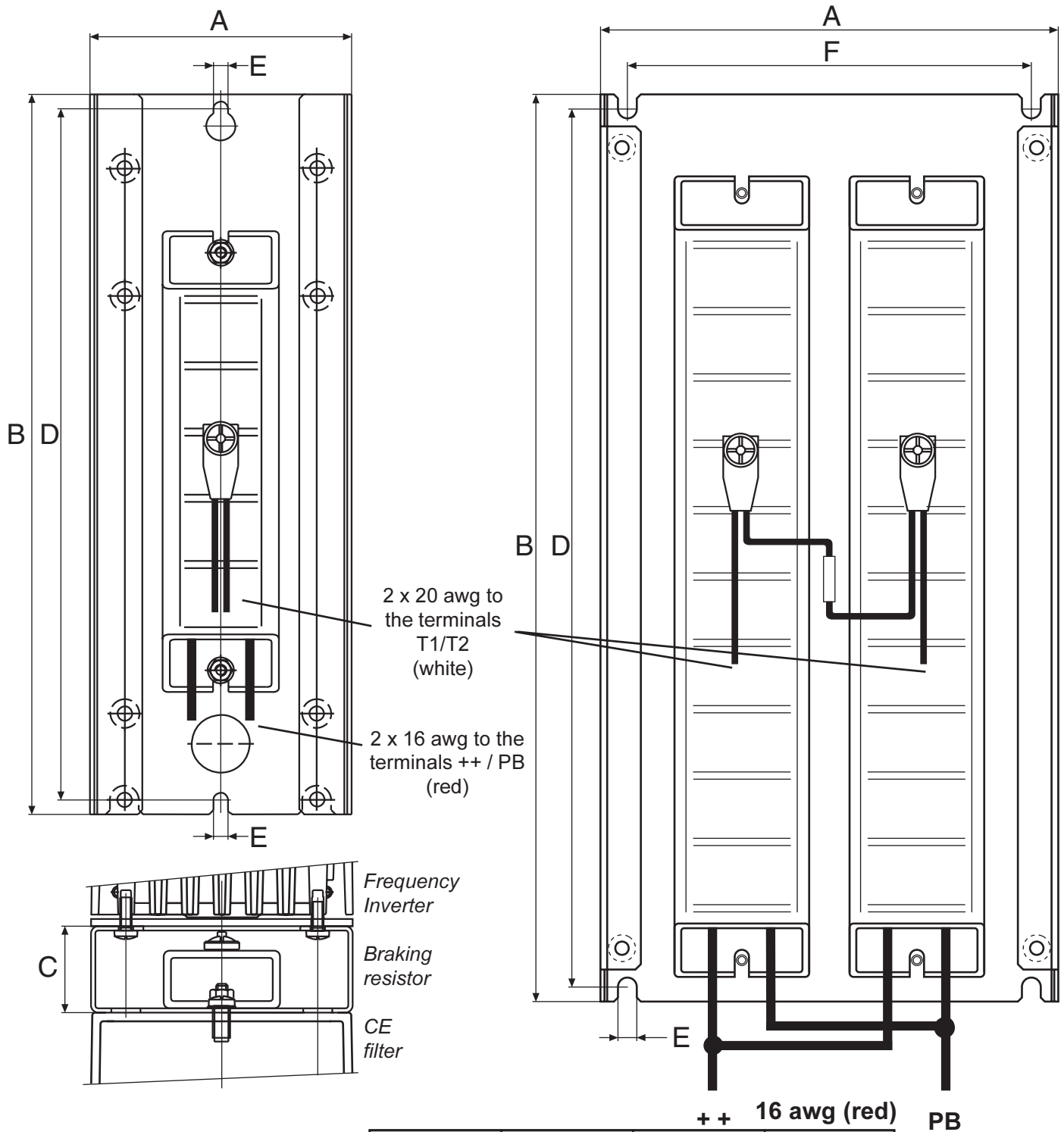

Dimensions
Back mount braking resistors

Housing ->	B	D	E
A [in]	3.5	3.5	5.1
B [in]	8.7	9.8	11.4
C [in]	1.2	1.2	1.2
D [in]	8.4	9.5	10.8
E [in]	0.20	0.20	0.28
F [in]	-	-	5.9

3.2 Input Filters

3.2.1 Line Choke The KEBCO line choke reduces the harmonics of the input current and the displacement power factor of the inverter improves from 0.5... 0.6 to approximately 0.8... 0.9.

Conducted high frequency interference is reduced up to 30 db in the frequency range from 10 kHz to approximately 300 kHz.

In addition, the noise immunity of the system is improved and the lifetime of the DC-bus capacitors increases.

Connection of the line choke

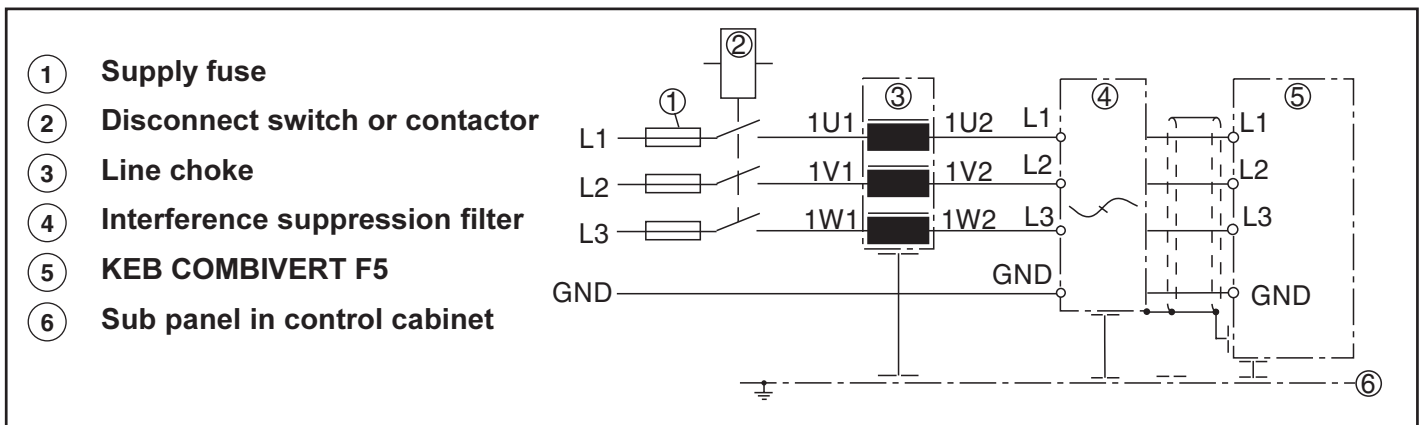

Line Chokes - Additional Information

Interference and or voltage spikes on the supply voltage are created when large loads such as heaters, motors, arc-welders etc. are turned on and off. In some instances, switching in and out large power factor correction capacitors either in the factory or on the utility grid can also lead to large voltage spikes appearing at the inverter. These spikes are typically short in time duration but high enough in voltage to create nuisance tripping of the inverter (i.e. over voltage). The voltage spike enters the inverter and raises the DC bus voltage level above the predefined limit, 400V in 230V units and 800V in 460V units. The protection circuits in the inverter activate leading to an interruption in the operation of the unit. The choke prevents these spikes from reaching the inverter eliminating the problem. 3% impedance chokes are generally sufficient. However 5% will help further reduce harmonic current on the line and will allow the system to better comply with the IEEE519 standard.

When installing larger inverters (100 hp and greater), harmonic distortion in the line current can become a problem. This distortion is caused by the diode bridge rectifier which serves as the input to all inverters. This distortion can create large fluctuations in the line voltage within a facility leading to problems with other equipment. The choke reduces the distortion of the current, there by eliminating the associated problems.

Accessories

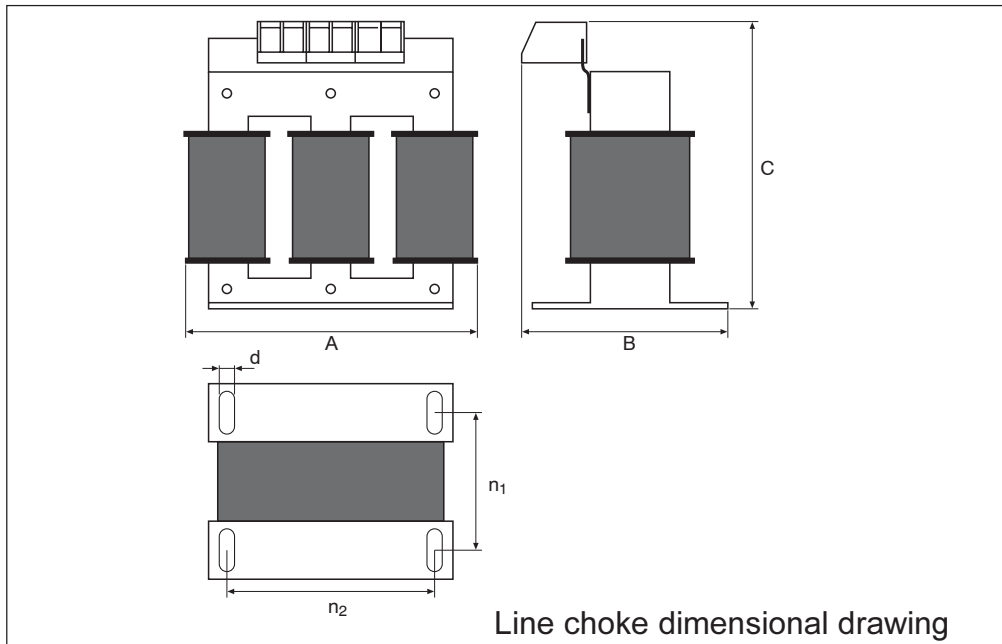

230V-Class													
For hp	Phases	I _N [A]	P _{loss} [W]	Imp. [%]	Part number	Dimensions [inches]						Wire awg	Weight [lb]
						A	B	C	n ₁	n ₂	d		
1	3	4	14.5	3	U0.90.290-0401	4.4	2.75	4.1	1.98	1.44	0.31 x 0.56	22-14	4
			20	5	U0.90.290-0402								
2	3	8	19.5	3	U0.90.290-0801	6	3	4.75	2.1	2	0.31 x 0.62	22-14	7
			29	5	U0.90.290-0802								8
3	3	12	26	3	U0.90.290-1201	6	3.25	5	2.1	2	0.31 x 0.62	22-5	9
			31	5	U0.90.290-1202								10
5	3	18	36	3	U0.90.290-1801	6	3.25	5.25	2.1	2	0.31 x 0.62	22-5	9
			43	5	U0.90.290-1802		3.5		2.48				12
7.5	3	25	48	3	U0.90.290-2501	7.25	3.43	6	2.35	3	0.38 x 0.75	22-5	11
			52	5	U0.90.290-2502								14
10	3	35	49	3	U0.90.290-3501	7.25	4	5.75	2.6	3	0.38 x 0.75	22-5	14
			54	5	U0.90.290-3502				2.75				16
15	3	45	54	3	U0.90.290-4501	9	4.75	7.35	3.16	3	0.38 x 0.75	18-4	23
			62	5	U0.90.290-4502								28
20	3	55	64	3	U0.90.290-5501	9	4.66	7.35	3.16	3	0.38 x 0.75	18-4	24
			67	5	U0.90.290-5502								27
25	3	80	82	3	U0.90.290-8001	10.8	5.62	8.5	3.47	3.63	0.38 x 0.75	22-1	43
			86	5	U0.90.290-8002								51
30	3	100	94	3	U0.90.291-0001	11	7	8.5	3.47	3.63	0.38 x 0.75	6-0	47
			84	5	U0.90.291-0002		6.63		3.66				51
40	3	130	108	3	U0.90.291-3001	9	6.38	7.25	3.16	3	3.75 x 0.56	2-0000	29
			84	5	U0.90.291-3002								11.25
50	3	160	116	3	U0.90.291-6001	10.8	6.75	8.5	3.16	3.63	0.38 x 0.75	2-0000	42
			149	5	U0.90.291-6002				3.47				3.63
60	3	200	124	3	U0.90.292-0001	10.8	7.25	8.5	4.16	3.63	0.38 x 0.75	2-0000	49
			168	5	U0.90.292-0002				11.5				8.25

Dimensions in inches

460V-Class													
For hp	Phases	I _N [A]	P _{loss} [W]	Imp. %	Part number	Dimensions						Wire [awg]	Weight [lb]
						A	B	C	n1	n2	d		
1	3	2	7.5	3	U0.90.290-0201								4
			11.3	5	U0.90.290-0202	4.4	2.75	4.1	1.98	1.44	0.31 x 0.56	22..14	4
2	3	4	20	3	U0.90.290-0402		4.75		1.98				4
			25	5	U0.90.290-0403	4.4	3.12	4.1	2.35	1.44	0.31 x 0.56	22..14	4
3	3	4	20	3	U0.90.290-0402		4.75		1.98				4
			25	5	U0.90.290-0403	4.4	3.12	4.1	2.35	1.44	0.31 x 0.56	22..14	4
5	3	8	29	3	U0.90.290-0802		3		2.1				8
			25.3	5	U0.90.290-0803	6	3.37	4.75	2.48	2	0.31 x 0.62	22..14	11
7.5	3	12	31	3	U0.90.290-1202		3.25		2.1				10
			41	5	U0.90.290-1203	6	3.87	5	2.75	2	0.31 x 0.62	22...5	18
10	3	18	43	3	U0.90.290-1802	6	3.5	5.25	2.48				12
			43	5	U0.90.290-1803	8	4	6	2.6	2	0.31 x 0.62	22...5	16
15	3	25	52	3	U0.90.290-2502		3.43		2.35				14
			61	5	U0.90.290-2503	7.25	4.25	6	3.1	3	0.38 x 0.75	22...5	20
20	3	35	54	3	U0.90.290-3502	7.25	4	5.75	2.75			22...5	16
			54	5	U0.90.290-3503	9	4.75	7.5	3.16	3	0.38 x 0.75	18...4	30
25	3	35	54	3	U0.90.290-3502	7.25	4	5.75	2.75			22...5	16
			54	5	U0.90.290-3503	9	4.75	7.5	3.16	3	0.38 x 0.75	18...4	30
30	3	45	62	3	U0.90.290-4502		4.75	7.35	3.16				28
			65	5	U0.90.290-4503	9	5.3	7.25	3.66	3	0.38 x 0.75	18...4	39
40	3	55	67	3	U0.90.290-5502		4.66	7.35	3.16				27
			71	5	U0.90.290-5503	9	5.41	7.5	3.91	3	0.38 x 0.75	18...4	41
50	3	80	86	3	U0.90.290-8002		5.62		3.47			12...1	51
			96	5	U0.90.290-8003	10.8	6.75	8.5	4.16	3.63	0.38 x 0.75	6...0	61
60	3	80	86	3	U0.90.290-8002		5.62		3.47			12...1	51
			96	5	U0.90.290-8003	10.8	6.75	8.5	4.16	3.63	0.38 x 0.75	6...0	61
75	3	100	84	3	U0.90.291-0002		6.63		3.66				51
			108	5	U0.90.291-0003	11	7.62	8.5	4.16	3.63	0.375 x 0.75	6...0	74
100	3	130	180	3	U0.90.291-3002		6.63		3.66				62
			128	5	U0.90.291-3003	11.25	8.5	8.5	4.18	3.63	0.38 x 0.75	2...4/0	64
125	3	160	149	3	U0.90.291-6002	11	7		3.47				51
			138	5	U0.90.291-6003	11.25	8	8.5	4.66	3.63	0.38 x 0.75	2...4/0	72
150	3	200	168	3	U0.90.292-0002		8.25		4.41				67
			146	5	U0.90.292-0003	11.5	10	8.5	5.91	3.63	0.38 x 0.75	2...4/0	100
175	3	250	231	3	U0.90.292-5002	15	10.3		5.16				106
			219	5	U0.90.292-5003	14.5	11.3	11.3	5.82	4.6	0.56	2/0..500	143
200	3	250	231	3	U0.90.292-5002	15	10.3		5.16				106
			219	5	U0.90.292-5003	14.5	11.3	11.3	5.82	4.6	0.56	2/0..500	143

Dimensions in inches

Accessories

3.2.2 EMI (CE) - Filter

The KEBCO COMBIVERT frequency inverters are optionally available with EMI filters. Depending on the housing size they are available from the factory already mounted to the inverter or as filter kits for installation by the user. These filters allow the KEBCO COMBIVERT to meet the CE EMC directive 89/339. All filters are dimensioned for the inverter's rated current and are designed to meet the conducted emission limit as defined by EN55011/B. If the motor wires are shielded and longer than the maximum values listed in the tables on pages 15-20, consult KEBCO for the proper filter. Also for a delta connected line or for a low ground leakage filter solutions contact KEBCO.

The filter kits contain all required hardware for installation. Filters for sizes up to 200 hp include the shielded supply wires which connect the filter to the inverter. Depending on the available space and filter type, the filter can either be installed under the frequency inverter (sub-mounted), or beside the frequency inverter (side mounted).

EMI (CE) - Filter 230V-Class				
For Inverter size / housing	Phases	Kit incl. Filter	Filter	Back mounting with housing
05,07 / A	1	internal option	-	-
07 / B	1	07.U5.B0B-1010	07.E5.T60-0061	B
09,10 / B	1	10.U5.B0B-1000	10.E5.T60-0001	B
09,10 / D	1	10.U5.B0D-1000	10.E5.T60-0002	D
07,09,10 / B	3	10.U5.B0B-2000	12.E5.T60-1001	B
09,10 / D	3	10.U5.B0D-2000	13.E5.T60-1001	D
12 / D	3	12.U5.B0D-2000	14.E5.T60-1001	D
13 / E	3	13.U5.B0E-2000	15.E4.T60-1001	E
14 / E	3	14.U5.B0E-2000	16.E5.T60-1001	E
14,15 / G	3	15.U5.B0G-2000	16.E4.T60-1001	G
15,16 / H	3	16.U5.B0H-2000	19.E4.T60-1001	H
17,18 / R	3	18.U5.B0R-2000	20.E4.T60-1001	R
19 / R	3	19.U5.B0R-2000	22.E4.T60-1001	R
20,21 / R	3	21.U5.B0R-2000	23.E4.T60-1001	side mount

EMI (CE) Filter 460V-Class				
For Inverter Size / housing	Phases	Kit incl. Filter	Filter	Back mount with housing
07,09,10 / B	3	10.U5.B0B-3000	10.E5.T60-1001	B
07,09,10 / D	3	10.U5.B0D-3000	10.E5.T60-1002	D
12 / B	3	12.U5.B0B-3000	12.E5.T60-1001	B
12,13 / D	3	13.U5.B0D-3000	13.E5.T60-1001	D
14 / D	3	14.U5.B0D-3000	14.E5.T60-1001	D
12,13,14 / E	3	14.U5.B0E-3000	14.E4.T60-1001	E
15 / E	3	15.U5.B0E-3000	15.E4.T60-1001	E
16,17 / G	3	17.U5.B0G-3000	16.E4.T60-1001	G
18 / H	3	18.U5.B0H-3000	18.E4.T60-1001	H
19 / H	3	19.U5.B0H-3000	19.E4.T60-1001	H
20 / R	3	20.F5.x3R-xxxx	20.E4.T60-1001	internal mount
21,22,23 / R	3	2x.F5.x3R-xxxx	22.E4.T60-1001	internal mount
23 / U	3	23.U5.B0U-3000	23.E4.T60-1001	side mount
24,25 / U	3	25.U5.B0U-3000	25.F4-T60-1001	side mount
26,27 / U	3	27.U5.B0U-3000	27.E4-T60-1001	side mount

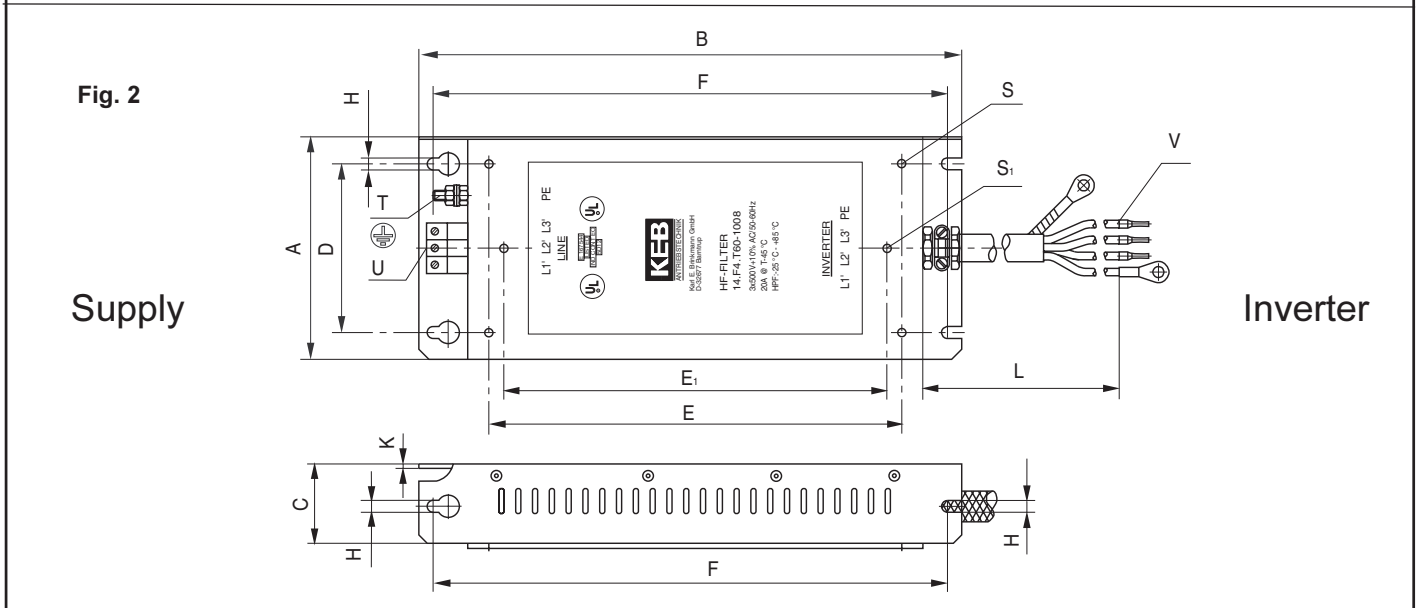
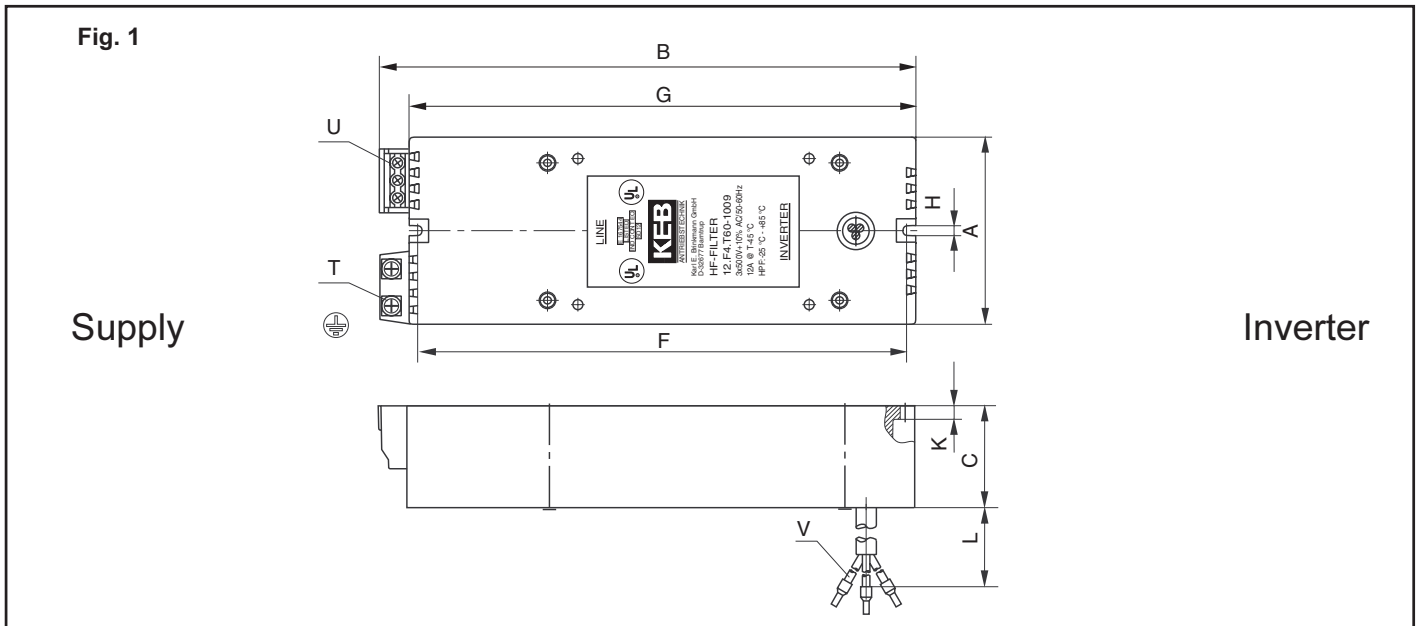

Rated current	Voltage	V max.	Fig.	A	B	C	D	E	E1	F	G	H	K	S	S1	T	LINE	INVERTER	L	Weight [lbs]	
																	U	V			
KEB Art.No.:	[V]	[A]															Terminal Strip	Shielded Cable			
07.E5.T60-0061	1x250	8	1	3.5	9.8	1.6	-	-	-	-	-	0.2	0.2	-	-	-	2x 4mm ²	2x AWG 14	4.33	2.0	
10.E5.T60-0001		22			11.2												2x AWG 10				
10.E5.T60-0002		22			2x AWG 10																
10.E5.T60-1001	3x500	8	1	3.5	9.8	1.6	-	-	-	-	0.2	0.2	-	-	M4	3x 4mm ²	3x AWG 10	3x AWG 14	15.7	3.3	
10.E5.T60-1002		8			11.2																3x AWG 14
12.E5.T60-1001		16			9.8																4x AWG 12
13.E5.T60-1001	16	11.2	2.0																		
14.E5.T60-1001	22																				
14.E4.T60-1001	3x500	22	2	5.2	13.9	2.0	3.9	-	10.8	13.2	-	0.3	0.1	-	M6	M6	3x 10mm ²	4x AWG 10	15.7	3.3	
15.E4.T60-1001		30																			
16.E5.T60-1001		50																			
16.E4.T60-1001	50	7.1	16.3	2.2	5.9	13.0	-	15.7	-	0.3	0.1	M6	-	M6		3x 25mm ²	4x AWG 8	15.7	7.0		
18.E4.T60-1001	65	11.8	17.5	2.6	9.8	13.0	-	16.5	-	0.3	0.2	M6	-	M6		3x 25mm ²	4x AWG 6	13.8	11.2		
19.E4.T60-1001	75																3x AWG 2	4x AWG 4	13.8	13.4	

Dimensions in inches unless specified otherwise

Accessories

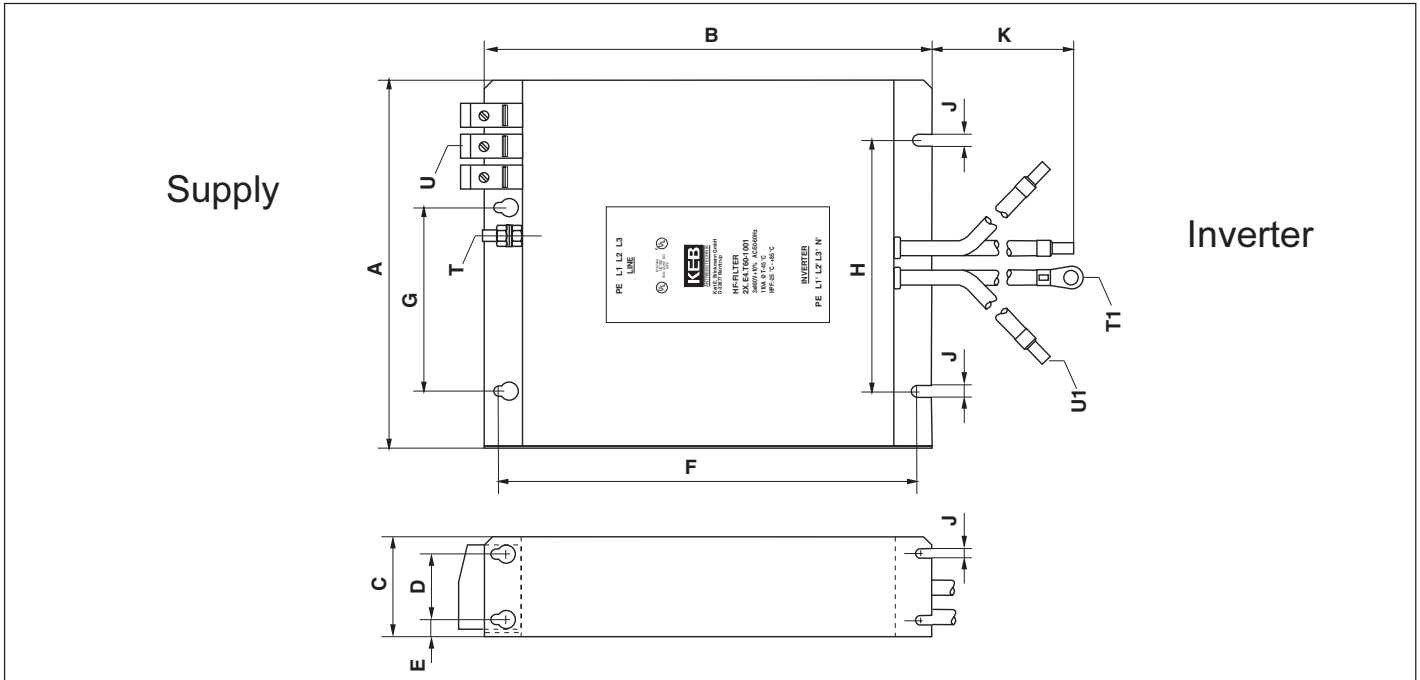

Rated Current				Pv	A	B	C	D	E	F	G	H	I	K	LINE		INVERTER		Wt. [lbs]
Maximum Voltage		T	U												T1	U1			
KEB Art.Nr.:	[V]	[A]	[W]												[mm]		[mm]		
20.E4.T60-1001	3x	110	58		10.6	15.7	2.5	1.57	0.47	15.2	5.5	7.87	0.26	15.7	M8	3x 50	3x25	for	15.8
22.E4.T60-1001	500	130	90														3x35	M8	17.4

Dimensions in inches unless specified otherwise

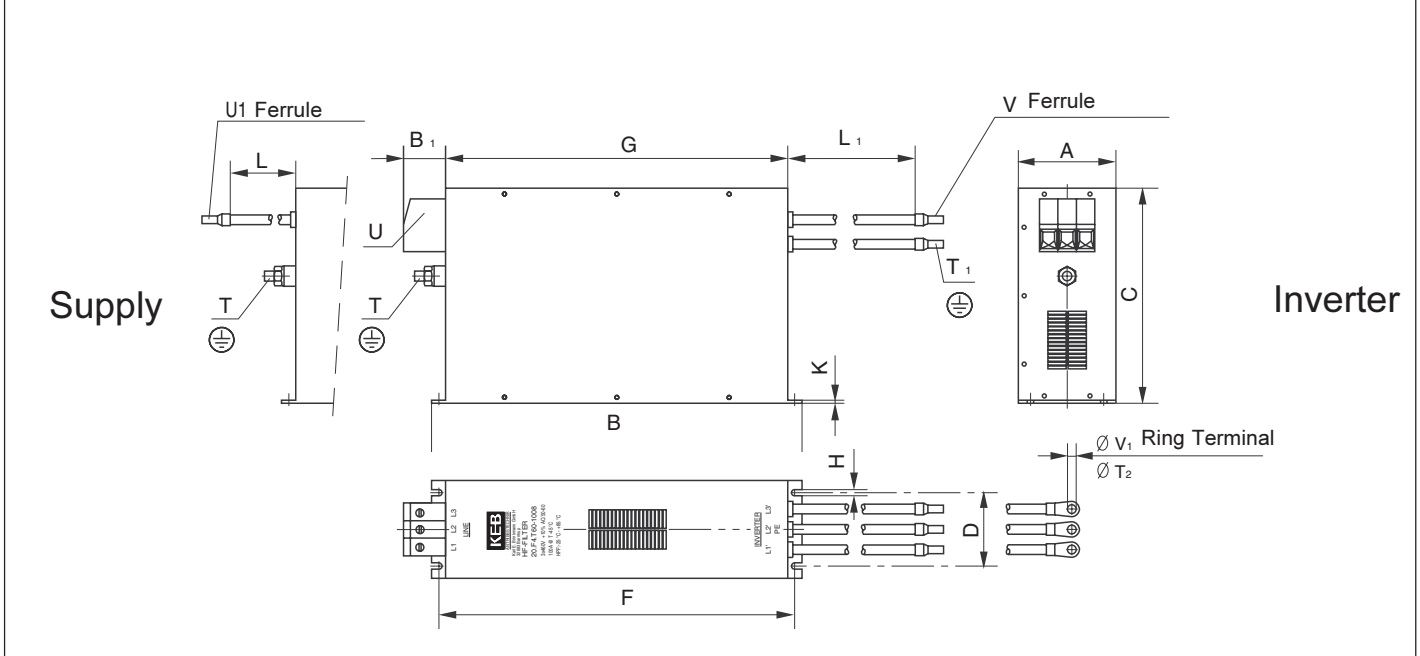

Rated Current				Pv	A	B	B1	C	D	F	G	H	K	L	L1	LINE			INVERTER			Wt. [lbs]	
Maximum Voltage		T	U													U1	T1	T2	V	V1			
KEB Art.Nr.:	[V]	[A]	[W]													Terminal cross sec.	Wire dia. [mm ²]	Wire dia. [mm ²]	Wire dia. [mm]	Wire dia. [mm ²]			
23.E4.T60-1001	3x	180	102		18.7	-	9.4	3.1	17.8	17.3	0.26	0.16	40.9	21.7	M10	-	3x95	-	M8	3x95	-	31.9	
25.E4.T60-1001	500	250	116	4.3	24.8	-	9.4	3.1	9.4	9.4									M10	3x95	-	31.9	
27.E4.T60-1001		330	137																	M10	3x150	-	37.6

Dimensions in inches unless otherwise specified

3.3 Output Filters

3.3.1 Motor Choke

There are several reasons to install a choke between the inverter and the motor. These reasons depend on the following variables: operating voltage, inverter size, motor type, motor cable type (shielded or not) and motor cable length. The conditions around the usage of the chokes are described below.

Shielded motor cables are recommended to reduce the possibility of noise interfering with other components, i.e. sensors, controllers. However by shielding the wires, a good capacitance coupling to earth ground is created. As the motor cable length increases, the coupling capacitance increases, resulting in higher ground leakage currents and higher levels of conducted EMI on the line. As a result, with longer shielding cables the inverter and KEB EMI filter may no longer comply with the EN norm regarding conducted interference. Thus it is necessary to use a motor choke to reduce these levels.

If the inverter is rated for 1, 2 and 3 hp and it is operated with a high carrier frequency, it may be necessary to use a motor choke even with relatively short cable lengths. Capacitive current flows between the motor leads U,V,W and to ground via the shield, as a result adding to the motor current. The resulting current typically exceeds the rated current of the inverter causing nuisance over load or over current faults. This does not effect the larger hp units since the capacitive current is proportional to the cable length and is roughly the same for all sizes of inverters.

When the motor cables are 100 to 150 feet in length, voltage peaks several times greater than the rated voltage of the motor can begin to appear at the motor. By using motors which have a high insulation breakdown rating, usually listed in volts (1600V or higher), the choke can be eliminated. However, if standard motors with normal insulation ratings are used, the choke is highly recommended.

Finally, as the motor cables become longer, it is possible for voltage peaks to appear at the motor and the inverter's terminal strip. In this case the motor windings may have a high insulation rating protecting the motor, but the inverter has only a 1200V rating on the power IGBTs. As a result a motor choke is always recommended when the cables are longer.

Taking all these factors into consideration, the maximum cable length, per inverter size and carrier frequency is listed in the tables on pages 15-20. For cable lengths greater than list a choke is recommended.

Choke sizing-motor chokes should be selected such that the rated current of the choke is equal to or greater than the rated current of the inverter. Three percent chokes are sufficient. However, 5% chokes will reduce the audible PWM noise in the motor when operating at lower carrier frequencies.

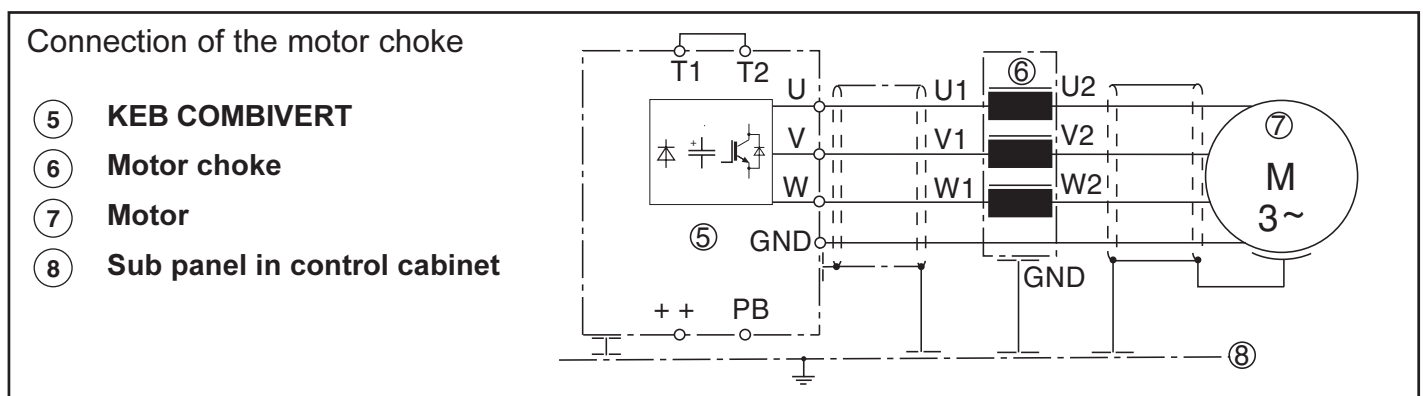

Accessories

Motor choke dimensional drawing

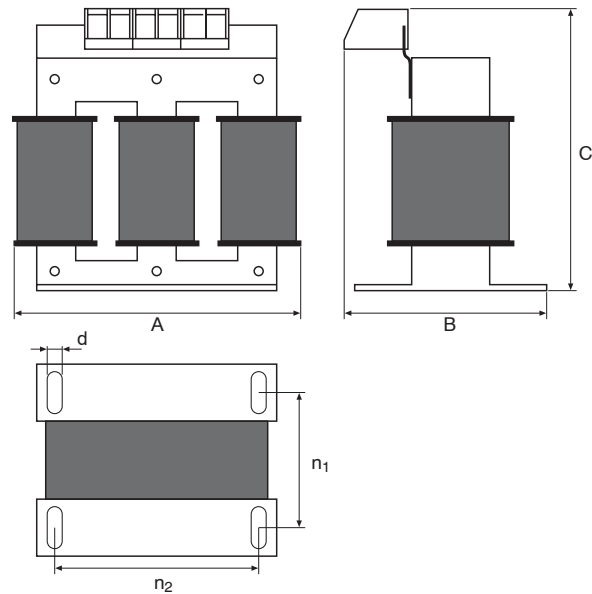

230V-Class

For hp	Phases	I _N [A]	P _{loss} [W]	Imp. [%]	Part number	Dimensions [inches]						Wire awg	Weight [lb]
						A	B	C	n ₁	n ₂	d		
1	3	4	14.5	3	U0.90.290-0401	4.4	2.75	4.1	1.98	1.44	0.31 x 0.56	22-14	4
			20	5	U0.90.290-0402								
2	3	8	19.5	3	U0.90.290-0801	6	3	4.75	2.1	2	0.31 x 0.62	22-14	8
			29	5	U0.90.290-0802								
3	3	12	26	3	U0.90.290-1201	6	3.25	5	2.1	2	0.31 x 0.62	22-5	10
			31	5	U0.90.290.1202								
5	3	18	36	3	U0.90.290-1801	6	3.25	5.25	2.1	2	0.31 x 0.62	22-5	12
			43	5	U0.90.290-1802								
7.5	3	25	48	3	U0.90.290-2501	7.25	3.43	6	2.35	3	0.38 x 0.75	22-5	14
			52	5	U0.90.290-2502								
10	3	35	49	3	U0.90.290-3501	7.25	4	5.75	2.6	3	0.38 x 0.75	22-5	14
			54	5	U0.90.290-3502								
15	3	45	54	3	U0.90.290-4501	9	4.75	7.35	3.16	3	0.38 x 0.75	18-4	23
			62	5	U0.90.290-4502								
20	3	55	64	3	U0.90.290-5501	9	4.66	7.35	3.16	3	0.38 x 0.75	18-4	24
			67	5	U0.90.290-5502								
25	3	80	82	3	U0.90.290-8001	10.8	5.62	8.5	3.47	3.63	0.38 x 0.75	22-1	43
			86	5	U0.90.290-8002								
30	3	100	94	3	U0.90.291-0001	11	7	8.5	3.47	3.63	0.38 x 0.75	6-0	47
			84	5	U0.90.291-0002								
40	3	130	108	3	U0.90.291-3001	9	6.38	7.25	3.16	3	3.75 x 0.56	2-0000	29
			84	5	U0.90.291-3002								
50	3	160	116	3	U0.90.291-6001	10.8	6.75	8.5	3.16	3.63	0.38 x 0.75	2-0000	42
			149	5	U0.90.291-6002								
60	3	200	124	3	U0.90.292-0001	11.5	7.25	8.5	4.16	3.63	0.38 x 0.75	2-0000	49
			168	5	U0.90.292-0002								

Dimensions in inches

460V-Class													
For hp	Phases	I _N [A]	P _{loss} [W]	Imp. %	Part number	Dimensions						Wire [awg]	Weight [lb]
						A	B	C	n1	n2	d		
1	3	2	7.5	3	U0.90.290-0201								4
			11.3	5	U0.90.290-0202	4.4	2.75	4.1	1.98	1.44	0.31 x 0.56	22..14	4
2	3	4	20	3	U0.90.290-0402		4.75		1.98				4
			25	5	U0.90.290-0403	4.4	3.12	4.1	2.35	1.44	0.31 x 0.56	22..14	4
3	3	4	20	3	U0.90.290-0402		4.75		1.98				4
			25	5	U0.90.290-0403	4.4	3.12	4.1	2.35	1.44	0.31 x 0.56	22..14	4
5	3	8	29	3	U0.90.290-0802		3		2.1				8
			25.3	5	U0.90.290-0803	6	3.37	4.75	2.48	2	0.31 x 0.62	22..14	11
7.5	3	12	31	3	U0.90.290-1202		3.25		2.1				10
			41	5	U0.90.290-1203	6	3.87	5	2.75	2	0.31 x 0.62	22...5	18
10	3	18	43	3	U0.90.290-1802	6	3.5	5.25	2.48				12
			43	5	U0.90.290-1803	8	4	6	2.6	2	0.31 x 0.62	22...5	16
15	3	25	52	3	U0.90.290-2502		3.43		2.35				14
			61	5	U0.90.290-2503	7.25	4.25	6	3.1	3	0.38 x 0.75	22...5	20
20	3	35	54	3	U0.90.290-3502	7.25	4	5.75	2.75			22...5	16
			54	5	U0.90.290-3503	9	4.75	7.5	3.16	3	0.38 x 0.75	18...4	30
25	3	35	54	3	U0.90.290-3502	7.25	4	5.75	2.75			22...5	16
			54	5	U0.90.290-3503	9	4.75	7.5	3.16	3	0.38 x 0.75	18...4	30
30	3	45	62	3	U0.90.290-4502		4.75	7.35	3.16				28
			65	5	U0.90.290-4503	9	5.3	7.25	3.66	3	0.38 x 0.75	18...4	39
40	3	55	67	3	U0.90.290-5502		4.66	7.35	3.16				27
			71	5	U0.90.290-5503	9	5.41	7.5	3.91	3	0.38 x 0.75	18...4	41
50	3	80	86	3	U0.90.290-8002		5.62		3.47			12...1	51
			96	5	U0.90.290-8003	10.8	6.75	8.5	4.16	3.63	0.38 x 0.75	6...0	61
60	3	80	86	3	U0.90.290-8002		5.62		3.47			12...1	51
			96	5	U0.90.290-8003	10.8	6.75	8.5	4.16	3.63	0.38 x 0.75	6...0	61
75	3	100	84	3	U0.90.291-0002		6.63		3.66				51
			108	5	U0.90.291-0003	11	7.62	8.5	4.16	3.63	0.375 x 0.75	6...0	74
100	3	130	180	3	U0.90.291-3002		6.63		3.66				62
			128	5	U0.90.291-3003	11.25	8.5	8.5	4.18	3.63	0.38 x 0.75	2...4/0	64
125	3	160	149	3	U0.90.291-6002	11	7		3.47				51
			138	5	U0.90.291-6003	11.25	8	8.5	4.66	3.63	0.38 x 0.75	2...4/0	72
150	3	200	168	3	U0.90.292-0002		8.25		4.41				67
			146	5	U0.90.292-0003	11.5	10	8.5	5.91	3.63	0.38 x 0.75	2...4/0	100
175	3	250	231	3	U0.90.292-5002	15	10.3		5.16				106
			219	5	U0.90.292-5003	14.5	11.3	11.3	5.82	4.6	0.56	2/0..500	143
200	3	250	231	3	U0.90.292-5002	15	10.3		5.16				106
			219	5	U0.90.292-5003	14.5	11.3	11.3	5.82	4.6	0.56	2/0..500	143

Dimensions in inches

3.3.2 PWM to Sine Filter

When controlling the motor with pulse width modulation (PWM), the motor can be subject to very rapid voltage rise times, dv/dt of 5...10kV/uSec. This rapid turn on can create many side effects with long cable runs greater than 150 feet, the primary problem being voltage peaks either at the motor or at the inverter. If a motor with suitable winding insulation is used then the inverter becomes the limiting factor since the output transistors are only rated for 1200V.

Installing a PWM to sine filter converts the PWM voltage to standard AC sine wave voltage phase to phase. As a result all of the problems associated with long cable runs, high dv/dt , and high voltage peaks are eliminated. The phase to ground voltage still contains some PWM voltage therefore shielded motor cables are still recommended. The standard-PWM to sine filters are designed for a maximum output frequency of 120 Hz.

For more information consult KEBCO. Ask for our AF series output filters.

3.3.3 PWM to Sine Filter Plus

The KEBCO PWM to sine filter plus creates sinusoidal voltages phase to phase and phase to ground. All problems with long motor leads are eliminated and it is no longer necessary to use shielded motor cable. This filter is recommended for extremely long motor cables, >300ft. Additionally, these filters can be used when retrofitting older installations with inverters. The filter allows the use of the existing motor cables instead of requiring a new shielded cable to be installed.

With loads >150% inverter-rated current (I_N) the next higher filter must be used. Min. 8 kHz (better 16 kHz) carrier frequency are required. The filter is dimensioned for a maximum output frequency of 100 Hz.

For more information consult KEBCO. Ask for our AF series output filters.

4. Annex

4.1 Overload Characteristic

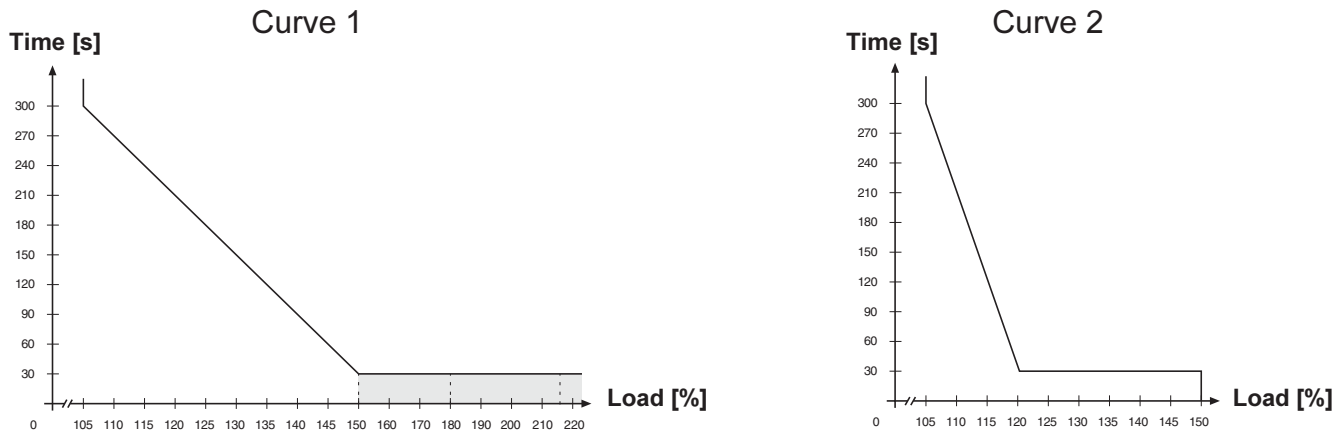

The characteristic declines device-dependently in this range (see rating plate)

On exceeding a load of 105% the overload timer starts. When falling below the timer counts backwards. If the timer achieves value for the overload characteristic that corresponds to the inverter, the error E.OL is triggered.

4.2 Overload protection in the lower speed range

(only valid for F5-M and F5-S, stall current see technical data)

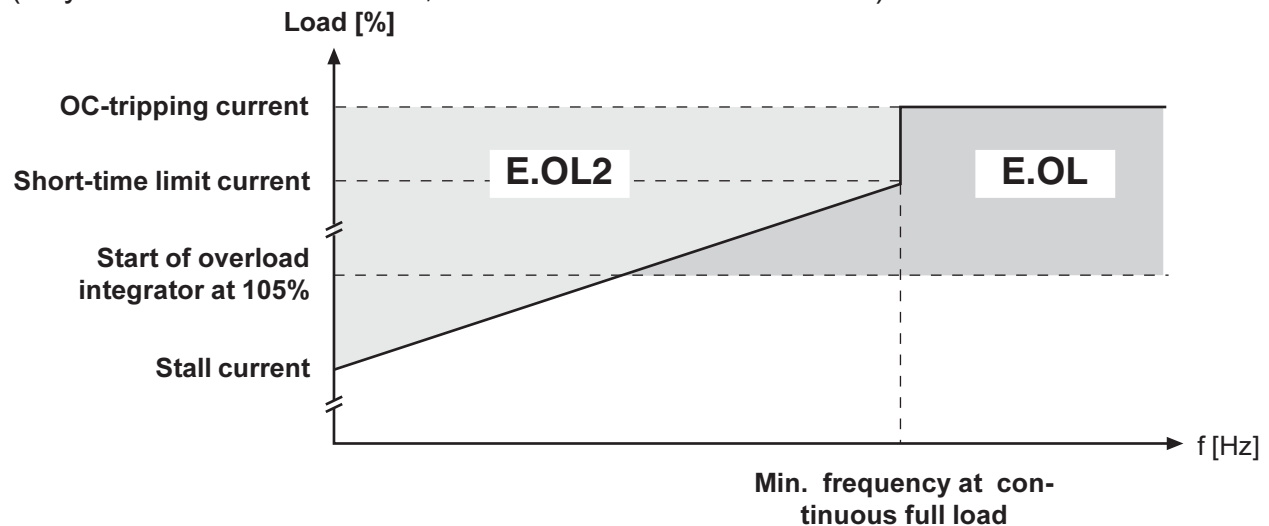

If the permissible current is exceeded a PT1-element ($\tau=280\text{ms}$) starts, after its sequence of operation the error E.OL2 is triggered.

Special Notice to Customer



Prior to delivery all products pass several quality and performance inspections in order to guarantee the product is free from defects in manufacturing. When used in accordance with the operating instructions, failure of the unit is not likely. However, if you have reason for concern please contact KEBCO at 651-454-6162 and ask for "inverter technical support". From this point our technical support engineers can help you determine the cause of the problems and also the proper solution.

Listed values in this manual are standard values only and do not pertain to special units. We reserve the right to make technical changes without notification.

KEBCO Limited Warranty

KEBCO Inc. will repair or replace, at KEBCO's discretion, any inverter which shows signs of defect in material, workmanship or fails to meet factory specifications within one year from original date of shipment from KEBCO in St. Paul. Operation of the inverter outside the rated specifications printed in the instruction manuals will void the warranty.

KEBCO does not assume any liability for cost of removal, cost of installation, down time, production delays, return shipping, or damage to other items associated with the inverter, for failures which occur during or after the warranty period.

To make a warranty claim contact the Electronic repair department at the number listed above, and request a Return Goods Authorization (RGA) number. The inverter is to be shipped prepaid to the address listed below. Suitable packaging must be provided to prevent the inverter from incurring damages during shipping as damages of this nature will void the warranty.

KEBCO will inspect the inverter to determine the cause of the problems in the inverter and will repair or replace the inverter at its discretion.

**KEBCO Inc.
Attn. ELECTRONIC REPAIR (RGA#)
1335 Mendota Heights Road
St. Paul, MN 55120**



Karl E. Brinkmann GmbH

Försterweg 36 - 38 • D - 32683 Barntrup
Telefon 00 49 / 52 63 / 4 01 - 0 • Fax 00 49 / 52 63 / 4 01 - 1 16
Internet: www.keb.de • E-mail: info@keb.de

KEB Antriebstechnik GmbH & Co. KG

Wildbacher Str. 5 • D - 08289 Schneeberg
Telefon 0049 / 37 72 / 67 - 0 • Telefax 0049 / 37 72 / 67 - 2 81
E-mail: info@keb-combidrive.de

KEB Antriebstechnik Austria GmbH

Ritzstraße 8 • A - 4614 Marchtrenk
Tel.: 0043 / 7243 / 53586 - 0 • FAX: 0043 / 7243 / 53586 - 21
Kostelni 32/1226 • CZ - 370 04 České Budejovice
Tel.: 00420 / 38 / 731 92 23 • FAX: 00420 / 38 / 733 06 97
E-mail: info@keb.at

KEB Antriebstechnik

Herenveld 2 • B - 9500 Geraadsbergen
Tel.: 0032 / 5443 / 7860 • FAX: 0032 / 5443 / 7898
E-mail: koen.detaeye@keb.de

KEB China

Xianxia Road 299 • CHN - 200051 Shanghai
Tel.: 0086 / 21 / 62350922 • FAX: 0086 / 21 / 62350015
Internet: www.keb-cn.com • E-mail: info@keb-cn.com

Société Française KEB

Z.I. de la Croix St. Nicolas • 14, rue Gustave Eiffel
F - 94510 LA QUEUE EN BRIE
Tél.: 0033 / 1 / 49620101 • FAX: 0033 / 1 / 45767495
E-mail: sfkeb.4@wanadoo.fr

KEB (UK) Ltd.

6 Chieftain Business Park, Morris Close
Park Farm, Wellingborough, GB - Northants, NN8 6 XF
Tel.: 0044 / 1933 / 402220 • FAX: 0044 / 1933 / 400724
Internet: www.keb-uk.co.uk • E-mail: info@keb-uk.co.uk

KEB Italia S.r.l.

Via Newton, 2 • I - 20019 Settimo Milanese (Milano)
Tel.: 0039 / 02 / 33500782 • FAX: 0039 / 02 / 33500790
Internet: www.keb.it • E-mail: kebitalia@keb.it

KEB - YAMAKYU Ltd.

15 - 16, 2 - Chome, Takanawa Minato-ku
J - Tokyo 108 -0074
Tel.: 0081 / 33 / 445-8515 • FAX: 0081 / 33 / 445-8215
E-mail: kebjt001@d4.dion.ne.jp

KEB Portugal

Lugar de Salgueiros - Pavilhao A, Mouquim
P - 4760 V. N. de Famalicao
Tel.: 00351 / 252 / 371 318 • FAX: 00351 / 252 / 371 320
E-mail: keb.portugal@netc.pt

KEB Taiwan Ltd.

1F, No.19-5, Shi Chou Rd., Tounan Town
R.O.C. - Yin-Lin Hsian / Taiwan
Tel.: 00886 / 5 / 5964242 • FAX: 00886 / 5 / 5964240
E-mail: keb_taiwan@mail.apol.com.tw

KEB Sverige

Box 265, Bergavägen 19
S-430 93 Hälsö
Tel.: 0046 31 961520 • Fax: 0046 31 961935
E-mail: thomas.crona@keb.de

KEBCO Inc.

1335 Mendota Heights Road
USA - Mendota Heights, MN 55120
Tel.: 001 / 651 / 4546162 • FAX: 001 / 651 / 4546198
Internet: www.kebco.com • E-mail: info@kebco.com