

**BRICK**  
**Southeast**  
*a Brick Industry  
Association*

**Guide  
To**

*General  
Technical  
Reference*

# BRICK Construction

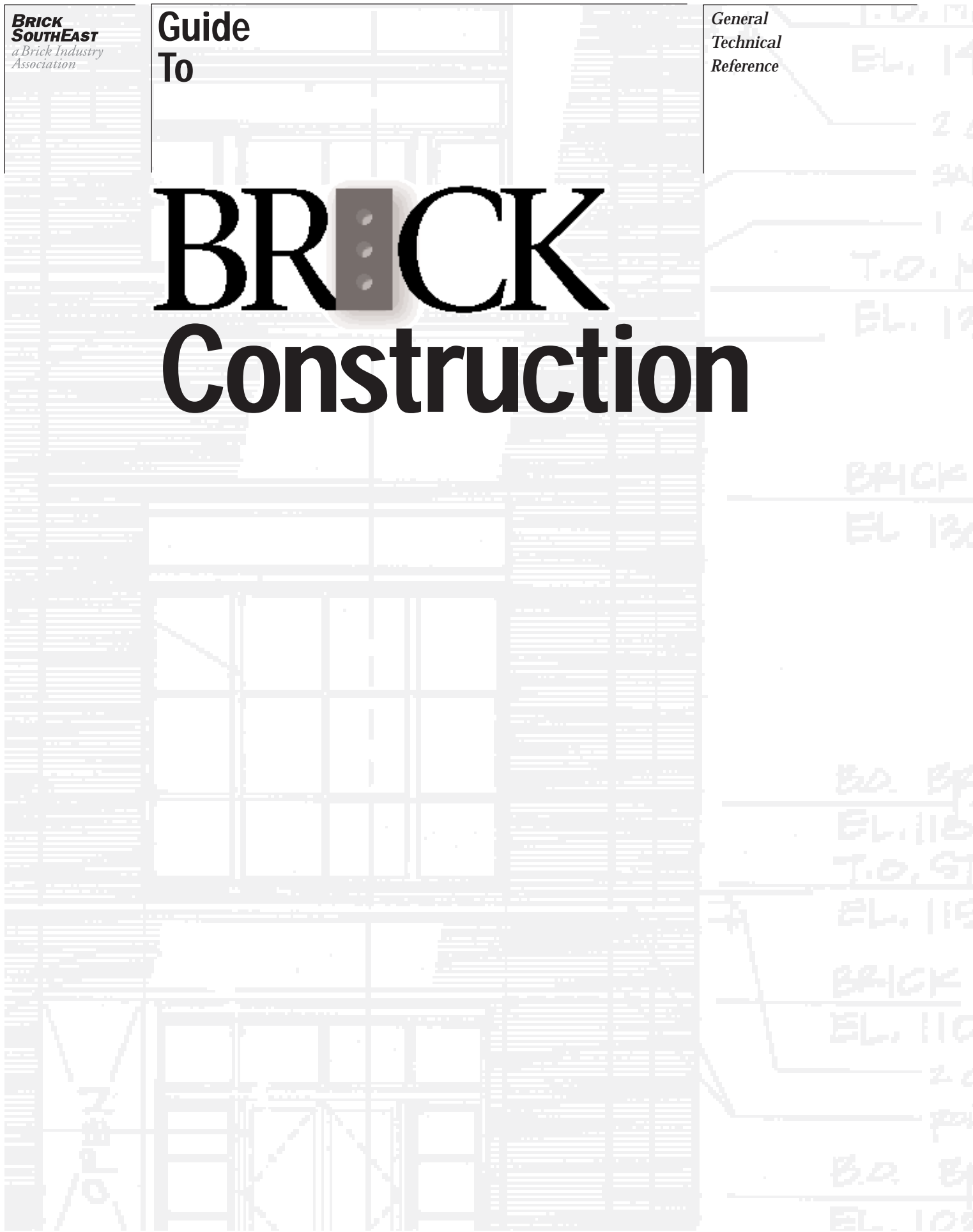

## Table of Contents

Types, Sizes and Estimating	1
Bonds, Joints and Positions	1
Wall Types	2
Insulating Brick Walls	3
Mortarless Interior Brick Flooring	4
Fireplaces	5
Arches	6
Quoin Corners & Water Table	7
Steps	8
Exterior Paving	9
Brick Driveways	10
Walkways & Patios	11
Brick Cleaning	12
Mailboxes	13
Garden Walls	14
Retaining Walls	15
Exterior Brick Siding	16
Brick Does Not Leak	17
Cold Weather Masonry	18
Garage Door Openings	19

## Introduction

This publication has been prepared as a guide to brick construction for the home builders. It is especially for the builder who may not be familiar with all areas of brick construction in the home building field.

We have attempted to cover particularly those details of construction which will be most often used. However, since we cannot cover all possibilities we hope you will ask for additional information when needed.

Simply contact:  
Brick SouthEast  
Suite 800  
8420 University Executive Park  
Charlotte, NC  
28262

800.62.BRICK/Charlotte, NC  
888.37.BRICK/Conyers, GA  
www.gobricksoutheast.com

## Important Note

The products described in this booklet involve the use of hazardous materials, operations and/or equipment. This booklet does not purport to address all of the safety practices associated with the use of these products. It is the responsibility of the user of this booklet to establish appropriate safety and health practices and to determine the applicability of regulatory limitations prior to the use of the products described.

The information and suggestions contained in this booklet are based on available data and experience of the technical staff of Brick SouthEast. This information should be recognized as recommendations and should be used with judgement. Final decisions on the use of the information discussed herein are not within the purview of Brick SouthEast and must rest with the project owner, designer, or both.

## Brick Types, Sizes & Estimating

### Bonds

### Brick Positions In Wall

### Joints

## Brick Types, Sizes & Estimating

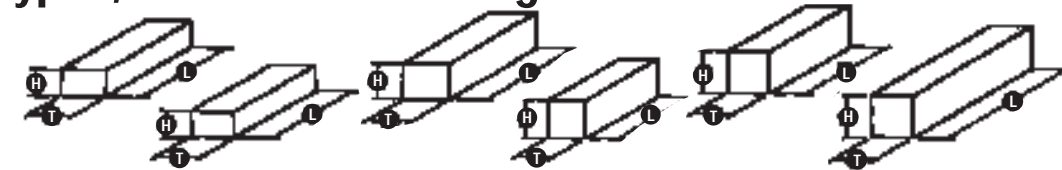

Brick Type	STANDARD T H L	MODULAR T H L	OVERSIZE T H L	QUEEN T H L	CLOSURE T H L	UTILITY T H L
Size (actual)	3 <sup>3</sup> / <sub>4</sub> " 2 <sup>1</sup> / <sub>4</sub> " 8"	3 <sup>5</sup> / <sub>8</sub> " 2 <sup>1</sup> / <sub>4</sub> " 7 <sup>5</sup> / <sub>8</sub> "	3 <sup>3</sup> / <sub>4</sub> " 2 <sup>3</sup> / <sub>4</sub> " 8"	3" 2 <sup>3</sup> / <sub>4</sub> " 8"	3 <sup>1</sup> / <sub>2</sub> " 3 <sup>1</sup> / <sub>2</sub> " 7 <sup>1</sup> / <sub>2</sub> "	3 <sup>1</sup> / <sub>2</sub> " 3 <sup>1</sup> / <sub>2</sub> " 11 <sup>1</sup> / <sub>2</sub> "
Nominal Joint Thickness	3/8"	3/8"	3/8"	3/8"	1/2"	1/2"
Units per Square Foot of Wall	6.5	6.75	5.5	5.5	4.5	3.0
Cubic Feet of Mortar per 1000 Brick (including waste)	19	19	20	16	24	30

Careful estimating is important. Correct quantities and prices will enable completion of the job without unnecessary waste and cost.

Your brick manufacturer is available to help in estimating and selecting brick sizes and styles. Call on them for their expertise and advice. *\*Typical unit sizes and dimensions may vary from manufacturer to manufacturer.*

## Bonds

Creative use of unique bond variations can add to the subtle elegance of any home or building. Through the use of these bonds and variations of the color and texture of the brick and of joint types and colors, an almost unlimited number of patterns can be developed. Familiarity with these patterns and a little creativity can insure a saleable home.

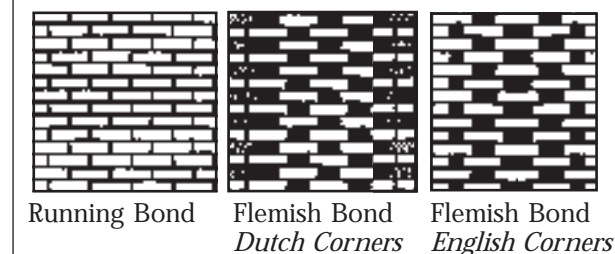

Running Bond Flemish Bond Dutch Corners Flemish Bond English Corners

## Brick Positions In Wall

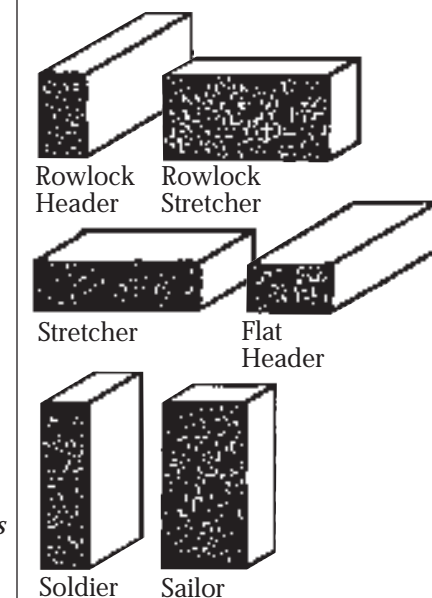

Rowlock Header Rowlock Stretcher Stretcher Flat Header Soldier Sailor

## Joints

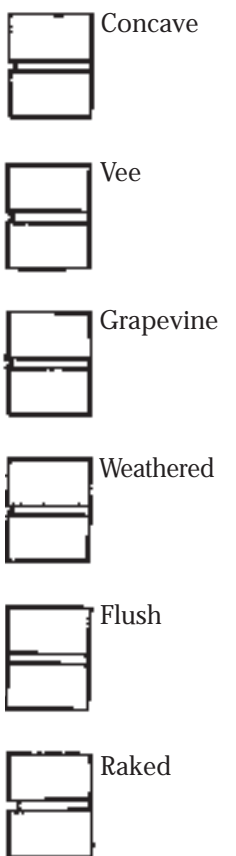

Finishing the mortar joints serves several purposes; it helps insure weather-tightness, and also influences the appearance of the wall.

Careful selection of joint finishes can substantially enhance the overall appearance of a structure.

**Wall  
Types**

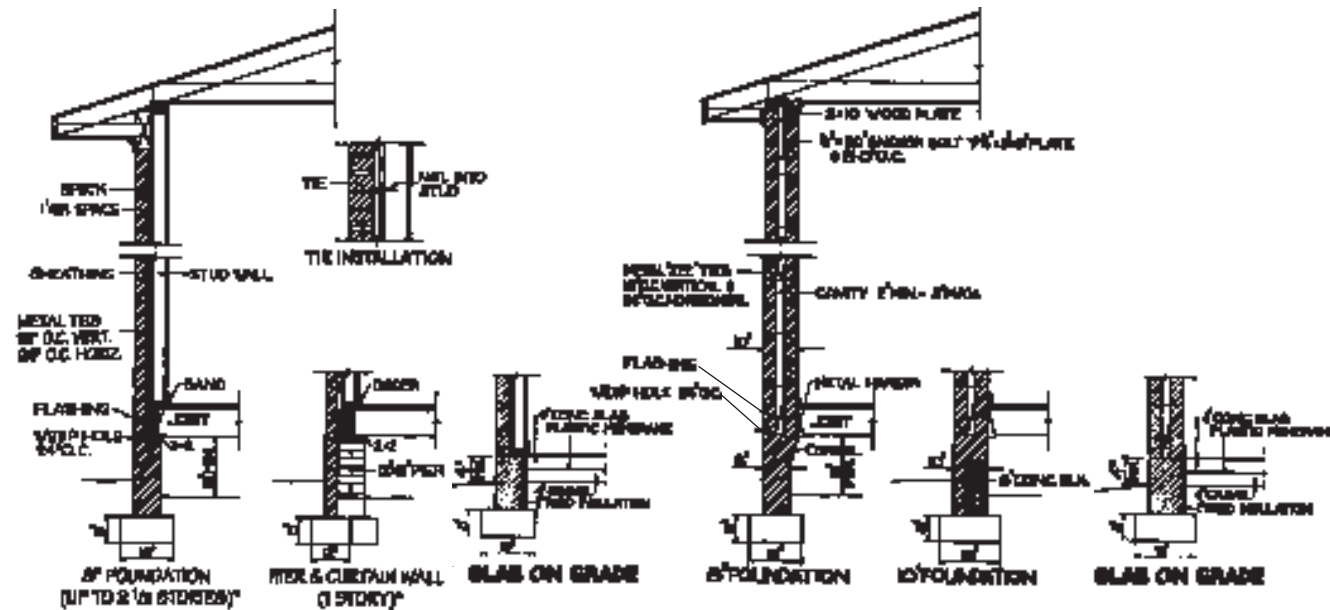

Typical Brick Veneer Wall Details

**Brick Veneer Wall**

Brick veneer walls are currently the most widely used walls for residential construction. The brickwork is a “veneer” since it is a non-loadbearing facing built after framing is complete. This is a “drainage” type wall. An air space is provided back of the brickwork to allow any penetrating water to fall to the base of the veneer where flashing and weep holes are provided to divert water back out of the wall.

Footing size and foundation anchorage should be determined per local building codes.

Foundations should extend not less than 12 inches below the finished natural grade or engineered fill and in no case less than the frost line depth.

Typical Brick Cavity Wall Details

**Brick Cavity Wall**

A cavity wall consists of two wythes of masonry separated by a continuous air space that is between two and four inches in width. The cavity wall is utilized because it is an exceptional all-weather wall. Because of its ease of insulation, it is an efficient energy saver. The cavity wall helps resist noise penetration, is fire resistant and is virtually maintenance free.

The two walls are tied together with metal ties. Spacing and type of ties can vary and should be determined on a case by case basis.

The brick cavity wall, a “drainage” type wall, is particularly impervious to moisture penetration because the air cavity (space) allows any moisture to drain to the bottom of the wall. Proper flashing and weep holes are important to drainage. Flashing directs moisture from the interior wythe to the outside of the exterior wythe. Flashing should be installed over all openings, under sills and, most importantly, at the bottom of the cavity wall just above ground level.

*For additional information you may request Tech Note 21B, “Brick Masonry Cavity Walls Detailing.”*

**Insulating Brick Walls**

**Insulating The Brick Veneer Wall**

The brick veneer wall may be insulated by use of standard insulating sheathing and fiber glass batt insulation placed between studs, giving an “R” value of approximately 14, and a “U” value of approximately 0.07.

Mass of the brick veneer and the nominal one inch air space between veneer and sheathing adds greatly to energy efficiency of the brick veneer wall.

**Insulating The Brick Cavity Wall**

One of the most important advantages of the brick cavity wall is that the cavity may be used for placing insulation within the wall.

In order to insulate the wall properly it is absolutely essential that the cavity be kept clean during construction.

Insulations that have been used in cavity walls include loose fill poured type, rigid board type and foamed-in-place type.

“R” value for a 12 inch brick and brick cavity wall insulated with poured vermiculite or a 2 inch rigid styrene board would be approximately 14, and the “U” value would be approximately 0.07.

Mass of the brickwork provides additional energy saving qualities not recognized in standard “U” value calculations.

Brick Veneer Wall

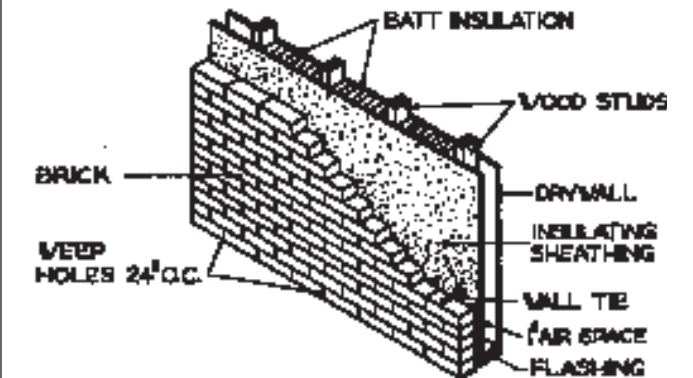

Brick Cavity Wall

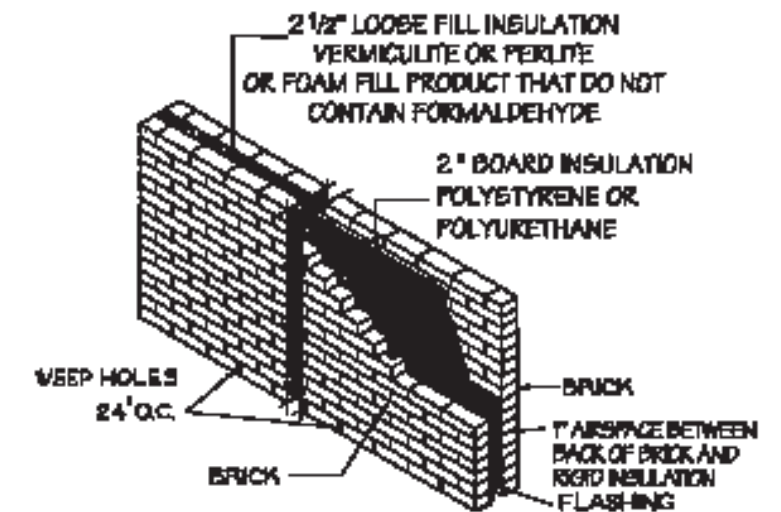

## Guide To Brick Construction

### Mortarless Interior Brick Flooring

Mortarless brick flooring may be placed on a concrete slab or on a wood flooring system as shown in the illustrations.

The size of the brick is optional, except for patterns such as basket weave and herringbone, which require brick with length dimensions exactly twice that of the width, such as 4"x8" or 3 3/4"x7 1/2", etc.

Thickness of brick used on a concrete slab may vary up to 2 1/4", but maximum thickness of 1 5/8" is recommended for wood flooring systems to reduce weight. Joist spacing of wood flooring systems should be limited to 12" o.c.

Building paper is first placed on the supporting base with edges butted rather than lapped. Two layers of 15 lb. felt are recommended. Brick are placed directly on the felt in the desired pattern. Units should be placed tightly together.

Clean, dry sand is then placed on the brick and swept into all joints. Surplus sand is swept off and sealer may be applied when floor is completely dry. Sealing is necessary as it locks sand in joints and creates an impervious floor finish.

Because sealing is so important, it is suggested that great care be given to choosing and applying a ceiling product. For specific questions on sealing concerns, contact the technical department at Brick SouthEast.

### Mortarless Interior Brick Flooring

Brick floor on wood support system

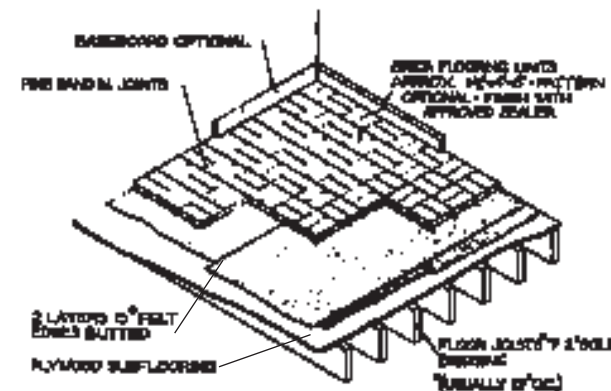

Brick floor on concrete slab

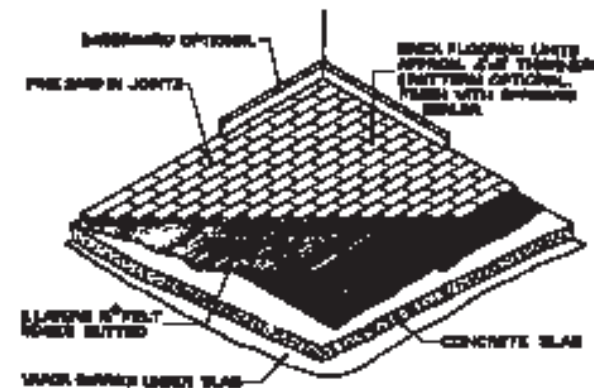

### Fireplaces

### Fireplaces

Today, brick fireplaces are considered standard in almost all homes. The need for a backup or secondary heating system has created a renewed interest in the open fireplace that has historically been the "Heart of the Home."

Today's fireplace is subjected to higher temperatures and more prolonged use than at any other time in memory. Because of increased temperatures and length of use, the home builder must ascertain if his fireplace design meets all requirements of the Building Code and insure that constant supervision be given to the carpentry and masonry crews during construction of the structure and surrounding framing. Since the safety of human life is involved, these details should not be left solely to subcontracting crews.

Also, special attention should be given to determining the type of chimney footing required. Building Codes require that concrete footings for chimneys rest on "solid ground," and/or extend down to the level of main foundation footings and that they be bonded with main footings. "Solid Ground" means firm, undisturbed soil or adequately controlled fill.

Size of the fireplace should be in proportion to the room size. The U.S. Department of Agriculture has determined that a fireplace 30 to 36 inch wide is generally suitable for a room having 300 square feet of floor space.

A fresh air supply substantially increases the efficiency of a fireplace by reducing the amount of heated air taken from the living space. Details of the adjustable fresh air damper and ductwork are shown.

The fireplace builder should be cautioned to leave room in masonry work for expansion of metal lintels, dampers and firebrick linings in order to avoid masonry cracks.

For complete details of construction, refer to Brick SouthEast's publications, "Good Practice for Construction of Brick Fireplace" and "Fireplaces."

Section

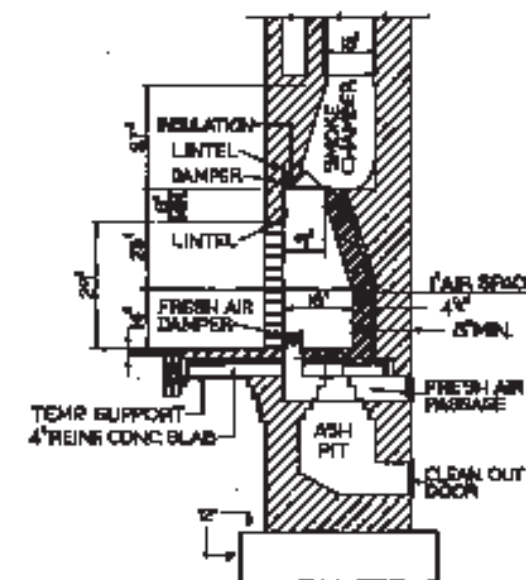

Plan &  
Front Elevation

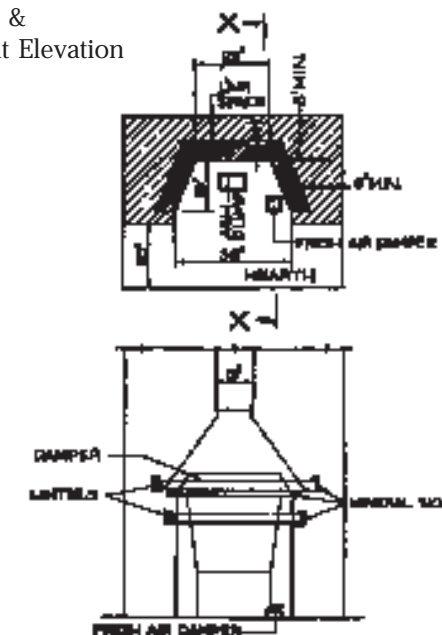

**Guide  
To Brick  
Construction**

*Arches*

**Arches**

The arch provides a method of spanning masonry wall openings that not only has structural advantages over lintels and beams, but gives designers a method of expressing various architectural effects and styles.

Arches are constructed with the aid of temporary forming or centering which must carry dead loads until the arch has gained sufficient strength to support itself and other superimposed loads. Generally, forms should remain in place a minimum of ten days after completion of all masonry work to be supported by the arch. To help simplify construction of flat or jack arches, a steel angle (lintel) is sometimes used as a permanent form in brick veneer construction.

Complete filling of all mortar joints is especially important in arch construction since joints are vital in maintaining the compression ring or

wedging effect of the arch. Any movement caused by the slightest sliding, settlement or rotation of abutments or supports or the arch itself may result in failure of the arch.

Orders for brick arches should be placed with the brick manufacturer at the inception of the job, and detailed drawings, preferable full drawings of a half arch, should accompany the order. The following information should be on drawings:

1. Masonry Opening Dimensions
2. Mortar Joint Thickness
3. Number of Courses High
4. Bonding of Arch (One, Two, Three Piece)
5. Skewback Angle
6. Type and Texture of Brick used
7. Radius of Radiuses, if applicable

For design information on brick arches, see Brick Institute of America "Technical Notes," Number 31 series.

Jack



Segmental



Details

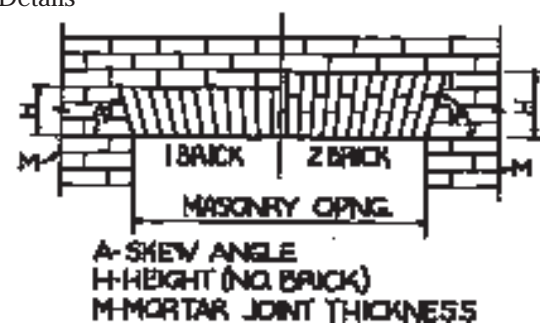

Semicircular

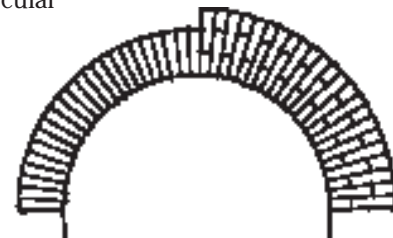

Elliptical



Arch Form



*Quoin Corners  
Water Table*

**Quoin Corners**

Quoins are special ornamental projections executed in brickwork to mark corners of buildings and to create an overall appearance of strength, grandeur, and solidity.

When constructing quoins, brick is laid in the standard method with a two inch air space allowed between the brick and the sheathing rather than the normal one inch of space. It is important that an adequate number of ties be used.

This relatively simple masonry technique is a sign of elegance that will be a lasting reminder of the quality of the builder's work

Quoin Elevations;  
Front & Side

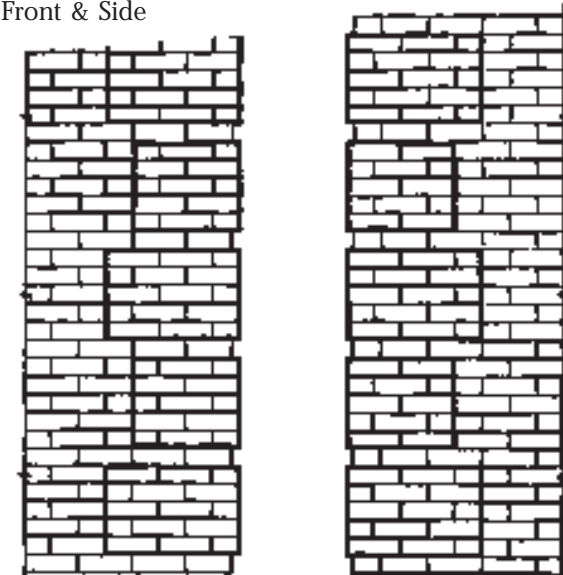

**Water Table**

A brick water table can add that touch of early American architectural detail to any colonial style house.

Your brick representative can help in selecting the most appropriate factory-made brick water table design for a particular situation.

Typical Water Table:  
Brick Veneer Wall

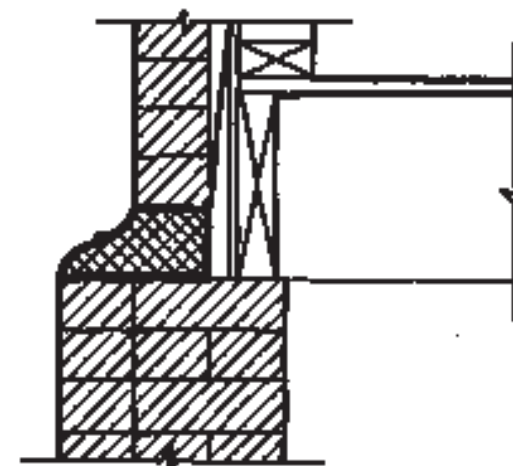

Quoins:  
Perspective  
& Plan

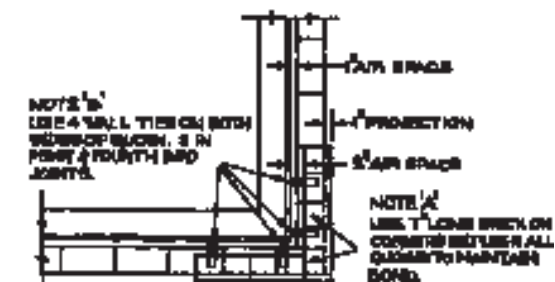
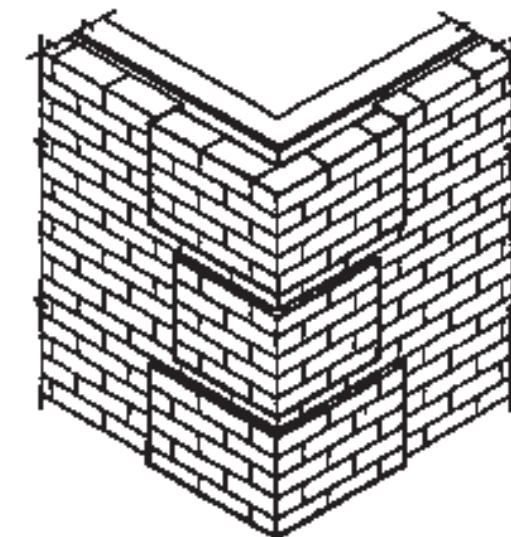

## Guide To Brick Construction

### Steps

Brick steps can be the final visual touch to provide handsome curb appeal for any home. Since steps are normally exposed to severe weathering, quality materials and good workmanship are essential for good construction and performance.

All brick steps should be placed on concrete footings. Concrete should be 2500 PSI (28 days) placed in an area excavated to solid earth with a 12" minimum depth below finished grade. All footings should be a minimum of 8" deep and have a 4" projection past steps except where they abut an adjoining wall. In situations of questionable soil conditions, reinforcing steel should be used. All masonry used in steps should be laid with type "S" mortar.

Rowlock tread steps having 7" risers and 12" treads should be built using factory-made corners which are available from all brick manufacturers. For specific tread and riser dimensions, consult with your local code official.

Ogee Rowlock Step Tread  
*Special units add a  
designer appearance.*

*Check with your  
brick manufacturer  
for availability.*

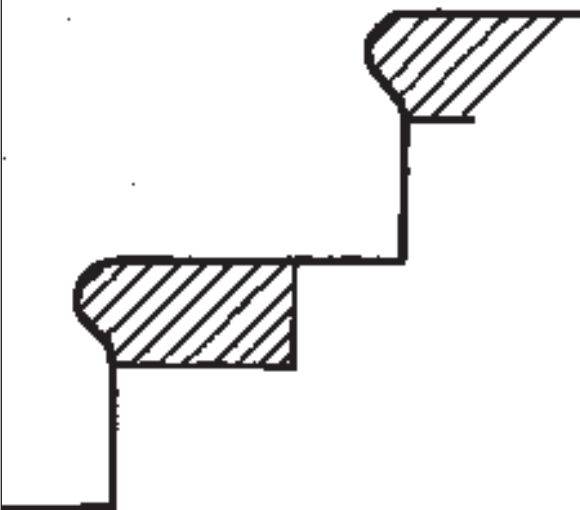

### Steps

Rowlock Tread/7" Riser  
*Use 8"x8"x4" factory made corners*

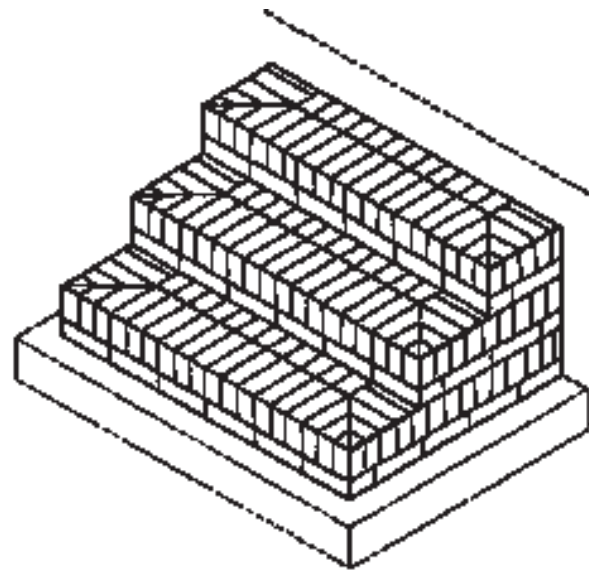

End Elevation and  
Step Elevation  
*Respectively*

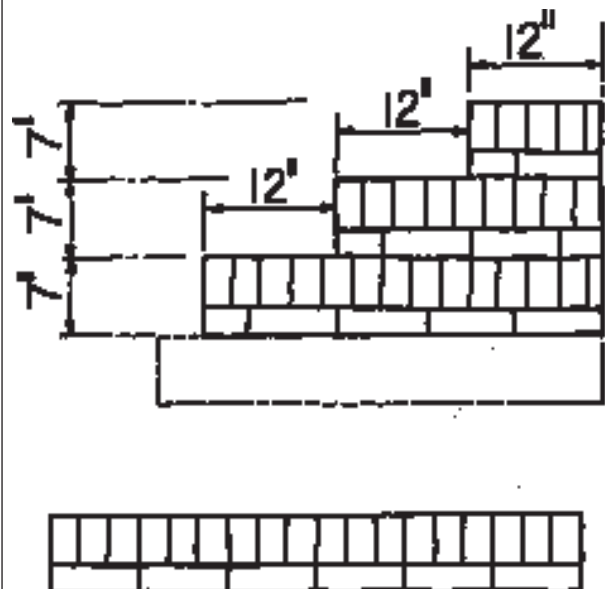

### Exterior Paving

### Exterior Paving

Brick walkways, patios and driveways are more popular now than ever before. Homebuilders are finding brick paving a "must" in today's highly competitive market. Brick paving is an easy way of adding value to the property you are putting on the market.

Mortarless paving is much cheaper to build than mortared paving and, if built properly, can provide the same enduring qualities of conventional paving systems and materials.

The most important consideration for mortarless paving is a good base. Solidly compacted earth and other base materials will generally eliminate settlement problems. Good drainage of the general area where mortarless paving is to be installed will help maintain a stable base and help prevent growth of algae on paving units.

Providing good edge retention of mortarless paving is essential, and, of course, specifying weather-resistant brick paving units is important to a quality installation.

### A few patterns

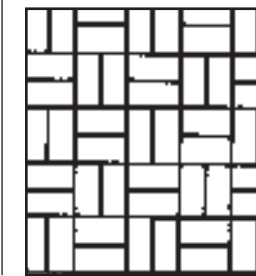
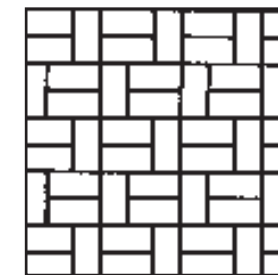
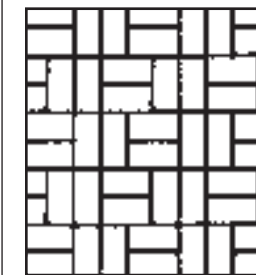
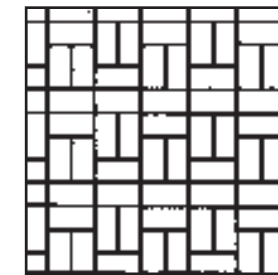
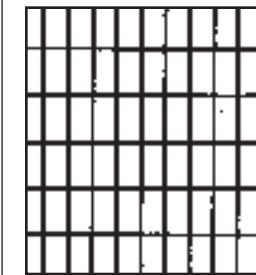
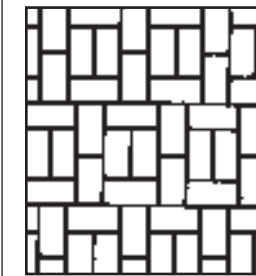
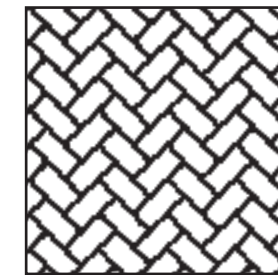
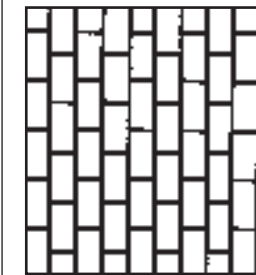

## Guide To Brick Construction

### Driveways

## Driveways

### Specifications

Mortarless brick paving should conform to the alignment and grade as shown on the plans. The subgrade (earth) should be well compacted with all organic material and soft soil removed and replaced with an approved soil. Paving brick should conform to ASTM C902, Class SX. Color and dimensions should be approved from a sample. Mortarless brick paving may be installed by semi-skilled labor.

### Installation

1. Install a row of curb brick on one side of the driveway, setting units to the required height. Use mortar behind and under curb units as needed for support. Set a temporary form on the opposite side of driveway to proper grade, 2-3 inches outside of the location of curb brick installation.
2. A base course should be placed and compacted. The base material should be of Aggregate Base Course (ABC) conforming to DOT specifications. The aggregate should be placed on an approved subgrade between the curb brick row and the temporary form. The aggregate can be compacted with a vibratory plate compactor or by hand and should have a slight crown upon completion. When compaction is complete the base course should be smooth, hard, dense, unyielding and well bonded.

3. Place a 1/2" to 1" layer of sand or stone screenings on the base course, using screed to spread uniformly over the entire area. Moisten and compact by hand or a mechanical device. Rescreed this layer as required to bring surface to the exact grade.
4. Begin laying pavers along previously installed rows of curb brick, using specified bonding pattern and continuing until all paving is laid. Normally, paving units are placed tightly together leaving no space between individual pavers. However, if units have very smooth uniform edges or if pavers are very uniform in size, 1/16" should be left between units to allow a space for sand to surround each unit.
5. Remove the temporary form. Install final row of curb brick tightly along the outer row of pavers by removing groups of 5 or 6 pavers from the outer row and excavating a small trench for the curb brick in this area. Place the curb brick in this trench, backfill and tamp on both sides and use mortar behind and under units as needed for support. Set curb units to required grade. Replace and smooth screenings and replace paving brick.
6. Scatter stone screenings or sand over entire surface and sweep into cracks.

### Perspective

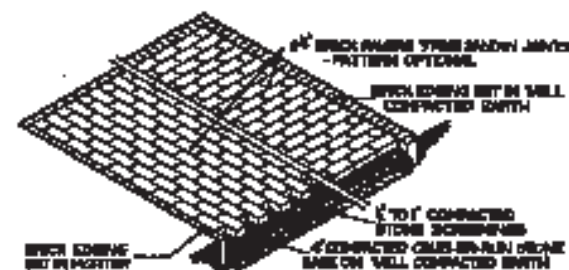

### Sections



### Walkways & Patios

## Walkways & Patios

### Specifications

Mortarless brick paving should conform to the grade as shown on plans. The subgrade (earth) should be well compacted with all organic material and soft soil removed and replaced with an approved soil. The paving brick should conform to ASTM C902, Class SX. Color and dimensions should be approved from sample.

### Installation

1. Install a row of edge brick on one side of the walk to the required alignment and grade. Set a temporary form on the other side of the walk to the proper grade, 2"-3" outside of edge brick location.
2. Complete grading as shown in sketch below and place stone screenings or sand between the forms to approximate required depth using the screed to spread uniformly over the area. Moisten screenings or sand and compact by hand or mechanical equipment. Rescreed screenings or sand, as required, to smooth base and bring surface to the required grade.
3. Start laying pavers along the previously installed row of edge brick, using specified bonding pattern, and continue this until all pavers are laid.

Normally, paving units are placed tightly together, leaving no space between individual pavers. However, if the units have very smooth uniform edges or if pavers are very uniform in size, 1/16" should be left between units to allow a space for sand to surround each unit.

4. Remove the temporary form. Install final row of edge brick tightly along outer row of pavers by removing groups of 5 or 6 pavers from outer row and excavating a small trench for edge brick in this area. Place edge brick in this trench, backfill and tamp on both sides, replenish and smooth the screenings or sand and replace paving brick.
5. Scatter stone screenings or sand over entire surface and sweep into the cracks.

*For additional information see "Brick Paver Paths, Patios, & More" available from Brick SouthEast.*

### Perspective

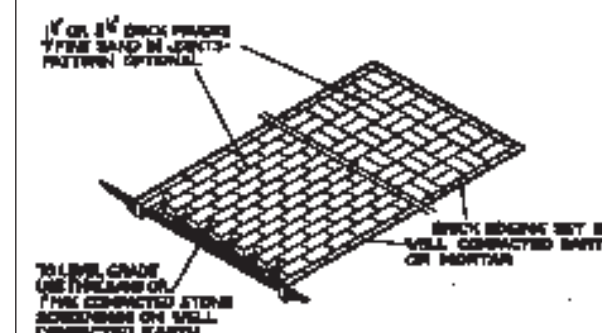

### Sections

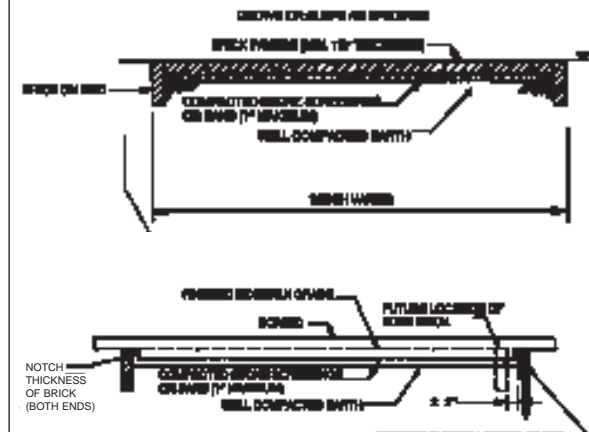

## Guide To Brick Construction

### Brick Cleaning

## Brick Cleaning

### Four Simple Steps For Better Brick Cleaning

Often forgotten, brick cleaning is actually one of the most important parts of new home construction so far as the Home Buyer is concerned. Why not give brick cleaning the same concern given other "Final Appearance" items?

Brick cleaning is not difficult – if properly done.

First thing to do is to ask the brick manufacturer for recommendation on cleaning the particular brick. If a decision is made to use an acid cleaning system, then a particular acid product should be agreed upon.

Before applying acid solution, larger mortar particles should be removed by use of hand tools, reducing unwanted mortar deposits to paper-thin smears.

Next, apply plenty of water to the masonry, enough to satisfy thirst of the wall and keep water standing on surface of masonry.

Apply acid solutions, mixed according to instruction on container. Scrape any remaining mortar particles, reapply solution and rinse wall thoroughly, flushing off all acid and dissolved mortar particles.

Care should be taken to protect nearby painted surfaces, glass, metal, etc. Test areas should be treated and necessary approval secured before continuing.

High pressure water systems may be used to rinse masonry, but may not be used to apply acids. Test areas should be rinsed and necessary approval secured before continuing with high pressure water systems.

Sandblast cleaning is an acceptable method for cleaning new masonry. As with all cleaning systems, test sections should be cleaned and necessary approval secured before continuing sandblasting.

For complete information on the cleaning systems described above and for information on specialty cleaning see the Brick Association publication "Cleaning New Brickwork."\*

\*The publication can be accessed at [www.gobricksoutheast.com](http://www.gobricksoutheast.com) (professional segment).

1. Remove large particles of mortar with hand tools before washing the wall.



2. Thoroughly pre-wet with water before cleaning. Plenty of water is the secret of good masonry cleaning. Be sure the brickwork below the area being cleaned is thoroughly soaked with water so dissolved mortar from above won't be drawn into face of the brick below.



3. Apply cleaning solution with brush, mixed as directed on container. Follow printed instructions as to length of time solution should remain on wall. Scrape as needed, and continue brushing.



4. Rinse thoroughly with water immediately. Remember, the secret of good masonry cleaning is using plenty of water.



### Mailboxes

## Mailboxes

A brick mailbox is a simple, but unique way to dress up your front yard and add that final touch of class to your home. It is a simple, do-it-yourself project that can be done by the weekend mason in the family.

Pictured here are just a few of the many designs available. Use one of these or design your own. Brick mailboxes let you be as creative as you like.





## Garden Walls

**English Bond**  
with pattern formed  
by headers alternately  
projected and  
omitted

**Flemish Bond**  
with open pattern  
of crosses

**Flemish Bond**  
with open header  
pattern

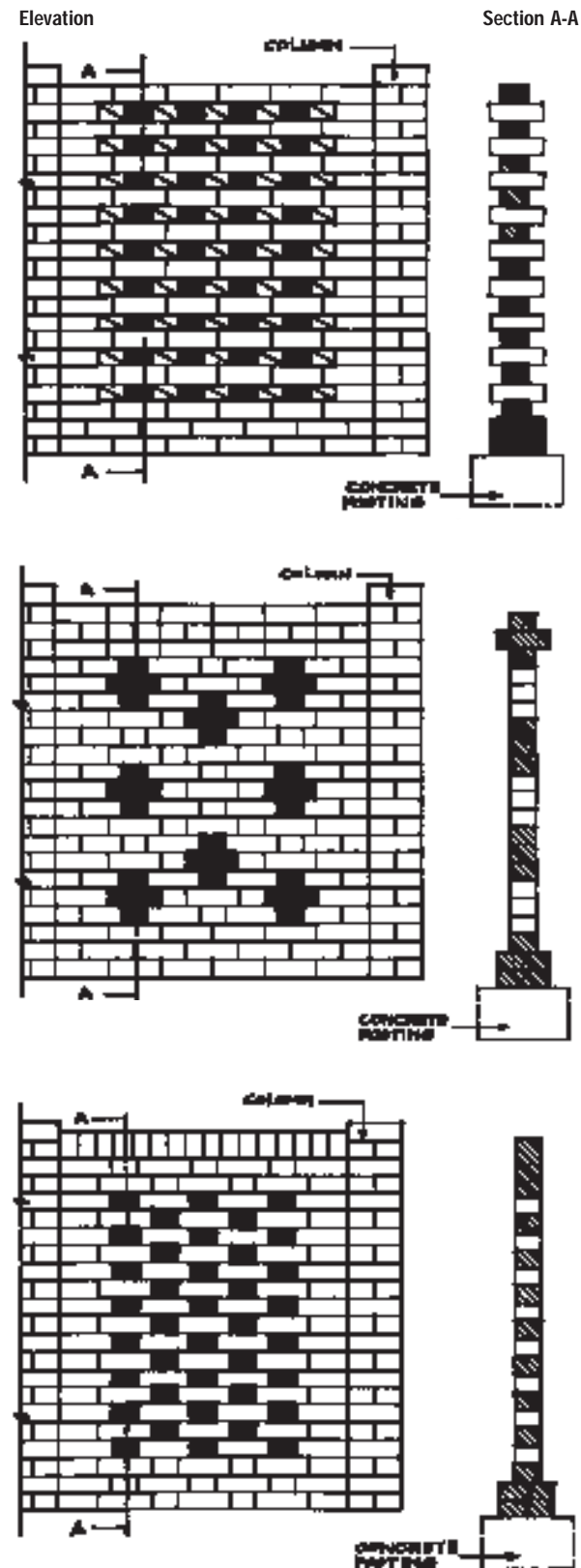

## Retaining Walls

*Note: For back fill up to 3 feet  
above footing*

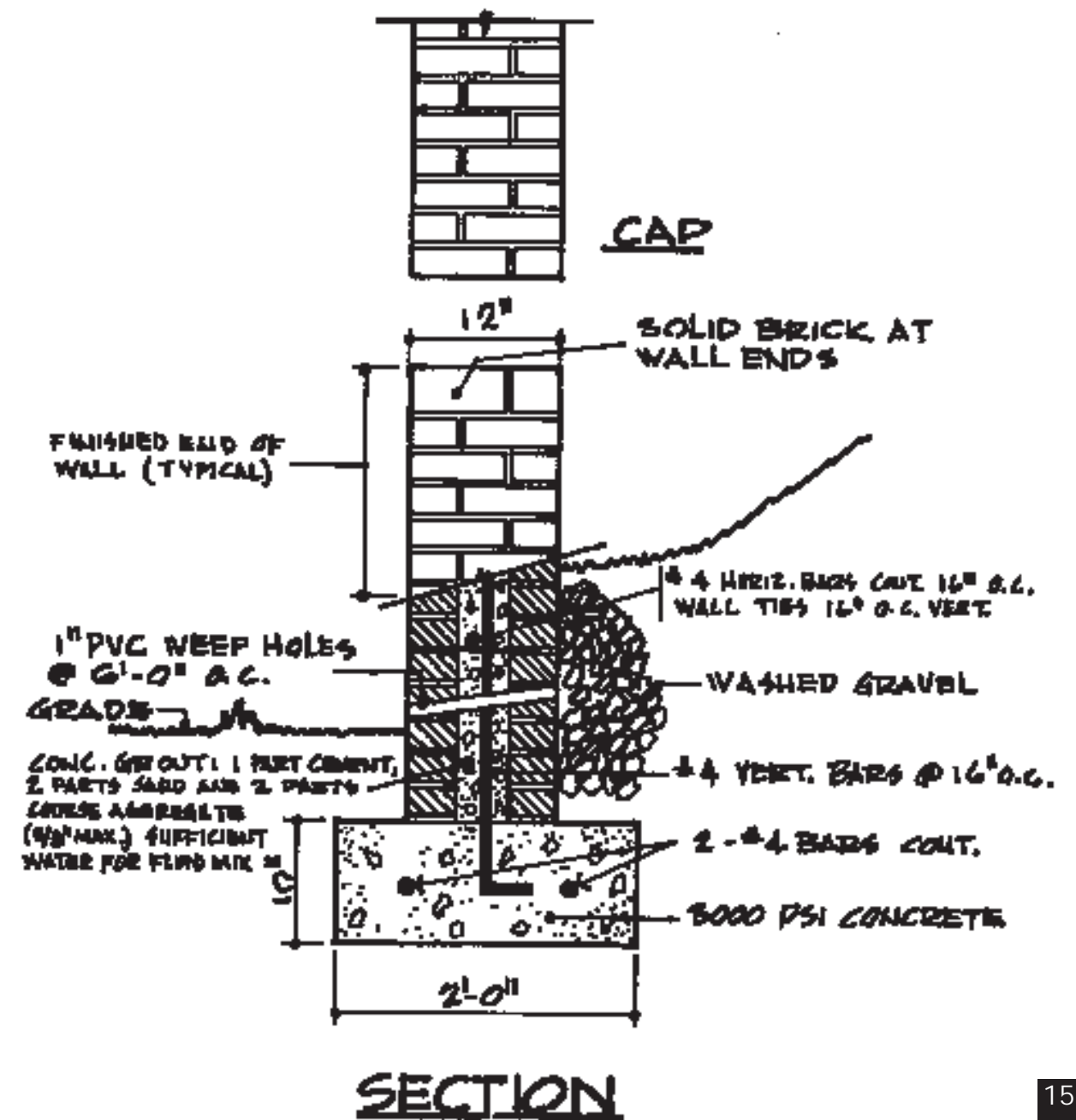

**Guide  
To Brick  
Construction**

*Exterior Remodeling  
with Brick*

**Exterior Remodeling  
with Brick**

**Brick Veneer**

An experienced builder can transform old buildings into new ones with brick veneer. Brick veneer is applied as in regular new brick veneer construction. The brick are secured with metal veneer ties attached to the existing wall and spaced no further

apart than 16" vertically, and 24" horizontally.

**Footings**

If the existing footing projects at least 5", this is sufficient to start the new brick veneer. Otherwise, an additional concrete footing approximately 8" deep (minimum) should be installed. *Note: Engineering analysis required for all details.*

**Details**

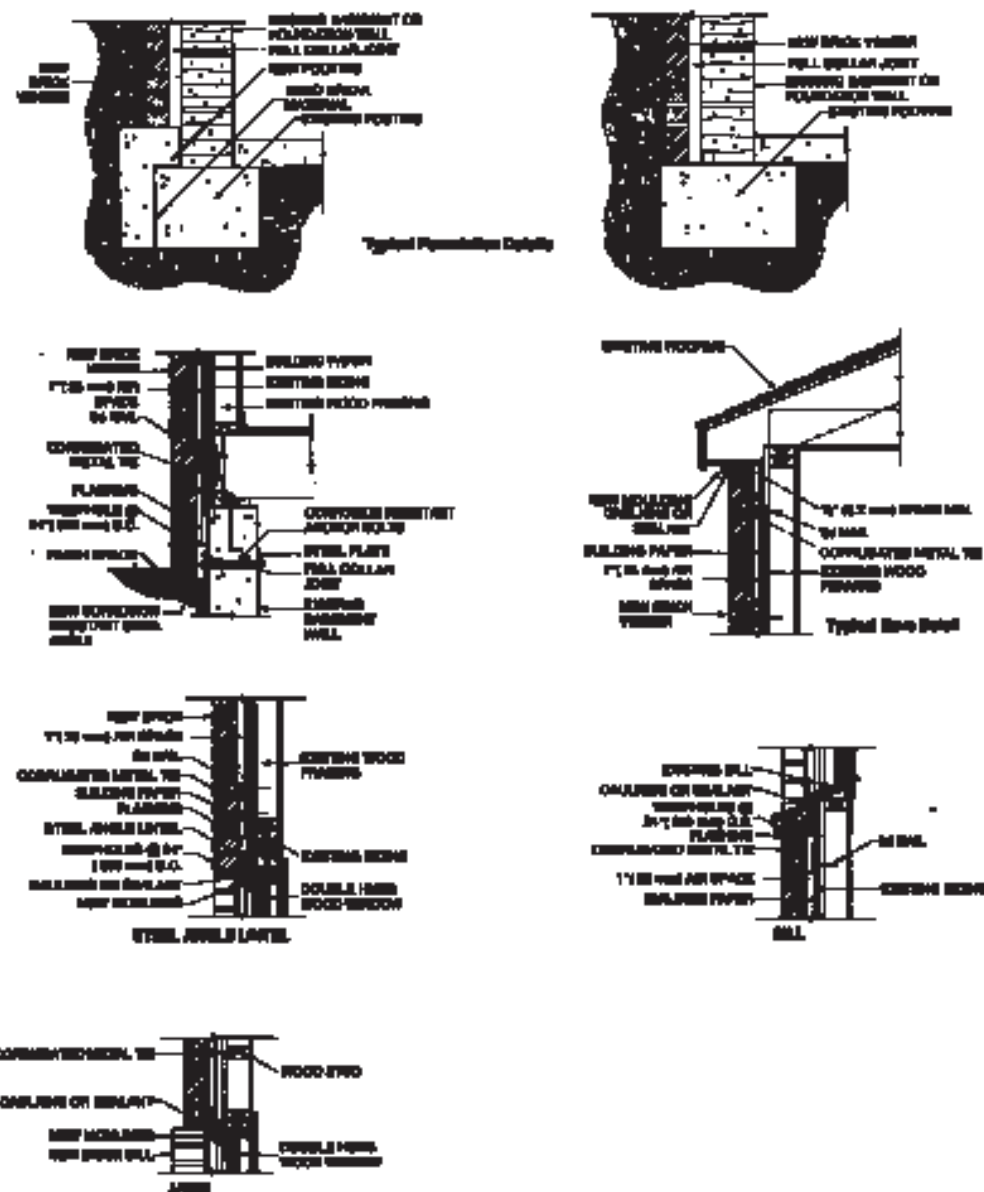

**Brick Does  
Not Leak**

**Brick Does Not Leak**

Occasionally one may encounter the problem of a "leaky wall." Experience shows, however, the cause of the problem is not the brick, but improper construction technique.

The following improper conditions may contribute to the "leaky wall" problem and should be avoided:

- Poor bond between brick and mortar*
- Use of "raked" or "scratched" joints*
- Use of poor quality mortar*
- Excessive mortar droppings in air space or cavity*
- Poor foundation walls*

In spite of the need to supervise all aspects of construction, it is obvious one cannot be everywhere and do everything. For this reason, we offer this information to acquaint you with some basic techniques to help prevent these problems. *It will be helpful if you keep a copy on the job site.*

**Head Joint Construction**

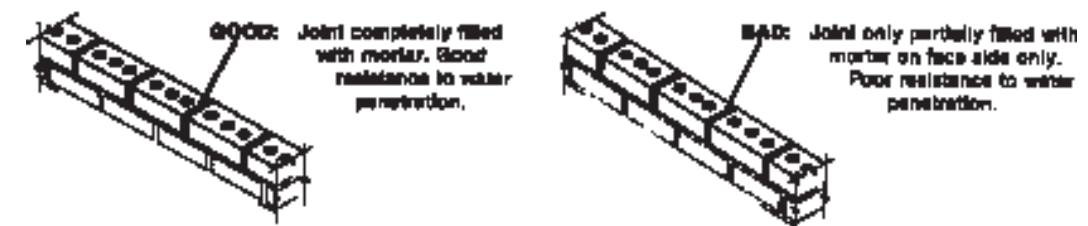

**Brick Veneer on Wood Frame**

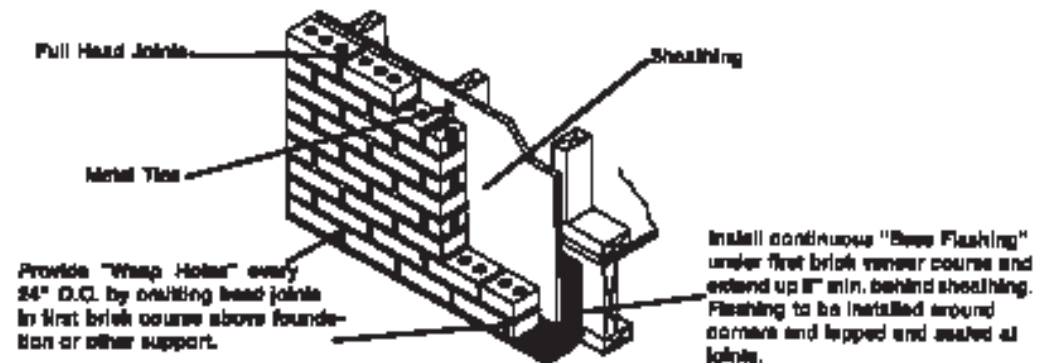

**Solid (Composite) Walls**

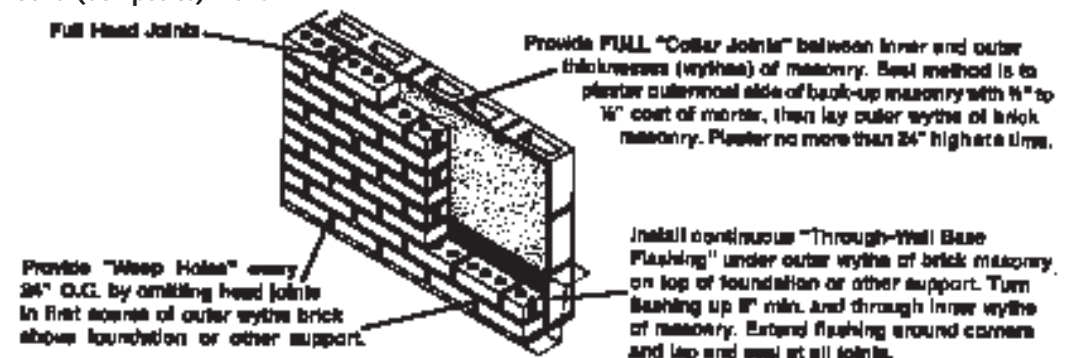

**Guide  
To Brick  
Construction**

*Cold Weather Masonry  
Construction & Protection  
Recommendations*

**Cold Weather Masonry  
Construction & Protection  
Recommendations\***

Cold weather masonry construction and its quality control require some additional attention to construction practices and protection. Attention should be directed to the following details as well as those normally attended.

1. The cold weather construction and protection recommendation of this recommended practice should be closely followed.
2. Construction materials should be received, stored, and protected in ways that prevent water from entering the materials.
3. If climactic condition warrant, temperatures of construction materials should be measured – frozen sand and wet masonry units must be thawed. Masonry units below 20°F must be heated above 20°F without overheating.

\*This brochure contains general cold weather construction recommendations. Code specific recommendations for hot and cold weather construction can be found in the Masonry Standards Joint Committee document.

4. Sufficient mortar ingredients should be heated to produce mortar temperatures between 40°F and 120°F. Every effort should be made to produce consecutive batches of mortar with the same temperatures falling within this range. The mortar temperature after mixing and before use should be above 40°F, maintainable either by auxiliary heaters under the mortar board or by more frequent mixing of mortar batches. Heated mortar on mortar boards should not become excessively hot (greater than 120°F).
5. During below-normal temperatures, masonry should be placed only on sound unfrozen foundations. Masonry should never be placed on a snow or ice-covered surface, because of the danger of movement when the base thaws and the possibility of very little bond being developed between the mortar and the supporting surface.
6. At the end of the day, the top surface of all masonry should be protected to prevent moisture, as rain, snow or sleet, from entering the masonry. This protection must cover the top surface and should extend a minimum of 2 feet down all sides of the masonry.

Mean Daily Temperature*	Construction Requirement	Protection Requirement
Above 40°F	Normal masonry procedures.	Cover walls with plastic or canvas at end of work day to prevent water entering masonry.
40°F–32°F	Heat mixing water to produce mortar temperatures between 40°F–120°F.	Cover walls and materials for a minimum of 24 hours after construction to prevent wetting and freezing. Covers should be plastic or canvas.
32°F–25°F	Heat mixing water & sand to produce mortar temperatures between 40°F–120°F	With wind velocities over 15mph provide wind-breaks during the work day and cover walls and materials at the end of the work day to prevent wetting and freezing. Maintain masonry above freezing for 24 hours using auxiliary heat or insulated blankets.
25°F–20°F	Mortar on boards should be maintained above 40°F.	
20°F– 0°F	Heat mixing water & sand to produce mortar temperatures between 40°F–120°F	Provide enclosures and supply sufficient heat to maintain masonry enclosure above 32°F for 24 hours.

\*For questions regarding specific temperature concerns, contact the Technical Department of Brick SouthEast.

*Alternate Method for  
Support of Brick Veneer  
above Garage Door  
Openings*

**Alternate Method for  
Support of Brick Veneer  
above Garage Door  
Openings**

Typically garage door openings over 10 feet are required to be designed by an engineer. However, some officials recognize an alternate method of support that incorporates the concept of reinforcing the brick veneer. This technique allows the use of ladder wire joint reinforcing in the first few horizontal mortar joints above the openings as described by the diagram below. We recommend presenting this alternate method to your local official for approval in advance of actual construction.

**Construction Considerations:**

1. The maximum openings allowed by this method is 18 feet 3 inches with a minimum of 1 foot 6 inches of brick required on either side of the opening.
2. A maximum height of 5 feet of brick may be supported above the opening provided there is

a minimum of 13 inches of veneer above the opening edges (*approximately 5 brick courses*).

3. A maximum height of 12 feet of brick may be supported above the opening provided there is a minimum of 2 feet of veneer above the opening edges (*approximately 9 brick courses*).
4. A maximum height of 35 feet of brick may be supported above the opening provided there is a minimum of 5 feet of veneer above the opening edges (*approximately 22 brick courses*).
5. Care must be taken with the placement of additional openings (i.e. windows) above the garage opening. If the height of veneer is less than 3 feet no openings should be placed. For veneer heights above 3 feet the depth of openings should be limited to 1/2 the height of the veneer and they must be placed within 12 inches of the bottom and 6 inches from the top of the veneer.
6. A 5"x 3 1/2"x 5/16" angle should be used to facilitate installation and should be shored for at least 7 days after installation.

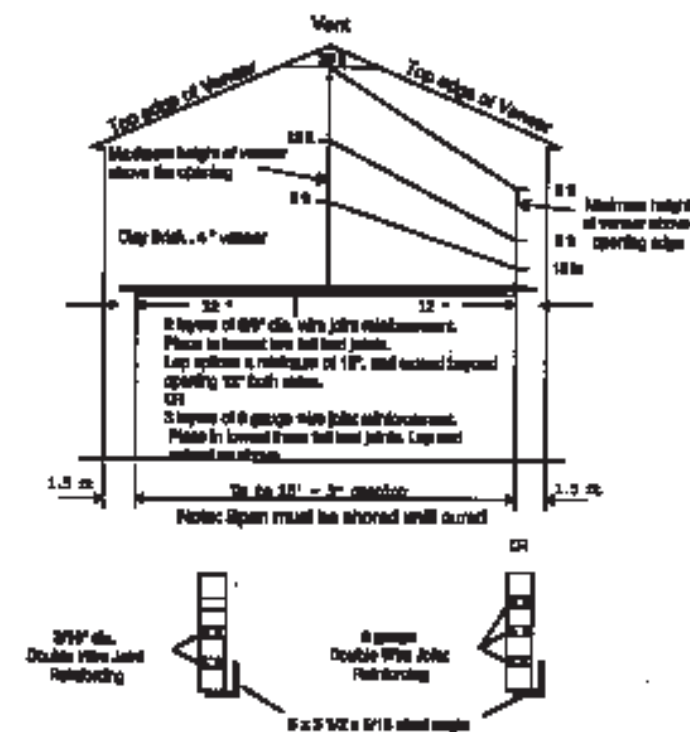



[www.gobricksoutheast.com](http://www.gobricksoutheast.com)

**800.62.BRICK**  
Suite 800  
8420 University Executive Park  
Charlotte, NC  
28262

**888.37.BRICK**  
Suite A  
1810 Overlake Drive  
Conyers, GA  
30013

*Boral Bricks, Inc.  
Carolina Ceramics Brick Co.  
Cherokee Brick & Tile  
Columbus Brick Co.  
Cunningham Brick Co.  
General Shale Brick  
Hanson Brick  
Henry Brick Co.  
Jenkins Brick Co.  
Lee Brick & Tile Co.  
Nash Brick Co.  
New London Brick Works  
Old Carolina Brick Co.  
Palmetto Brick Co.  
Pine Hall Brick Co., Inc.  
Statesville Brick Co.  
Taylor Clay Products Co.  
Triangle Brick Co.*