

**SHOP  
AWARENESS  
BRIEFING**

## WHY AN AWARENESS BRIEFING?

- o TO EXPLAIN PROBLEMS (WHAT AND WHY) THAT OCCUR WHEN PARTS ARE IMPROPERLY TRIMMED, SHIMMED, CLAMPED, ETC.
  
- o PROVIDE SHOP PERSONNEL BACKGROUND FOR TRIM REWORK THAT AFFECTS AIRCRAFT STRENGTH AND DURABILITY (LIFE)

## GROUND RULES

- \* PRESENTATION HAS 5 SECTIONS
  - \* INTRODUCTION
  - \* GAPS & SHIMMING
  - \* TRIMMING
  - \* FASTENERS
  - \* TRIM EMPOWERMENT
  
- \* HOLD QUESTIONS UNTIL THE END OF EACH SECTION (IF TIME DOES NOT PERMIT YOUR QUESTION TO BE ANSWERED, CONTACT PERSONS LISTED IN HANDOUT OR YOUR LIAISON ENGINEER)
  
- \* 5 MIN BREAK HALFWAY THROUGH BRIEFING
  
- \* MANUFACTURING PERSONNEL WILL BE ALLOWED TO TAKE NORMAL 10 MIN BREAK AFTER THE BRIEFING

AWARENESS BRIEFING

## GROUND RULES

- \* THIS BRIEFING DOES NOT GIVE ANY AUTHORITY TO PERFORM REWORK.
- \* THE ENGINEERING DRAWINGS, SPECIFICATIONS & ENGINEERING DISPOSITIONS ARE STILL THE AUTHORIZING DOCUMENTS.

## WHY AN AWARENESS BRIEFING?

- \* VISITS TO CUSTOMER BASES AND FIELD SERVICE REPORTS INDICATE STRUCTURAL FAILURES OCCUR FREQUENTLY.
- \* THESE FAILURES REQUIRE REWORK AND GROUND TIME TO RETURN THE AIRCRAFT TO FLIGHT STATUS.
- \* THESE FAILURES CAN BE PRIMARILY ATTRIBUTED TO PROBLEMS ENGINEERED AND MANUFACTURED INTO THE AIRPLANE.

## **WHY A BRIEFING?**

**TO PROVIDE YOU (MANUFACTURING) AN AWARENESS OF WHAT IS  
REQUIRED TO KEEP THE AIRPLANE PERFORMING AS ADVERTISED  
FOR YEARS TO COME.**

**AWARENESS BRIEFING**

**MOST PROBLEMS TAKE TIME TO SHOW UP. IT MAY NOT  
BE APPARENT IN THE SHOP, BUT ONCE THE PLANE  
STARTS FLYING - WATCH OUT!**

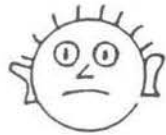
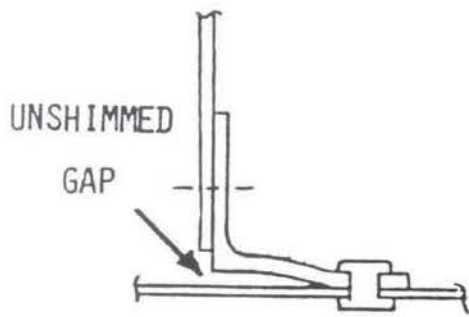

WHEN INSTALLED

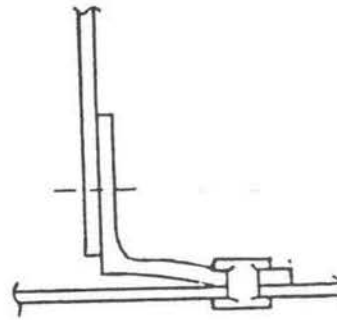

WHEN THE PLANE FLIES

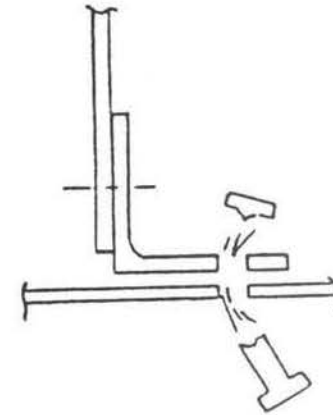

OOPS!

**AWARENESS BRIEFING**

## DEFINITIONS

SEVERAL TERMS WILL BE UTILIZED THROUGHOUT THESE BRIEFINGS AND NEED TO BE UNDERSTOOD.

- o LOAD (TENSION , COMPRESSION)
- o STRESS
- o FATIGUE
- o STRESS RISER



# BASIC TYPES OF LOADING

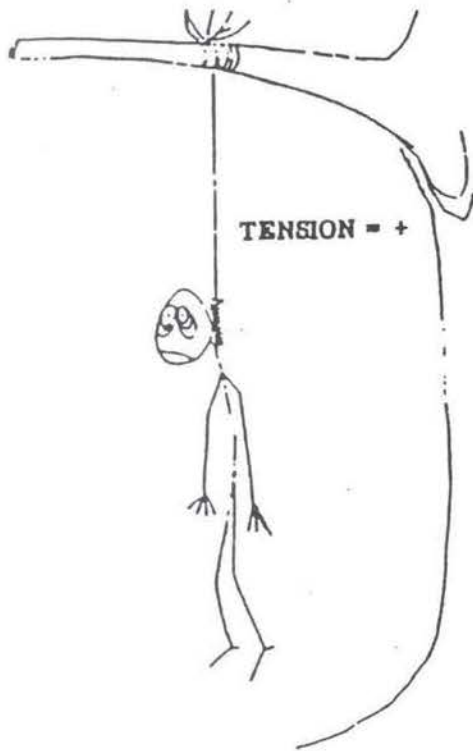

# STRESS

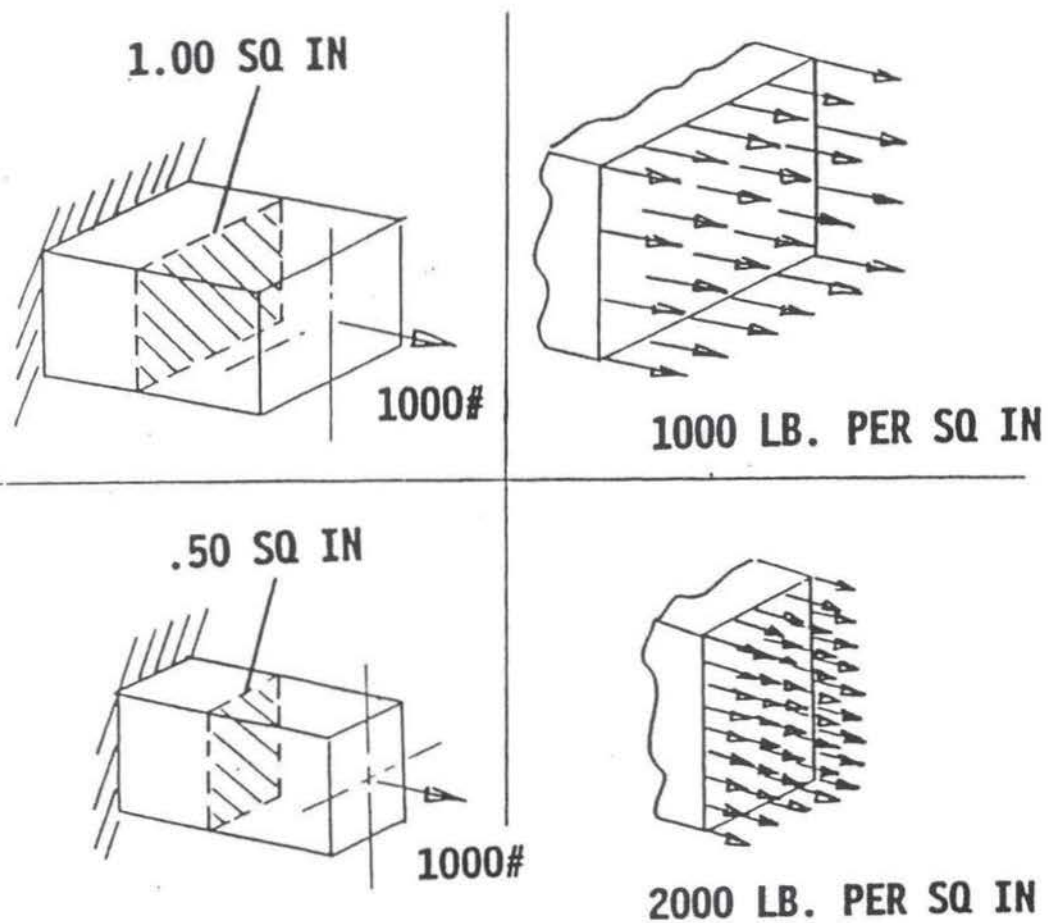

# FATIGUE

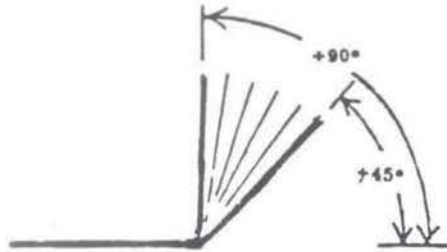

70 CYCLES  
45-to 90-DEGREE BENDING

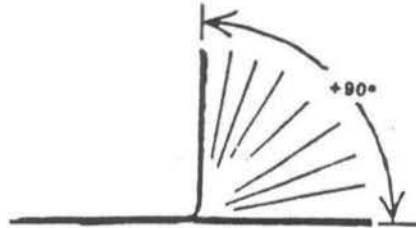

15 CYCLES  
0 to 90-DEGREE BENDING

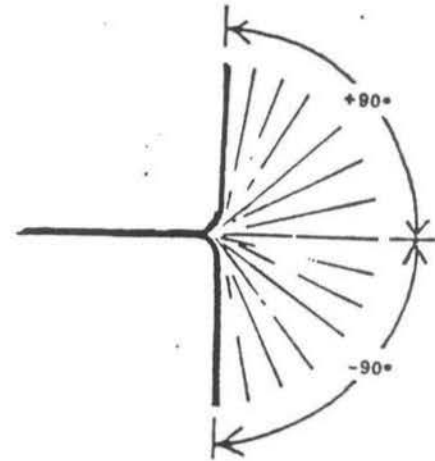

5 CYCLES  
90-DEGREE REVERSE BENDING

**A galvanized 14-gage wire**

**AWARENESS BRIEFING**

# STRESS RISERS

NICKS, GOUGES, UNDERCUTS, HOLES, SHARP EDGES, ETC.

SIMILAR TO AN OBSTRUCTION IN A STREAM

ROCK IN A STREAM

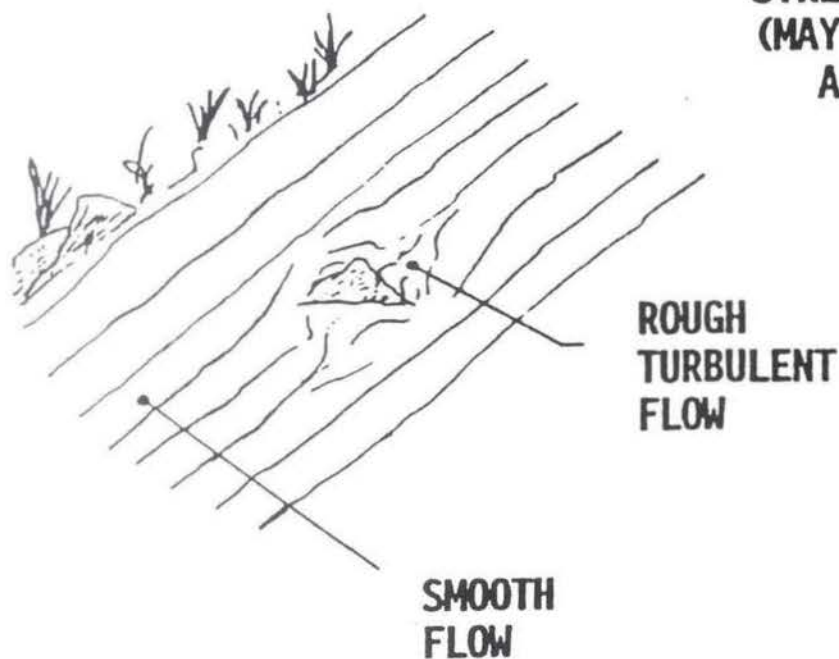

STRUCTURAL PART WITH AN UNDERCUT

STRESS RISER  
(MAY DEVELOP INTO  
A CRACK)

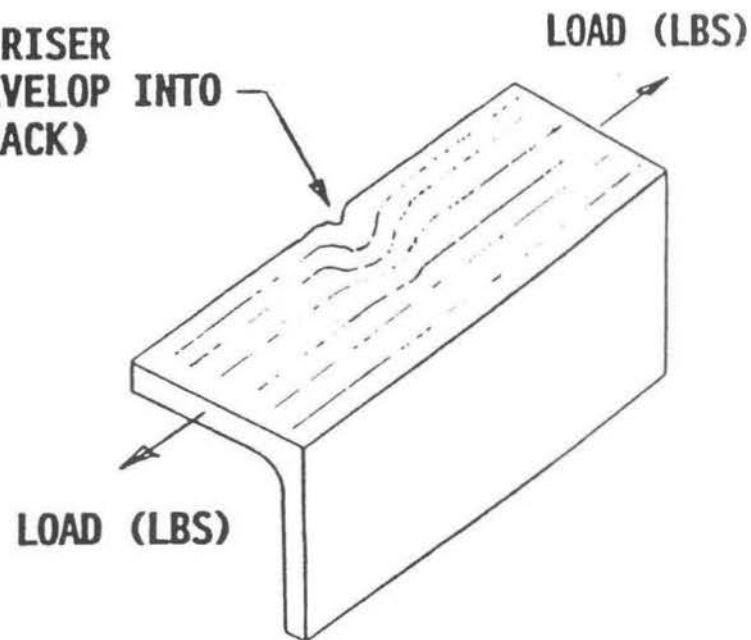

## GAPS

- o CLAMPING
- o SHIMMING

AWARENESS BRIEFING

AN IDEAL AIRPLANE HAS NO GAPS

(ALL COMPONENTS ARE NOMINAL AND FIT TOGETHER AS INTENDED)

IN THE REAL WORLD:

TOLERANCE BUILD-UP ON STRUCTURAL PARTS, PARTS NOT MADE TO B/P,  
AND B/P ERRORS ALL LEAD TO GAPS.

TYPICAL DIMENSION =  $.060'' \pm \begin{matrix} .020 \\ .010 \end{matrix}$  INCHES

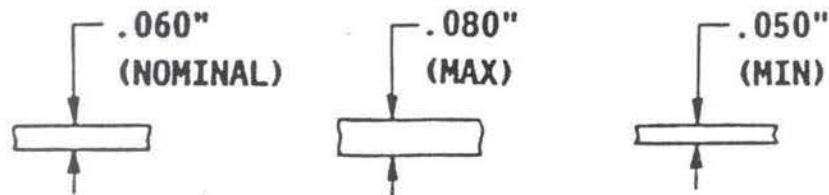

## CLAMPING OUT A GAP

- THUMB/FOREFINGER RULE (REF. PROCESS SPEC. 19000)

CAN A GAP (LOCALLY OR OVER 10" MAXIMUM) BE CLOSED USING ONLY THUMB AND FOREFINGER TIP PRESSURE?

IF YES - A SHIM IS PROBABLY NOT NECESSARY

IF NO - A SHIM OR REWORK IS REQUIRED

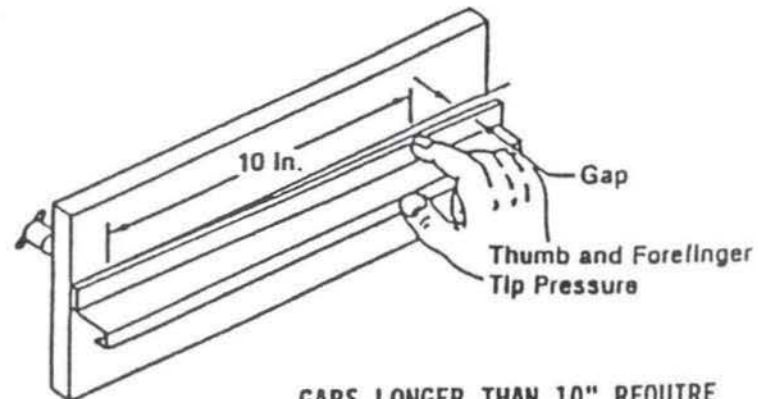
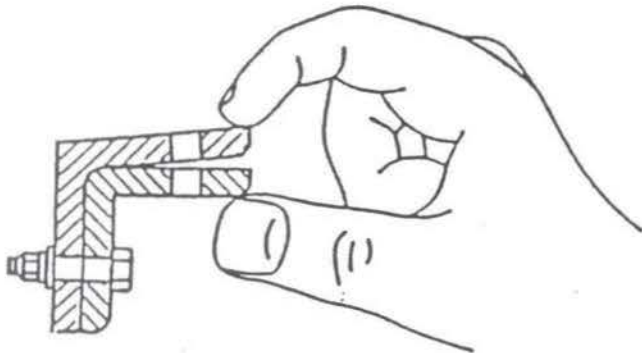

GAPS LONGER THAN 10" REQUIRE  
ENGINEERING CONSULTATION

AWARENESS BRIEFING

- FORCING PARTS INTO PLACE BY CLAMPING, HAMMERING, PRYING, ETC, IS UNDESIRABLE (CAUSES CRACKS).
- LOAD OR FORCE IS GREATLY INCREASED WHEN TOOLS ARE USED TO MAKE PARTS FIT.

RESULT: DAMAGED PARTS OR FUTURE CRACKS DEVELOP IN THE AREA.

HAND PRESSURE IS SMALL

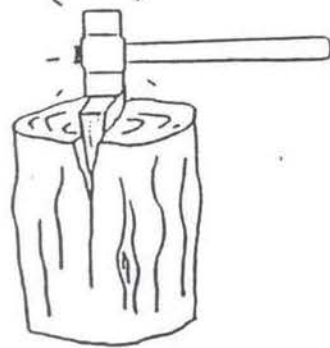

MUCH GREATER FORCE USING HAMMER

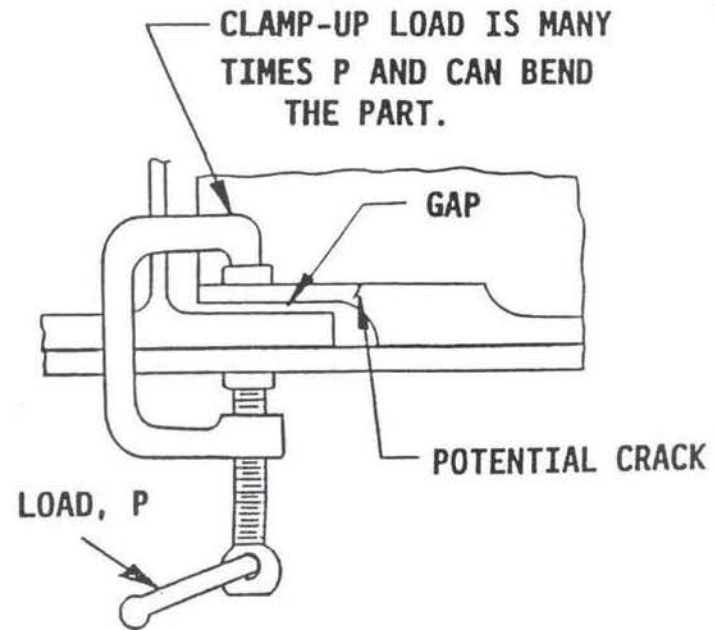

AWARENESS BRIEFING



IF IT DOESN'T FIT, DON'T FORCE IT

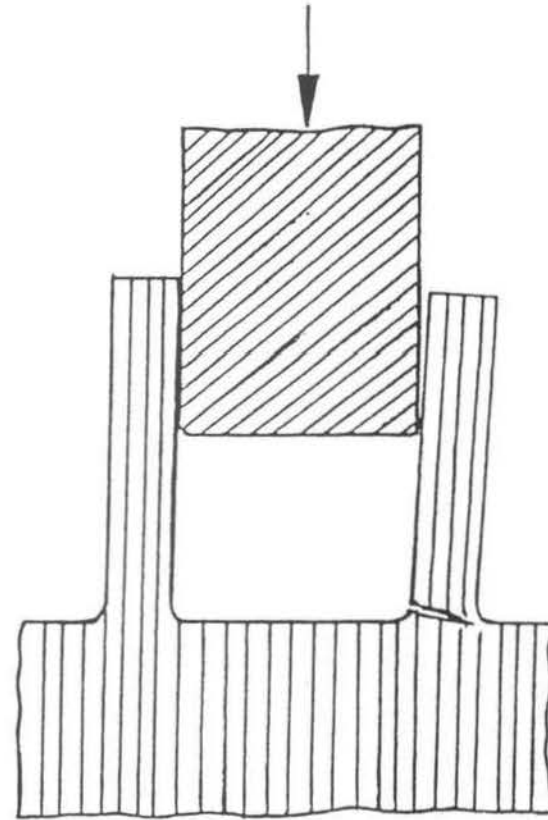
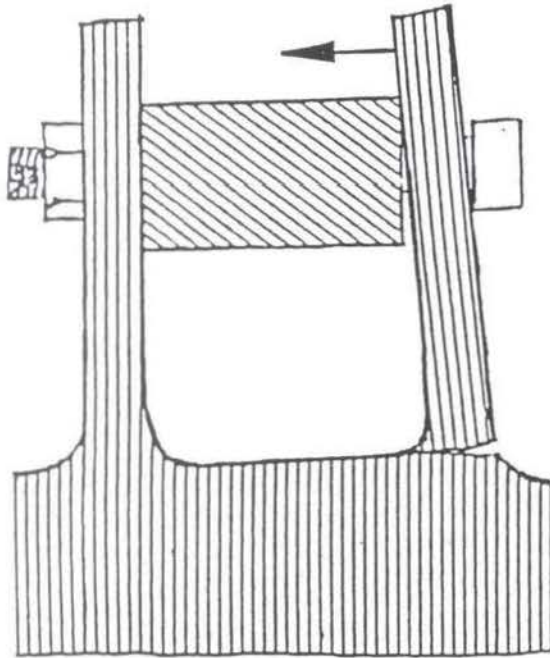

**AWARENESS BRIEFING**

PROPERLY DESIGNED SHIMS CAN MAKE ASSEMBLY OF PARTS EASIER.

- A. STRUCTURAL SHIM (ATTEMPTS TO RESTORE B/P STRENGTH CAPABILITY AND IMPROVES FASTENER BENDING)

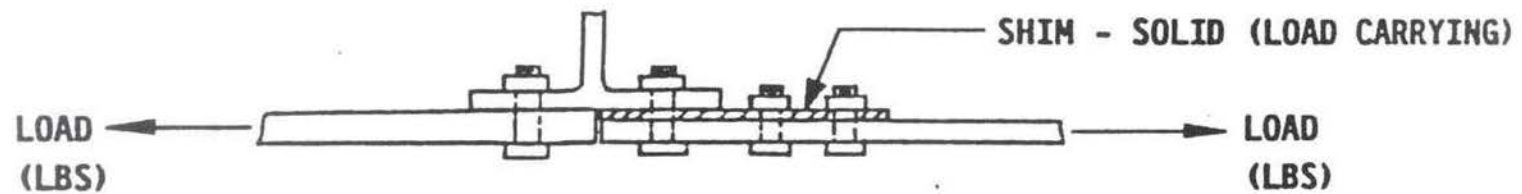

- B. NON-STRUCTURAL SHIM; GAP FILLERS ONLY (1 FASTENER)

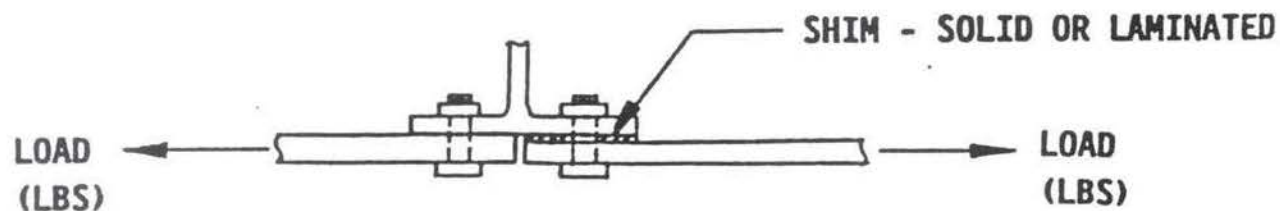

AWARENESS BRIEFING

- o HIGH LOADS/FORCES REMAIN IN A PART AFTER PULLING OUT A GAP
- o CRACKS MAY NOT OCCUR ON INSTALLATION, BUT CAN DEVELOP AND GROW OVER TIME.

### FLAP SCREW SUPPORT FITTING

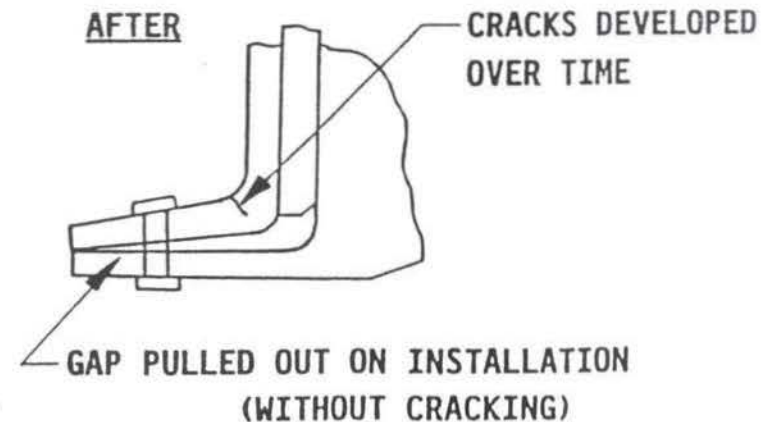
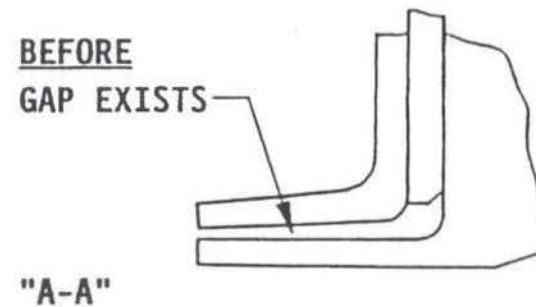
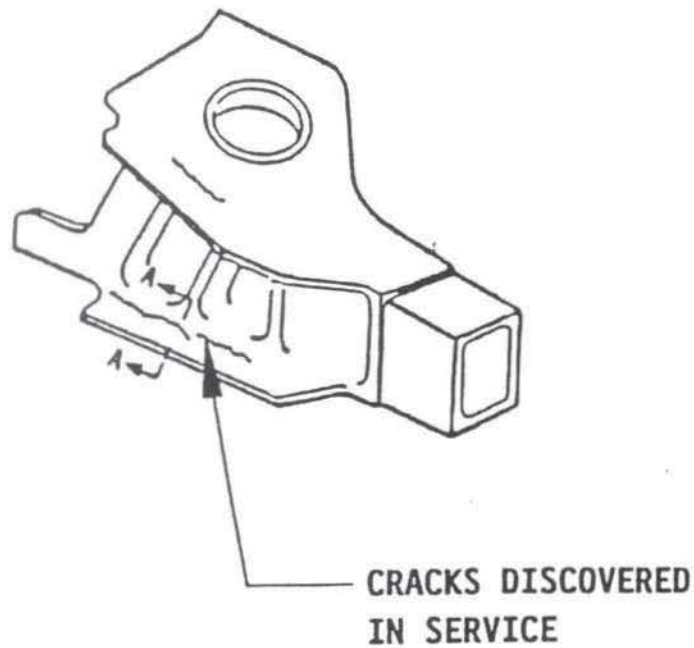

### AWARENESS BRIEFING

## DISADVANTAGES OF SHIMMED GAPS OR SPLICES

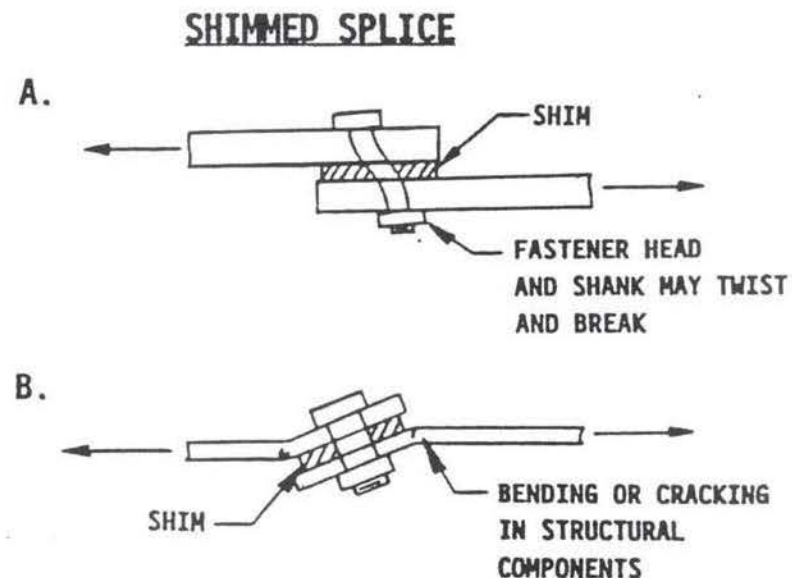
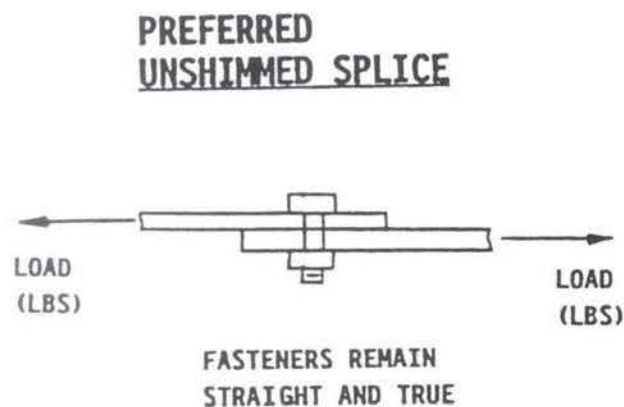

- THE GENERAL EFFECT OF A SHIM IS TO REDUCE THE STRENGTH OF A JOINT.
- THE CHANCE OF DEVELOPING PROBLEMS FROM SHIMS INCREASES AS SHIM THICKNESSES INCREASE.
- SHIM THICKNESSES GREATER THAN THOSE ALLOWED ON B/P'S MUST NOT BE INSTALLED WITHOUT LIAISON ENGINEERING DISPOSITION

**AWARENESS BRIEFING**

**SHIMMING GUIDELINES (FOR REFERENCE ONLY)**

- A. ALWAYS CONSULT LIAISON ENGINEERING WHEN SHIMS ARE NOT CALLED OUT ON THE BLUEPRINT.
- B. USE ONLY METAL SHIMS IN STRUCTURAL JOINTS.
- C. AVOID EXCESSIVE THICKNESS OF LAMINATED SHIMS. USE PART SOLID SHIMS WHEN THICKNESSES EXCEED .032".
- D. LIQUID SHIMS SHOULD ONLY BE USED IN LOW LOAD AREAS AND ARE ACCEPTABLE ONLY BY ENGINEERING DISPOSITION

**AWARENESS BRIEFING**

MOLDLINE BUTT GAPS: BLUEPRINT GAPS SHOULD BE MAINTAINED

- STRUCTURAL FLEXING DUE TO FLIGHT LOADS
- HIGH TEMPERATURE EXPANSION  
(HIGH SPEED FLIGHT CAUSES HIGH SURFACE TEMPERATURES)
- PARTS RUBBING TOGETHER REMOVES PROTECTIVE COATINGS

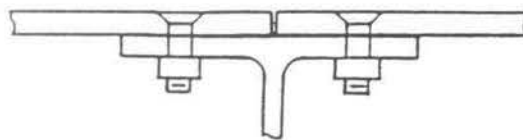
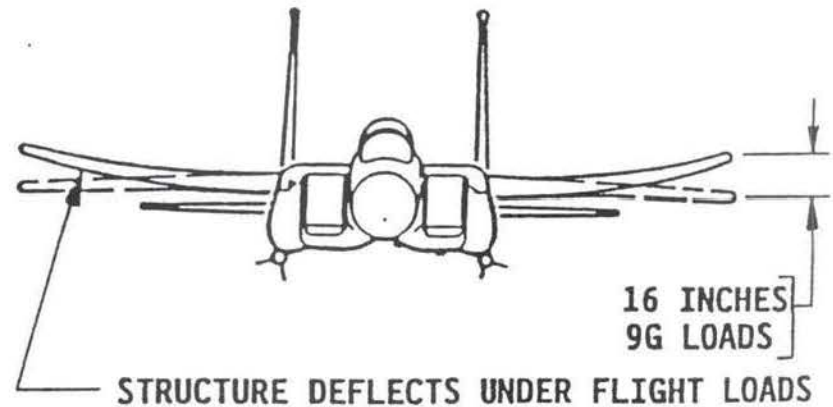
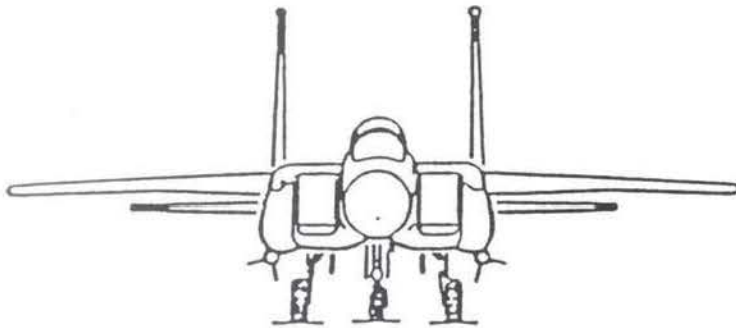

UNDEFLECTED CONDITION

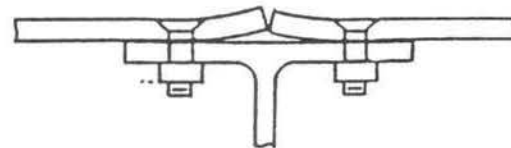

SKINS BUCKLE AND RUB TOGETHER IF MOLDLINE GAPS ARE NOT MAINTAINED

AWARENESS BRIEFING

## MOLDLINE BUTT GAPS

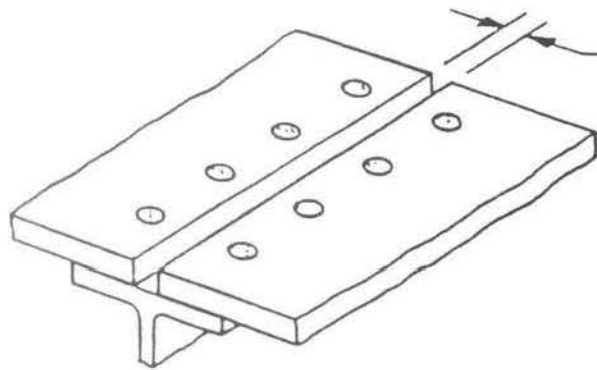

MINIMUM .010" (UNLESS SPECIFIED OTHERWISE)  
MAXIMUM .020" TO .120" DEPENDING ON TYPE OF  
STRUCTURE

REF. DWG 68A900001 FOR ALLOWABLE GAPS  
(68A327000 FOR THE INLET AIR DUCT)

AWARENESS BRIEFING



TRIMMING

AWARENESS BRIEFING



## REASONS FOR TRIMMING

- \* POOR FIT WITH MATING PARTS
- \* NICKS, GOUGES, CRACKS, DRILL MARKS
- \* HOLES FALLING IN OR NEAR STEPS, FLANGES OR ADJACENT PARTS

AWARENESS BRIEFING

## PRECAUTIONS WHEN TRIMMING

- \* REMOVING TOO MUCH THICKNESS
- \* REDUCTION OF FLANGE WIDTH - ESPECIALLY AREADY SHORT STIFFENING ("RETURN") FLANGES
- \* MACHINED STEPS (TRANSITIONS) TOO SHORT
- \* TRIM TOO CLOSE TO HOLES
- \* TOO SMALL CORNER/FILLET RADII
- \* POOR SURFACE FINISH
- \* MAKING SHARP EDGES
- \* TRIM PROFILE TOO SHARP - NOT GRADUAL

AWARENESS BRIEFING

BLENDING MAY REMOVE .000 MUCH THICKNESS

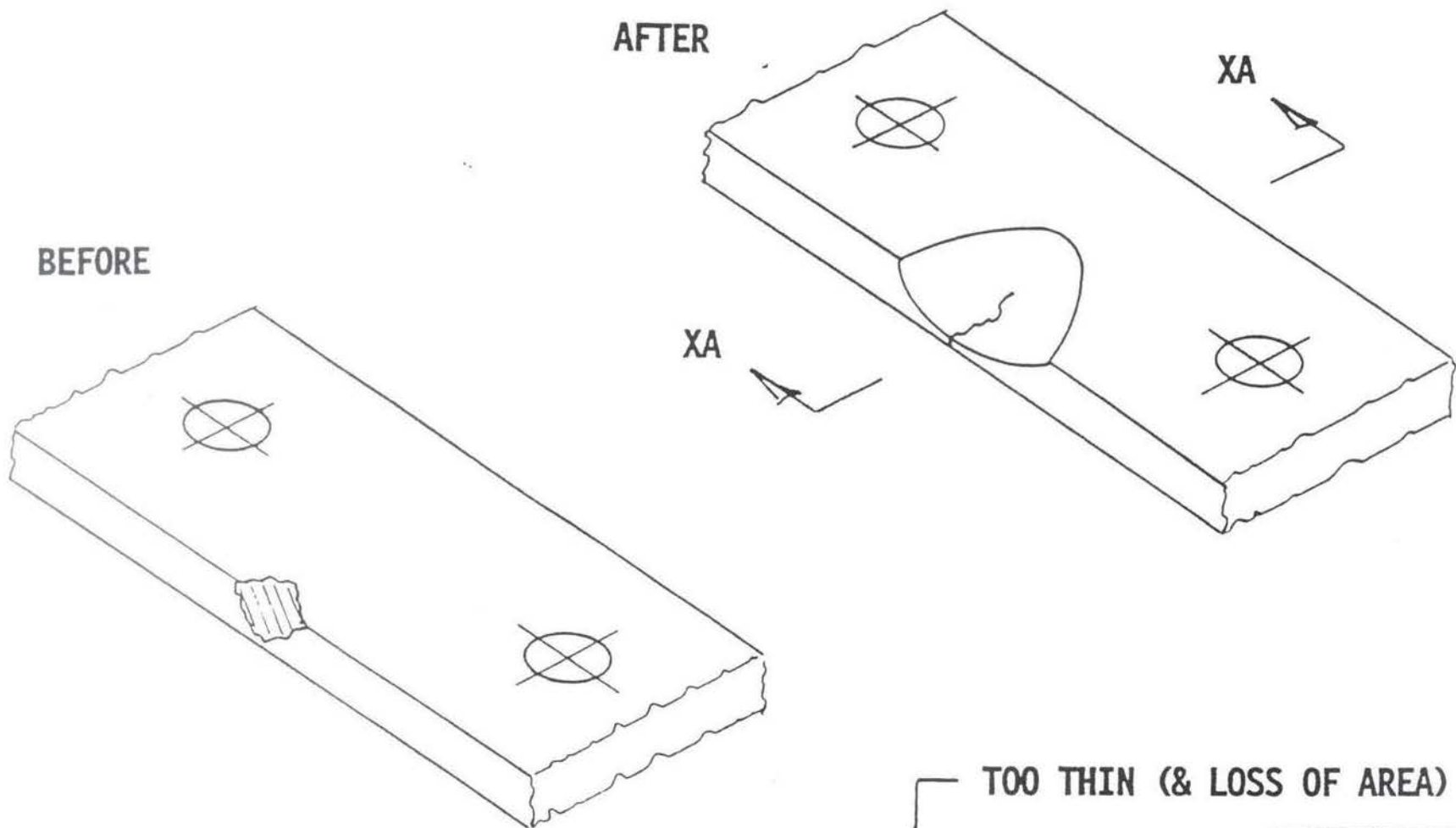

AWARENESS BRIEFING

SECT XA - XA

# TRIMMED RETURN FLANGES CAN HURT

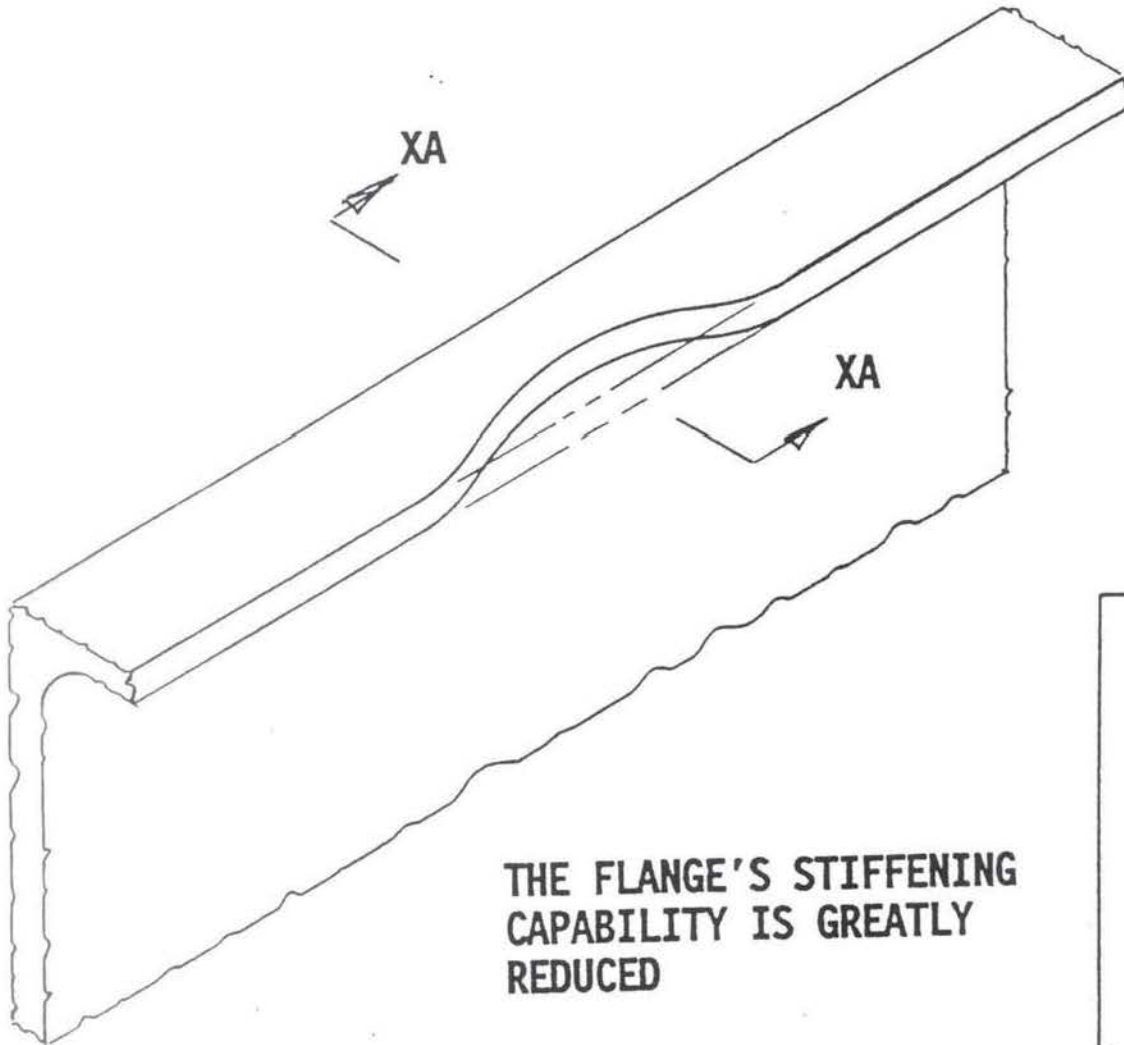

THE FLANGE'S STIFFENING  
CAPABILITY IS GREATLY  
REDUCED

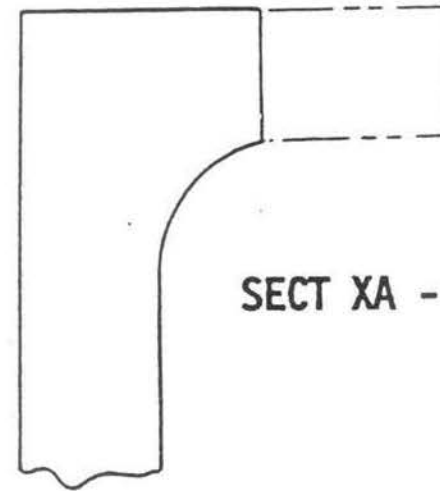

SECT XA - XA

# REWORKING A FLANGE STEP TOO SHORT

BEFORE

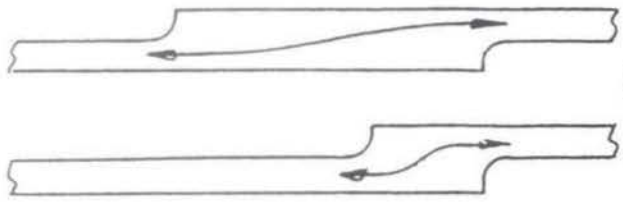

SECT XA - XA

AFTER

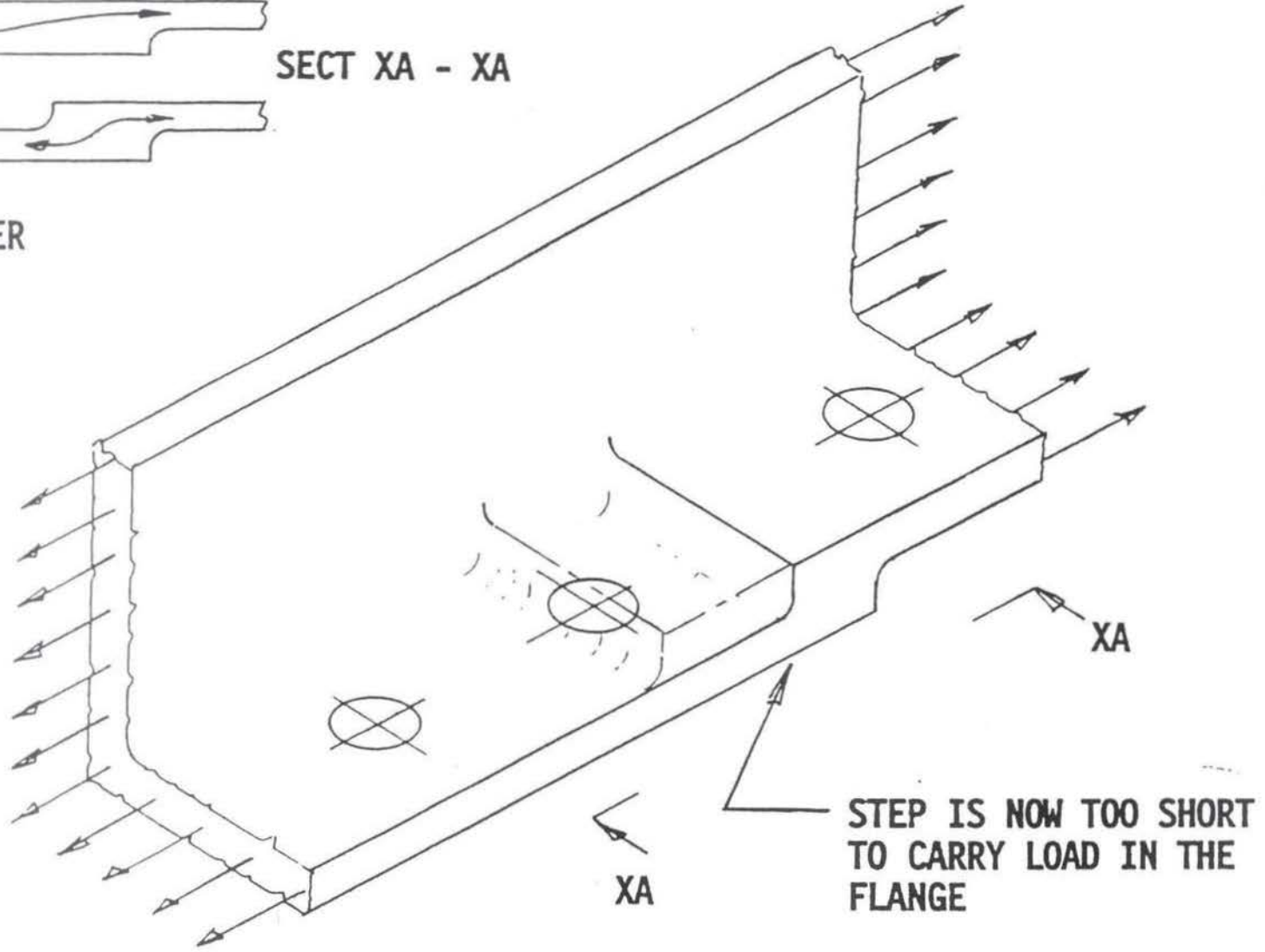

STEP IS NOW TOO SHORT TO CARRY LOAD IN THE FLANGE

TRIMMING TOOL USE TO HOLES

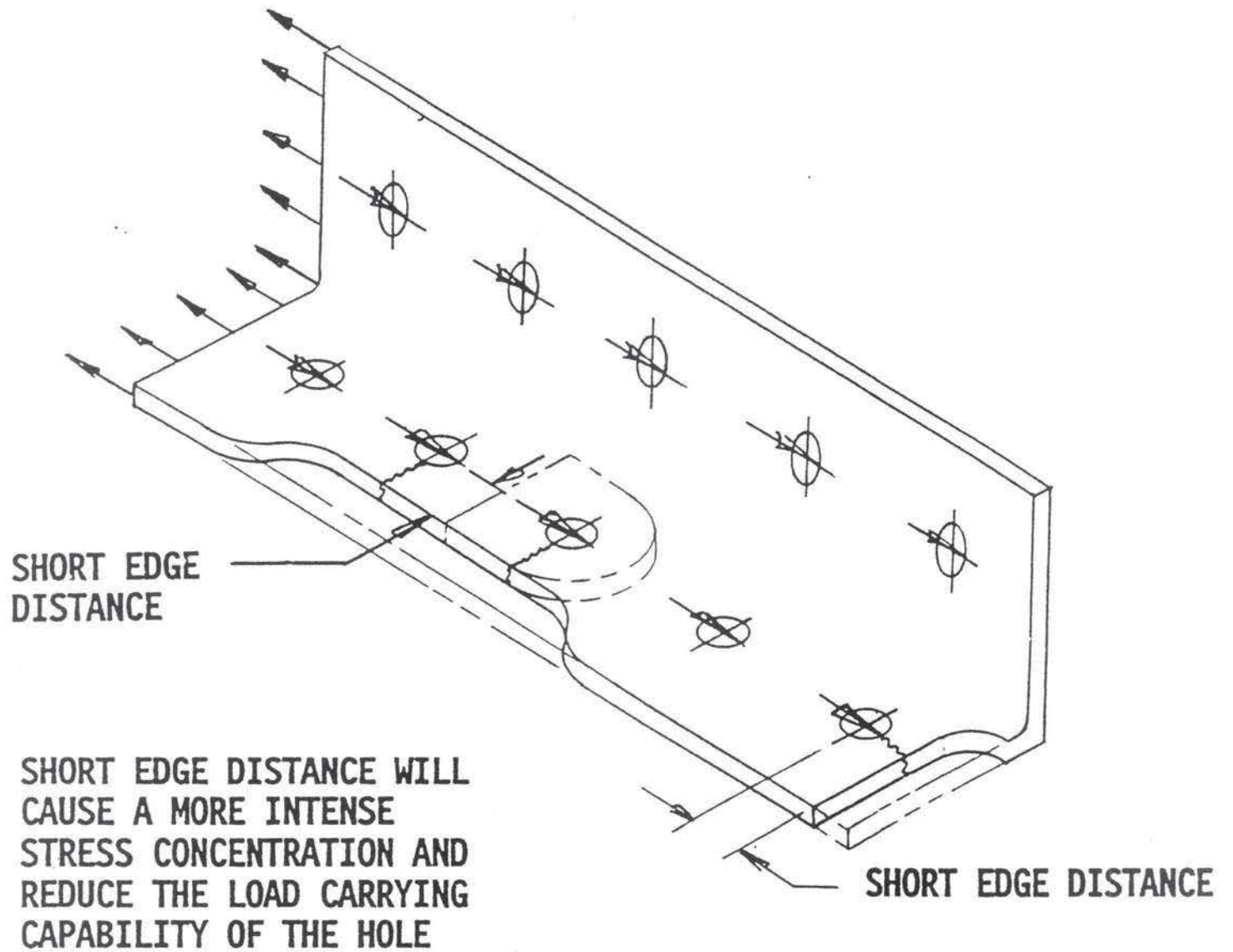
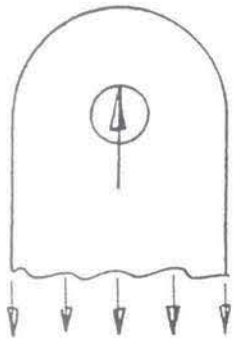

SHORT EDGE DISTANCE

SHORT EDGE DISTANCE WILL CAUSE A MORE INTENSE STRESS CONCENTRATION AND REDUCE THE LOAD CARRYING CAPABILITY OF THE HOLE

SHORT EDGE DISTANCE



CRACKS STARTING @ S .RP CORNER RADIUS

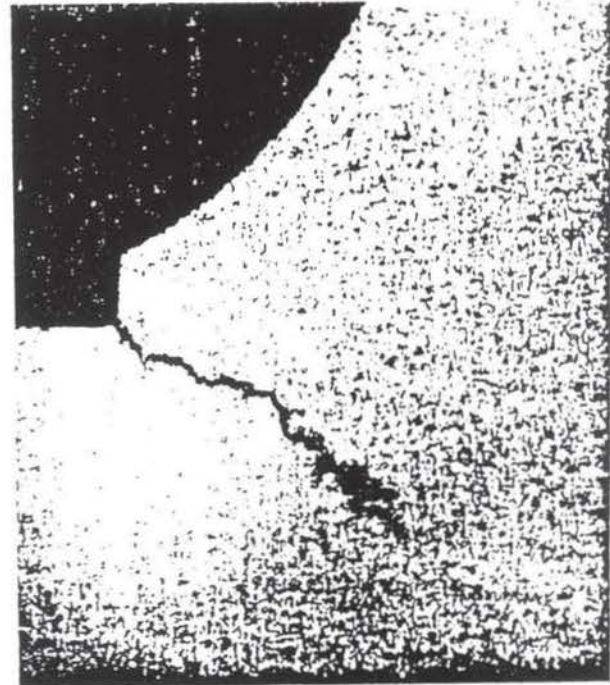
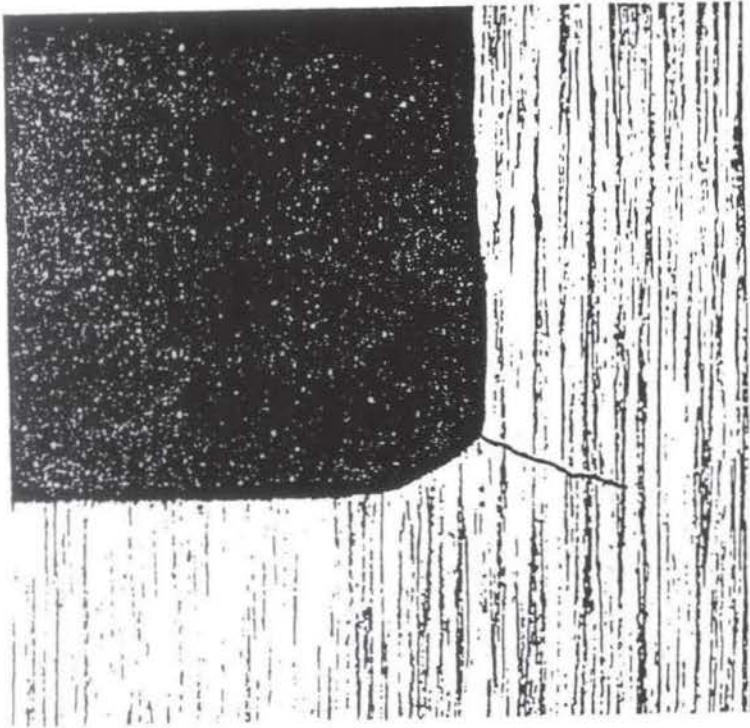

# FILLET RADIUS REWORK

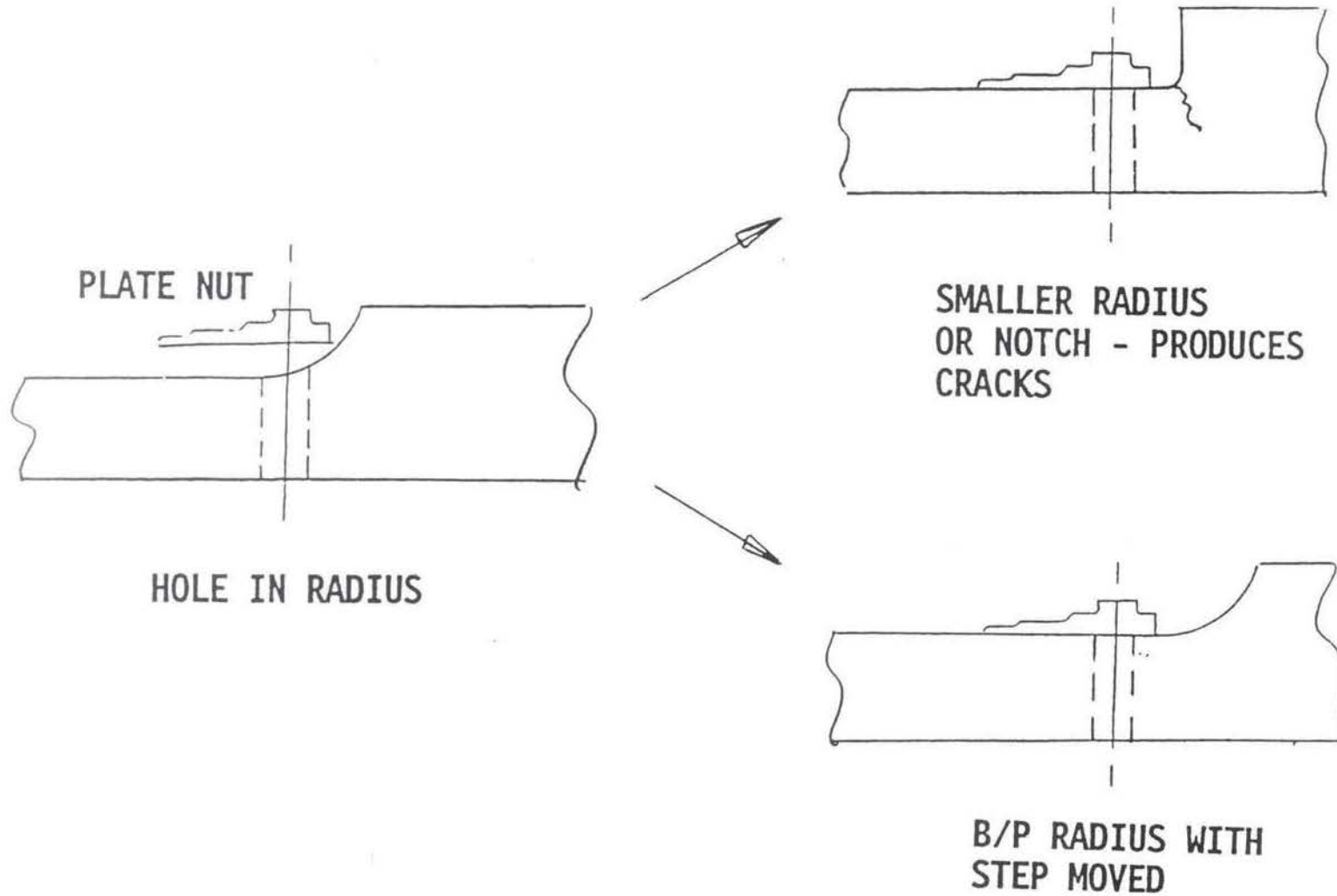



# ROUGH SURFACE FINISH

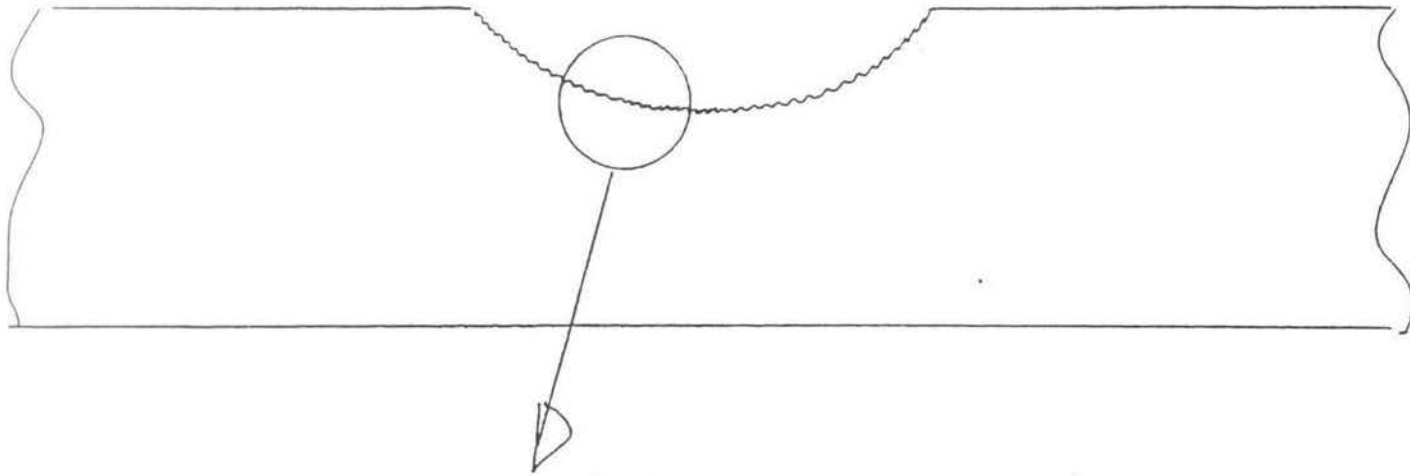

MAGNIFIED  
100 TIMES

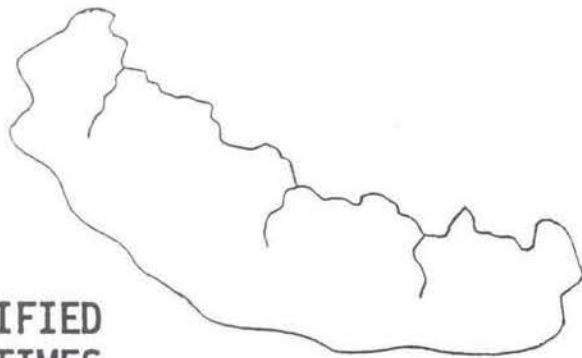

ROUGH SURFACE - A  
GOOD START FOR CRACKS

# MAKING SHARP EDGES

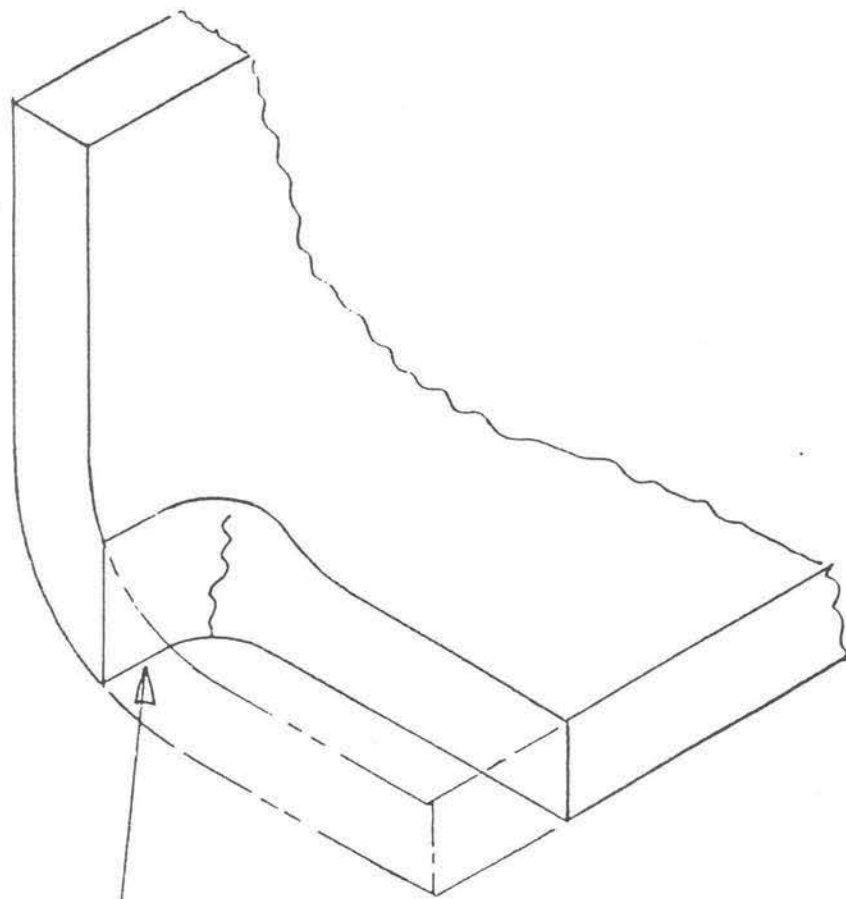

SHARP EDGE PRODUCED BY  
AN ANGLE CUT THRU A  
BEND RADIUS

# CRACK EXTENDING FROM FEATHERED EDGE

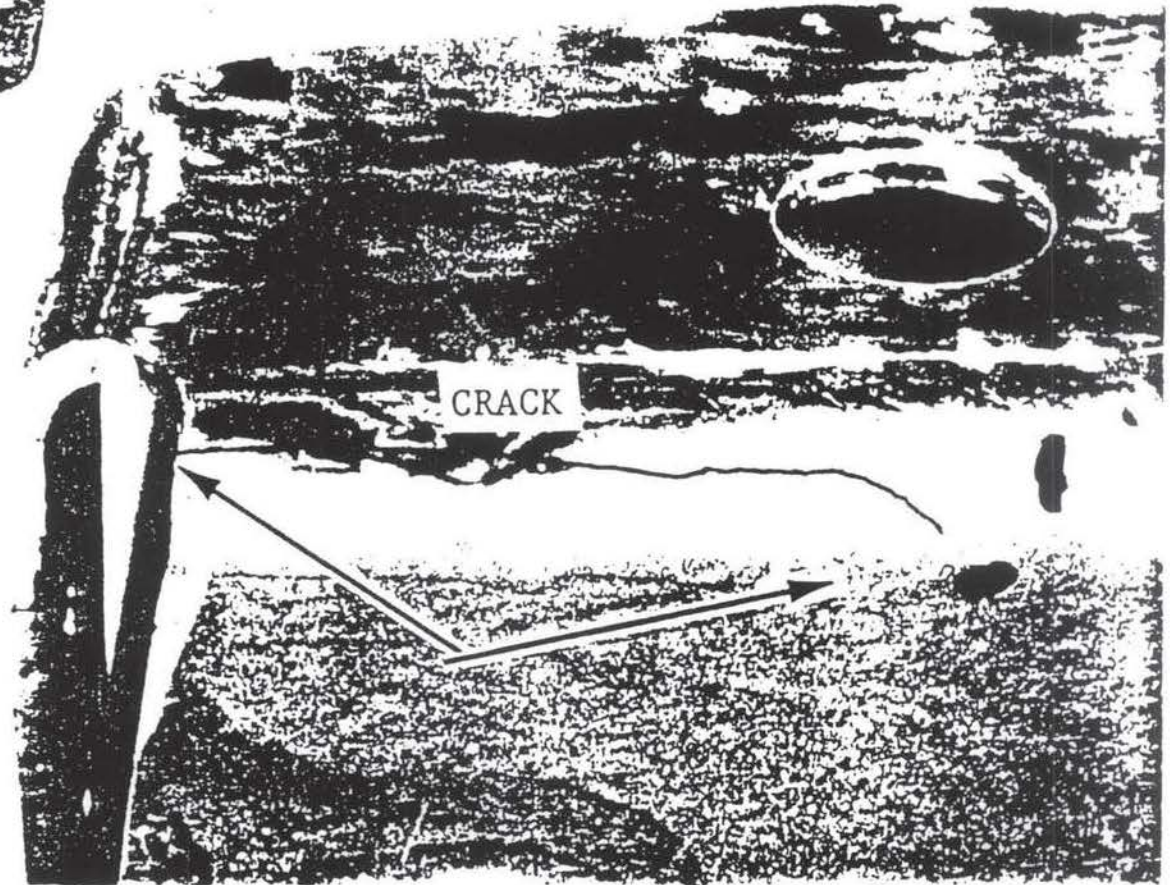
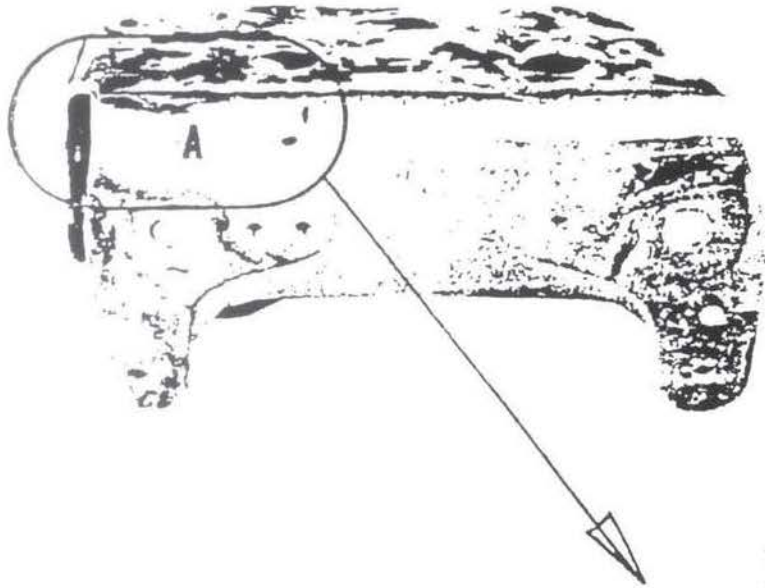

AWARENESS BRIEFING

Location A

## GRADUAL VS SHARP BLENDING

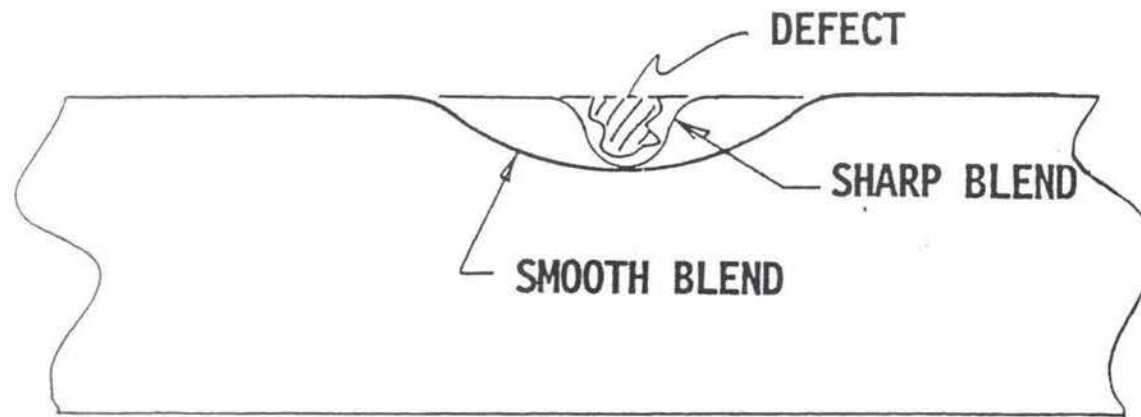

BOTH BLENDS REMOVE DEFECT  
BUT SHARP BLEND MAY STILL BE  
AN UNACCEPTABLE STRESS RISER -  
THE STRESS INTENSITY MAY BE  
TWICE AS GREAT FOR THE SHARP  
BLEND AS OPPOSED TO A  
SMOOTH, GRADUAL BLEND.



# LUG ON F4 WII. FOLD RIB

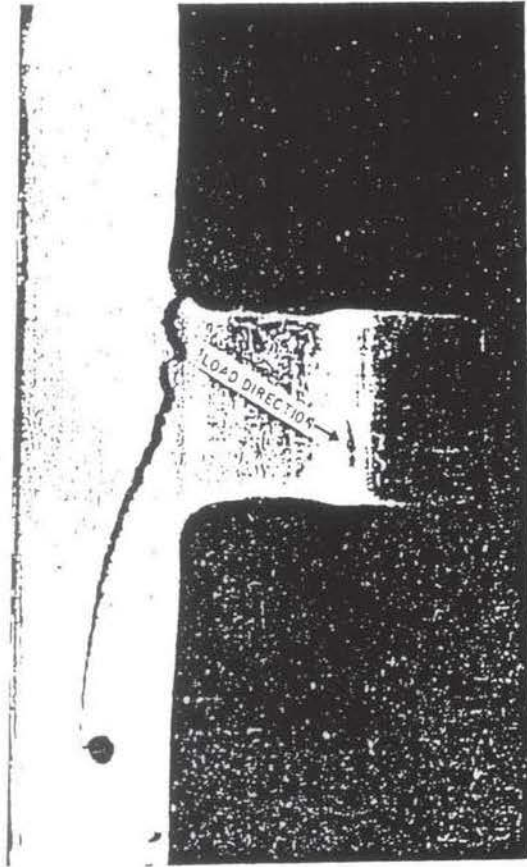

ORIGINAL LIFE = X CYCLES

LARGER  
RADIUS

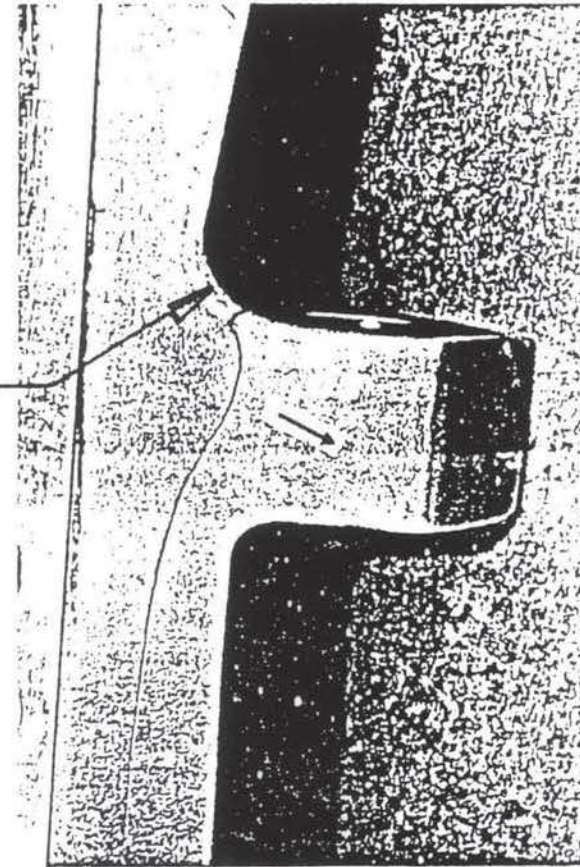

REDESIGNED LIFE = 8X CYCLES

## SMOOTH, GRADUAL TRANSITIONS

- \* LOAD FLOWS EASIER
- \* AVOIDS THE STRESS RISERS THAT CAUSE CRACKS

AWARENESS BRIEFING

REMEMBER THE ROCK IN THE STREAM

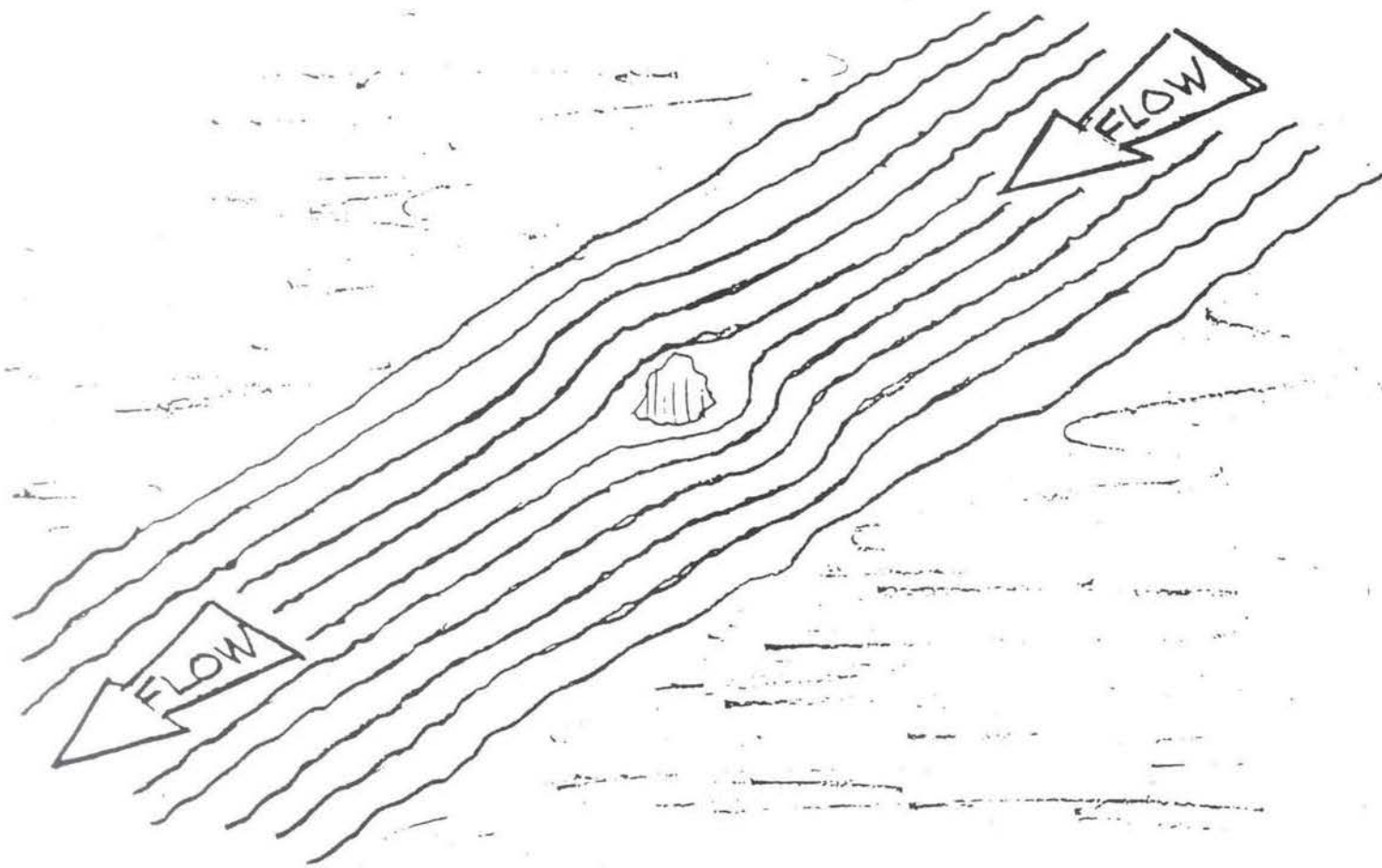

LOAD MUST FLOW AROUND  
OBSTACLES

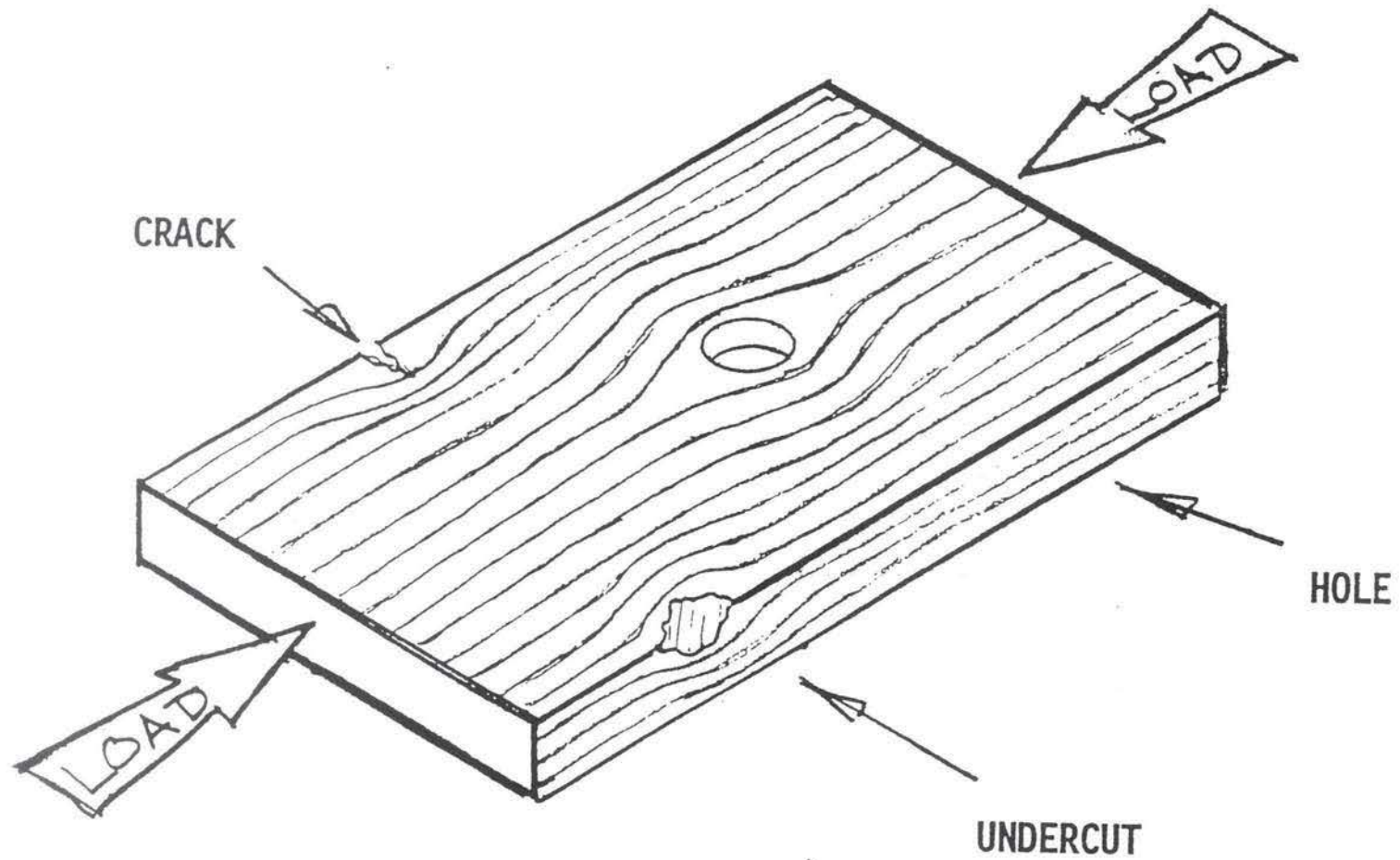



# TYPICAL TRIM OF SHEET METAL OR EXTRUDED FLANGES TO PERMIT FIT UP OF PARTS

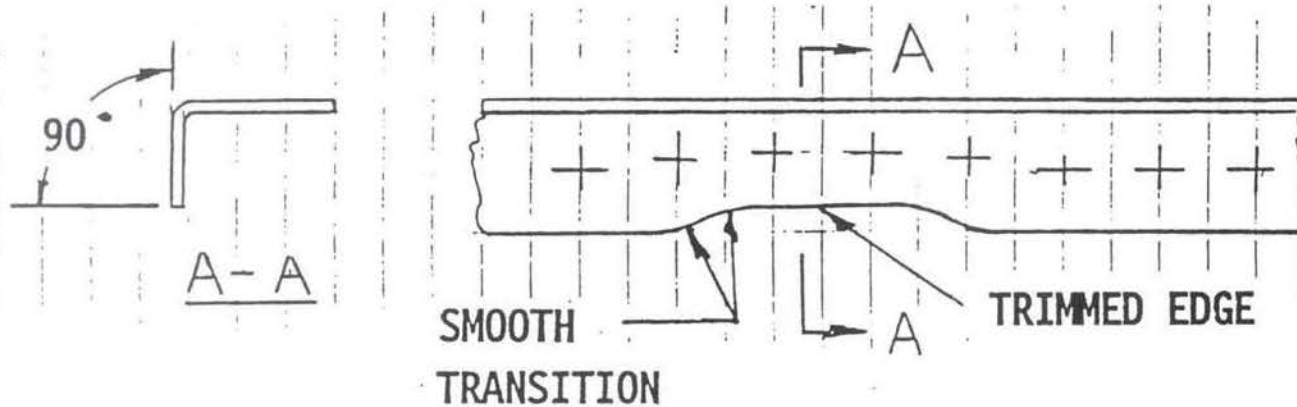

- o TRIMMED EDGE TO BE SMOOTH
- o NO NICKS OR NOTCHES
- o NO CUT MARKS
- o MAINTAIN B/P EDGE DISTANCE

# TYPICAL TRIM OF EXTRUDED ANGLE TO PERMIT FIT UP OF PARTS

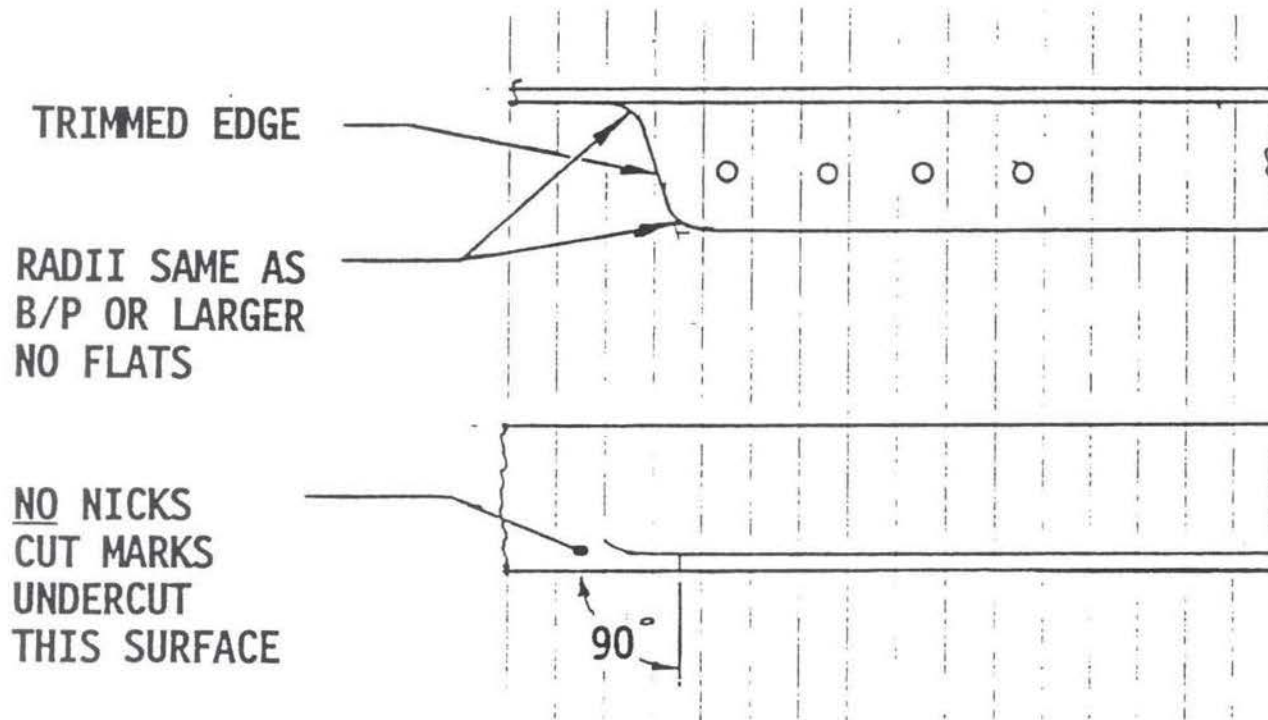

- o ALL SURFACES TO BE SMOOTH
- o NO NICKS OR NOTCHES
- o NO CUT MARKS
- o MAINTAIN B/P EDGE DISTANCE

# TRIMMING OF BEND RELIEF TO CLEAR ADJACENT PARTS

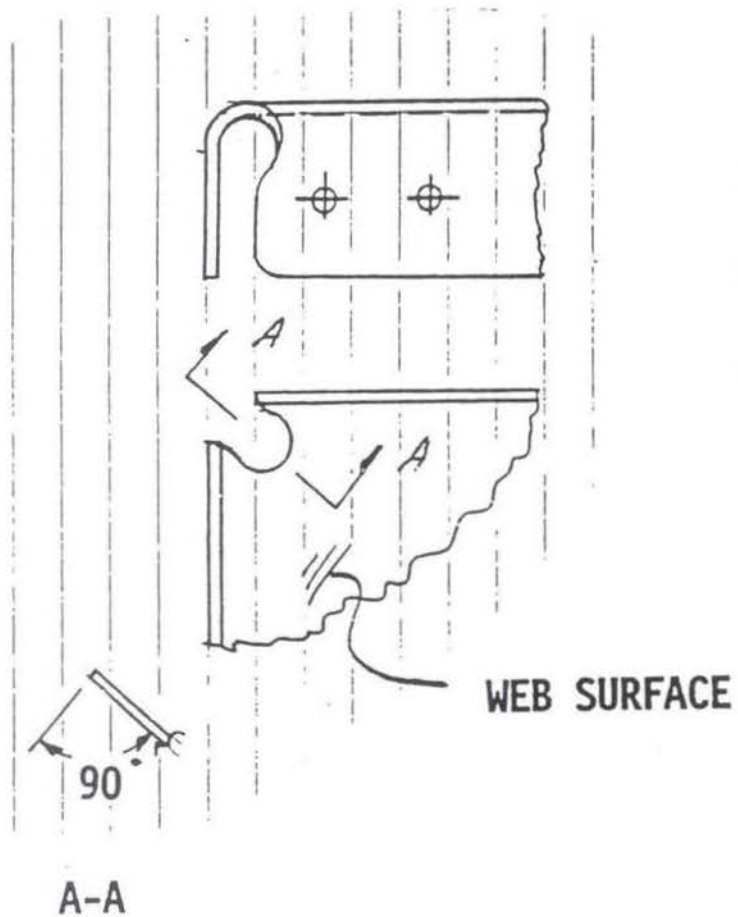

- o NO NICKS OR NOTCHES
- o CONSTANT RADIUS TRIM
- o TRIM 90° TO WEB SECT A-A
- o MAINTAIN B/P EDGE DISTANCE

# GUIDE LINES FOR CHAMFERS

WHEN ADDING CHAMFER TO A PART, THE THICKNESS REMAINING MUST BE .020 OR GREATER OR CRACKING WILL DEVELOP AND CAUSE PARTS TO FAIL.

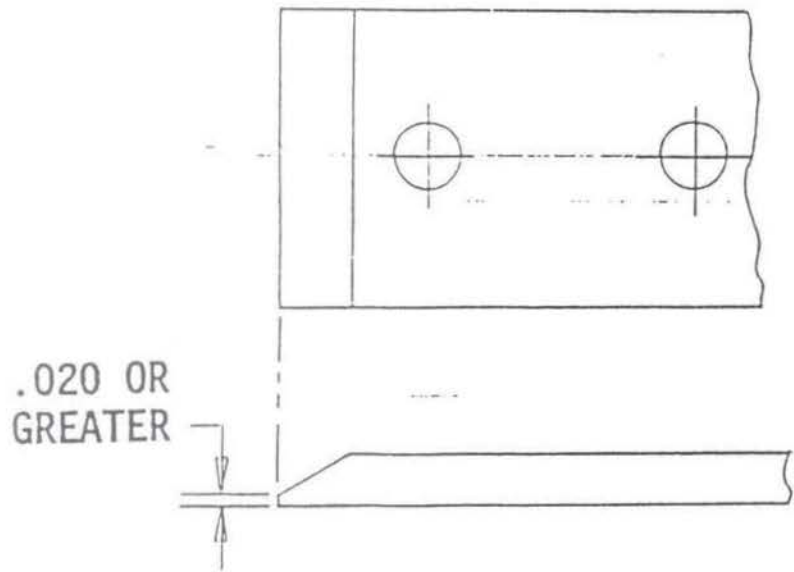

(RECOMMENDED)

CRACKS WILL DEVELOP AS RESULT OF KNIFE EDGE CONDITION

LESS THAN .020, CONSIDER AS KNIFE EDGE

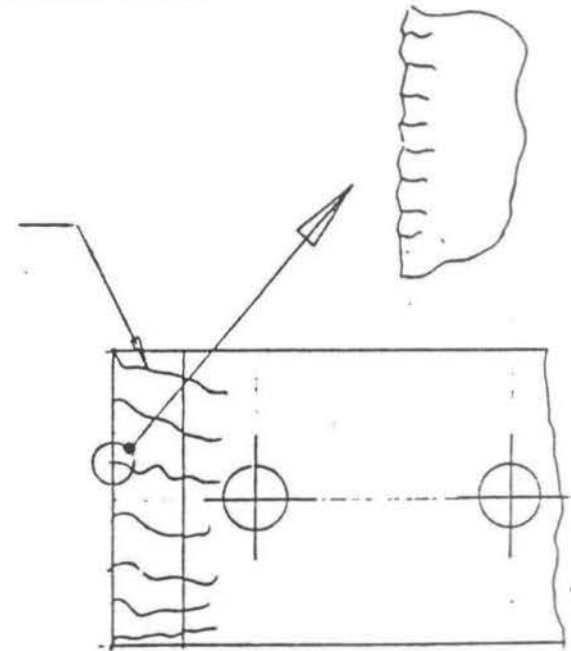

(NOT RECOMMENDED)

(GUIDE LINES ON CHAMFERS)  
CHAMFERING OF INTERSECTION OF FLANGES

CRACK LIKELY TO DEVELOP HERE AND CAUSE PART FAILURE

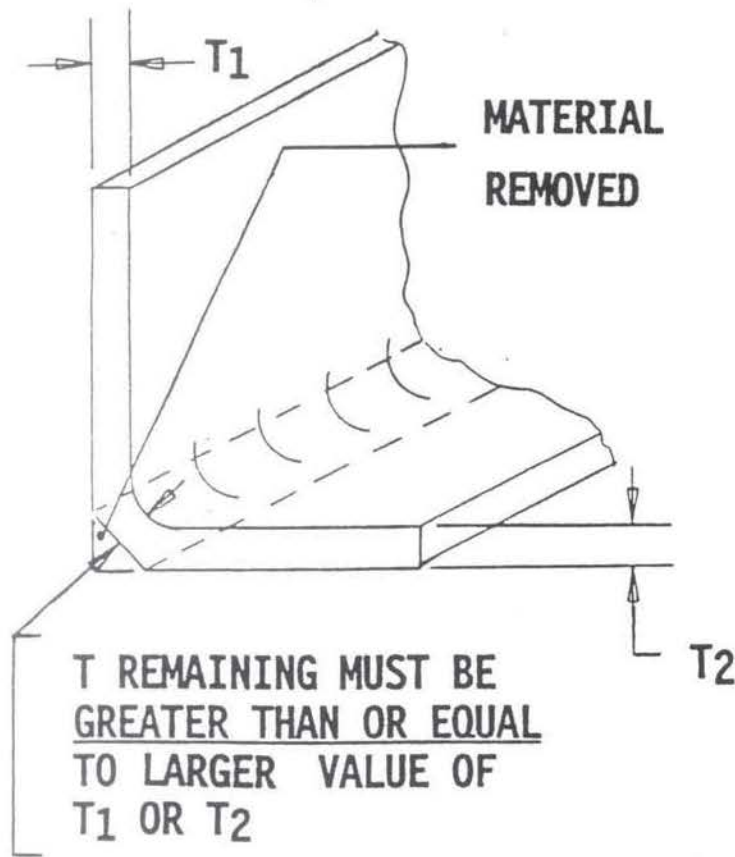

(RECOMMENDED)

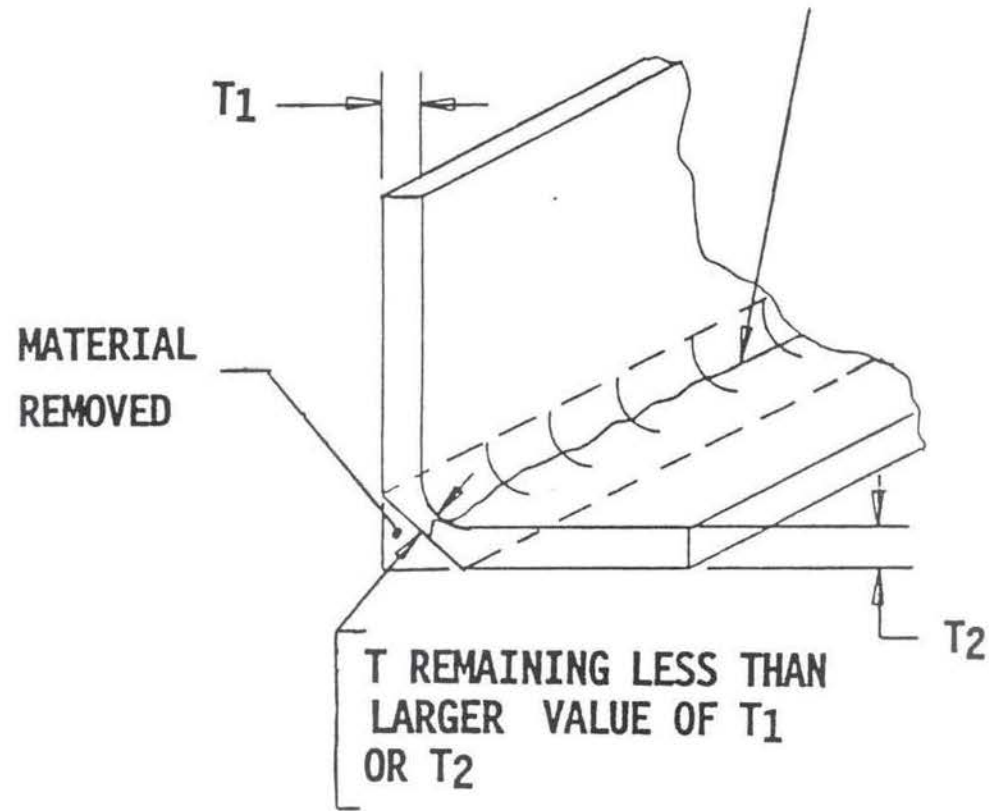

(NOT RECOMMENDED)

SMOOTHER IS BETTER

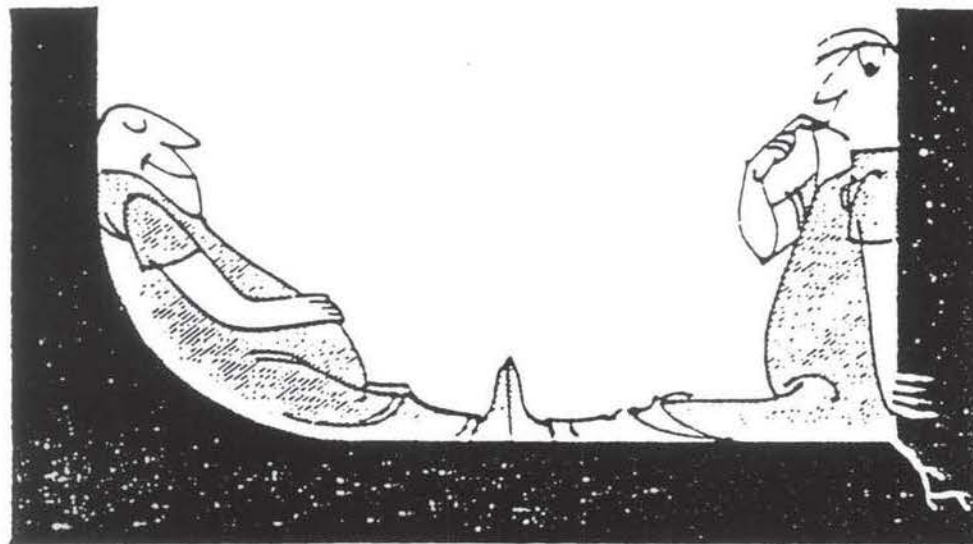

AWARENESS BRIEFING

# FASTENERS

AWARENESS BRIEFING

# FASTENERS WORK IN 2 WAYS

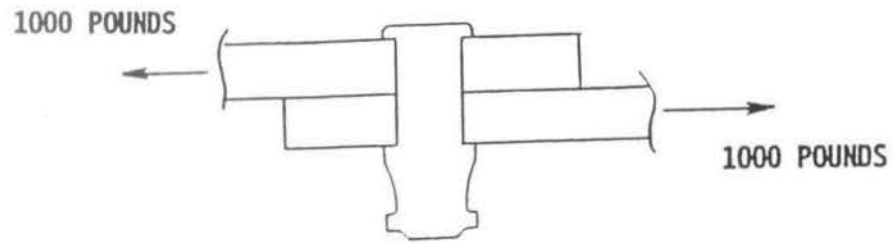

**SHEAR**  
**(MOST COMMON)**

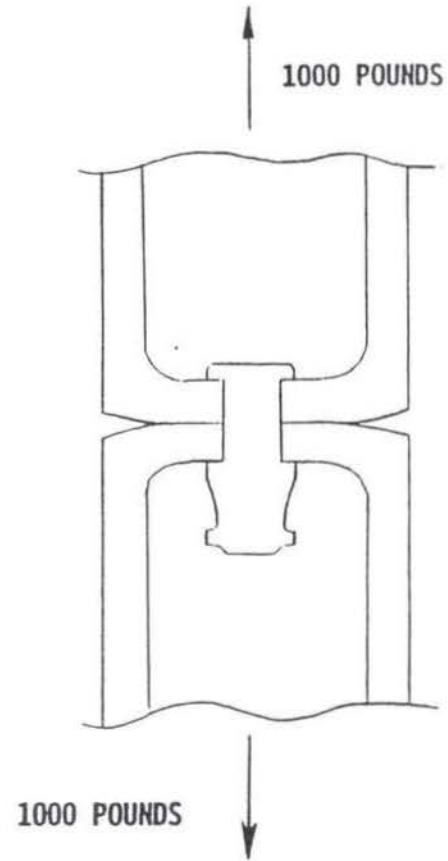

**TENSION**

**AWARENESS BRIEFING**



## FASTENER MATERIAL IS IMPORTANT

- A STEEL FASTENER IS OVER 3 TIMES STRONGER THAN THE SAME FASTENER MADE FROM ALUMINUM
- A TITANIUM FASTENER IS OVER 2 TIMES STRONGER THAN THE SAME FASTENER MADE FROM ALUMINUM
- ALL TYPES OF STEEL ARE NOT THE SAME
- ALL TYPES OF ALUMINUM ARE NOT THE SAME

AWARENESS BRIEFING

## FASTENER COATINGS

WHEN CERTAIN METALS COME INTO CONTACT, CORROSION OCCURS

- SIMILAR TO THE WAY IRON RUSTS
- EXAMPLES: ALUMINUM VS STEEL; ALUMINUM VS TITANIUM

FASTENER COATINGS PREVENT THIS FROM HAPPENING

- EXAMPLES: IVD COAT, CAD PLATE, INSTALLING "WET"
- IF THE WRONG COATING IS USED, IT CAN ALSO CAUSE PROBLEMS
- EXAMPLE: CAD PLATED FASTENER IN TITANIUM IS NOT ACCEPTABLE

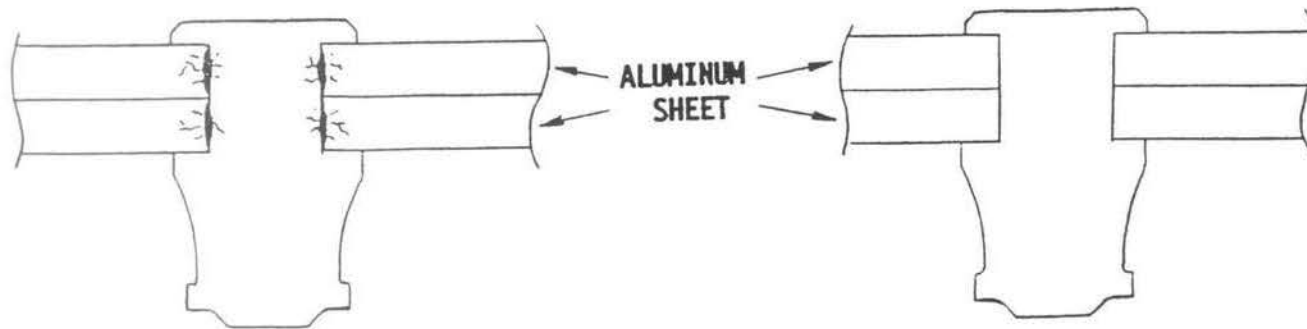

STEEL FASTENER  
WITHOUT ANY COAT

STEEL FASTENER  
WITH IVD COAT

AWARENESS BRIEFING

## SHORT EDGE DISTANCE CAUSES CRACKS

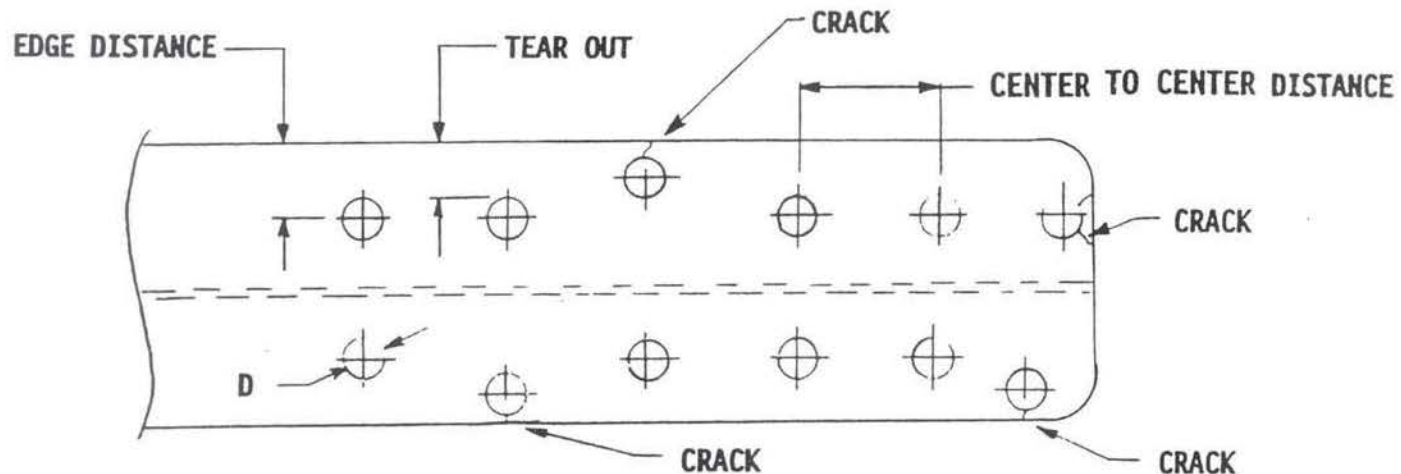

- THE SHORTER THE EDGE DISTANCE, THE HIGHER THE STRESS RISER
- THE CONSEQUENCE OF SHORT EDGE DISTANCE VARIES FROM PART TO PART  
1) IN HIGHLY LOADED PARTS, SHORT E.D. IS MUCH MORE CRITICAL
- ALL OF THIS WAS CAREFULLY CONSIDERED TO DEVELOP THE REQUIREMENT FOR 2D PLUS .03 EDGE DISTANCE
- SHORT EDGE DISTANCE IS ACCEPTABLE ONLY BY ENGINEERING DISPOSITION

AWARENESS BRIEFING

**THE LOCATION OF PLATENUT/MILSON RIVETS IS IMPORTANT**

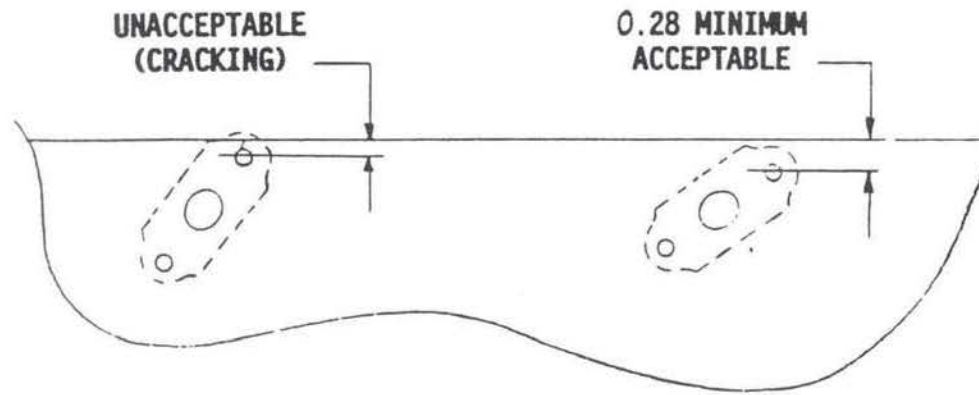

**PLATENUT RIVETS ARE IMPORTANT TOO**

CRACK INITIATES WHEN RIVET HAS SHORT EDGE DISTANCE

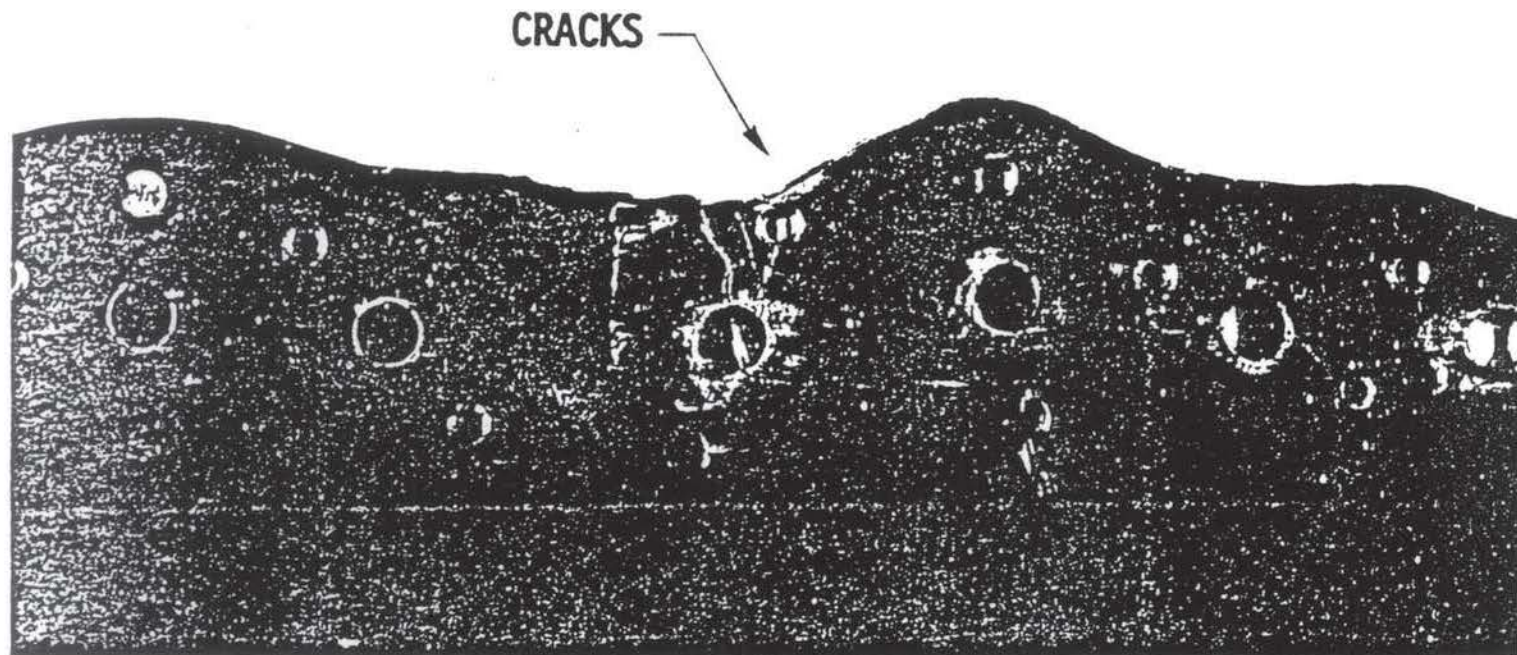

AWARENESS BRIEFING



# DOUBLE DRILLED, OBLONG, AND OVERSIZED HOLES MUST BE AVOIDED

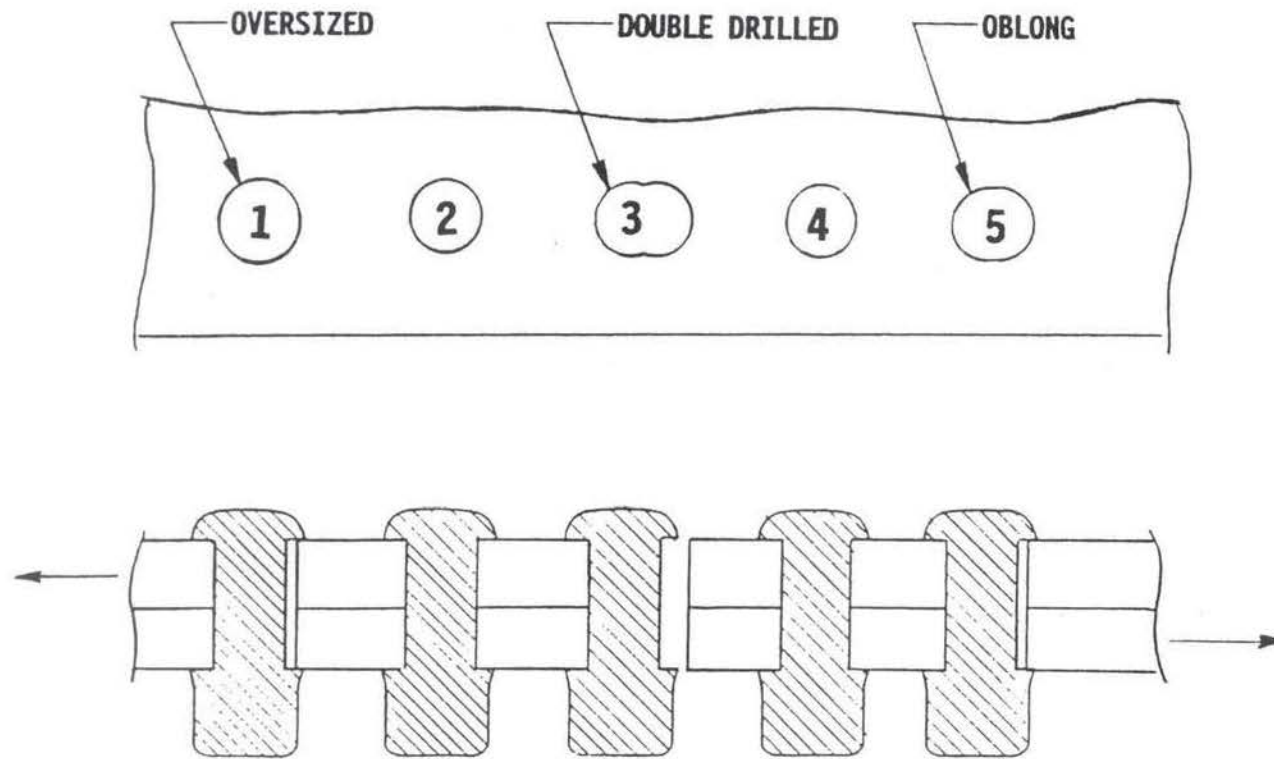

- INSTEAD OF FIVE FASTENERS HOLDING THE PARTS TOGETHER, TWO MUST DO THE JOB (#2, #4)
- THREE FASTENERS DON'T WORK (#1, #3, #5)

AWARENESS BRIEFING

## COUNTERSINK DEPTH IS IMPORTANT

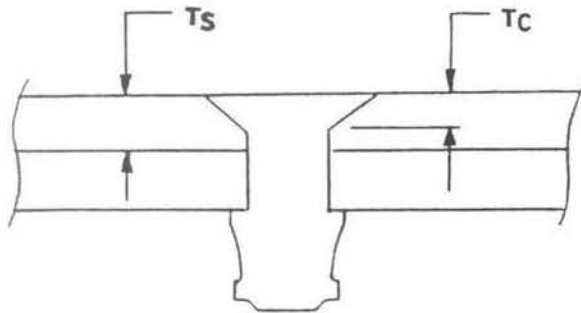

IF THE COUNTERSINK ( $T_c$ )  
IS LESS THAN 70% THE  
SHEET THICKNESS ( $T_s$ ) -  
NO PROBLEM

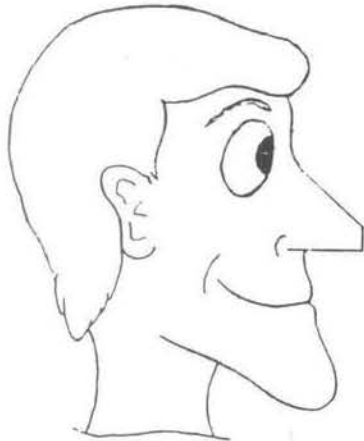

AWARENESS BRIEFING

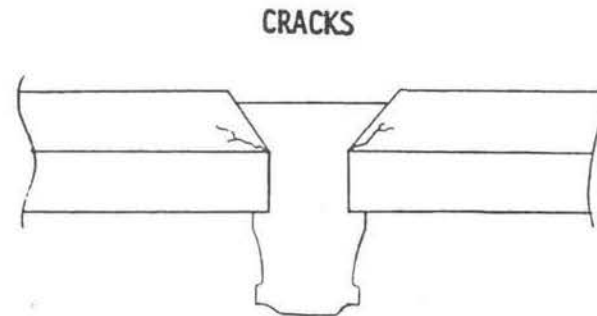

KNIFE EDGES CAUSE CRACKS  
- SIMILAR TO FEATHER EDGE

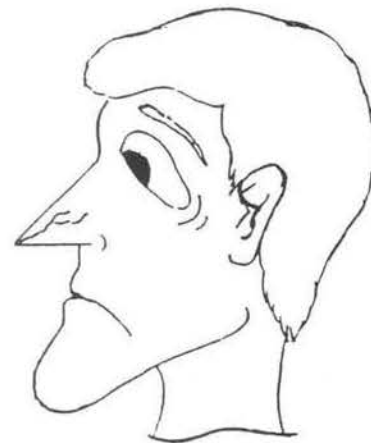

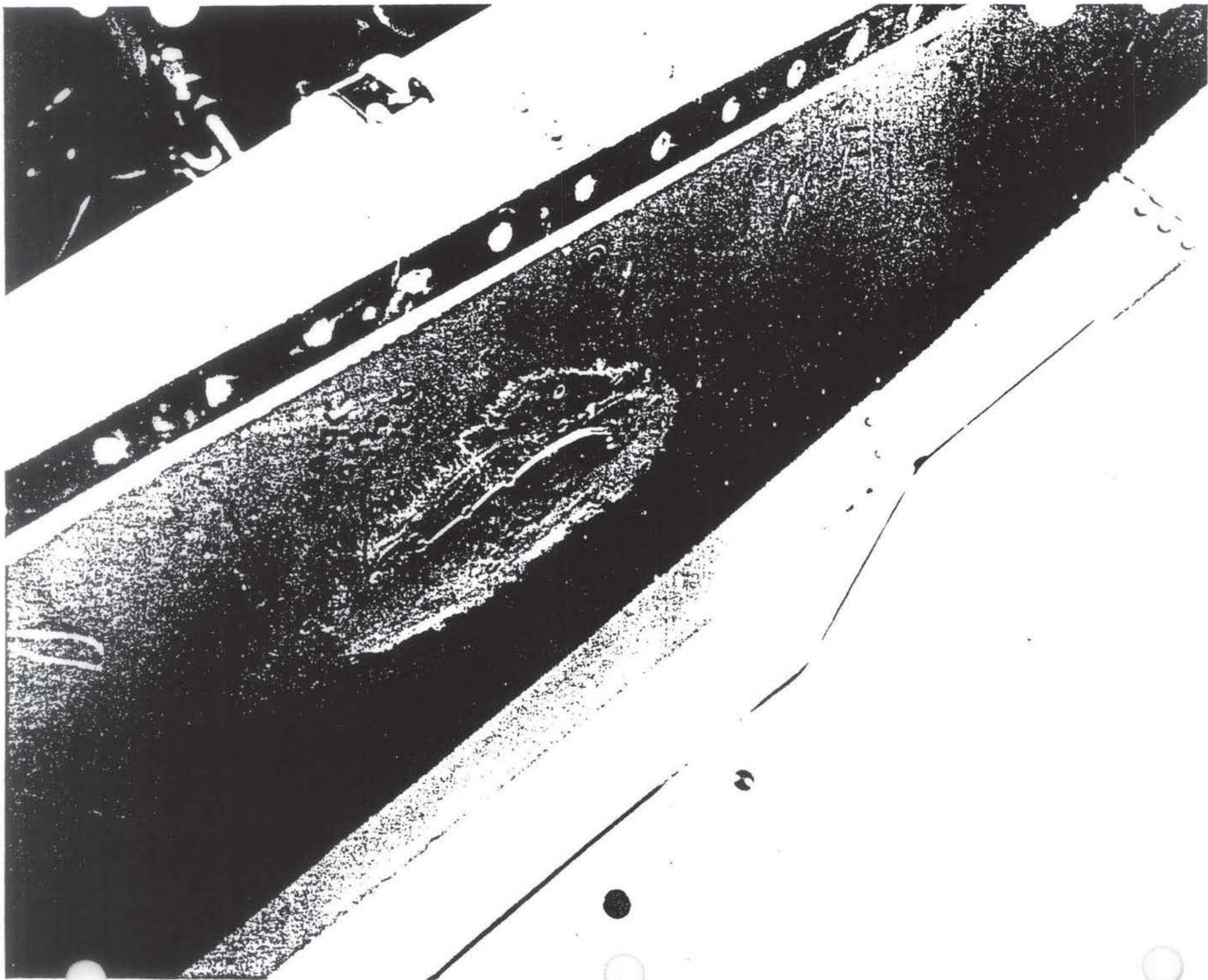



## DEBURRING FASTENER HOLES

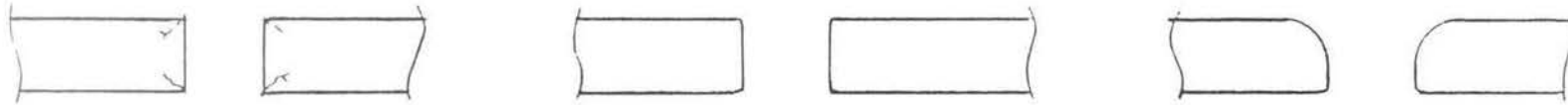

**BURRS AND SHARP  
EDGES ARE GREAT  
PLACES FOR CRACKS  
TO START**

- **ROUGH, JAGGED EDGE**
- **ONCE A CRACK STARTS  
IT SPREADS INTO THE  
PART ITSELF.**

**A GOOD DEBURRING  
SOLVES THE  
PROBLEM**

**TOO MUCH ISN'T  
NECESSARILY A GOOD  
THING. OVER-DEBURRING  
REDUCES PART AND  
FASTENER STRENGTH  
BY REDUCING BEARING  
SURFACE AND ALLOWABLE  
FASTENER BENDING.**

**AWARENESS BRIEFING**

**FASTENERS SHOULDN'T BE TOO CLOSE TO CHEM MIL/MACHINE STEPS**

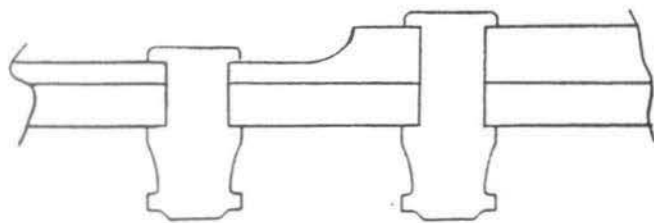

**GOOD**

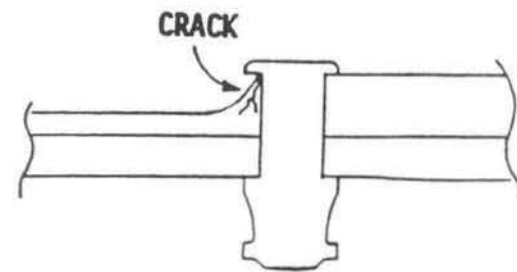

**CRACKS CAN FORM**

**AWARENESS BRIEFING**

## FASTENER HOLES MUST BE NORMAL TO THE HEAD SIDE SURFACE

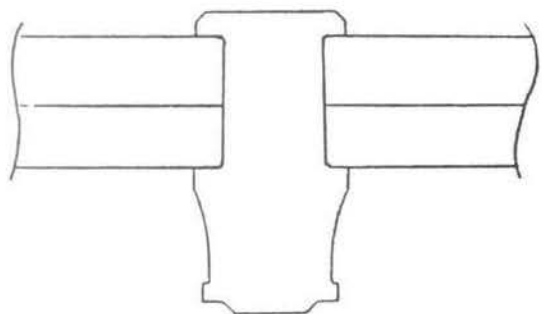

- GOOD
- NO PROBLEMS

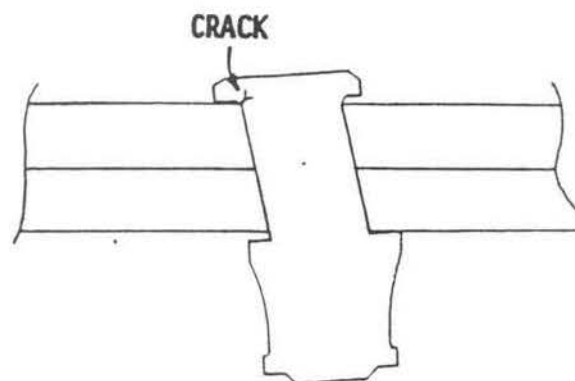

- HEAD TILT CAN CAUSE FATIGUE CRACKING
- STANDARD NUT/COLLAR WON'T TORQUE UP PROPERLY
  - THREADS DESTROYED

**SPOT FACE/RADIUS BLOCK  
MORE IMPORTANT THAN YOU MIGHT THINK**

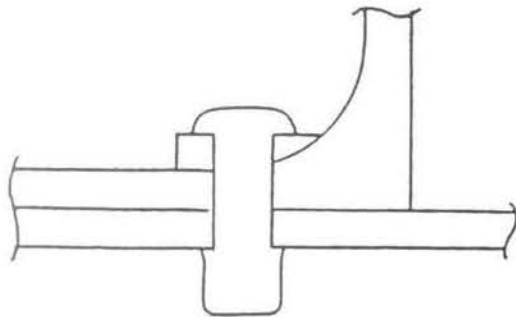
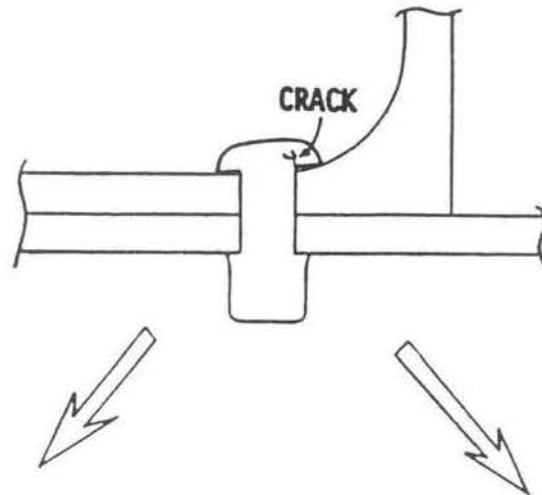

**RADIUS BLOCK SOLVES PROBLEM**

- MUST HAVE NEW LENGTH
- NEEDS ENGINEERING DISPOSITION

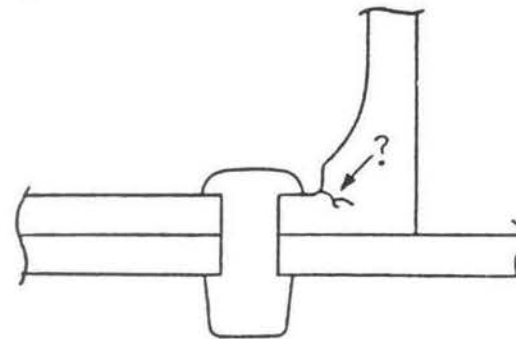

**SPOT FACE SOLVES PROBLEM**

- COULD CAUSE CRACKING IN HIGHLY LOADED PARTS
- NEEDS ENGINEERING DISPOSITION

**AWARENESS BRIEFING**

**THREADS IN STRUCTURE ARE UNACCEPTABLE**

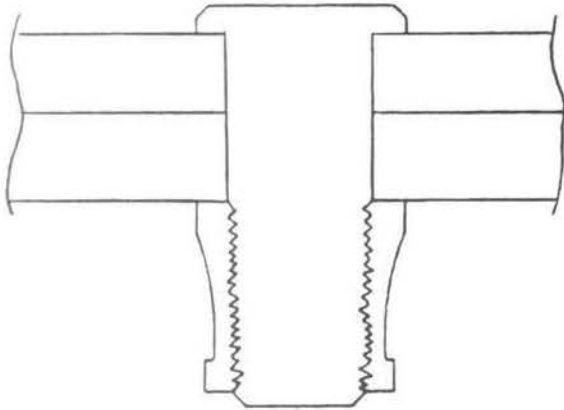

**GOOD - NO  
THREADS IN  
STRUCTURE**

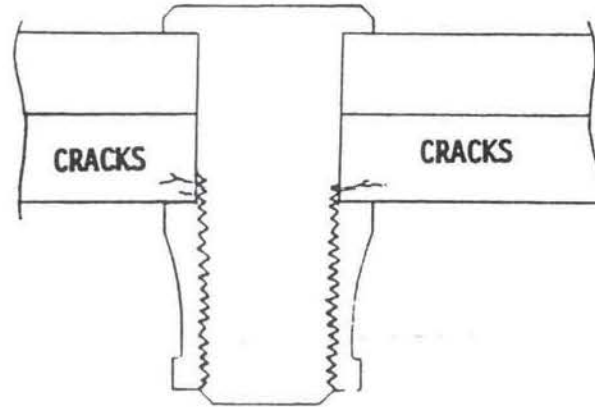

**UNACCEPTABLE -  
CRACKING CAN OCCUR  
WHERE THREAD  
CONTACTS STRUCTURE**

## FASTENER TORQUE

- A) WHEN A FASTENER IS TORQUED TOO MUCH, AN ADDITIONAL LOAD (THAT IT IS NOT SUPPOSED TO GET) IS FORCED INTO IT. THIS ADDITIONAL LOAD CAN MAKE IT FAIL OVER TIME.

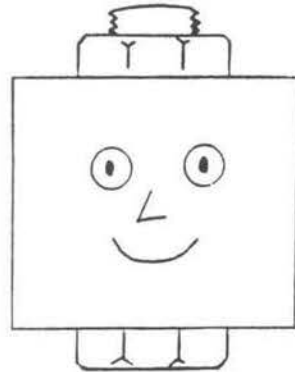

PROPERLY TORQUED

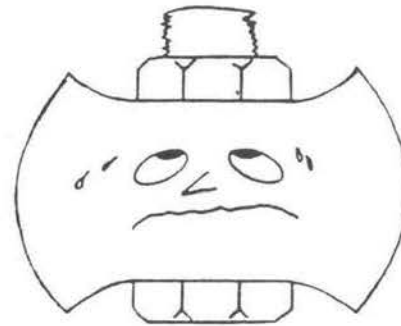

OVERTORQUED

- B) AN UNDERTORQUED FASTENER CAN ALSO CAUSE TROUBLE
- THE STRENGTH OF THE FASTENER IS SEVERELY DECREASED

**FASTENERS SHOULD NOT BE USED  
TO PULL OUT GAPS**

**AWARENESS BRIEFING**

## TENSION CAUSED BY PULLING OUT GAPS CAN CAUSE PROBLEMS

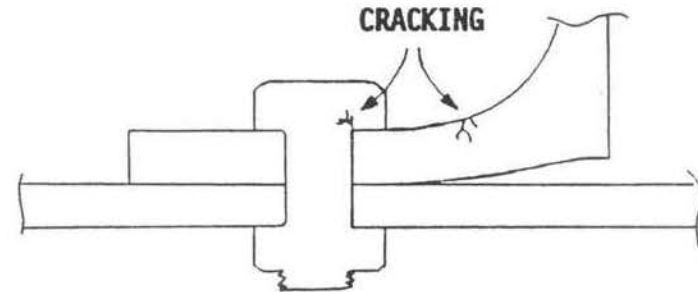
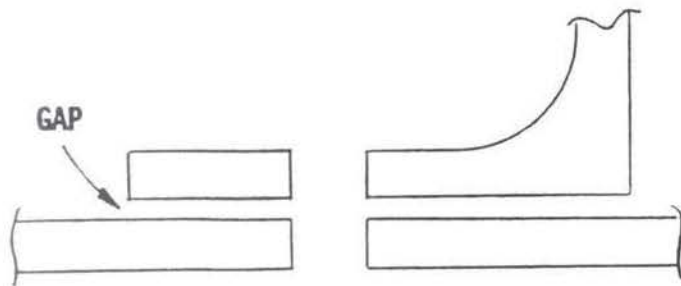

GAP EXIST

- PULL OUT GAP WITH FASTENER
- FATIGUE CRACKS CAN DEVELOP DUE TO TENSION IN FASTENER
- FASTENER WAS NOT INTENDED TO PULL OUT GAPS

AWARENESS BRIEFING



**DOUBLE DRIVING RIVETS IS RARELY ACCEPTABLE**

- 1) **DOUBLE DRIVING (TWO RIVET GUNS, NO BUCKING BAR - A REAL SHOCKER)**
  - A) **CAUSES CRACKING IN THE RIVETS**
  - B) **DAMAGES THE PARTS BEING RIVETED**
  - C) **MAY NOT FAIL UNTIL THE PLANE IS IN OPERATION**
  - D) **ACCEPTABLE ONLY BY ENGINEERING DISPOSITION**
  
- 2) **STANDARD DRIVING (ONE RIVET GUN, ONE BUCKING BAR)**
  - A) **REDUCES THE CHANCE OF THE ABOVE PROBLEMS**

TRIM EM WERMENT  
PB 10-573/PS 20028

- \* THE PROCESS BULLETIN OUTLINES THE REQUIREMENTS FOR TRIMMING SHEET METAL AND EXTRUDED METAL DETAIL PARTS TO PROVIDE COMPATIBLE FIT ON ON ASSEMBLY FOR THE F-15 ONLY.
- \* THE SPECIFICATION IS APPLICABLE TO SECONDARY STRUCTURE ONLY SUCH AS SHEET METAL WEBS OR SKINS AND FORMED SHEET METAL OR EXTRUDED PARTS.
- \* PARTS NOT CONSIDERED TO BE SECONDARY STRUCTURE ARE WING SPARS, MACHINED RIBS, MACHINED SKINS, BULKHEADS, MACHINED FORMERS, LONGERONS, STRINGERS, MACHINED FITTINGS, LANDING GEAR AND TRUNION BEAMS, STABILATOR TORQUE RIBS, SPINDLES, ETC.
- \* THE PROCESS BULLETIN IS NOT APPLICABLE TO INTERCHANGEABLE PARTS & IT CANNOT BE USED TO OBTAIN OPERATING CLEARANCE FOR CONTROLS MECHANISMS, TUBES, WIRE BUNDLES, ETC.

## TRIM EMPLOYMENT CONT'D

PB 10-573/PS 20028

### \* SPECIFICATION LIMITATIONS:

- o FASTENER PATTERNS DEFINED ON THE ENGINEERING DRAWING MUST NOT BE ALTERED.
- o MINIMUM EDGE DISTANCE REQUIREMENTS OF THE SPECIFICATION MUST BE MAINTAINED.
- o TRIMMING SHALL NOT REMOVE MORE THAN .060".
- o MATERIAL THICKNESS SHALL NOT BE REDUCED (EXCEPT FOR CHAMFERING).
- o MAINTAIN .50" MIN RADIUS ALONG TRIMMED EDGES.
- o IF TRIM EXTENDS THROUGH AN EXISTING RADIUS, MAINTAIN THE B/P RADIUS.
- o STIFFENING FLANGES SHALL NOT BE TRIMMED.

\* THE SURFACE TREATMENT MUST BE TOUCHED UP AFTER TRIMMING...  
ALODINE, PRIME, PAINT, ETC.

TRIM EMPLOYMENT CONT'D

PB 10-573/PS 20028

- \* ONE TIME TRIMS WITHIN THE GUIDELINES OF THE PROCESS BULLETIN DO NOT REQUIRE ANY TYPE OF DOCUMENTATION.
- \* REPETITIVE TRIMS (3 OR MORE OCCURRENCES) ARE TO BE DOCUMENTED ON THE F-15 PLANNING CALL SHEET (MDC FORM NO. 2099).
- \* LIAISON PLANNING AND A STRUCTURES ENGINEER WILL PERFORM AN INVESTIGATION OF THE TRIM INVESTIGATION REQUESTS NOTED ON THE PLANNING CALL SHEETS AND IF NECESSARY CAN TURN THE INVESTIGATION OVER TO THE PRODUCT TEAMS.
- \* CORRECTIVE ACTION CAN CONSIST OF INSTRUCTIONS TO CONTINUE TRIMMING (BY NOTE IN THE PLANNING ASSEMBLY ORDER), A TOOLING CHANGE, AN ENGINEERING ORDER, ETC.