



**SPIRIT™ Communication
System**

In Range-Out of Building
(IROB) Telephone
Installation Instructions

Model 371 Protector Assembly

Installation by Trained Technician Only

WARNING: Failure to follow these instructions could lead to personal injury and property damage. It will also void product warranties on all protected equipment.

Model 371 Protector Assembly consists of the following parts:
 Model 349-2LG MKII, Primary Protector
 Model 371-02, Secondary Protector
 Model 151, Faceplate Ground Adapter Screw

1. General

- These installation instructions cover the description and installation of the Model 371 Protector Assembly. The Model 371 is designed to protect both the control unit and the telephone sets of the **SPIRIT™** Communications System from foreign voltages caused by lightning, power contact, or power induction. Two (2) Model 371 Protector Assemblies are installed whenever the station is outside of the building but less than 1,000 feet from the **SPIRIT™** system control unit (Figure 1). The installation must follow requirements as outlined in Article 800-2 of the *National Electric Code Handbook*, and AT&T Standard Practice #462-005-100. Other AT&T Practices that describe wiring for a non-fused protector are identified in Section 6. (Section 6 also identifies how to order all of these documents.)
- The Model 371 Protector Assembly contains no field-serviceable components. If the protector must be replaced, the presence of hazardous voltages must be investigated *before touching any exposed metallic parts*.
- *Do not* connect grounds to the following:
 - Gas pipe
 - Electric service branch circuit conduit
 - Armor of BX cable
 - Interior of any electrical box

WARNING: Hazardous voltages may be present.

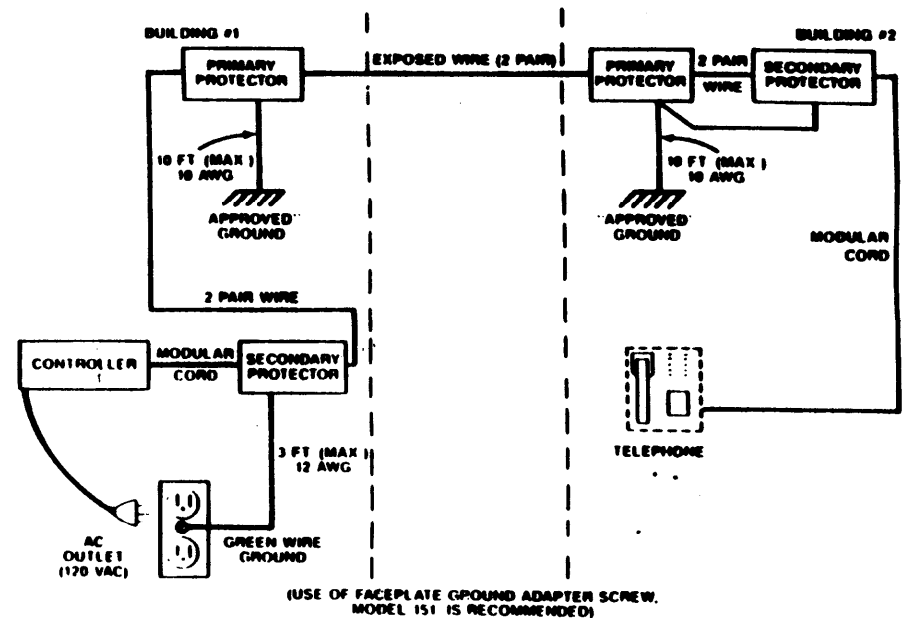

Figure 1
 SPIRIT™ CS IROB Installation

2. Description

The Model 371 IROB Protector Assembly is composed of a Model 349-2LG MKII Primary Protector, a Model 371-02 Secondary Protector, and a Model 151 Faceplate Ground Adapter Screw. Each protector is mounted in a separate housing with a hinged cover.

Primary Protector (Model 349-2LG MKII)

The housing includes a grommet for wire penetration, a No. 10 ground stud, and four (4) terminal posts.

The primary protection consists of two (2) TII 356L encapsulated, heavy duty three-electrode gas tube protector modules.

A tie wrap must be inserted through a tab on the hinged cover for security.

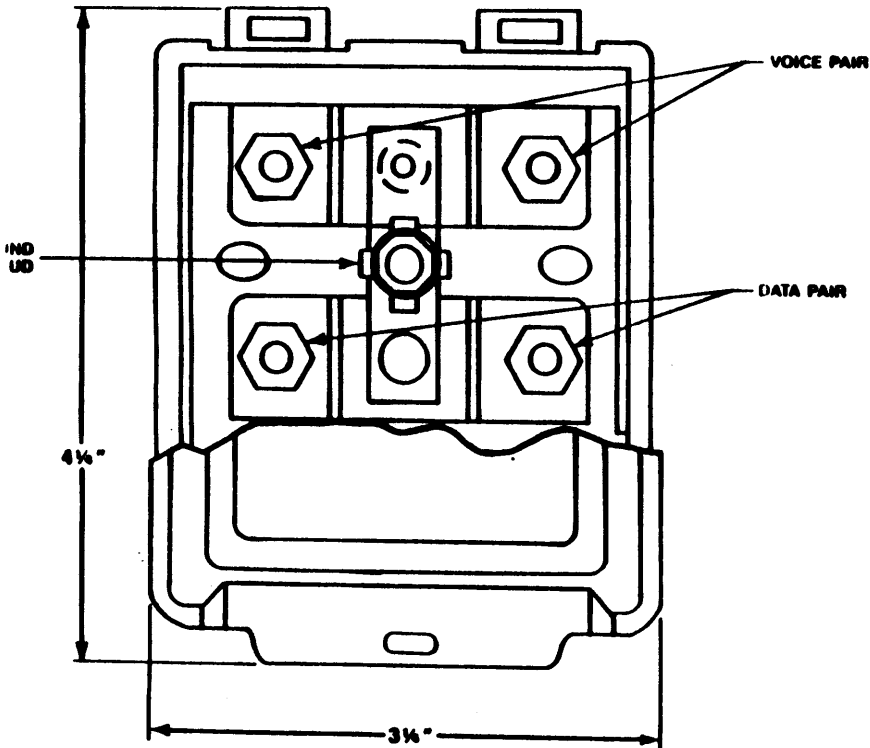

Figure 2A
Primary Protector (Model 349-2LG MKII)

2. Description (Cont'd)

Secondary Protector (Model 371-02)

- The housing includes four (4) screw terminals, a six-position modular jack, and a 3 ft. ground wire terminated in a spade lug.
- The secondary protection consists of solid-state surge suppression and fusing assembled on a printed wiring board.
- A tie wrap must be inserted through a tab on the hinged cover for security.

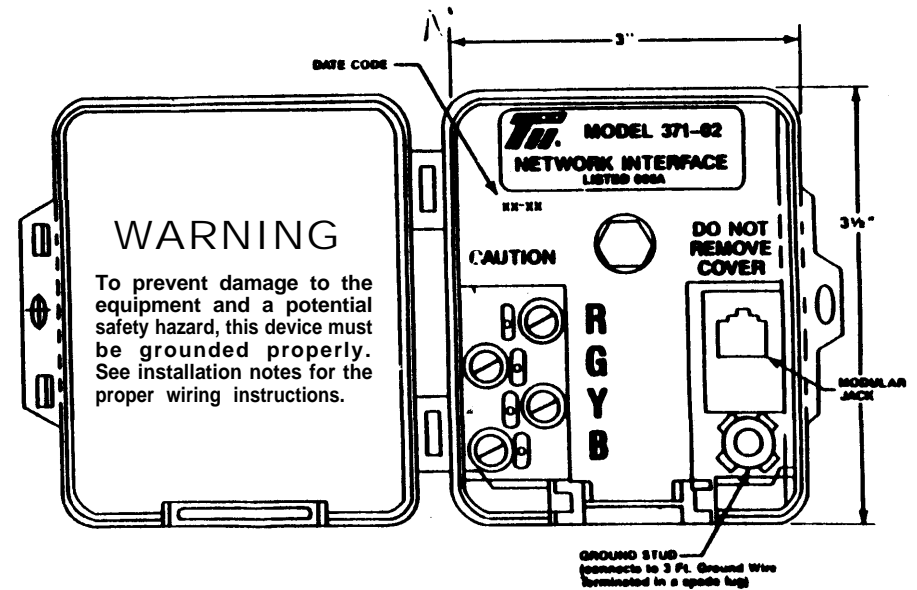

Figure 2B
Secondary Protector (Model 371-02)

3. Installation

Primary Protectors

- Two (2) Model 349-2LG MKII Primary Protectors are required for each IROB telephone. One is placed where the cable from the control unit leaves the building. The other is placed where the cable enters the building in which the IROB telephone is to be located. These units are intended for mounting in *indoor* locations only.
- An *approved* ground is required for proper operation of the IROB protector. An approved ground is an acceptable power service ground, grounded building concrete encased ground, or ring ground. The primary protector must be attached to an approved ground using No. 10 AWG copper wire or equivalent. See section 5 for the proper selection of an approved ground.

The wiring and grounding must follow requirements for a non-fused protector as outlined in Article 800-2 of the *National Electrical Code Handbook*, and AT&T Standard Practice #462-005-100. Other AT&T Practices that describe wiring for a non-fused protector are identified in Section 6.

- Prior to operation of the **SPiRiT™** system, the integrity of the local telephone company provided CO line protectors and grounding must be checked.

Verify that the local telephone company has done the following:

1. Equipped the CO
2. Grounded the CO protector ground lugs to an approved ground
3. Bonded the CO protector ground to the ground point used for the AC power service.

NOTE: Do not directly attach the primary protector to the ground lug of the protector block for the CO lines.

- The exposed wire facility serving the station and control unit should enter the building within 10 feet of an approved ground such as the AC power ground. The National Electrical Code requires that the protector be located in, or immediately adjacent to, the structure or building served, and as close as practicable to the point at which the exposed conductors enter or attach.
- Carefully unpack the protector, and select two of the four mounting holes.
- Place the unit, with cover down, on some protected surface and remove the flashing from selected holes with the blade of a screwdriver.
- With the door open, position the unit against the mounting surface, and mark the surface where the mounting holes are to be drilled.
- Lay the unit carefully aside, and drill lead holes in the mounting surface as marked. If the surface is masonry, use the appropriate hardware.
- Using No. 10 3/4" pan head screws, fasten the primary protector to the mounting surface.

3. Installation (Cont'd)

Secondary Protector (Model 371-02)

- In addition to the primary protectors, two (2) Model 371-02 Secondary Protectors are required for each, IROB telephone installation. One must be placed within 3 ft. of the control unit's AC power outlet. The placement of the other secondary protector is not as critical. It can be placed near the IROB telephone or near the primary protector located in the same building as the IROB telephone, whichever is more convenient for installation. These units are intended for mounting in indoor locations only.
- Carefully unpack the secondary protector.
- Remove the upper housing from the base. This is accomplished by opening the hinged cover which exposes a hexagonal head fastener. Turn the fastener counterclockwise until the upper housing separates from the base.
- Select two of the mounting holes on the base. Remove the flashing from the holes with the blade of a screwdriver.
- Position the base against the mounting surface, and mark the surface where the mounting holes are to be drilled.
- Lay the base aside and drill lead holes in the mounting surface as marked. If the surface is masonry, use the appropriate hardware.
- Using No. 10 3/4" pan head screws, fasten the base of the secondary protectors to the mounting surface.
- Reattach the upper housing to the base of the protector.

4. Wiring

Primary Protector (Model 349-2LG MKII)

- First, ground the protector by connecting a No. 10 AWG insulated solid copper wire to the ground stud of each protector. This can be done by stripping off approximately one inch of insulation and wrapping the bare wire around the ground stud under the washers and nut.
- Using appropriate fasteners, run the ground wire as straight as possible to the nearest approved ground. See section 3, paragraph 2 for a description of the approved ground. If a straight run is not possible, each bend must have a radius of at least nine inches.
- Secure the end of the ground wire to the approved ground using a recommended ground clamp and tag.
- Terminate the interbuilding wiring (22-24 AWG copper) on the terminal posts for each primary protector as shown in Figure 2A, making sure that separate pairs are used for the voice and data pair wiring.
- If the interbuilding wiring is exposed to the possibility of power cross, there must be a fusible link near the point of entrance. The fusible link can be a 2 foot (minimum) length of 26 AWG wire, under a metal enclosure or as part of a shielded cable. If the interbuilding wiring is a cable and the cable has a metallic shield, the shield must be bonded to the primary protector ground at both ends.

4. Wiring (Cont'd)

Secondary Protector (Model 371-02)

- The control unit's secondary protector must be connected to the green wire ground at the control unit's AC power outlet. Connect a 12 AWG insulated copper wire, not exceeding 3 ft. in length, from the ground stud of the secondary protector to the AC outlet's green wire ground.

NOTE: The 3 ft. limit is necessary for the proper protection of the control unit during a lightning surge.

NOTE: The recommended method for connecting to green wire ground at an AC outlet is to use the Faceplate Ground Adapter Screw, included with the Protector Assembly. This replaces the center screw of an AC outlet faceplate, providing secure attachment for a spade lug to green wire ground. Once installed, check the Faceplate Ground Adapter Screw for continuity to ground.

- The IROB telephone's secondary protector should be connected to the ground stud of the primary protector (located at the entrance of the building containing the IROB telephone). Another acceptable grounding point for this secondary protector, is the green wire ground at an AC outlet located near the IROB telephone. Connect a 12 AWG insulated copper wire from the secondary protector's ground stud (Figure 2B) to the chosen grounding point.
- The R and G screw terminals on the secondary protector (Figure 2B) are for the voice pair wiring, and the Y and B screw terminals are for the data pair wiring. Connect the voice pair and data pair wiring between the secondary and primary protectors, in each building. Reverse the data pair wires at the Y and B screw terminals of the IROB telephone's secondary protector. This preserves the polarity of the data signal. (The voice pair does not need to be reversed, since it is not polarity sensitive.)
- When the wiring of the secondary and primary protectors is complete, connect the control unit and IROB telephone to their respective secondary protectors using a four-conductor, six-position modular cord. Route the modular cord from the secondary protector's RJ11 jack through the opening below the hinged cover, and close the cover.
- When all work is complete, secure the secondary and primary protectors' covers with a tie wrap or a security wire.

5. Selection of an Approved Ground

- The first choice for approved ground is some part of the power grounding system (Figure 3). The National Electrical Code requires that the telephone and power grounds be bonded with No. 6 AWG copper wire or equivalent and that an accessible means be provided at the electrical service for bonding other systems, such as telephone systems, to the power. The bonding point means may consist of an accessible metallic service entrance conduit, a power grounding conductor (see the note below), or a connector located on the exterior of the power service raceway or power service equipment (circuit breaker panel).

NOTE: In some cases this may be a ground conductor from the interior of the circuit breaker panel which has been left accessible.

The approved ground should be installed according to NEC 800-2 and AT&T Practice #462-005-100.

6. References

National Electrical Code Handbook, 1984, published by the National Fire Protection Association.

AT&T Standard Practices. These are available from:

Support Services

AT&T

99 Jefferson Road

Room 2E09

Parsippany, New Jersey 07054

Telephone Number: 201-581-5685

Fax Number: 201-428-1878

AT&T Standard Practices include the following:

462-005-100, "Station Protection and Grounds"

676-300-100, "Electrical Protection — Stations and Customer Equipment"

518-010-105, "Key Telephone System, Ground and Special Protection

Requirements"

462-262-2xx (entire section of Practices), "Wiring at Terminals"

462-xxx-xxx (entire division), "Drop and Block Wiring"

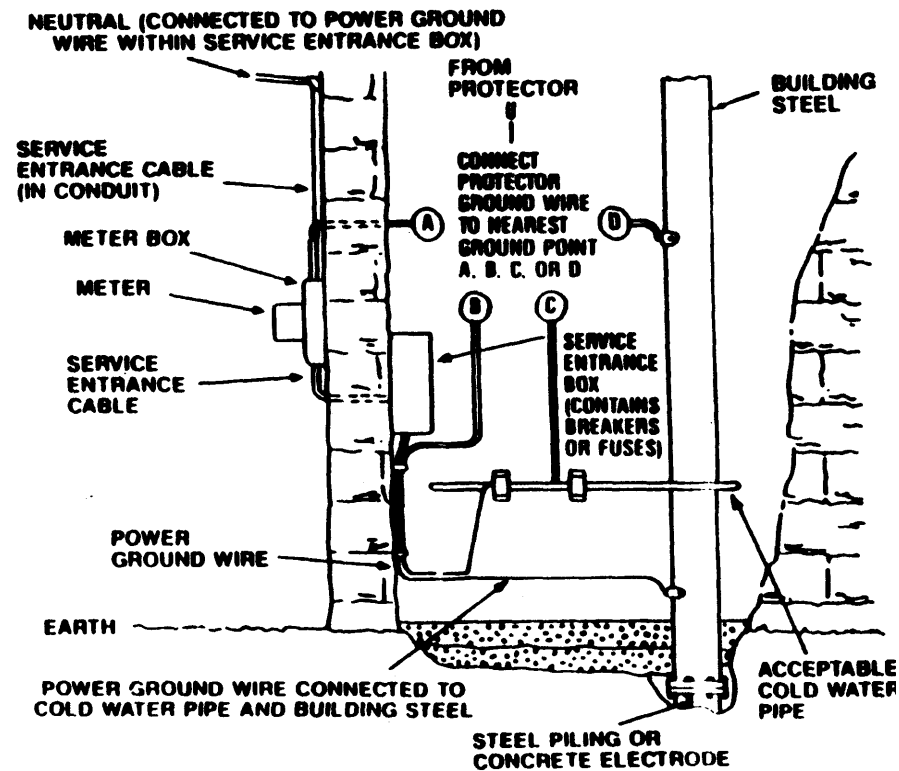

Figure 3
Grounding System