

Internal forces

■ Shear force

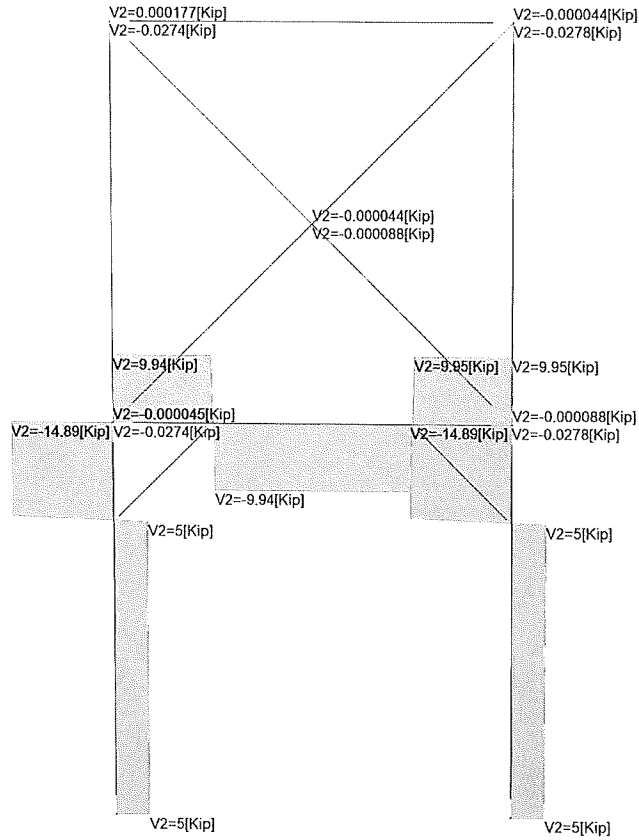

Internal forces
■ Bending moments

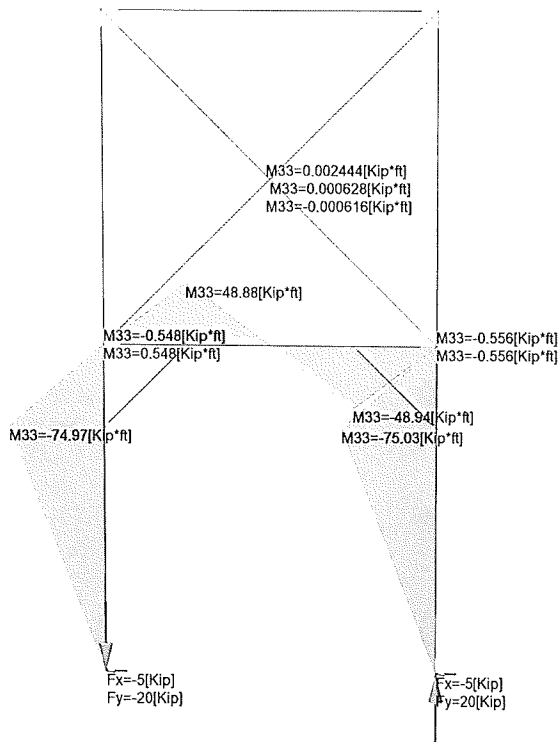

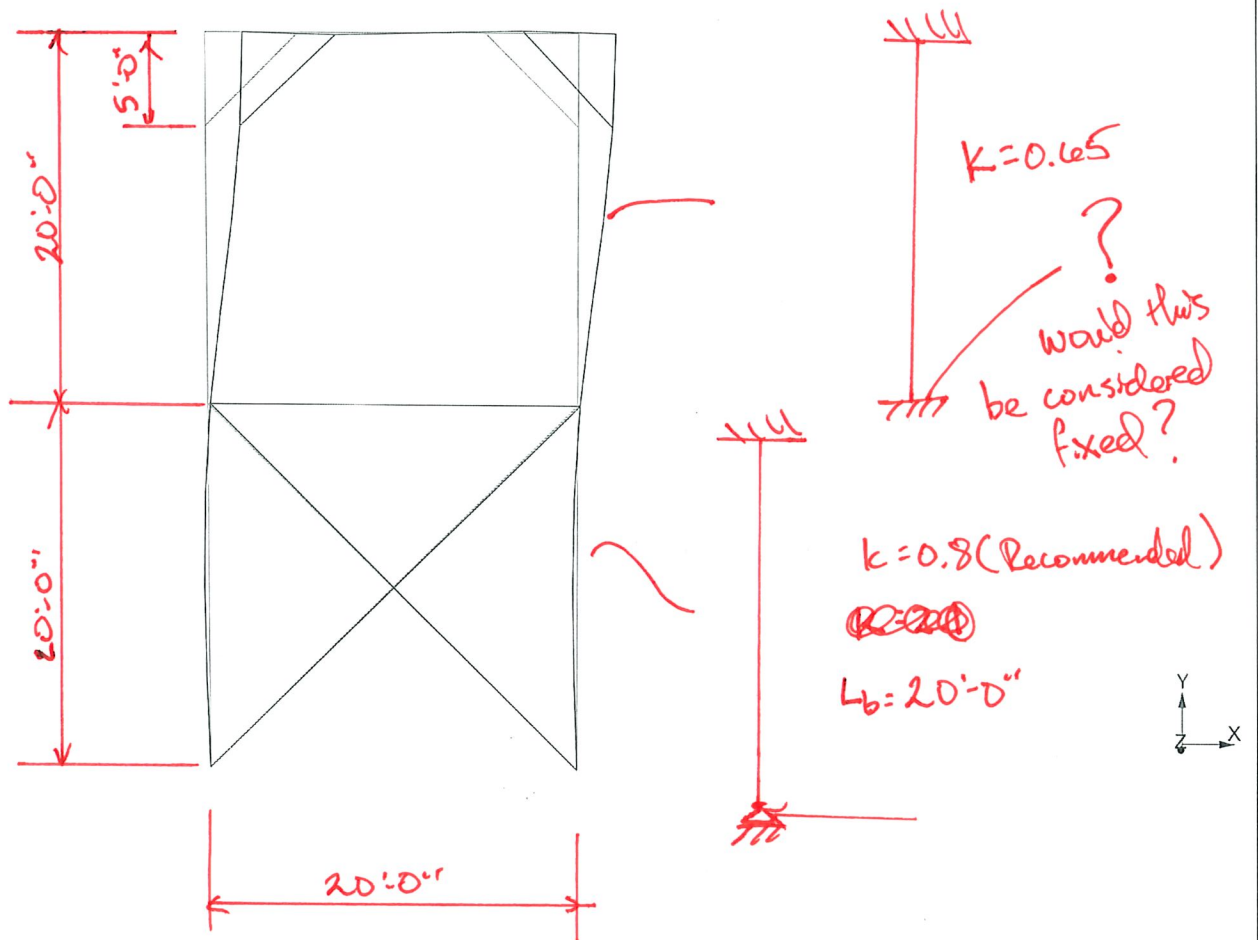

Internal forces

■ Axial force

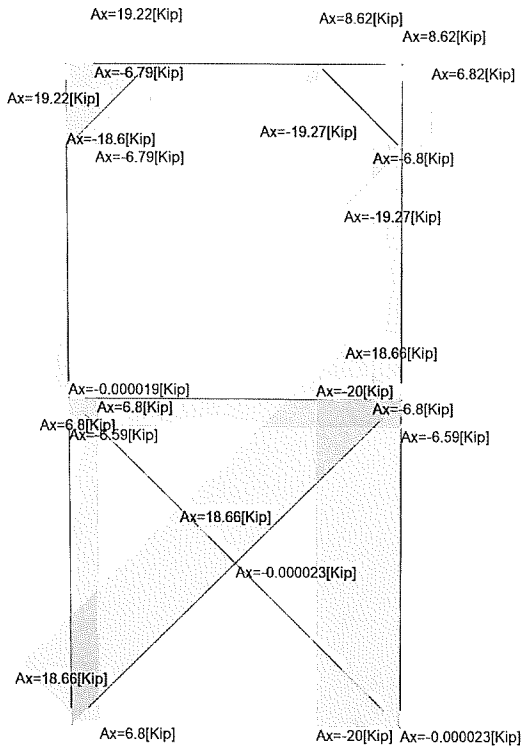

Internal forces

Shear force

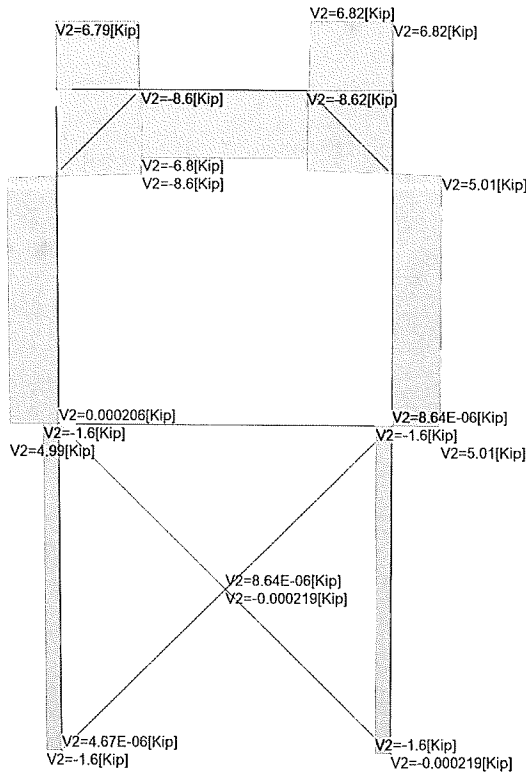

Internal forces
■ Bending moments

