



SIRIUS soft starter 200-480 V 143 A, 24 V AC/DC Screw terminals Analog output

<b>product brand name</b>	SIRIUS
<b>product category</b>	Hybrid switching devices
<b>product designation</b>	Soft starter
<b>product type designation</b>	3RW52
<b>manufacturer's article number</b>	<ul style="list-style-type: none"> <li>• of standard HMI module usable <a href="#">3RW5980-0HS00</a></li> <li>• of high feature HMI module usable <a href="#">3RW5980-0HF00</a></li> <li>• of communication module PROFINET standard usable <a href="#">3RW5980-0CS00</a></li> <li>• of communication module PROFIBUS usable <a href="#">3RW5980-0CP00</a></li> <li>• of communication module Modbus TCP usable <a href="#">3RW5980-0CT00</a></li> <li>• of communication module Modbus RTU usable <a href="#">3RW5980-0CR00</a></li> <li>• of communication module Ethernet/IP <a href="#">3RW5980-0CE00</a></li> <li>• of circuit breaker usable at 400 V <a href="#">3VA2220-7MN32-0AA0; Type of coordination 1, Iq = 65 kA, CLASS 10</a></li> <li>• of circuit breaker usable at 400 V at inside-delta circuit <a href="#">3VA2325-7MN32-0AA0; Type of coordination 1, Iq = 65 kA, CLASS 10</a></li> <li>• of the gG fuse usable up to 690 V <a href="#">3NA3244-6; Type of coordination 1, Iq = 65 kA</a></li> <li>• of the gG fuse usable at inside-delta circuit up to 500 V <a href="#">3NA3244-6; Type of coordination 1, Iq = 65 kA</a></li> <li>• of full range R fuse link for semiconductor protection usable up to 690 V <a href="#">3NE1227-0; Type of coordination 2, Iq = 65 kA</a></li> <li>• of back-up R fuse link for semiconductor protection usable up to 690 V <a href="#">3NE3334-0B; Type of coordination 2, Iq = 65 kA</a></li> </ul>
<b>General technical data</b>	
<b>starting voltage [%]</b>	30 ... 100 %
<b>stopping voltage [%]</b>	50 ... 50 %
<b>start-up ramp time of soft starter</b>	0 ... 20 s
<b>current limiting value [%] adjustable</b>	130 ... 700 %
<b>certificate of suitability</b>	
• CE marking	Yes
• UL approval	Yes
• CSA approval	Yes
<b>product component is supported</b>	
• HMI-Standard	Yes
• HMI-High Feature	Yes
<b>product feature integrated bypass contact system</b>	Yes
<b>number of controlled phases</b>	3
<b>trip class</b>	CLASS 10A (default) / 10E / 20E; acc. to IEC 60947-4-2
<b>buffering time in the event of power failure</b>	

<ul style="list-style-type: none"> <li>• for main current circuit</li> <li>• for control circuit</li> </ul>	100 ms
insulation voltage rated value	100 ms
<b>degree of pollution</b>	600 V
<b>impulse voltage rated value</b>	3, acc. to IEC 60947-4-2
<b>blocking voltage of the thyristor maximum</b>	6 kV
<b>service factor</b>	1 400 V
<b>surge voltage resistance rated value</b>	1
<b>maximum permissible voltage for safe isolation</b>	6 kV
<ul style="list-style-type: none"> <li>• between main and auxiliary circuit</li> </ul>	600 V
<b>utilization category acc. to IEC 60947-4-2</b>	AC 53a
<b>shock resistance</b>	15 g / 11 ms, from 12 g / 11 ms with potential contact lifting
<b>vibration resistance</b>	15 mm to 6 Hz; 2g to 500 Hz
<b>reference code acc. to IEC 81346-2</b>	Q
Substance Prohibitance (Date)	15.02.2018 00:00:00
<b>product function</b>	
<ul style="list-style-type: none"> <li>• ramp-up (soft starting)</li> <li>• ramp-down (soft stop)</li> <li>• Soft Torque</li> <li>• adjustable current limitation</li> <li>• pump ramp down</li> <li>• intrinsic device protection</li> <li>• motor overload protection</li> <li>• evaluation of thermistor motor protection</li> <li>• inside-delta circuit</li> <li>• auto-RESET</li> <li>• manual RESET</li> <li>• remote reset</li> <li>• communication function</li> <li>• operating measured value display</li> <li>• error logbook</li> <li>• via software parameterizable</li> <li>• via software configurable</li> <li>• <b>PROFInergy</b></li> <li>• <b>firmware update</b></li> <li>• <b>removable terminal for control circuit</b></li> <li>• torque control</li> <li>• analog output</li> </ul>	<p>Yes</p> <p>Yes</p> <p>Yes</p> <p>Yes</p> <p>Yes</p> <p>Yes</p> <p>Yes; Electronic motor overload protection</p> <p>No</p> <p>Yes</p> <p>Yes</p> <p>Yes</p> <p>Yes; By turning off the control supply voltage</p> <p>Yes</p> <p>Yes; Only in conjunction with special accessories</p> <p>Yes; Only in conjunction with special accessories</p> <p>No</p> <p>Yes</p> <p>Yes; in connection with the PROFINET Standard communication module</p> <p>Yes</p> <p>Yes</p> <p>No</p> <p>Yes; 4 ... 20 mA (default) / 0 ... 10 V (parameterizable with High Feature HMI)</p>
<b>Power Electronics</b>	
<b>operational current</b>	
<ul style="list-style-type: none"> <li>• at 40 °C rated value</li> <li>• at 50 °C rated value</li> <li>• at 60 °C rated value</li> </ul>	<p>143 A</p> <p>128 A</p> <p>118 A</p>
<b>operational current at inside-delta circuit</b>	
<ul style="list-style-type: none"> <li>• at 40 °C rated value</li> <li>• at 50 °C rated value</li> <li>• at 60 °C rated value</li> </ul>	<p>248 A</p> <p>222 A</p> <p>204 A</p>
<b>operating voltage</b>	
<ul style="list-style-type: none"> <li>• rated value</li> <li>• at inside-delta circuit rated value</li> </ul>	<p>200 ... 480 V</p> <p>200 ... 480 V</p>
<b>relative negative tolerance of the operating voltage</b>	-15 %
<b>relative positive tolerance of the operating voltage</b>	10 %
<b>relative negative tolerance of the operating voltage at inside-delta circuit</b>	-15 %
<b>relative positive tolerance of the operating voltage at inside-delta circuit</b>	10 %
<b>operating power for 3-phase motors</b>	

<ul style="list-style-type: none"> <li>• at 230 V at 40 °C rated value</li> </ul>	37 kW
<ul style="list-style-type: none"> <li>• at 230 V at inside-delta circuit at 40 °C rated value</li> </ul>	75 kW
<ul style="list-style-type: none"> <li>• at 400 V at 40 °C rated value</li> </ul>	75 kW
<ul style="list-style-type: none"> <li>• at 400 V at inside-delta circuit at 40 °C rated value</li> </ul>	132 kW
<b>Operating frequency 1 rated value</b>	50 Hz
<b>Operating frequency 2 rated value</b>	60 Hz
<b>relative negative tolerance of the operating frequency</b>	-10 %
<b>relative positive tolerance of the operating frequency</b>	10 %
<b>adjustable motor current</b>	
<ul style="list-style-type: none"> <li>• at rotary coding switch on switch position 1</li> </ul>	68 A
<ul style="list-style-type: none"> <li>• at rotary coding switch on switch position 2</li> </ul>	73 A
<ul style="list-style-type: none"> <li>• at rotary coding switch on switch position 3</li> </ul>	78 A
<ul style="list-style-type: none"> <li>• at rotary coding switch on switch position 4</li> </ul>	83 A
<ul style="list-style-type: none"> <li>• at rotary coding switch on switch position 5</li> </ul>	88 A
<ul style="list-style-type: none"> <li>• at rotary coding switch on switch position 6</li> </ul>	93 A
<ul style="list-style-type: none"> <li>• at rotary coding switch on switch position 7</li> </ul>	98 A
<ul style="list-style-type: none"> <li>• at rotary coding switch on switch position 8</li> </ul>	103 A
<ul style="list-style-type: none"> <li>• at rotary coding switch on switch position 9</li> </ul>	108 A
<ul style="list-style-type: none"> <li>• at rotary coding switch on switch position 10</li> </ul>	113 A
<ul style="list-style-type: none"> <li>• at rotary coding switch on switch position 11</li> </ul>	118 A
<ul style="list-style-type: none"> <li>• at rotary coding switch on switch position 12</li> </ul>	123 A
<ul style="list-style-type: none"> <li>• at rotary coding switch on switch position 13</li> </ul>	128 A
<ul style="list-style-type: none"> <li>• at rotary coding switch on switch position 14</li> </ul>	133 A
<ul style="list-style-type: none"> <li>• at rotary coding switch on switch position 15</li> </ul>	138 A
<ul style="list-style-type: none"> <li>• at rotary coding switch on switch position 16</li> </ul>	143 A
<ul style="list-style-type: none"> <li>• minimum</li> </ul>	68 A
<b>adjustable motor current</b>	
<ul style="list-style-type: none"> <li>• for inside-delta circuit at rotary coding switch on switch position 1</li> </ul>	118 A
<ul style="list-style-type: none"> <li>• for inside-delta circuit at rotary coding switch on switch position 2</li> </ul>	126 A
<ul style="list-style-type: none"> <li>• for inside-delta circuit at rotary coding switch on switch position 3</li> </ul>	135 A
<ul style="list-style-type: none"> <li>• for inside-delta circuit at rotary coding switch on switch position 4</li> </ul>	144 A
<ul style="list-style-type: none"> <li>• for inside-delta circuit at rotary coding switch on switch position 5</li> </ul>	152 A
<ul style="list-style-type: none"> <li>• for inside-delta circuit at rotary coding switch on switch position 6</li> </ul>	161 A
<ul style="list-style-type: none"> <li>• for inside-delta circuit at rotary coding switch on switch position 7</li> </ul>	170 A
<ul style="list-style-type: none"> <li>• for inside-delta circuit at rotary coding switch on switch position 8</li> </ul>	178 A
<ul style="list-style-type: none"> <li>• for inside-delta circuit at rotary coding switch on switch position 9</li> </ul>	187 A
<ul style="list-style-type: none"> <li>• for inside-delta circuit at rotary coding switch on switch position 10</li> </ul>	196 A
<ul style="list-style-type: none"> <li>• for inside-delta circuit at rotary coding switch on switch position 11</li> </ul>	204 A
<ul style="list-style-type: none"> <li>• for inside-delta circuit at rotary coding switch on switch position 12</li> </ul>	213 A
<ul style="list-style-type: none"> <li>• for inside-delta circuit at rotary coding switch on switch position 13</li> </ul>	222 A
<ul style="list-style-type: none"> <li>• for inside-delta circuit at rotary coding switch on switch position 14</li> </ul>	230 A
<ul style="list-style-type: none"> <li>• for inside-delta circuit at rotary coding switch on switch position 15</li> </ul>	239 A
<ul style="list-style-type: none"> <li>• for inside-delta circuit at rotary coding switch on switch position 16</li> </ul>	248 A
<ul style="list-style-type: none"> <li>• at inside-delta circuit minimum</li> </ul>	118 A
<b>minimum load [%]</b>	15 %; Relative to smallest settable le
<b>power loss [W] for rated value of the current at AC</b>	

<ul style="list-style-type: none"> <li>• at 40 °C after startup</li> <li>• at 50 °C after startup</li> <li>• at 60 °C after startup</li> </ul>	55 W 50 W 47 W
<b>power loss [W] at AC at current limitation 350 %</b>	
<ul style="list-style-type: none"> <li>• at 40 °C during startup</li> <li>• at 50 °C during startup</li> <li>• at 60 °C during startup</li> </ul>	2 127 W 1 807 W 1 605 W
<b>Control circuit/ Control</b>	
<b>type of voltage of the control supply voltage</b>	AC/DC
<ul style="list-style-type: none"> <li>• control supply voltage at AC at 50 Hz rated value</li> <li>• control supply voltage at AC at 60 Hz rated value</li> </ul>	24 V 24 V
<b>relative negative tolerance of the control supply voltage at AC at 50 Hz</b>	-20 %
<b>relative positive tolerance of the control supply voltage at AC at 50 Hz</b>	20 %
<b>relative negative tolerance of the control supply voltage at AC at 60 Hz</b>	-20 %
<b>relative positive tolerance of the control supply voltage at AC at 60 Hz</b>	20 %
<b>control supply voltage frequency</b>	50 ... 60 Hz
<b>relative negative tolerance of the control supply voltage frequency</b>	-10 %
<b>relative positive tolerance of the control supply voltage frequency</b>	10 %
<ul style="list-style-type: none"> <li>• control supply voltage at DC rated value</li> </ul>	24 V
<b>relative negative tolerance of the control supply voltage at DC</b>	-20 %
<b>relative positive tolerance of the control supply voltage at DC</b>	20 %
<b>control supply current in standby mode rated value</b>	160 mA
<b>holding current in bypass operation rated value</b>	380 mA
<b>locked-rotor current at close of bypass contact maximum</b>	7.6 A
inrush current peak at application of control supply voltage maximum	3.3 A
duration of inrush current peak at application of control supply voltage	12.1 ms
<b>design of the overvoltage protection</b>	Varistor
<b>design of short-circuit protection for control circuit</b>	4 A gG fuse (I <sub>cu</sub> =1 kA), 6 A quick-acting fuse (I <sub>cu</sub> =1 kA), C1 miniature circuit breaker (I <sub>cu</sub> = 600 A), C6 miniature circuit breaker (I <sub>cu</sub> = 300 A); Is not part of scope of supply
<b>Inputs/ Outputs</b>	
<b>number of digital inputs</b>	1
<b>number of inputs for thermistor connection</b>	0
<b>number of digital outputs</b>	3
<ul style="list-style-type: none"> <li>• not parameterizable</li> </ul>	2
<b>digital output version</b>	2 normally-open contacts (NO) / 1 changeover contact (CO)
<b>number of analog outputs</b>	1
<b>switching capacity current of the relay outputs</b>	
<ul style="list-style-type: none"> <li>• at AC-15 at 250 V rated value</li> <li>• at DC-13 at 24 V rated value</li> </ul>	3 A 1 A
<b>Installation/ mounting/ dimensions</b>	
<b>mounting position</b>	with vertical mounting surface +/-90° rotatable, with vertical mounting surface +/- 22.5° tiltable to the front and back
<b>fastening method</b>	screw fixing
<b>height</b>	306 mm
<b>width</b>	185 mm
<b>depth</b>	203 mm
required spacing with side-by-side mounting	
<ul style="list-style-type: none"> <li>• forwards</li> <li>• backwards</li> </ul>	10 mm 0 mm

<ul style="list-style-type: none"> <li>• upwards</li> <li>• downwards</li> <li>• at the side</li> </ul>	<p>100 mm</p> <p>75 mm</p> <p>5 mm</p>
<b>weight without packaging</b>	6.6 kg
<b>Connections/ Terminals</b>	
<b>type of electrical connection</b> <ul style="list-style-type: none"> <li>• for main current circuit</li> <li>• for control circuit</li> </ul>	<p>busbar connection</p> <p>screw-type terminals</p>
<b>width of connection bar maximum</b>	25 mm
<b>type of connectable conductor cross-sections</b> <ul style="list-style-type: none"> <li>• for DIN cable lug for main contacts stranded</li> <li>• for DIN cable lug for main contacts finely stranded</li> </ul>	<p>2x (16 ... 95 mm<sup>2</sup>)</p> <p>2x (25 ... 120 mm<sup>2</sup>)</p>
<b>type of connectable conductor cross-sections</b> <ul style="list-style-type: none"> <li>• for control circuit solid</li> <li>• for control circuit finely stranded with core end processing</li> <li>• at AWG cables for control circuit solid</li> </ul>	<p>1x (0.5 ... 4.0 mm<sup>2</sup>), 2x (0.5 ... 2.5 mm<sup>2</sup>)</p> <p>1x (0.5 ... 2.5 mm<sup>2</sup>), 2x (0.5 ... 1.5 mm<sup>2</sup>)</p> <p>1x (20 ... 12), 2x (20 ... 14)</p>
<b>wire length</b> <ul style="list-style-type: none"> <li>• between soft starter and motor maximum</li> <li>• at the digital inputs at AC maximum</li> <li>• at the digital inputs at DC maximum</li> </ul>	<p>800 m</p> <p>100 m</p> <p>1 000 m</p>
<b>tightening torque</b> <ul style="list-style-type: none"> <li>• for main contacts with screw-type terminals</li> <li>• for auxiliary and control contacts with screw-type terminals</li> </ul>	<p>10 ... 14 N·m</p> <p>0.8 ... 1.2 N·m</p>
<b>tightening torque [lbf·in]</b> <ul style="list-style-type: none"> <li>• for main contacts with screw-type terminals</li> <li>• for auxiliary and control contacts with screw-type terminals</li> </ul>	<p>89 ... 124 lbf·in</p> <p>7 ... 10.3 lbf·in</p>
<b>Ambient conditions</b>	
installation altitude at height above sea level maximum	5 000 m; Derating as of 1000 m, see catalog
<ul style="list-style-type: none"> <li>• ambient temperature during operation</li> <li>• ambient temperature during storage and transport</li> </ul>	<p>-25 ... +60 °C; Please observe derating at temperatures of 40 °C or above</p> <p>-40 ... +80 °C</p>
<b>environmental category</b> <ul style="list-style-type: none"> <li>• during operation acc. to IEC 60721</li> <li>• during storage acc. to IEC 60721</li> <li>• during transport acc. to IEC 60721</li> </ul>	<p>3K6 (no ice formation, only occasional condensation), 3C3 (no salt mist), 3S2 (sand must not get into the devices), 3M6</p> <p>1K6 (only occasional condensation), 1C2 (no salt mist), 1S2 (sand must not get inside the devices), 1M4</p> <p>2K2, 2C1, 2S1, 2M2 (max. fall height 0.3 m)</p>
<b>EMC emitted interference</b>	acc. to IEC 60947-4-2: Class A
<b>Communication/ Protocol</b>	
<b>communication module is supported</b> <ul style="list-style-type: none"> <li>• PROFINET standard</li> <li>• EtherNet/IP</li> <li>• Modbus RTU</li> <li>• Modbus TCP</li> <li>• PROFIBUS</li> </ul>	<p>Yes</p> <p>Yes</p> <p>Yes</p> <p>Yes</p> <p>Yes</p>
<b>UL/CSA ratings</b>	
<b>manufacturer's article number</b> <ul style="list-style-type: none"> <li>• of circuit breaker <ul style="list-style-type: none"> <li>— usable for Standard Faults at 460/480 V according to UL</li> <li>— usable for High Faults at 460/480 V according to UL</li> <li>— usable for Standard Faults at 460/480 V at inside-delta circuit according to UL</li> <li>— usable for High Faults at 460/480 V at inside-delta circuit according to UL</li> <li>— usable for Standard Faults at 575/600 V</li> </ul> </li> </ul>	<p>Siemens type: 3VA52, max. 250 A; I<sub>q</sub> = 10 kA</p> <p>Siemens type: 3VA52, max. 250 A; I<sub>q</sub> max = 65 kA</p> <p>Siemens type: 3VA52, max. 250 A; I<sub>q</sub> = 10 kA</p> <p>Siemens type: 3VA52, max. 250 A; I<sub>q</sub> max = 65 kA</p> <p>Siemens type: 3VA52, max. 250 A; I<sub>q</sub> = 10 kA</p>

according to UL

— usable for Standard Faults at 575/600 V at inside-delta circuit according to UL

• of the fuse

— usable for Standard Faults up to 575/600 V according to UL

— usable for High Faults up to 575/600 V according to UL

— usable for Standard Faults at inside-delta circuit up to 575/600 V according to UL

— usable for High Faults at inside-delta circuit up to 575/600 V according to UL

Siemens type: 3VA52, max. 250 A; I<sub>q</sub> = 10 kA

Type: Class RK5 / K5, max. 350 A; I<sub>q</sub> = 10 kA

Type: Class J / L, max. 350 A; I<sub>q</sub> = 100 kA

Type: Class RK5 / K5, max. 350 A; I<sub>q</sub> = 10 kA

Type: Class J / L, max. 350 A; I<sub>q</sub> = 100 kA

**operating power [hp] for 3-phase motors**

- at 200/208 V at 50 °C rated value
- at 220/230 V at 50 °C rated value
- at 460/480 V at 50 °C rated value
- at 200/208 V at inside-delta circuit at 50 °C rated value
- at 220/230 V at inside-delta circuit at 50 °C rated value
- at 460/480 V at inside-delta circuit at 50 °C rated value

40 hp

40 hp

100 hp

75 hp

75 hp

150 hp

**contact rating of auxiliary contacts according to UL**

R300-B300

**Safety related data**

**protection class IP on the front acc. to IEC 60529**

IP00; IP20 with cover

**touch protection on the front acc. to IEC 60529**

finger-safe, for vertical contact from the front with cover

**electromagnetic compatibility**

in accordance with IEC 60947-4-2

**Certificates/ approvals**

**General Product Approval**

**EMC**

**Declaration of Conformity**



[Miscellaneous](#)

**Declaration of Conformity**

**Test Certificates**

**Marine / Shipping**



[Type Test Certificates/Test Report](#)



**other**

[Confirmation](#)

**Further information**

**Information- and Downloadcenter (Catalogs, Brochures,...)**

<https://www.siemens.com/ic10>

**Industry Mall (Online ordering system)**

<https://mall.industry.siemens.com/mall/en/en/Catalog/product?mfb=3RW5235-6AC04>

**Cax online generator**

<http://support.automation.siemens.com/WW/CAXorder/default.aspx?lang=en&mfb=3RW5235-6AC04>

**Service&Support (Manuals, Certificates, Characteristics, FAQs,...)**

<https://support.industry.siemens.com/cs/ww/en/ps/3RW5235-6AC04>

Image database (product images, 2D dimension drawings, 3D models, device circuit diagrams, EPLAN macros, ...)

[http://www.automation.siemens.com/bilddb/cax\\_de.aspx?mlfb=3RW5235-6AC04&lang=en](http://www.automation.siemens.com/bilddb/cax_de.aspx?mlfb=3RW5235-6AC04&lang=en)

Characteristic: Tripping characteristics, I<sub>t</sub>, Let-through current

<https://support.industry.siemens.com/cs/ww/en/ps/3RW5235-6AC04/char>

Characteristic: Installation altitude

<http://www.automation.siemens.com/bilddb/index.aspx?view=Search&mlfb=3RW5235-6AC04&objecttype=14&gridview=view1>

Simulation Tool for Soft Starters (STS)

<https://support.industry.siemens.com/cs/ww/en/view/101494917>

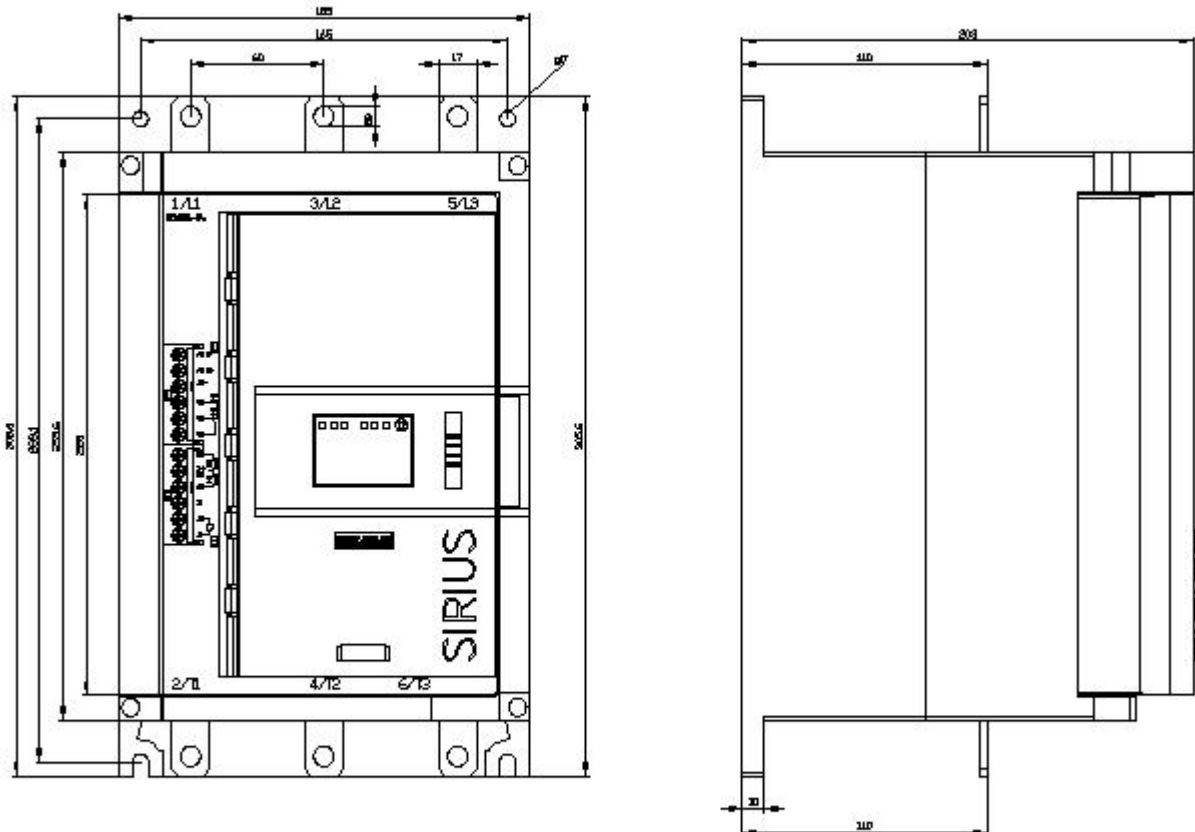

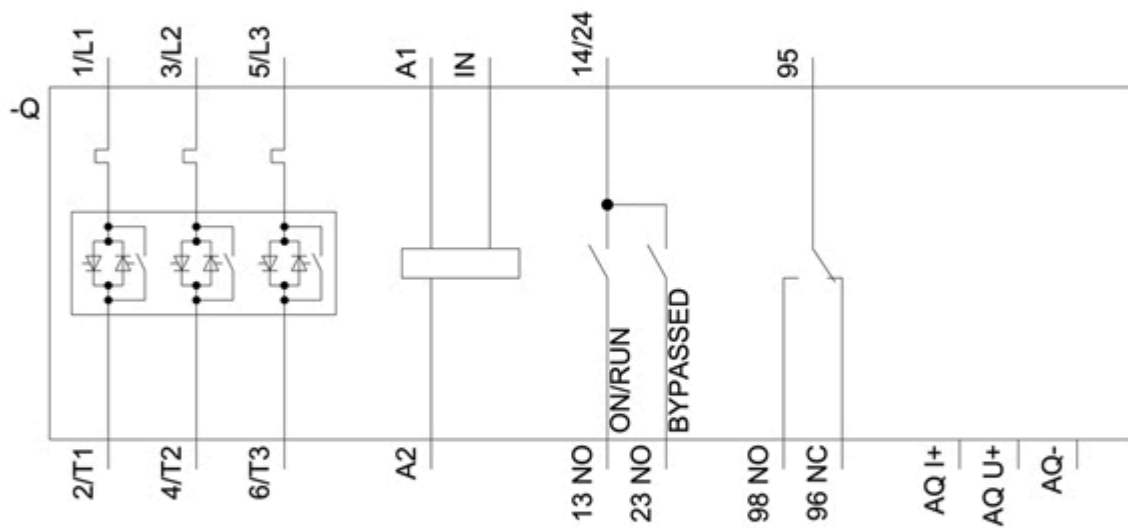

last modified:

12/15/2020 