

AMERICAN NATIONAL STANDARD

ANSI/NAAMM

AMP 521 **-01 (R2012)**

ARCHITECTURAL METAL PRODUCTS



ANSI/NAAMM AMP 521-01 (R2012)
February 23, 2012

PIPE RAILING
SYSTEMS MANUAL
Including Round Tube
Fourth Edition

ANSI/NAAMM AMP 521-01 (R2012)
February 23, 2012



ARCHITECTURAL METAL PRODUCTS

AMP Architectural Metal Products

A Division of

NAAMM

NATIONAL ASSOCIATION OF
ARCHITECTURAL METAL MANUFACTURERS

PIPE RAILING SYSTEMS MANUAL

Including Round Tube

Fourth Edition

ANSI/NAAMM AMP 521-01
(R2012)

Published and distributed by the

NATIONAL ASSOCIATION OF ARCHITECTURAL METAL MANUFACTURERS

800 Roosevelt Road
Building C, Suite 312
Glen Ellyn, IL 60137

Approval of an American National Standard requires verification by ANSI that the requirements for due process, consensus, and other criteria for approval have been met by the standards developer.

Consensus is established when, in the judgment of the ANSI Board of Standards Review, substantial agreement has been reached by directly and materially affected interests. Substantial agreement means much more than a simple majority, but not necessarily unanimity. Consensus requires that all views and objections be considered, and that a concerted effort be made toward their resolution.

The use of American National Standards is completely voluntary; their existence does not in any respect preclude anyone, whether he has approved the standards or not, from manufacturing, marketing, purchasing, or using products, processes, or procedures not conforming to the standards.

The American National Standards Institute does not develop standards and will in no circumstances give an interpretation of any American National Standard. Moreover, no person shall have the right or authority to issue an interpretation of an American National Standard in the name of the American National Standards Institute. Requests for interpretation should be addressed to the sponsor whose name appears on the title page of this standard.

CAUTION NOTICE: This American National Standard may be revised or withdrawn at any time. The procedures of the American National Standards Institute require that action be taken periodically to reaffirm, revise, or withdraw this standard. Purchasers of American National Standards may receive current information on all standards by calling or writing the American National Standards Institute.

This standard was developed by the National Association of Architectural Metal Manufacturers (NAAMM) to provide guidance on the specification and use of pipe railing systems. This standard contains advisory information only and is published as a public service by NAAMM. NAAMM disclaims all liability of any kind for the use, application, or adaptation of material published in this standard.

Current information on all NAAMM Standards is available by calling or writing the National Association of Architectural Metal Manufacturers or by going to www.naamm.org.

TABLE OF CONTENTS

| | |
|--|----|
| Introduction | 2 |
| Railing System Materials..... | 3 |
| Construction Details | 7 |
| Structural Design | 13 |
| Installation and Anchorage | 25 |
| Pipe and Tube Dimensions and Properties..... | 27 |
| Guide Specifications | 29 |
| Glossary of Terms | 43 |

INTRODUCTION

This Fourth Edition of the Pipe Railing Systems Manual has been prepared by NAAMM to provide engineers, architects, and specification writers, as well as other concerned members of the construction team, with information on pipe railing systems, which includes:

- up-to-date data on the materials appropriate for use in pipe railing systems,
- guidance in their structural design under current regulations,
- graphic representations of some commonly used construction details,
- information and suggestions on installation and anchorage, and
- specification guidelines.

Metric equivalents are included as an aid to the Manual's user. The system of metric measurement used follows IEEE/ASTM SI 10-1997, "Standard for Use of the International System of Units (SI): (The Modern Metric System)". Values are presented in both inch-pound and SI units. The values stated in inch-pounds are to be regarded as the standard.

The information provided represents recommendations from manufacturers of pipe railing systems and/or suppliers of component parts. The Manual was developed by technical representatives from these companies. The terminology used reflects agreement with the Glossary and ASTM E 1481, Terminology of Railing Systems and Rails for Buildings.

The task of designing a simple hand rail becomes less simple with the proliferation of governmental regulations, such as OSHA and ADA. It can be further complicated by revisions to the model codes, the development of new international codes, as well as changes to ASCE, ANSI, ASTM and other standards. The designer is faced with the continuing task of interpreting these documents and applying them to specific applications. Having determined which regulations and code requirements are applicable to his specific site, the designer must then determine the sizes and dimensions of the railing system that will meet the specified loads for the required service conditions. NAAMM, recognizing that the simple design may not be so simple, is determined to provide as much assistance to this process as possible short of actually designing the railing systems.

Prior to the development and publication of the *"Pipe Railing Systems Manual"* by NAAMM, information about the design of railing systems was limited to literature developed by manufacturers of these systems and the suppliers of components. The three previous editions of this manual have been accepted widely as authoritative additions to this literature. NAAMM's primary objective is to encourage efficient designs that comply with recognized standards of performance for all architectural metal work. The publication of the Fourth Edition represents NAAMM's continued efforts toward that goal.

RAILING SYSTEM MATERIALS

Steel

There are several pipe and tubing material specifications available for steel pipe railing systems. These include ASTM A 53, A 500, and A 501, as well as several proprietary designations. In addition to strength considerations, methods of fabrication, and code regulations, the availability of material determines which type and grade to use.

ASTM A 53 specification requires tensile, bend and flattening tests, as well as pressure testing, but the latter is not required for railing system pipe. Mechanical properties, but no pressure tests, are specified for ASTM A 500 and A 501. Pipe sizes are given in nominal Iron Pipe Size (IPS) dimensions and schedules, so that the actual outside diameter (OD) is greater than the nominal IPS. Tubing sizes are given in actual OD and wall thickness. It is necessary to distinguish between pipe and tubing when specifying size.

Connections in architectural railing systems are made by welding unless designated otherwise. All types and grades of pipe and tubing covered by ASTM A 53, A 500 and A 501 are weldable.

With the allowable size openings in a guardrail system becoming more restrictive, fabrication has become more labor intensive. A significant percentage of the cost in fabricating a railing system involves the grinding and sanding necessary to dress each joint.

Note: When ordering ASTM A 513, it is necessary to stipulate mechanical properties desired.

Depending upon the usage of the railing system, the desired appearance of the joints varies considerably. For example, a utilitarian railing system in an industrial setting does not need the same finished appearance as a railing system in a public building.

To assist a designer in selecting the most economical railing system for a specific application, four types of joint construction are shown on page 7. Type 1 is the most costly to produce, and Type 4 is the least costly. The accompanying photographs show how each of the four types appear with a prime coat of paint applied.

Architectural steel pipe railing systems are either finished by painting in the field, over a shop applied prime coat, or galvanized. Pipe and tubing are supplied with either a black or galvanized finish. Under current regulations for workers' protection, field galvanizing is impractical. When a galvanized railing system is required, the choices are either hot-dip galvanizing after fabrication - an expensive operation with definite size limitations - or the use of galvanized pipe with zinc-rich paint being applied over welds and abrasions.

Note: For additional information, refer to NAAMM Metal Finishes Manual, AMP 504-88 "Finishes for Carbon Steel and Iron".

RAILING SYSTEM MATERIALS

Aluminum

Extruded pipe and extruded or drawn tube are available in aluminum and are used in railing systems.

The main difference in pipe and tube is in their dimensional tolerances and surface qualities. For welded pipe railing systems, pipe tolerances are acceptable and surface quality is not always an important factor. For railing systems using flush type fittings and assembled mechanically, tube tolerance or better is required to produce tight and smooth joints. Material for such railing systems is tube-quality handrail pipe, extruded or drawn. Tube-quality pipe is also used where an etched, anodized or polished finish has to be produced. Drawn pipe or tube has closer dimensional tolerances and smoother surface than extruded pipe or tube. Drawn material develops its increased strength by work hardening.

Extruded pipe or tube is specified to either ASTM B 429, Specification for Aluminum and Aluminum-Alloy Extruded Structural Pipe and Tube, or ASTM B 221 (B 221M) Specification for Aluminum and Aluminum-Alloy Extruded Bars, Rods, Wires, Shapes, and Tubes.

Drawn tube is specified to either ASTM B 483 (B 483M), Specification for Aluminum and Aluminum-Alloy Drawn Tubes for General Purpose Applications, or ASTM B 210 (B 210M), Specification for Aluminum and Aluminum-Alloy Drawn Seamless Tubes.

Alloy 6063-T52 is used in railing systems and can be bent without heating. Alloy 6063-T832 has the smoothest surface and the best dimensional accuracy of any of the available aluminum materials and is suitable for clear anodizing without discoloration. Alloy 6061-T6 has the same high strength as 6063-T832 at less cost, but is not as suitable for bending and has a yellowish tint when anodized.

Nominal pipe sizes are 1¼” and 1½” (NPS), Schedules 10 and 40, with nominal OD of 1.660 in. (42.2 mm) and 1.900 in. (48.3 mm). Tube sizes are denoted by OD of 1.5 in. (38.1 mm) and 2.0 in. (50.8 mm) and wall thickness of 0.125 in. (3.18 mm), 0.188 in. (4.78 mm), and 0.250 in. (6.35 mm).

Railing system connections are made by bending, by mitering and welding, or by using standard fittings. Many non-welded mechanical systems are available and being used.

Some mechanical systems are assembled with adhesives or with metal fasteners. When systems are assembled by welding, Alloy 5356 filler wire is used to minimize discoloration if the assembly is to be anodized. Either Alloy 4043 or Alloy 5356 filler wire is used for mill finish or organic coatings but Alloy 4043 is not recommended for anodizing. Where appearance is important, welds are ground, polished and blended; otherwise, as in structural applications, they are left untouched. It must be remembered that welding removes temper and reduces strength within 1” (25.4 mm) of a weld.

For both interior and exterior railing systems, mill finishes followed by anodizing are used if specified. Anodizing is available in clear and colored finishes, bronze being the color generally used. These anodized finishes provide attractive, durable and weather resistant surfaces. Architectural Class I finish, which has a minimum anodic coating thickness of 0.7 mills, and Architectural Class II finish, which has a minimum anodic coating thickness of 0.4 mills, are used on railing systems. Architectural Class I is for the more severe exposures and use. The Aluminum Association designations for three types of anodic coatings for architectural work are listed below:

| <u>Type of Anodic Coating</u> | <u>AA Designations</u> | |
|---|------------------------|-----------------|
| | <u>Class I</u> | <u>Class II</u> |
| Clear (Natural) Anodized | A41 | A31 |
| Integral Color Anodized | A42 | A32 |
| Electrolytically Deposited Color Anodized | A44 | A34 |

As discussed on page 3, the most economical railing system joint design is obtained when selection is based on the specific application. While only prime painted steel pipe joints are shown on page 7, the written description for each type is still considered applicable.

Organic coatings used on railing systems, like anodized finishes, require a minimum of maintenance. For interior applications, railing systems, etched and lacquered or waxed, require regular maintenance to preserve the surface protection and appearance.

Note: For additional information, refer to NAAMM Métal Finishes Manual, AMP 501-88 “Finishes for Aluminum”.

Copper Alloys

“Bronze” pipe railing systems are fabricated from drawn, seamless red brass (Alloy C23000) pipe. This alloy contains nominally 85% copper, 15% zinc, and conforms to ASTM B 43. Such pipe is available in Schedule 40 and Schedule 80 sizes. For architectural applications it is supplied in special untrade-marked 20-foot (6 m) lengths instead of the standard 12-foot (3.7 m) lengths with markings of size, weight and manufacturer along each length.

Architectural bronze (Alloy C38500) conforming to ASTM B 455 is used for bars, standard shapes and special shapes such as handrail moldings.

Alloy C23000 pipe in the standard light annealed temper is bent to the radii normally used in railing system construction. Returns and offsets are provided by mitering and welding or by the use of flush fittings. In standard pipe sizes, Alloy C23000 pipe is compatible with standard cast fittings. Leaded red brass (Alloy C83600) is specified for sand castings. This alloy, also identified as ingot No. 115 and conforming to ASTM B 62 and B 584, has nominal composition of 85% copper, 5% lead, 5% tin and 5% zinc.

Pipe is pre-finished before fabricating. Finishes are either satin or brushed (directional textured) and are achieved through the use, either singly or progressively, of No. 80, 180 and 220 grit abrasive. Following pre-finishing, the pipe is covered with strippable tape, a spray-applied strippable coating,

or other suitable means, for protection during fabricating operations. After assembly, the protective covering is removed, and the completed railing system is given its final finish.

As discussed on page 3, the most economical railing system joint design is obtained when selection is based on the specific application. While only prime painted steel joints are shown on page 7, the written description for each type is still considered applicable.

The natural golden color of Alloy C23000 normally darkens by oxidation upon exposure to the atmosphere. To protect the natural color, immediately following mechanical finishing the completed railing system sections are coated with acrylic or clear lacquer. “Incralac” is a clear lacquer developed by the International Copper Research Association specifically for use on copper alloys. The Copper Development Association has information on this type of coating. Wax is used to protect the natural color. The natural weathering process is accelerated by chemical conversion treatments. Of these treatments, the aqueous sulfide solutions, which produce the “statuary bronze” finishes, are most common for railing systems.

Note: For additional information, refer to NAAMM Metal Finishes Manual, AMP 502-88 “Finishes for the Copper Alloys”.

Stainless Steel

Stainless steels are a family of corrosion and heat resistant iron-based alloys containing a minimum of about 16% chromium, along with nickel and other alloying elements. They are divided into three groups according to composition and metallurgical characteristics, the alloys in each group being identified by a numbering system established by the American Iron and Steel Institute. Those in the austenitic group have numbers in the 200's and 300's; those in the ferritic and martensitic groups, numbers in the 400's.

Types of stainless steel used for railing systems and other architectural applications are austenitic Grades 304 and 316. They are nonmagnetic and cannot be hardened by heat treatment, but can be hardened by cold working. Both grades are available in both pipe and tubing, as well as in castings for use as anchors and other railing system components. The casting alloy is identified by the Alloy Casting Institute as CF-8. Since sand castings are very rough and expensive to finish, machined or formed fittings shall be used when available.

The most economical form of stainless steel for railing systems is welded tubing, which is used in the "as-welded" condition for structural or ornamental applications only, and is not annealed, pickled or pressure-tested. This product, ASTM A 554, "Welded Stainless Steel Mechanical Tubing" is available in the same outside diameters as stainless steel pipe, but at lower cost.

The mechanical properties of stainless steel vary widely, depending on the degree of cold working to which it is subjected. Minimum yield strength is 30,000 psi (205 MPa) for annealed tubing but is greater for unannealed "as-welded" tubing.

As discussed on page 3, the most economical railing system joint design is obtained when selection is based on the specific application. While only prime painted steel joints are shown on page 7, the written description for each type is still considered applicable.

Care must be taken in fabricating, finishing and maintaining stainless steel to avoid contamination. Grease, dirt, and other foreign matter are some of the sources of discoloration under the effects of weathering. Even the use of ordinary steel wool instead of stainless steel wool can leave minute carbon steel particles which will cause rust stains.

Tubing is available in several finishes, including non-reflective mill finish, bright annealed and various polished finishes. Used extensively is No. 4, a general purpose bright polished finish available from most suppliers. It has the advantage of being easily matched in either shop or field work which facilitates finish blending after welding or removal of surface blemishes.

Note: For additional information, refer to NAAMM Metal Finishes Manual, AMP 503-88 "Finishes for Stainless Steel".

Railing System Joint Construction

Welded Steel Pipe or Tubing with Prime Coat of Paint Applied

- Type 1 — Ornamental quality —
used where appearance is a critical factor
- Type 2 — Weld of good appearance used in areas of traffic —
where highly ornamental quality is not required
- Type 3 — Used in areas where it is not subject to view —
as in service stairs
- Type 4 — Acceptable when appearance is not a factor —
used in industrial and non-public areas

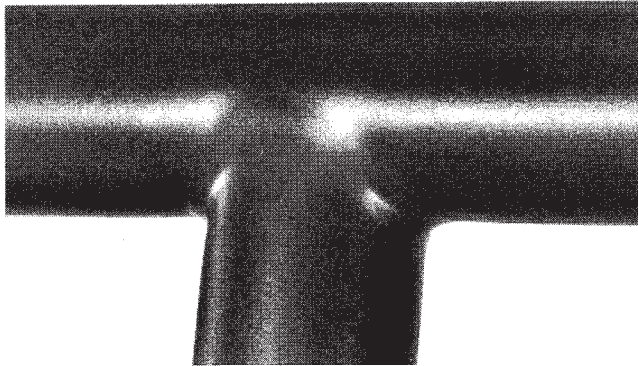

Type 1

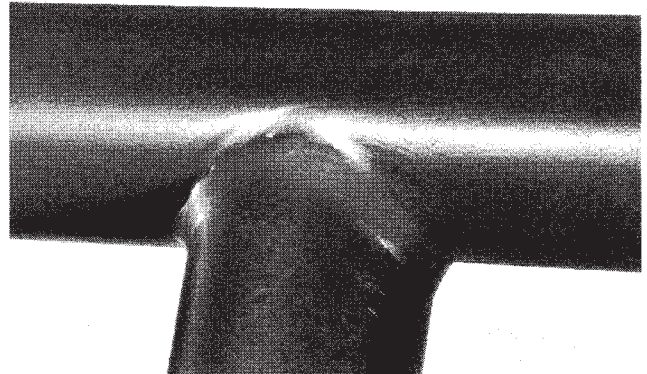

Type 2

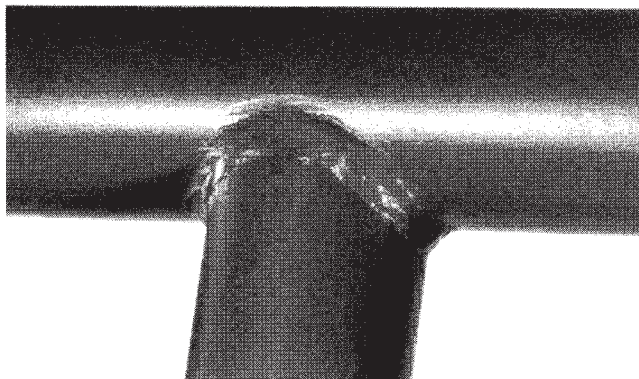

Type 3

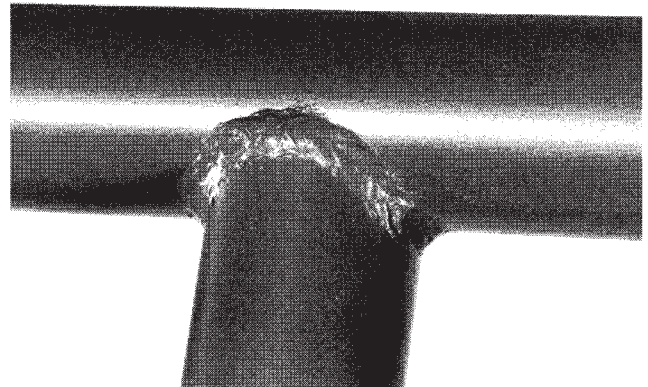

Type 4

The above descriptions for Railing System Joint Construction are based on “Voluntary Joint Finish Standards” developed by the National Ornamental & Miscellaneous Metals Association (NOMMA). Photographs were provided through the courtesy of NOMMA.

REPRESENTATIVE METHODS OF POST ANCHORAGE ON HORIZONTAL SURFACES

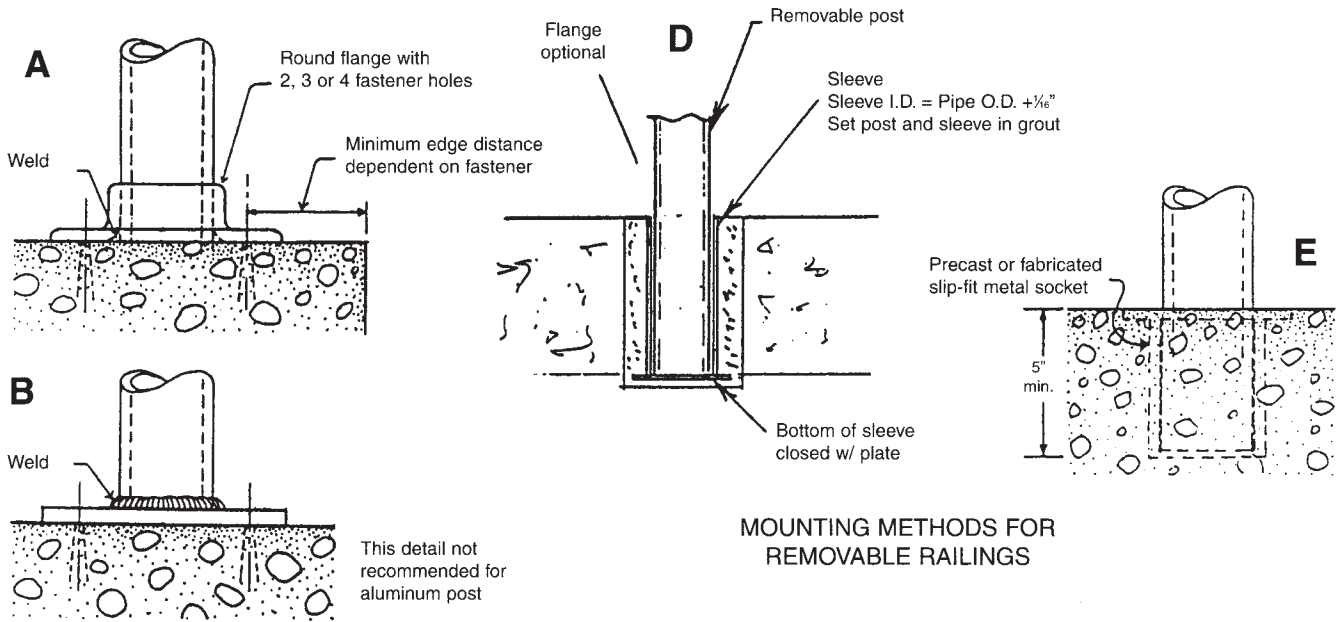

MOUNTING METHODS FOR REMOVABLE RAILINGS

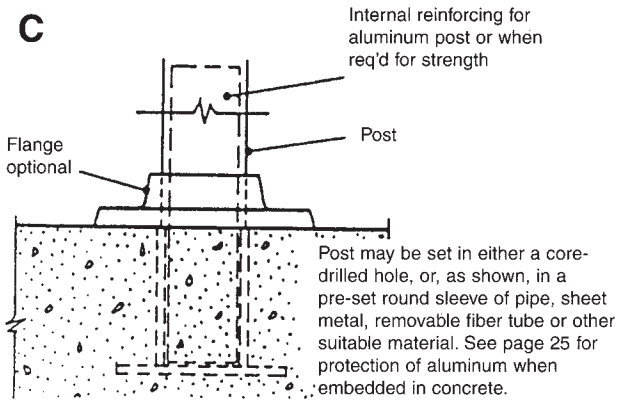

MOUNTING ON CONCRETE OR MASONRY

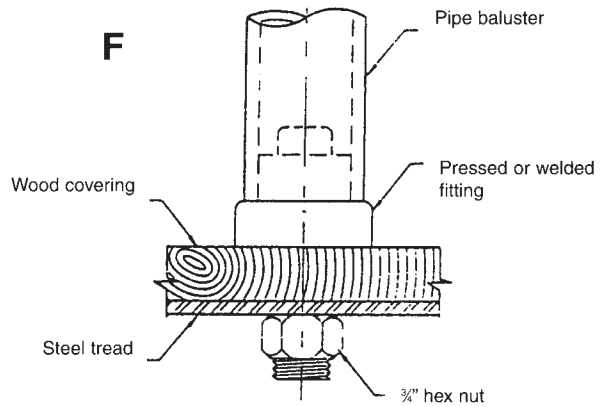

ANCHORAGE TO WOOD PLANK FLOOR OR STAIR TREAD

COMMON TYPES OF POST BASE

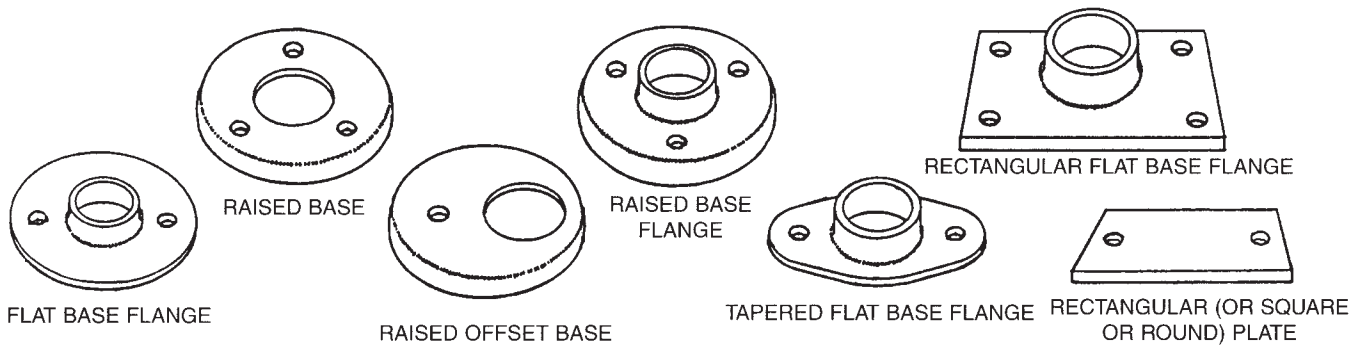

*Details shown in this section are those most commonly used. For the many others available, consult manufacturers' literature.

TYPICAL WELDED CONNECTIONS

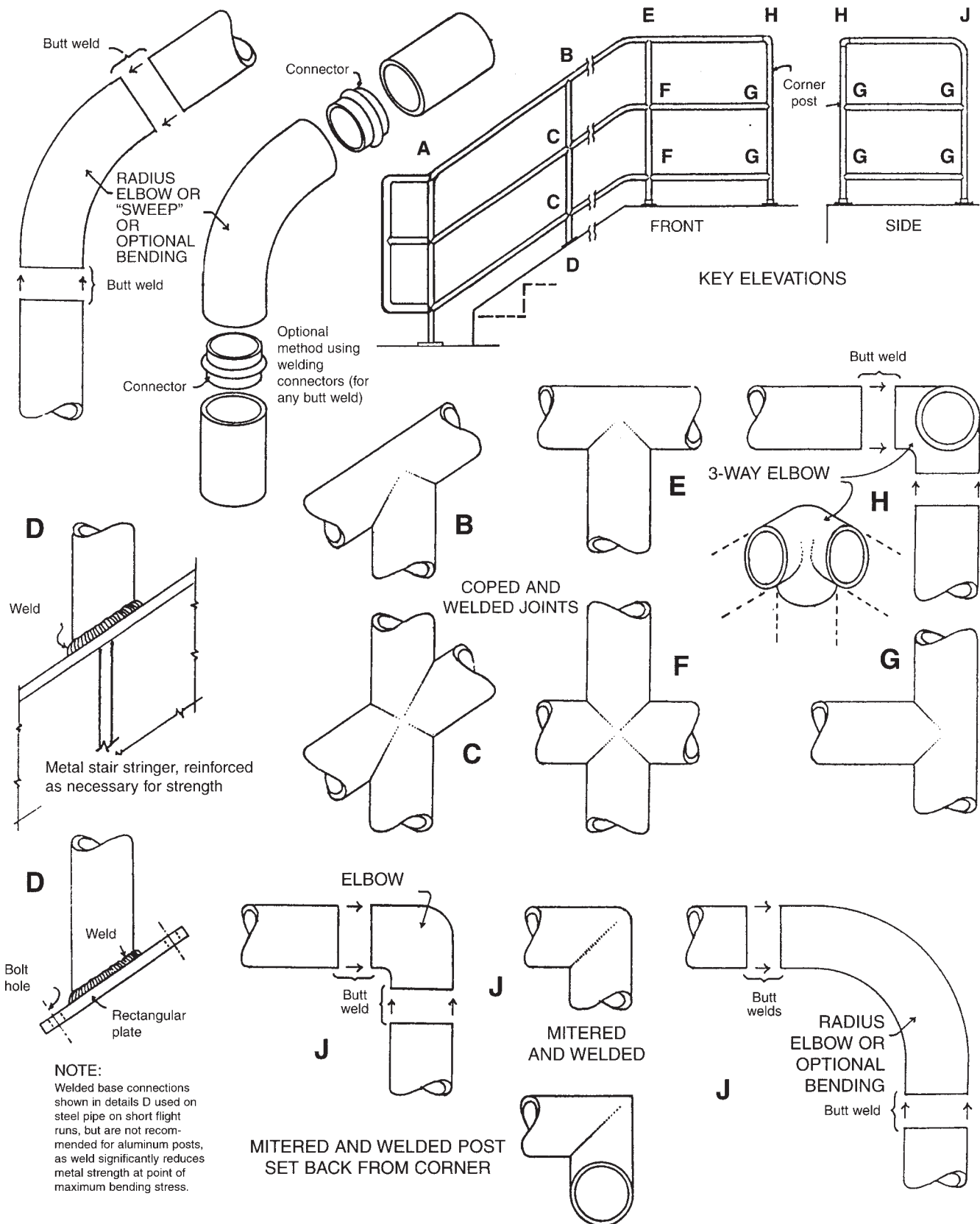

NOTE:
Welded base connections shown in details D used on steel pipe on short flight runs, but are not recommended for aluminum posts, as weld significantly reduces metal strength at point of maximum bending stress.

TYPICAL NON-WELDED CONNECTIONS

Sleeves mechanically fastened or adhesively bonded.

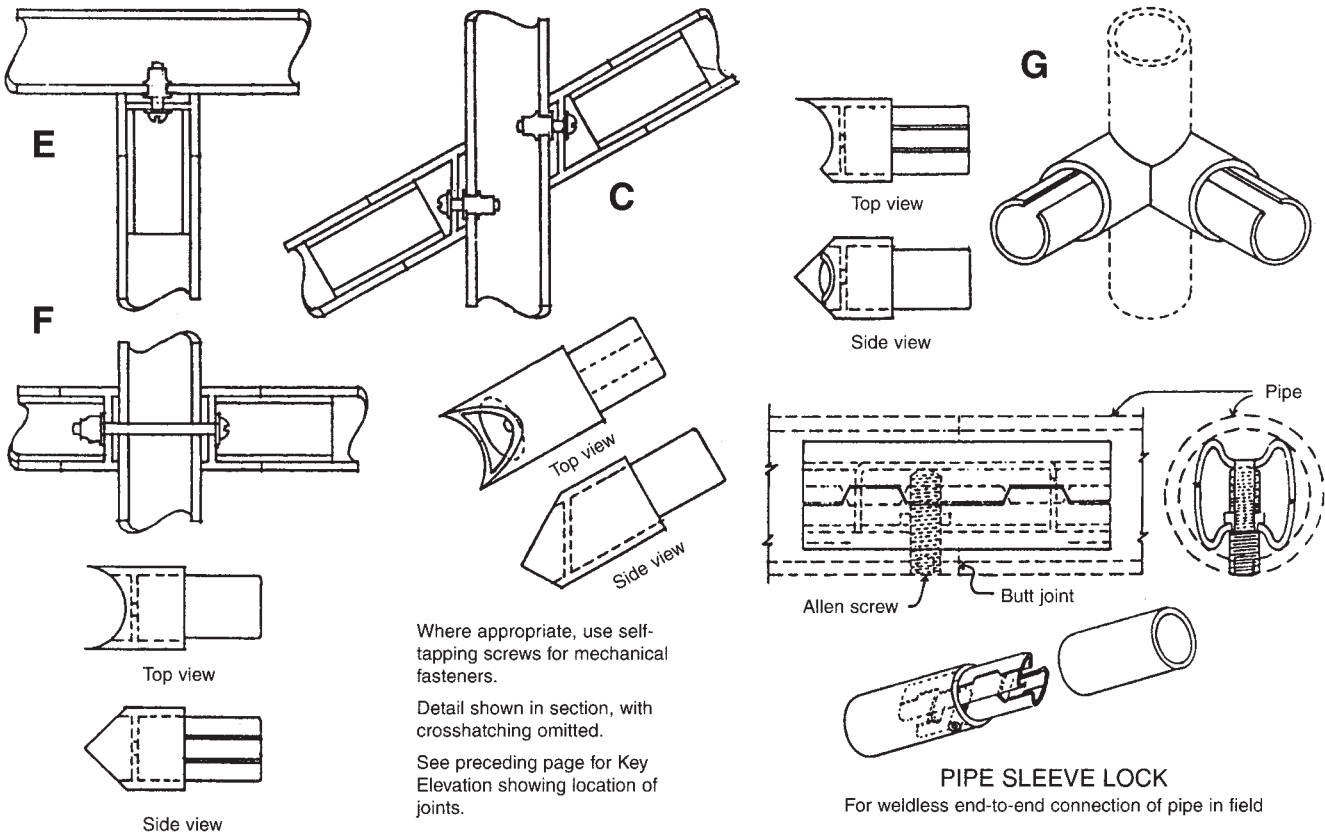

REPRESENTATIVE STAIR RAIL DETAILS

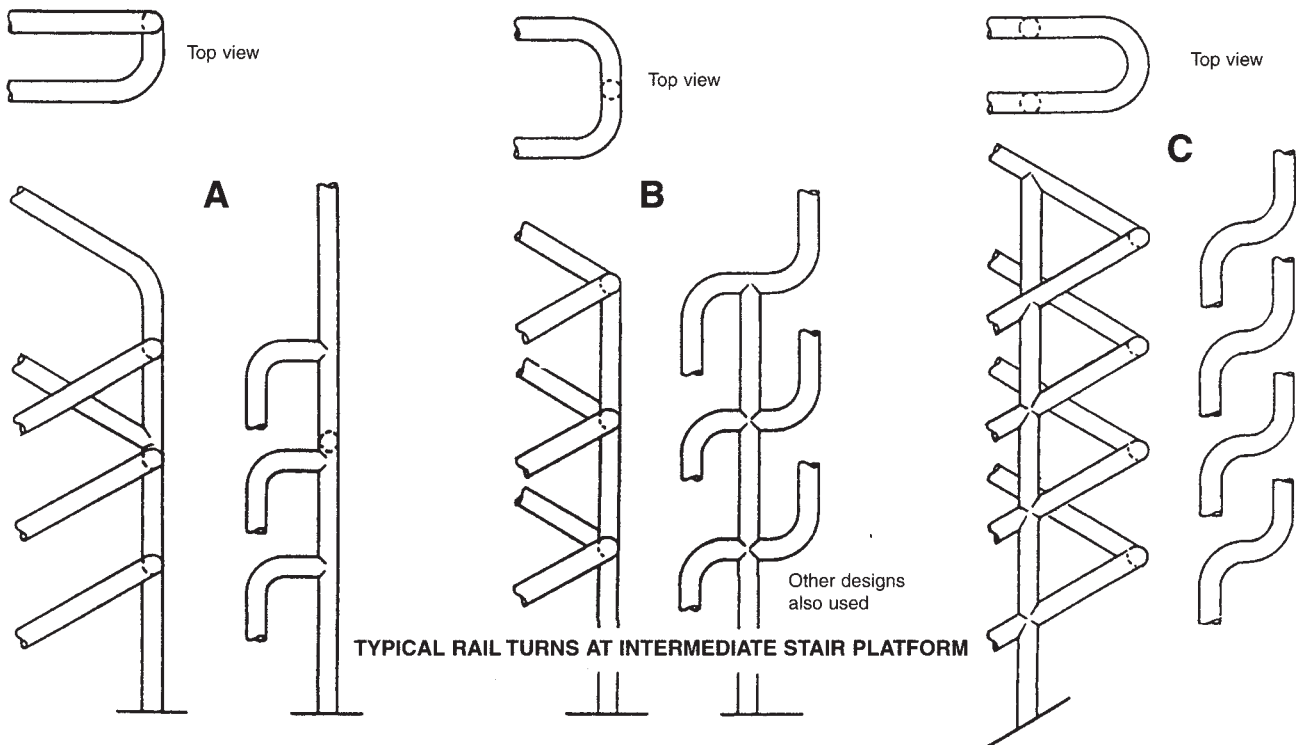

REPRESENTATIVE SIDE MOUNT METHODS FOR POSTS

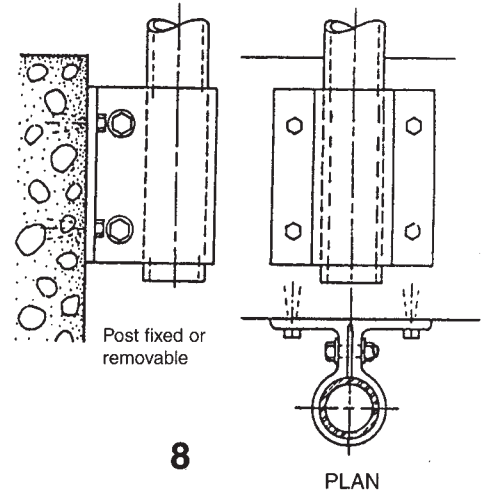
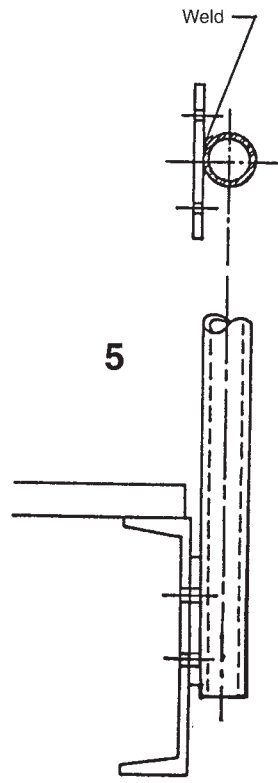
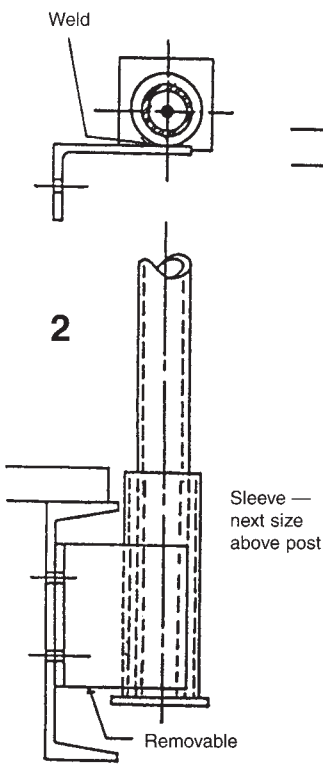
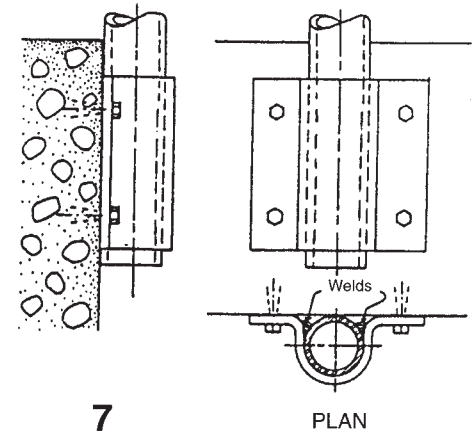
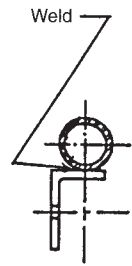
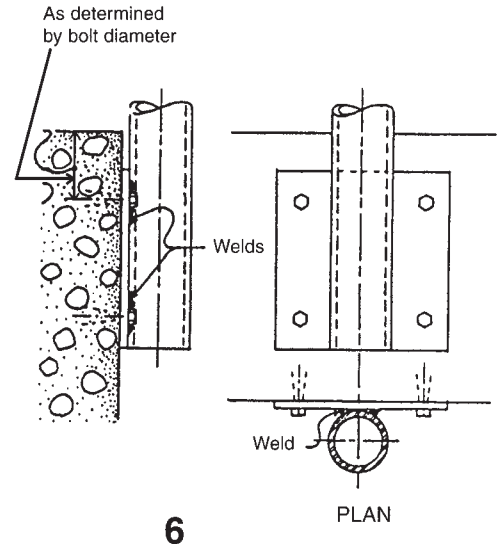
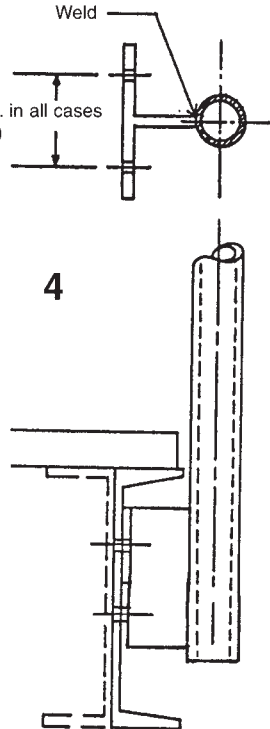
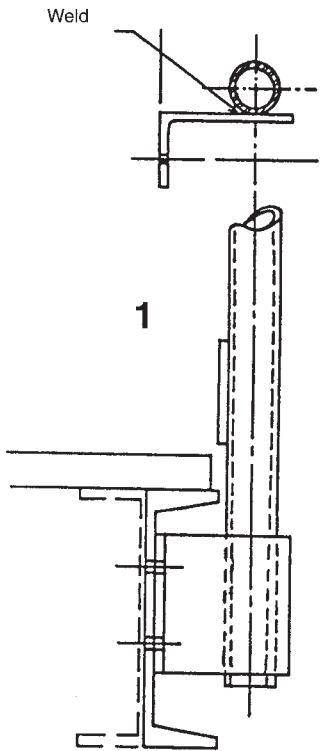

WALL RETURNS FOR HANDRAILS

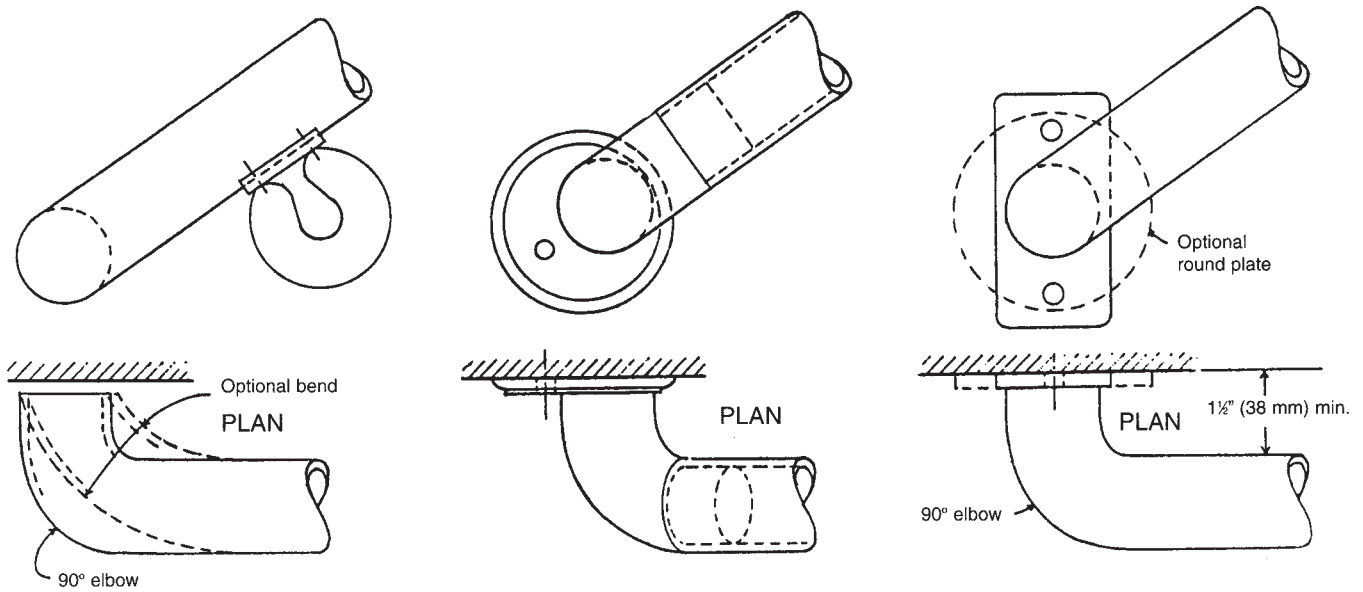

COMMON TYPES OF HANDRAIL BRACKET

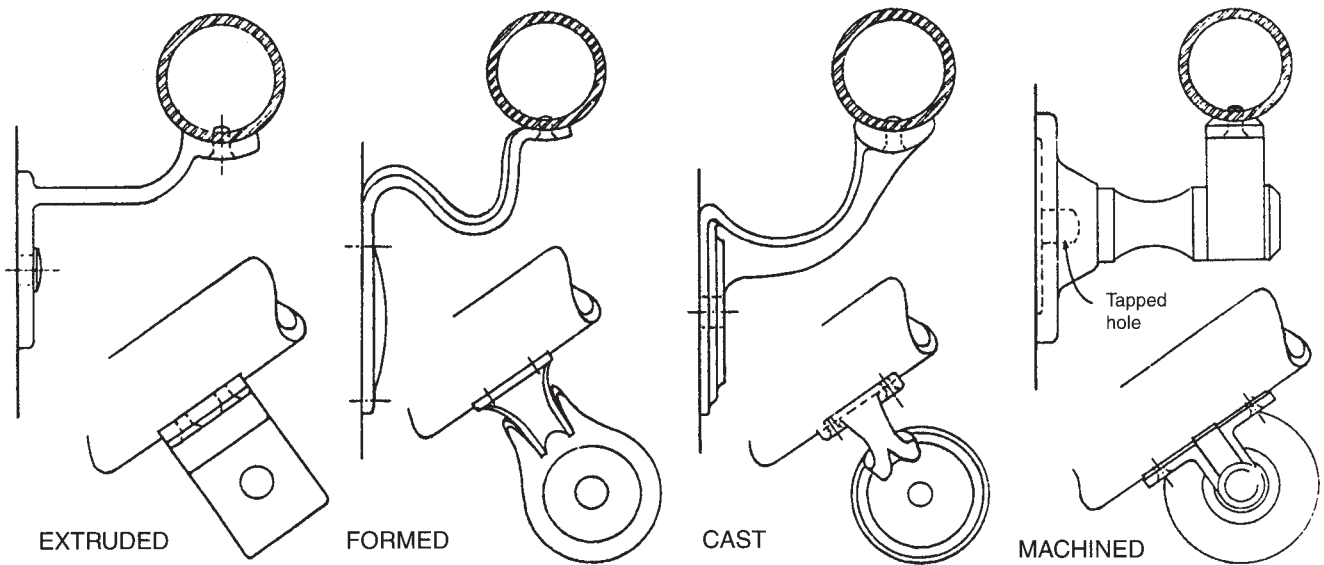

METHODS OF FASTENING HANDRAIL BRACKETS TO WALL

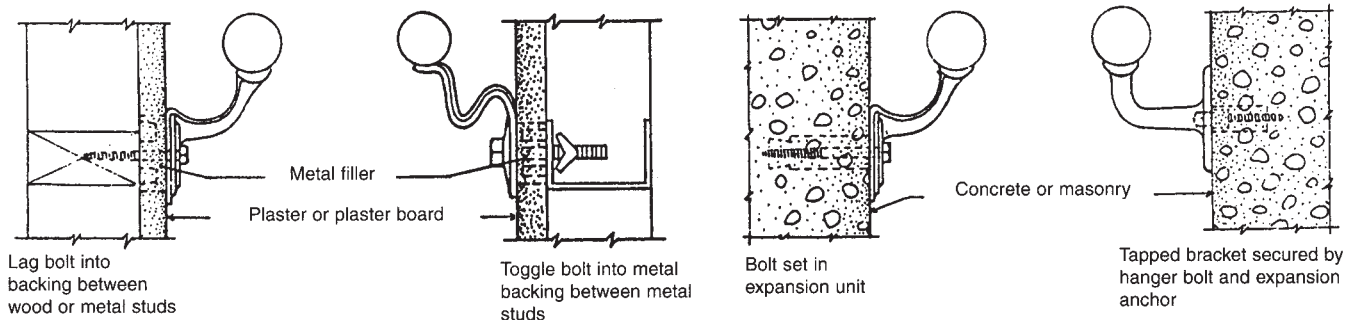

Note: See Guide Specifications 1.04.E

STRUCTURAL DESIGN

Traditionally, most railing systems have been designed in accordance with the requirements of state or local codes (where such requirements existed), or to the special requirements of specific installations. In some instances, railing systems have probably been constructed without a formal design review.

Now, with the increased concern for both public and employee safety, as reflected in current Federal regulations; with more and more codes specifying design loads for railing systems; and with increasing emphasis on designer's liability for product failure, structural design of railing systems has become a major consideration for architects and engineers.

In the structural design of any railing system, the following information is essential:

1. The design criteria, as prescribed by governing regulations or the designer's specifications;
2. The allowable design stresses of railing materials;
3. The structural values of fastenings and anchorage devices;
4. The properties of the sections to be used;
5. Formulas for structural design;
6. The properties of the supporting structures.

In some cases, information obtained by actual physical load testing is also needed.

Design Criteria

Design criteria for railing systems are set by the governing code for the area in which the railing systems are to be used. These criteria include both loading and dimensional requirements.

The three model codes previously published by BOCAI, ICBO, and SBCCI are being replaced by the International Building Code (IBC) published by the International Code Council (ICC).

While a model code has no legal standing, it is usually adopted in whole or in part by state and local government agencies so that its requirements become legally binding on designers and builders.

Other major organizations which publish standards relating to railing systems are:

American Society for Testing and Materials:

ASTM E 894 Test Method for Anchorage of Permanent Metal Railing Systems and Rails;
ASTM E 935 Test Methods for Performance of Permanent Metal Railing Systems and Rails
ASTM E 985 Specification for Permanent Metal Railing Systems and Rails for Buildings
ASTM E 1481 Terminology of Railing Systems and Rails for Buildings

American Society of Civil Engineers:

ASCE 7 Minimum Design Loads for Buildings and Other Structures

American National Standards Institute:

ANSI A 117.1 Guidelines for Accessible and Usable Buildings and Facilities
ANSI A 1264.1 Safety Requirements for Workplace Floor and Wall Openings, Stairs, and Railing Systems

National Fire Protection Association:

NFPA 101 Life Safety Code

As in the case of the three model codes the standards of the foregoing organizations are voluntary and have no legal standing unless referenced or written into the building codes of regulatory agencies.

The federal government has also established design requirements for railing systems through the Occupational Safety and Health Administration (OSHA) of the Department of Labor. The requirements appear in the Code of Federal Regulations, Title 29 - Labor; Parts 1900 to 1910.

With the passage of the Americans with Disabilities Act in 1990, the Architectural and Transportation Barriers Compliance Board (ATBCB) has been delegated the responsibility for seeing that building standards, where applicable, meet the intentions of this act. Where railing systems are concerned, the standards are those in ANSI A117.1 for the physically disabled.

The design loading specified for railing systems shall be uniform, concentrated, or both, but shall not be combined to act simultaneously. Certain control dimensions shall also be specified.

Uniform loading, specified by some building codes, represents the force exerted by tightly grouped persons leaning on or pressing against the railing system. Such loading requirements range from 20 to 50 pounds per foot (290 to 730 newtons per meter), applied horizontally to the top rail. In some codes, railing systems in certain locations shall be designed for loads as high as 100 pounds per foot (1460 newtons per meter) applied vertically downward on the rails and the vertical and horizontal uniform loads shall be applied simultaneously.

Concentrated loading represents the force exerted by a single individual leaning upon or over the rail or a person or object being hurled against the rail. This type of design loading is specified in the majority of codes although some codes only have uniform load requirements. A 200 pound (890 newton) concentrated load applied in any direction at any point along the top rail has become a requirement of a number of codes and government regulatory agencies. Current thinking by some organizations is to apply the concentrated load in a perpendicular direction at any point along the top rail, horizontally and downward in a vertical plane, but not simultaneously. Perpendicular horizontal loading applies the maximum moment to the post, and the downward loading simulates what a person leaning over the rail might apply.

A guardrail system is defined as a vertical protective barrier erected along exposed edges of stairways, balconies, etc. (See Glossary) Some codes now have a minimum requirement that guardrail systems shall withstand the same loads applied at the top that railing systems withstand. However, depending on the occupancy and use of a building or structure, guardrail systems shall withstand significantly higher loads. Another requirement for guardrail systems is that intermediate rails, balusters, and panel fillers shall be designed to withstand loads applied horizontally and perpendicular to the infill area. A uniform load of 25 psf (1200 Pa) over the gross area of the guardrail system, including the area of any openings, is a requirement of some codes. A 200 pound (890 newton) load applied on a one square foot (92 900 square millimeters) area at any location is a requirement appearing in other codes. However, reactions due to these loads shall not be added to the loads applied at the top of the guardrail system.

Other criteria, often specified by designers, pertain to performance under various specific types of impact or other loading conditions.

Building codes typically specify minimum and maximum heights for handrails and minimum spacings for intermediate rails. For new construction the majority of codes now require a minimum height of 34 in. (865 mm) and a maximum height of 38 in. (965 mm) for handrails measured vertically at nosing. The previous requirement was 30 in. (762 mm) minimum and 34 in. (865 mm) maximum. The 30 in. (762 mm) minimum is generally accepted for existing railing system installations. The minimum guardrail system height requirement of the majority of codes is 42 in. (1067 mm).

OSHA has a requirement that hand rails, posts, and top and intermediate rails shall be at least 1½ in. (38 mm) nominal diameter, with posts spaced not more than 8 feet (2.44 m) on centers. It has been clarified that the outside diameter shall be not less than 1½ in. (38 mm). Thus, a 1¼ in. (32 mm) (IPS) pipe, having an actual outside diameter of 1.66 in. (42 mm), meets this requirement.

For guardrail systems and stair-rail systems in areas accessible to the public, codes require spacing, between rails, balusters or other infill, small enough to prevent the passage of a sphere of diameter varying between 4 in. (102 mm) and 6 in. (153 mm). In areas of commercial and industrial occupancies, which are not accessible to the public, some codes permit this spacing to be increased to prevent passage of a 12 in. (305 mm) sphere and other codes permit an increase in spacing up to 24 in. (610 mm).

Provisions shall be made to accommodate physically handicapped persons where required. ANSI A117.1-98 describes the requirements for handrails for areas to be used by such persons. It specifies that the minimum clearance between handrail and wall shall be 1½ in. (38 mm). The actual minimum diameter of handrails shall be 1¼ in. (32 mm) and the actual maximum diameter shall be 2 in. (51 mm). The use of these actual outside dimensions has eliminated the confusion which sometimes arose when nominal pipe sizes were used in previous editions.

ADA Accessibility Guidelines following an earlier edition of ANSI 117.1 specified 1¼ in. (32 mm) to 1½ in. (38 mm) diameter limits for handrails, but like ANSI has now recognized and accepted the larger outside diameters of these nominal pipe sizes.

Governing codes shall be checked for their specific requirements; and government regulations, such as OSHA and ADA, shall be checked also. In certain instances, the requirements of the latter will be more rigorous than those of the governing jurisdiction.

Design Considerations

The most critical loads are those which are applied horizontally, as these produce the maximum bending moments on posts. The maximum bending moment on a rail occurs either under a concentrated load when the load is applied at mid-span or under a uniform load due to a long span between supports.

Posts act as columns in resisting vertical loading on rails and as vertical cantilever beams in resisting horizontal loading on either the rails or the posts. The bending moment due to the cantilever beam action under horizontal loading shall determine the size of the post.

The critical bending moment in the posts shall be determined by either 1) the application of a uniform load to the rail, or 2) the application of a concentrated load to the top of the post itself or to the rails it supports. Bending moment in the rail, whether the loading is uniform or concentrated, is a function of the post spacing.

The same size (OD) pipe (though not necessarily the same "schedule") shall be used for both posts and rails. Additional loading shall be sustained by adding reinforcement to the post or by spacing the posts closer together.

Distribution of Loads to Posts

Uniform loading shall be applied over the full length of the rail. The size of all posts shall be determined by the loading on an intermediate post; e.g., the load per foot (meter) multiplied by the post spacing, or span, in feet (meters), if the spans are of uniform length. End posts carry only half as much uniform rail load but the same concentrated load as the intermediate posts and shall be made of the same pipe size.

Concentrated loading is assumed to be applied at any point along the rail. The formula for concentrated post loading (page 19) applies to straight-run rails with uniform post spacing. For installations where the rail is laterally braced by a change in direction or attachment to other structure, bending moment in posts may be reduced significantly. Similarly in a railing system where balusters or posts are mounted securely into the floor or stair slab, the load applied to the rail at a post is distributed to other posts on either side of the post under stress, reducing the load applied to that post. This reduction is dependent on the stiffness of the rail relative to the stiffness of the post and a load propor-

tion factor which is found from the graph on page 17.

Stiffness ratio for distributing load:

$$CR = C_{\text{rail}} / C_{\text{post}} \quad C_{\text{post}} = EI / h \quad C_{\text{rail}} = EI / L$$

As the post spacing increases, the proportion of load distributed becomes less, and it is assumed that at maximum limits the post is designed to sustain the total design load. Since the variety of possible installation conditions is virtually limitless, only the straight-run condition, which provides conservative design values for all situations, is presented.

In railing systems where posts and rails are of identical material and section, and where post spacing usually varies between 3 feet (1m) and 6 feet (2m), load distribution is fairly uniform and the greatest proportion of a concentrated load carried by any one post can be estimated as follows:

End posts: of a 2-span rail - 85%
of a rail with 3 or more spans - 82%

Intermediate posts: of a 2-span rail - 65%
of a rail with 3 or more spans - 60%

Thus, if a 200 pound (890 newton) concentrated load is specified, actual design load to be applied at the top of end and intermediate post of a railing system of three or more spans is found to be 164 pounds (730 newtons) and 120 pounds (534 newtons) respectively.

Note: If end posts differ from intermediate posts in strength, the load distribution pattern changes.

In single span railing systems, each post shall be designed to carry the full concentrated load.

Design Stresses and Performance Testing

The design stresses for pipe and round tube, in standard engineering practice, are shown in Table 1. Although considered by some to be too conservative for railing system design, these are the stresses used in the following illustrative examples.

Some designers feel that, particularly in the case of high concentrated loads such as specified by OSHA, the use of higher bending stresses is justified, on the grounds that such loading must necessarily be of a momentary rather than sustained nature. The validity of this position depends largely upon what is considered acceptable railing system performance and how "failure" is defined.

The purpose of design regulations is to insure that railing systems provide protection against persons falling, and the railing system need not remain in perfect alignment to perform this function. If the regulatory agency will accept a slight permanent deformation in the unlikely event that the railing system is subjected to maximum design loading, this permits theoretically the use of a design bending stress approaching or equal to the yield stress.

It is recognized that the use of such higher design stresses is not generally accepted as representing standard engineering analysis except possibly in LRFD. However, actual physical testing has demonstrated repeatedly that securely anchored pipe railing systems are capable of carrying, with little or no permanent deformation, loads much greater than those computed on the basis of the conservative conventional allowable bending stresses. Some manufacturers feel, therefore, the proof of performance by physical testing is a more valid criterion for acceptability than the requirement that their design employ standard engineering analysis. Such testing, however, shall be performed by qualified personnel, and test loads shall allow for a reasonable factor of safety. The recommended test methods for evaluating the performance of metal railing systems and rails shall be those specified in ASTM E 935.

Design Procedure

The structural design of railing systems includes these steps:

- 1) with the rail height given and the post spacing either given or arbitrarily assumed, post size shall be determined in accordance with the specified loading;
- 2) assuming the rail member to be the same size as the post, this size shall be adequate to carry its own loading over the given (or assumed) span;
- 3) if the rail size is inadequate, either its maximum permissible span shall be computed and the post spacing shall be reduced accordingly, or the size of the rail (and posts) shall be increased.

The examples on the following pages illustrate this process.

RAILING SYSTEM LOAD DISTRIBUTION

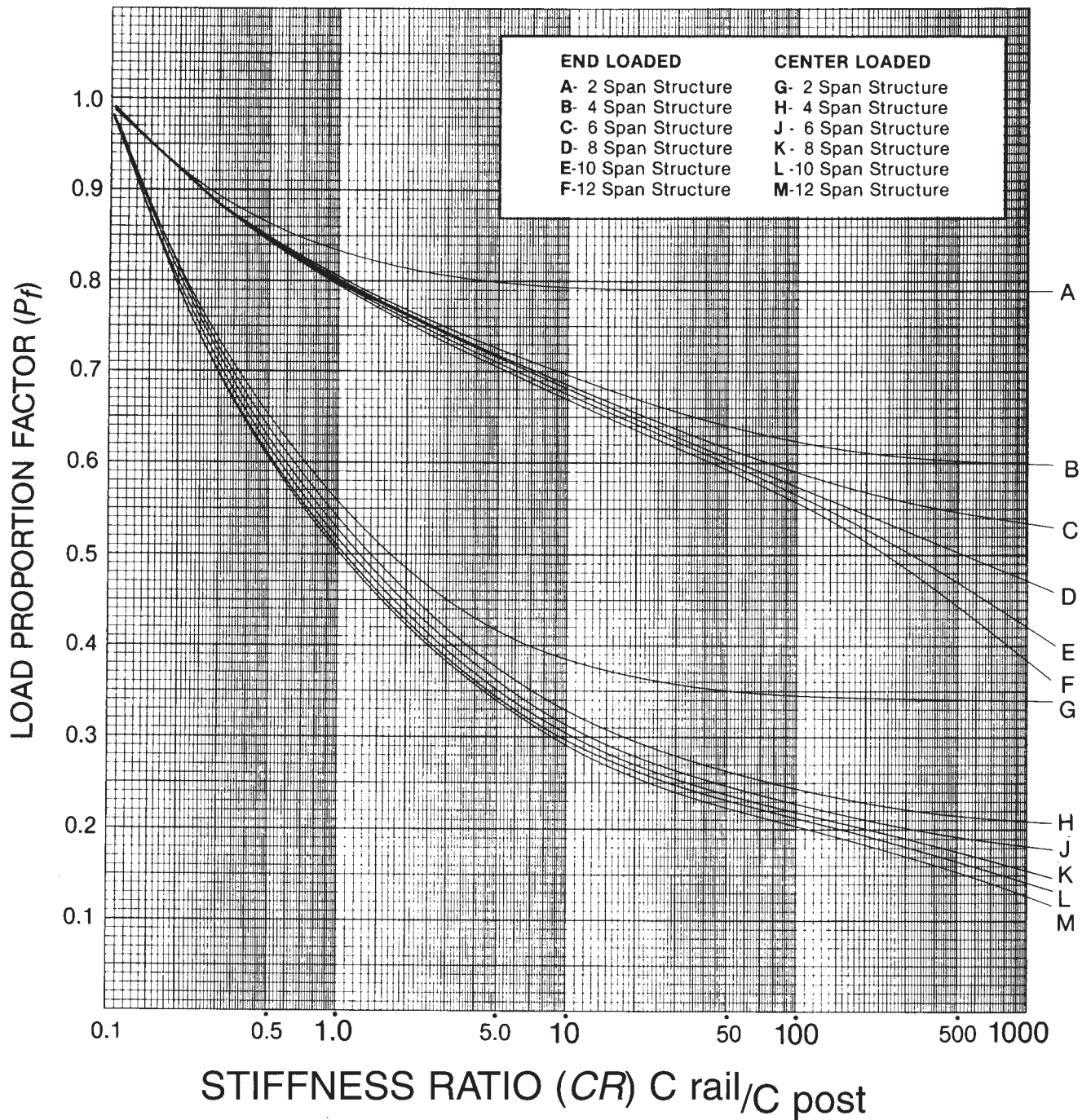

$$CR = \frac{C_{rail}}{C_{post}} \quad C_{post} = \frac{EI}{h} \quad C_{rail} = \frac{EI}{L}$$

The stiffness ratio (*CR*) is then plotted on the graph above to obtain Load Proportion Factor (*P_f*).

When the load proportion factor has been determined, it is multiplied by the total load to determine the load one post must sustain.

This graph has been determined by computer analysis and confirmed by laboratory test.

STRUCTURAL DESIGN

TABLE 1 TENSILE, YIELD AND DESIGN STRESSES — PIPE AND ROUND TUBING

| Metal and Grade or Alloy | Minimum Tensile Strength, F_t ksi (MPa) | Minimum Yield Strength, F_y ksi (MPa) | Design Stress⁽¹⁾ in Bending, F_b ksi (MPa) |
|--|---|---|---|
| Carbon Steel Pipe [ASTM A 53] | | | |
| Type F | 48 (330) | 30 (205) | 21.6 (150) |
| Type E and S, Grade A | 48 (330) | 30 (205) | 21.6 (150) |
| Grade B | 60 (415) | 35 (240) | 25.0 (170) |
| Carbon Steel Structural Tubing [ASTM A 500] | | | |
| Grade B | 58 (400) | 42 (290) | 30.0 (205) |
| Grade C | 62 (427) | 46 (317) | 33.0 (230) |
| [ASTM A 501] | 58 (400) | 36 (250) | 26.0 (175) |
| [ASTM A 513] Type 5 | 60 (414) | 50 (345) | 30.0 (205) |
| Aluminum Pipe and Tube | | | |
| 6063-T5, 6063-T52 [ASTM B 221] | 22 (150) | 16 (110) | 11.5 (80)* |
| 6063-T6 (Extruded) [ASTM B 221, B 429] | 30 (205) | 25 (170) | 18.0 (125)* |
| (Drawn) [ASTM B 210, B 483] | 33 (230) | 28 (195) | 20.0 (135)* |
| 6063-T832 [ASTM B 210, B 483] | 40 (275) | 35 (240) | 24.0 (165)* |
| 6061-T6 (Extruded) [ASTM B 221, B 429] | 38 (260) | 35 (240) | 24.0 (165)** |
| (Drawn) [ASTM B 210, B 483] | 42 (290) | 35 (240) | 24.0 (165)** |
| Stainless Steel Pipe [ASTM A 312] | | | |
| S30400, S31600 - Annealed | 75 (515) | 30 (205) | 18.0 (125) |
| Stainless Steel Tubing [ASTM A 554] | | | |
| S30400, S31600, Annealed | 75 (515) | 30 (205) | 18.0 (125) |
| S30400, S31600, Ornamental As-welded | 75 (515) | 50 (345)*** | 30.0 (205) |
| Architectural Bronze Extruded Shapes | | | |
| C38500 [ASTM B 455] | 48 (330) | 16 (110) | 10.0 (70) |
| Copper Pipe | | | |
| Alloy C23000, Temper H58 [ASTM B 43] | 40 (275) | 18 (125) | 11.0 (75) |

1) AISI 1985 "Criteria for Structural Applications of Steel Tubing and Pipe" specifies $F_b = 0.72F_y$. It also specifies that the diameter-thickness ratio of hollow circular sections shall not exceed $3300/F_y$. For aluminum, F_b values are those specified by the Aluminum Association; for stainless steel and copper, the F_b values shown are $0.60F_y$.

*reduce to 8 (55) within 1 in. (25 mm) of weld

**reduce to 14 (95) within 1 in. (25 mm) of weld

***required yield strength shall be specified when ordering

The following symbols (and equivalent metric units) are used in the design formulas:

- F_b design stress in bending, ksi (MPa)
- F_y yield stress, ksi (MPa)
- h height of rail from attachment to plane of loading, in. (mm)
- h_1 height of reinforcement, in. (mm)
- l rail span or post spacing, in. (mm)
- l_{max} maximum permissible value of l
- P concentrated load, lbf (N)
- S section modulus of member, in³ (mm³)
- w uniform load per foot, lbf/ft (N/m)

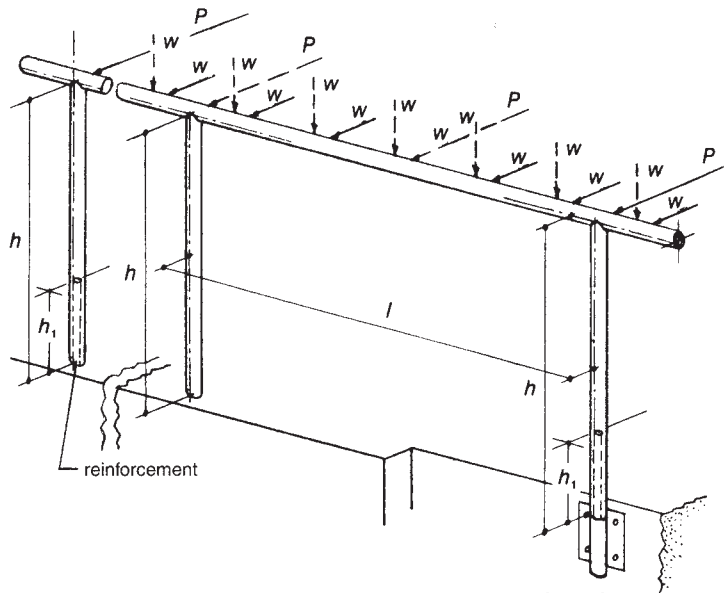

RAILING SYSTEM DIMENSIONS AND LOADS

The formulas used, and illustrative examples of their application, are given in the following.

1. To determine post size (loading, post spacing and rail height given)

The required section modulus is determined by the load acting horizontally at the top of the post. For

uniform loading, in U.S. standard units, $S = \frac{wlh}{12 \times 1000 F_b}$; in metric, $S = wlh / F_b$

For concentrated loading, in U.S. standard units, $S = \frac{Ph}{1000 F_b}$; in metric, $S = Ph / F_b$

A pipe size having an S value equal to or greater than the computed required value is then selected from Table 2.

Examples:

- a) Given: Loading on rail = 40 lb/ft.
Post spacing = 60 in.
Rail height (stairs) = 34 in.

Determine post size, using 6063 T6 aluminum pipe ($F_b = 18$ ksi)

$$S = \frac{wlh}{12 \times 1000 F_b} = \frac{40 \times 60 \times 34}{12 \times 1000 \times 18} = 0.378 \text{ in}^3$$

Select 1½"

Schedule 80 pipe; ($S = 0.412 \text{ in}^3$)

NOTE that if 6063 T832 or 6061 T6 aluminum, or A 500 steel tubing were substituted, either 1½" Schedule 40 or 1¼" Schedule 80 pipe would be adequate.

- b) Given: Loading on rail = 292 N/m
Post spacing = 1.5 m
Rail height = 1070 mm

Determine post size, using 6063 T6 aluminum pipe ($F_b = 125$ MPa)

$$S = wlh / F_b = 292 \times 1.5 \times 1070 / 125 = 3749 \text{ mm}^3$$

Use 1¼" Schedule 40 pipe ($S = 3896 \text{ mm}^3$)

- c) Given: 6-span railing system with OSHA concentrated loading of 200 lb
Post spacing — not significant with concentrated loading
Rail height = 42 in.

Determine post size, using A53 Grade B steel pipe ($F_b = 25$ ksi)

Due to load distribution, (see p. 15), the design load for an intermediate post is 60% of 200, or 120 lb; for an end post, 82% of 200, or 164 lb. Sizes of both types of post must be determined.

STRUCTURAL DESIGN

For intermediate posts, $S = \frac{Ph}{1000 F_b} = \frac{120 \times 42}{1000 \times 25} = 0.202 \text{ in}^3$

Use 1 1/4" Std Pipe

1.66" OD x .140" wall ($S = 0.235 \text{ in}^3$)

For end posts, $S = \frac{164 \times 42}{1000 \times 25} = 0.276 \text{ in}^3$

As the pipe selected for the intermediate posts does not have this S value, a stronger member, with a higher stiffness ratio, is required, and the 18% reduction of load, which is based on the post having equal stiffness, no longer applies. To be on the safe side, the end post should be designed to carry the full 200 lb load, in which case

Required $S = \frac{200 \times 42}{1000 \times 25} = 0.336 \text{ in}^3$

Use the 1 1/4" Std Pipe with a close fitting internal reinforcing bar in the lower 18 inches of the post. This bar will extend at least 12 inches above the floor, reducing the effective height to 30 inches at which point the

required S is $0.336 \times \frac{30}{42}$, or 0.240 in^3

For intermediate post $S = 0.235 \text{ in}^3$

To find height, h_1 , of reinforcement for end post assuming the full 200 pound concentrated load is applied and it is desired to use the same pipe as that used for the intermediate posts

$$h_1 = h - \frac{1000 F_b S}{P} = 42 - \frac{1000 \times 25 \times 0.235}{200}$$

$h_1 = 42 - 29.4 = 12.6 \text{ in. say } 13 \text{ in.}$

Check S at floor level to see that it meets or exceeds the required 0.336 in^3

With a close fitting reinforcement the post can be considered a solid round bar at the floor. OD = 1.66"

$$S = \frac{\pi d^3}{32} = \frac{\pi (1.66)^3}{32} = 0.449 \text{ in}^3$$

This is well within the requirement.

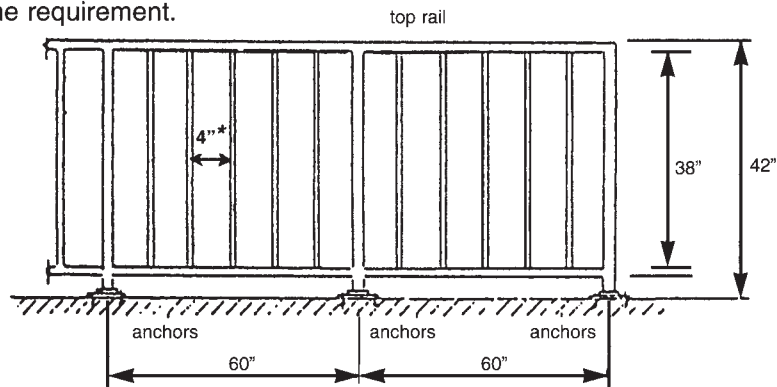

GUARDRAIL SYSTEM

- d) Given: Guardrail system has balusters at 4 1/2" (114mm) o.c. to provide clear space of 4" (102mm), or less, depending on baluster size ***Note: The clear space requirement varies depending on the applicable standard or code.** Baluster length, L , is 38" (965 mm). Concentrated load = 50 lb (220 N) on 1'-0" (305 mm) square.

Determine baluster size, using A36 steel rods.

Bending moment due to 50 lb (220 N) acting over 12" x 12" (305 mm x 305 mm) area:

Since balusters are on 4 1/2" (114 mm) centers, one baluster resists 18.75 lb (83 N)

$$M = P \times (2 \times L - a) / 8$$

$$M = 18.75 \times (2 \times 38 - 12) / 8 = 150 \text{ lb-in}$$

$$[M = 83 \times (2 \times 965 - 305) / 8 = 16.9 \text{ Nm}]$$

$$S = M / F_b$$

$$S = 150 / 18,000 = 0.00833 \text{ in}^3$$

$$[S = 16.9 \times 1000 / 125 = 135.2 \text{ mm}^3]$$

$$S = \pi d^3 / 32$$

$$d = (32 \times 0.00833 / \pi)^{1/3} = 0.44 \text{ in. } [d = 11.2 \text{ mm}] \text{ Use } \frac{1}{2}'' \text{ (12 mm) } \varnothing$$

Handrail is designed for the greater moment resulting from either 50 plf (730 N/m) or 200 lb (890 N):

$$M = wL^2 / 8$$

$$M = 50 \times 60 / 12 \times 60 / 8 = 1,875 \text{ lb-in}$$

$$[M = 730 \times 1.525 \times 1.525 / 8 = 212 \text{ Nm}]$$

or $M = PL/4$

$$M = 200 \times 60/4 = 3,000 \text{ lb-in}$$

$$[M = 890 \times 1.525/4 = 339 \text{ Nm}]$$

$$S = M/F_b$$

$$S = 3,000 / 25,000 = 0.12 \text{ in}^3$$

$$[S = 339 \times 1000 / 170 = 1\,994 \text{ mm}^3]$$

Use same size for bottom rail.

Post is designed for horizontal force of wL or P , whichever is greater:

$$50 \text{ plf} \times 5' = 250 \text{ lb.}$$

$$[730 \text{ N/m} \times 1.525 \text{ m} = 1\,113 \text{ N}]$$

$$M = 250 \times 42 = 10,500 \text{ lb-in } [M = 1\,113 \text{ N} \times 1\,065 \text{ mm} = 1\,185 \text{ Nm}]$$

$$S = 10,500 / 33,000 = 0.318 \text{ in}^3 [S = 1\,185 \times 1000 / 230 = 5\,152 \text{ mm}^3]$$

Use 1.900 OD x 0.145 A500 Gr C tubing ($S = 0.326 \text{ in}^3 = 5\,342 \text{ mm}^3$)

Use post size for top and bottom rails also.

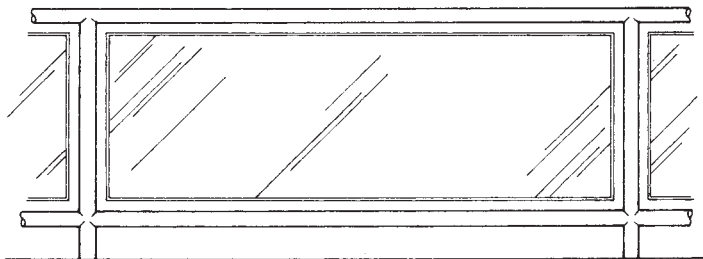

GUARDRAIL SYSTEM WITH PANEL

Panels of different materials are used with railing systems as shown in the drawing above. Such panels have to meet a uniform load requirement similar to that specified in Example 1.d. When this is the case the panel and the connectors to the rails and posts shall be adequate to withstand the load and transmit it. The use of a bottom rail depends on the structural properties of the panel.

2. **To determine rail size** (loading and post spacing given)

The S value computed in accord with the conditions of span and loading determines the rail size. If this is a smaller size than that required for the posts, the post size shall be used. If it is larger than that required for the post, either the post size shall be increased to match or, in the case of uniform rail loading, the rail span (post spacing) shall be reduced to the maximum allowable for the rail size.

For a concentrated load at mid-span of rail:

$$\text{single span rail: in U.S. standard units, } S = \frac{Pl}{4 \times 1000 F_b} ; \text{ in metric, } S = Pl / 4 F_b$$

$$\text{two or more spans: in U.S. standard units, } S = \frac{Pl}{5 \times 1000 F_b} ; \text{ in metric, } S = Pl / 5 F_b$$

For uniform loading on rail:

$$\text{1- or 2-span condition: in U.S. units, } S = \frac{wl^2}{96 \times 1000 F_b} ; \text{ in metric, } S = wl^2 / 8 F_b$$

$$\text{3 or more spans: in U.S. units, average } S = \frac{wl^2}{114 \times 1000 F_b} ; \text{ in metric, } S = wl^2 / 9.5 F_b$$

STRUCTURAL DESIGN

Examples:

- a) Given: Rail is annealed stainless steel tubing ($F_b = 18$ ksi)
Loading = 200 lb concentrated at mid-span
Post spacing = 72 in, multi-span condition

$$\text{Required section modulus, } S = \frac{Pl}{5 \times 1000 F_b} = \frac{200 \times 72}{5 \times 18,000} = 0.16 \text{ in}^3$$

Use 1.900" OD x 0.065 wall tubing. $S = 0.235 \text{ in}^3$. Check post size.

- a) Given: Rail is A500 Gr B steel tubing ($F_b = 30$ ksi)
Loading = 50 lb/ft
Post spacing = 60 in. more than 3 spans.

$$\text{Required section modulus, } S = \frac{wl^2}{114 \times 1000 F_b} = \frac{50 \times 60^2}{114 \times 30,000} = 0.053 \text{ in}^3$$

Use ANSI minimum rail size, 1.315" OD x 0.133" ($S = 0.133$) wall tubing, provided that this size is adequate for posts. **Check post size.**

3. To determine maximum post spacing (rail size and loading given)

When the rail is designed to carry uniform loading, the rail load is proportional to the rail span, and post spacing is limited by either the post strength or the rail strength. When the critical design load is a concentrated load, it is the strength of the rail member that limits the post spacing.

— as limited by post strength: in U.S. units, $l_{max} = \frac{12 \times 1000 F_b S}{wh}$; in metric, $l_{max} = F_b S / wh$

— as limited by rail strength

1- or 2-span condition: in U.S. units, $l_{max} = \sqrt{\frac{96 \times 1000 F_b S}{w}}$; in metric, $l_{max} = \sqrt{8 F_b S / w}$

3 or more spans: in U.S. units, $l_{max} = \sqrt{\frac{114 \times 1000 F_b S}{w}}$; in metric, $l_{max} = \sqrt{9.5 F_b S / w}$

To determine maximum spacing when a concentrated load is applied to the rail at mid span:

single span rail: in U.S. units, $l_{max} = \frac{4 \times 1000 F_b S}{P}$; in metric, $l_{max} = 4 F_b S / P$

2 or more spans: in U.S. units, $l_{max} = \frac{5 \times 1000 F_b S}{P}$; in metric, $l_{max} = 5 F_b S / P$

If the computed maximum spacing exceeds 8 feet (2.44m), reduce spacing to 8 feet (2.44m) to conform with OSHA regulations. If the computed maximum spacing is less than the assumed spacing, either decrease that spacing or increase the pipe size (for both posts and rails), and recheck the design.

Examples:

- a) Given: Posts and rails are 6063 T832 aluminum tube, 44 mm by 3 mm
($F_b = 165$ MPa)
Railing height (stairs) = 865 mm
Loading = 365 N/m

Determine maximum post spacing as limited by post strength.

From Table 3M, the S value for this tube is found to be 3970 mm³.

$$\text{Then } l_{max} = F_b S / wh = 165 \times 3970 / 365 \times 865 = 2.075 \text{ m} = 2 \text{ 075 mm}$$

- b) Given: Rail is 1¼" Schedule 40 6063 T6 aluminum pipe ($F_b = 18$ ksi)
Load = 25 lbf/ft
Two-span condition

Determine maximum post spacing as limited by rail strength

$$l_{max} = \sqrt{\frac{96000 S F_b}{w}} = \sqrt{\frac{96000 \times 0.235 \times 18}{25}}$$

$$= \sqrt{16243} = 127.2 \text{ in. — use 8 feet}$$

However, unless the rail height is low, the loading on the 8 ft. span will exceed the capacity of this pipe used as a post, and again the post spacing will be governed by post strength rather than rail strength.

- c) Given: Post and rails are A53 Grade B steel pipe 1.66" OD x .140" wall
 ($F_b = 25$ ksi)
 Multi-span condition
 Loading = 200 pounds concentrated at mid-span of rail.

Determine maximum post spacing as limited by rail strength.

$$l_{max} = \frac{5000 F_b S}{P} = \frac{5000 \times 25 \times 0.235}{200} = 146.9 \text{ in.}$$

Obviously such a large spacing is impractical, and shall be reduced to the maximum of 8 ft permitted under OSHA regulations.

The maximum spacing is limited by the post strength for a given rail height.

INSTALLATION AND ANCHORAGE

The performance and safety of pipe railing systems are determined principally by three factors: structural design, fabrication and installation. Each of these factors is of critical importance; a deficiency in any one of them can cause failure. Unless the railing system is properly installed, using mounting devices and fasteners, and the structure supporting it is sound and stable, proper design and good fabrication are no insurance against failure. It is essential, therefore, that careful attention be paid to the details of installation and anchorage.

Post Attachment

The point of greatest stress, and therefore the most critical point in any railing system, is at the base of the post, where it is attached to the supporting structure. Whatever the supporting structure — metal, masonry or wood — attachment procedures are much the same; only the type of fastener will vary. A post or baluster is mounted on the fascia or stringer of a platform or stair, set into the floor or stair tread surface, or mounted on the floor or tread surface, as shown in the Construction Details section of this Manual.

Mounting on a fascia or stringer face has several advantages. The railing system does not reduce the width of the stair or platform. Available stock fittings or shop welding make installation easy without need for field welding. Fittings distribute the stress transmitted by the post, and, if required, include a reinforcing bar to strengthen the lower part of the post. Fascia are fastened to the structure by means of anchors, machine bolts or lag screws, depending on the structural material.

When posts are set into concrete or masonry floors or treads, sleeves of pipe, sheet metal, removable fiber, cardboard or foam polystyrene, provided by the railing system fabricator, are used during construction to form holes for receiving the posts. The sleeves shall be large enough to allow for field variation in their spacing or alignment and still leave sufficient space for grouting. They shall be of sufficient depth to provide ample post support and shall be kept covered until the railing system is installed, to prevent accumulation of debris or collection of water subject to freezing. A coat of bituminous paint, methacrylate lacquer, zinc chromate primer or other suitable coating shall be applied to the ends of aluminum posts to protect against accelerated corrosion caused by contact with concrete, grout or dissimilar metals.

Where water can enter posts, in outdoor installations, weep holes shall be provided at their lower ends to provide drainage and prevent possible damage by freezing. If required, expansion joints shall be provided in continuous rail runs.

When a railing system is to be set on an existing floor, post holes shall be drilled with a core drill. The edge of the hole shall be at least 3-1/2 inches (90mm) from the edge of the concrete or masonry. Assuming minimum concrete strength, check to see if reinforcing is required between edge and hole, and the depth to which post shall be set to achieve full post strength. Where required, a post shall be strengthened by internal reinforcement.

When a railing system is mounted on the floor surface or stair tread, the mounting shall be designed to withstand the required loading and to support and reinforce the post. Bracing is provided by a change in direction of the rail, as, for example, on a curved stair or at a landing. If the designer calls for the railing system to be mounted on top of the narrow flange of a light (MC) stringer channel, the stringer shall be investigated to determine if stiffeners are required. A railing system attached to an open riser stair having thin concrete or terrazzo treads and no face stringer poses a special attachment problem. One solution is to run the post through one tread and fasten it to the back edge of the tread below, to obtain two-point support. If that method is not feasible, an internal reinforcing bar is threaded and attached with a nut and large washer both above and below the tread. The post is then slipped over the bar and fastened with a set screw. In this case the entire load at the base of the post is transferred to the reinforcing bar. The number of posts and their spacing shall be determined by their lateral load bearing capacity.

A common attachment problem occurs when the stringer of a steel stair is so light that it twists when subjected to the lateral thrust of a post under load. In such cases, either the post shall be located at riser ends or a brace shall be welded to the under side of the tread and to the inside face of the stringer, as shown in Figure 1. A special bracket with a brace attached to the under side of the tread shall be used, if required, when a post is attached to the side of a thin tread where no stringer is used.

Wall Handrails

Wall-mounted handrails shall be designed to withstand the loads required by OSHA standards and building codes. Mounting is rarely a problem when the handrails are attached to concrete, masonry, hollow tile or wood. Suitable mounting brackets of steel, malleable iron, aluminum and stainless steel are available to meet load requirements. However, problems arise when a handrail is attached to a drywall partition with no solid material for anchoring. Proper architectural design shall provide suitable support built into such hollow partitions.

INSTALLATION AND ANCHORAGE

Fastener Selection

Required fastener capacity is determined by computing the moment about a fastener or support and solving for required pullout strength, using the equation $F = Ph/d$. The use of this equation, which is basically the same for all mounting arrangements, is illustrated in Figure 2.

Various fastener manufacturers provide wedge-type anchor bolts that require drilling a hole no larger than the size of the anchor in concrete. This type of anchor permits using the mounting flange as a template for accurately locating the holes.

Because of the uneven quality of concrete, a safety factor of four (4) shall be applied to the pullout requirement when selecting a bolt from the manufacturer's table of fastener pullout strengths. Thus, if the expected total pullout force is 2,000 pounds (8 900 newtons), and if the load is equally distributed between two anchors, each anchor shall be designed to hold 4,000 pounds (17 800 newtons).

Minimum anchor embedment shall be determined from manufacturers' design data. Anchor holes shall be drilled no closer than five (5) hole diameters from the edge of the concrete or masonry. If a 3/8 in. (9.5 mm) wedge type anchor sustains the required load, the holes shall be at least 2 in. (51 mm) from the edge.

Tap bolt directly into supporting member unless stringer or fascia is too light to provide a sufficient number of threads; in which case, a nut is applied to the far side of the support or a reinforcement plate is provided before drilling and tapping.

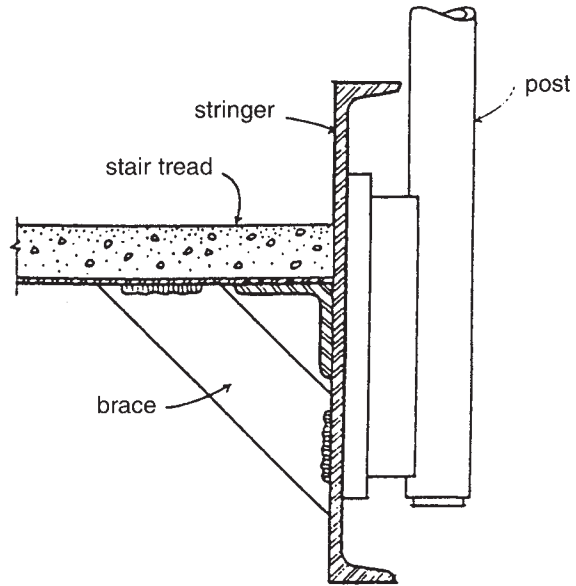

Figure 1. Use of a welded brace to prevent stringer twist.

As stated at the outset, the strength of the mounting and support of a railing system is just as important as the strength of the railing system itself. In the few cases where railing systems have failed, weak anchorage has nearly always been the cause. The manufacturers of railing system components and fastening devices have made available the parts and engineering information needed to provide proper anchorage, and qualified metal fabricators are ready to supply properly constructed railing systems. All of these are essential to good railing system design.

- P = Force (design load) applied to top rail, lb. (N)
- h = height of rail, in. (mm)
- d = anchor spacing, in. (mm)
- F = Force applied to fastener group in line, lb. (N)
- F_b = Force on one anchor, lb. (N)
- n = Number of fasteners in line

Apply safety factor (1.65 is typical) to calculated force on anchor to avoid overstressing, and safety factor (4 is typical) to pullout requirement of fastener in concrete to allow for poor quality of concrete.

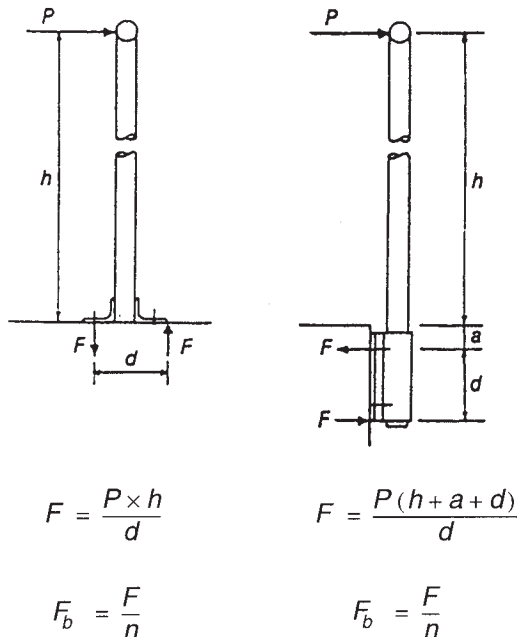

Figure 2. Equations for determining anchor bolt strength requirements

TABLE 2

PIPE DIMENSIONS AND PROPERTIES

| Nominal Size | Schedule No. | Outside Diam. | Diameter Inside in. | Thickness Wall in. | Area in. ² | Section Modulus, S in. ³ | Moment of Inertia, I in. ⁴ |
|--------------|--------------|---------------|------------------------|-----------------------|--------------------------|--|--|
| ¾ in. | 40 | 1.050 in. | 0.824 | 0.113 | 0.333 | 0.071 | 0.037 |
| | 80 | | 0.742 | 0.154 | 0.433 | 0.085 | 0.045 |
| 1 in. | 40 | 1.315 in. | 1.049 | 0.133 | 0.494 | 0.133 | 0.087 |
| | 80 | | 0.957 | 0.179 | 0.639 | 0.161 | 0.106 |
| 1¼ in. | 5 | 1.660 in. | 1.530 | 0.065 | 0.326 | 0.125 | 0.104 |
| | 10 | | 1.442 | 0.109 | 0.531 | 0.193 | 0.161 |
| | 40 | | 1.380 | 0.140 | 0.668 | 0.235 | 0.195 |
| | 80 | | 1.278 | 0.191 | 0.882 | 0.291 | 0.242 |
| 1½ in. | 5 | 1.900 in. | 1.770 | 0.065 | .0375 | 0.166 | 0.158 |
| | 10 | | 1.682 | 0.109 | 0.613 | 0.260 | 0.247 |
| | 40 | | 1.610 | 0.145 | 0.799 | 0.326 | 0.310 |
| | 80 | | 1.500 | 0.200 | 1.068 | 0.412 | 0.391 |
| 2 in. | 5 | 2.375 in. | 2.245 | 0.065 | 0.472 | 0.265 | 0.315 |
| | 10 | | 2.157 | 0.109 | 0.776 | 0.420 | 0.499 |
| | 40 | | 2.067 | 0.154 | 1.074 | 0.561 | 0.666 |
| | 80 | | 1.939 | 0.218 | 1.477 | 0.731 | 0.868 |

Pipe Dimensions: Pipe is produced in a variety of sizes or “schedules”, of which those more commonly used for railing systems are listed above. Schedule members conform to ANSI Standard B36.10, Welded and Seamless Wrought Steel Pipe.

In steel pipe, Schedule 40 is known as “Standard Weight” and Schedule 80 as “Extra Strong.” Standard weight is measured by I.P.S. (Iron Pipe Size), a designation of the nominal size. Unless otherwise specified, Schedule 40 is normally supplied in steel, aluminum or copper pipe and Schedule 5 in stainless steel tubing.

Round Tubing is also available in all four metals. It differs from pipe in that it is measured by a different system, designating the actual outside diameter and the wall thickness. Size designations may differ somewhat with the different metals.

TABLE 3

TUBE DIMENSIONS AND PROPERTIES

| Outside Diameter in. | Wall Thickness in. | Inside Diam. in. | Area in. ² | Section Modulus, S in. ³ | Moment of Inertia, I in. ⁴ |
|-------------------------|-----------------------|---------------------|--------------------------|--|--|
| 1 | 0.0625 | 0.875 | 0.184 | 0.041 | 0.020 |
| | 0.125 | 0.75 | 0.344 | 0.067 | 0.034 |
| 1.25 | 0.0625 | 1.125 | 0.233 | 0.066 | 0.041 |
| | 0.125 | 1 | 0.442 | 0.113 | 0.071 |
| 1.5 | 0.0625 | 1.375 | 0.282 | 0.097 | 0.073 |
| | 0.125 | 1.25 | 0.540 | 0.172 | 0.129 |
| | 0.1875 | 1.125 | 0.773 | 0.227 | 0.170 |
| | 0.25 | 1 | 0.982 | 0.266 | 0.199 |
| 2 | 0.0625 | 1.875 | 0.380 | 0.179 | 0.179 |
| | 0.125 | 1.75 | 0.736 | 0.325 | 0.325 |
| | 0.1875 | 1.625 | 1.068 | 0.443 | 0.443 |
| | 0.25 | 1.5 | 1.374 | 0.537 | 0.537 |
| 2.5 | 0.0625 | 2.375 | 0.479 | 0.285 | 0.356 |
| | 0.125 | 2.25 | 0.933 | 0.528 | 0.659 |
| | 0.1875 | 2.125 | 1.362 | 0.733 | 0.917 |
| | 0.25 | 2 | 1.767 | 0.906 | 1.132 |

TABLE 2M

PIPE DIMENSIONS AND PROPERTIES [METRIC]

| Nominal Size in. | Schedule No. | Outside Diam. mm | Wall Thickness mm | Inside Diameter mm | Area mm ² | Section Modulus, S mm ³ | Moment of Inertia, I mm ⁴ |
|------------------|--------------|------------------|-------------------|--------------------|----------------------|------------------------------------|--------------------------------------|
| ¾ | 40 | 26.7 | 2.87 | 20.9 | 215 | 1 160 | 15 400 |
| | 80 | | 3.91 | 18.9 | 280 | 1 400 | 18 700 |
| 1 | 40 | 33.4 | 3.38 | 26.6 | 319 | 2 180 | 36 400 |
| | 80 | | 4.55 | 24.3 | 412 | 2 630 | 44 000 |
| 1¼ | 5 | 42.2 | 1.65 | 38.9 | 210 | 2 050 | 43 300 |
| | 10 | | 2.77 | 36.7 | 343 | 3 180 | 67 000 |
| | 40 | | 3.56 | 35.1 | 432 | 3 860 | 81 300 |
| | 80 | | 4.85 | 32.5 | 569 | 4 780 | 101 000 |
| 1½ | 5 | 48.3 | 1.65 | 45 | 242 | 2 730 | 65 900 |
| | 10 | | 2.77 | 42.8 | 396 | 4 270 | 103 000 |
| | 40 | | 3.68 | 40.9 | 516 | 5 350 | 129 000 |
| | 80 | | 5.08 | 38.1 | 690 | 6 760 | 163 000 |
| 2 | 5 | 60.3 | 1.65 | 57 | 304 | 4 340 | 131 000 |
| | 10 | | 2.77 | 54.8 | 501 | 6 890 | 208 000 |
| | 40 | | 3.91 | 52.5 | 693 | 9 180 | 277 000 |
| | 80 | | 5.54 | 49.2 | 953 | 12 000 | 361 000 |

TABLE 3M

TUBE DIMENSIONS AND PROPERTIES [METRIC]

| Outside Diameter mm | Wall Thickness mm. | Inside Diam. mm | Area mm ² | Section Modulus, S mm ³ | Moment of Inertia, I mm ⁴ |
|---------------------|--------------------|-----------------|----------------------|------------------------------------|--------------------------------------|
| 25 | 1.6 | 22 | 111 | 681 | 8 510 |
| | 3.2 | 19 | 207 | 1 100 | 14 000 |
| 32 | 1.6 | 29 | 144 | 1 090 | 17 400 |
| | 3.2 | 25 | 313 | 1 870 | 29 800 |
| 38 | 1.6 | 35 | 172 | 1 610 | 30 600 |
| | 3.2 | 32 | 330 | 2 830 | 53 900 |
| | 4.8 | 28 | 518 | 3 730 | 71 000 |
| | 6.4 | 25 | 643 | 4 370 | 83 300 |
| 51 | 1.6 | 48 | 233 | 2 950 | 74 900 |
| | 3.2 | 44 | 522 | 5 333 | 136 000 |
| | 4.8 | 41 | 723 | 7 280 | 185 000 |
| | 6.4 | 38 | 909 | 8 840 | 225 000 |
| 64 | 1.6 | 60 | 390 | 4 700 | 149 000 |
| | 3.2 | 57 | 665 | 8 700 | 276 000 |
| | 4.8 | 54 | 927 | 12 100 | 384 000 |
| | 6.4 | 51 | 1150 | 14 900 | 474 000 |

GUIDE SPECIFICATIONS

FOREWARD

These Guide Specifications shall be used as the basis for developing job specifications and shall be edited to fit specific job requirements. Inapplicable provisions shall be deleted, appropriate information shall be provided in the blank spaces and provisions applicable to the job shall be added. *Notes to specifiers are given in italics directly following the paragraphs to which they apply.* Items which represent an option or a choice are enclosed in brackets. Dates given with ASTM and other standards were current at the time this manual was published. Use latest dates when preparing job specifications.

SECTION 05521 - PIPE AND TUBE RAILING SYSTEMS

PART 1-GENERAL

1.01 SCOPE OF WORK

- A. Fabricate and install metal pipe or tube railing systems in accordance with the requirements set forth in this section.

1.02 WORK INCLUDED

- A. Furnish [Carbon steel] [Stainless steel] [Aluminum] [Bronze] pipe and/or tube rails, posts, balusters, newels, panel fillers and fittings for railing systems.

Specify the metal to be used

- B. Fabricate and install railing systems.

1.03 WORK FURNISHED BUT INSTALLED UNDER OTHER SECTIONS

- A. Furnish sleeves and anchors to be cast in concrete to Section [03001 - Concrete] [03300 - Cast-in-Place Concrete].
- B. Furnish sleeves and anchors for embedding in masonry to Section [04300 - Unit Masonry System] [_____ - _____].
- C. Furnish sleeves and anchors for placement in [_____] walls to Section [_____ - _____].

1.04 RELATED WORK SPECIFIED IN OTHER SECTION

- A. Section 03001 - Concrete: Item(s) _____
- B. Section 03300 - Cast-in-Place Concrete: Item(s) _____

For 1.04.A or B specify that tolerances shall be for spacing $\pm \frac{3}{8}$ in. (9mm), alignment $\pm \frac{1}{4}$ in. (6 mm), and plumbness $\pm \frac{1}{8}$ in. (3 mm) of inserts or field drilled holes, and specify that they shall be covered to keep out debris and water subject to freezing.

Refer to ACI standards for concrete construction tolerances.

GUIDE SPECIFICATIONS

C. Section 04300 - Unit Masonry Systems: Item(s) _____

Specify proportions of mortar or grout for filling cells.

D. Section 05120 - Structural Steel: Item(s) _____

Specify tolerance to template and prohibit burning.

Refer to AISC standards for steel construction.

E. Section 06100 - Rough Carpentry: Item(s) _____

Specify adequate backup support for anchoring handrail brackets.

F. Section 09900 - Painting: Item(s) _____

G. Section 106____ - Partitions: Item(s) _____

Specify adequate backup support for anchoring handrail brackets.

1.05 WORK INSTALLED BUT FURNISHED BY OTHERS

A. Section _____ - _____: Item(s) _____

Fill in Section number where specified and items specified.

1.06 STRUCTURAL REQUIREMENTS

A. Railing system shall withstand a minimum concentrated load of _____ pounds (newtons) applied in a direction toward the rail included in an arc of 180 degrees centered over the top of the rail.

Codes vary in method of application and magnitude of load. Governing code shall be checked for specific requirements. NAAMM recommends 200 pounds (890 newtons) minimum concentrated load applied in either a downward or horizontal direction.

Horizontal and vertical concentrated load tests of railing systems shall be conducted in accordance with ASTM E 935.

AND/OR

(But not simultaneously)

A. Railing system shall withstand a minimum uniform load of _____ pounds per foot (newtons per meter) applied [horizontally] [and] [vertically downward], but not simultaneously, on the top rail.

Some codes have requirements for uniform loading on the top rails. Loads shall be applied horizontally or vertically downward or in both directions, but not simultaneously. Governing code shall be checked for specific requirements.

B. Intermediate rails, balusters, and panel fillers shall be designed for a uniform load of not less than _____ lb/sq ft (N/sq mm) over the gross area of the system of which they are a part. Reactions due to this loading shall not be added to the loading specified for the main supporting members of the rails.

Guardrail system is defined as a vertical barrier erected along exposed edges of stairways, balconies, etc. When so designed, a handrail serves as part of a guardrail system. NFPA Life Safety Code requires a minimum uniform load of not less than 25 lb/sq ft (1.2 kPa) for guardrail systems. Governing code shall be checked for specific requirements.

1.07 QUALITY ASSURANCE

A. Fabricator Qualifications

If special or unusual capabilities are required they shall be set forth here.

B. Installer qualifications

State as required in 1.07.A or state specific qualifications required.

C. Regulatory Requirements

Determine code regulations that govern this work. Specify requirements and drawings that are necessary to meet governing codes.

1.08 REFERENCES

A. Aluminum Association (AA)

1. Aluminum Standards & Data
2. Designation System for Aluminum Finishes

B. American Architectural Manufacturers Association (AAMA)

1. AAMA 605.2-1992 Specification for High Performance Organic Coatings on Architectural Extrusions and Panels

C. American Concrete Institute (ACI)

1. Guide to Formwork for Concrete, ACI 347R-94

D. American Institute of Steel Construction (AISC)

1. Manual of Steel Construction

E. American Iron & Steel Institute (AISI)

1. Criteria for Structural Applications of Steel Tubing and Pipe

F. Iron and Steel Society of AIME

1. Steel Products Manual
 - a. Carbon Steel Pipe, Structural Tubing, Line Pipe, etc
 - b. Stainless and Heat Resisting Steels

G. American National Standards Institute (ANSI)

1. ANSI A117.1-1998 Guidelines for Accessible and Usable Buildings and Facilities
2. ANSI A1264.1-1995 Safety Requirements for Workplace Floor and Wall Openings, Stairs and Railing Systems
3. ANSI Z97.1-1984 Glazing Materials Used in Buildings, (Reaffirmed 1994) Safety Performance Specifications

H. American Society of Civil Engineers (ASCE)

1. ASCE 7-98 Minimum Design Loads for Buildings and Other Structures

GUIDE SPECIFICATIONS

- I. American Society for Testing and Materials (ASTM) Standards
 - 1. A 36/A 36M-00a Specification for Carbon Structural Steel
 - 2. A 47-99(A 47M-99) Specification for Ferritic Malleable Iron Castings
 - 3. A 48-94ae1 Specification for Gray Iron Castings
 - 4. A 53/A 53M-00 Specification for Pipe, Steel, Black and Hot-Dipped, Zinc-Coated Welded and Seamless
 - 5. A 123/A 123M-93(1998) Specification for Zinc (Hot-Dip Galvanized) Coatings on Iron and Steel Products
 - 6. A 269-00 Specification for Seamless and Welded Austenitic Stainless Steel Tubing for General Service
 - 7. A 312/A 312M-00c Specification for Seamless and Welded Austenitic Stainless Steel Pipe
 - 8. A 473-99 Specification for Stainless and Heat-Resisting Steel Forgings
 - 9. A 500-99 Specification for Cold-Formed Welded and Seamless Carbon Steel Structural Tubing in Rounds and Shapes
 - 10. A 501-99 Specification for Hot-Formed Welded and Seamless Carbon Steel Structural Tubing
 - 11. A 513-00 Specification for Electric-Resistance-Welded Carbon and Alloy Steel Mechanical Tubing
 - 12. A 554-98e1 Specification for Welded Stainless Steel Mechanical Tubing
 - 13. A 666-00 Specification for Annealed or Cold-Worked Austenitic Stainless Steel Sheet, Strip, Plate, and Flat Bar
 - 14. A 743/A 743M-98ae1 Specification for Castings, Iron-Chromium, Iron-Chromium-Nickel, Corrosion-Resistant, for General Application
 - 15. A 1011/A 1011M-00 Specification for Steel, Sheet and Strip, Hot-Rolled, Carbon, Structural, High-Strength Low-Alloy, and High-Strength Low-Alloy with Improved Formability
 - 16. B 26/B 26M-99 Specification for Aluminum-Alloy Sand Castings
 - 17. B 43-98 Specification for Seamless Red Brass Pipe, Standard Sizes
 - 18. B 62-93 Specification for Composition Bronze or Ounce Metal Castings
 - 19. B 209-00 (B 209M-00) Specification for Aluminum and Aluminum-Alloy Sheet and Plate
 - 20. B 210-00 (B 210M-00) Specification for Aluminum and Aluminum-Alloy Drawn Seamless Tubes
 - 21. B 221-00 (B 221M-00) Specification for Aluminum and Aluminum-Alloy Extruded Bars, Rods, Wires, Profiles, and Tubes
 - 22. B 241/B 241M-00 Specification for Aluminum and Aluminum-Alloy Seamless Pipe and Seamless Extruded Tube
 - 23. B 247-00 (B 247M-00) Specification for Aluminum and Aluminum-Alloy Die Forgings, Hand Forgings, and Rolled Ring Forgings
 - 24. B 429-00 Specification for Aluminum-Alloy Extruded Structural Pipe and Tube
 - 25. B 455-96 Specification for Copper-Zinc-Lead Alloy (Leaded Brass) Extruded Shapes
 - 26. B 483/B 483M-00 Specification for Aluminum and Aluminum-Alloy Drawn Tubes for General Purpose Applications
 - 27. B 584-00 Specification for Copper Alloy Sand Casting for General Applications
 - 28. C 1107-99 Specification for Packaged Dry, Hydraulic-Cement Grout (Nonshrink)
 - 29. E 894-88 (Reapproved 1998) Test Method for Anchorage of Permanent Metal Railing Systems and Rails for Buildings
 - 30. E 935-00e1 Test Methods for Performance of Permanent Metal Railing Systems and Rails for Buildings
 - 31. E 985-00e1 Specification for Permanent Metal Railing Systems and Rails for Buildings
 - 32. E 1481-00a Standard Terminology of Railing Systems and Rails for Buildings
- J. American Welding Society (AWS)
 - 1. ANSI/AWS A5.1-93 Specification for Carbon Steel Covered Arc Welding Electrodes
 - 2. ANSI/AWS A5.3-93 Specification for Aluminum and Aluminum Alloy Electrodes for Shielded Metal Arc Welding
 - 3. ANSI/AWS A5.4-92 Specification for Corrosion-Resisting Chromium and Chromium-Nickel Steel Covered Electrodes

4. ANSI/AWS A5.6-84 Specification for Copper and Copper Alloy Covered Arc Welding Electrodes
 5. ANSI/AWS A5.7-84(Reapproved 1991) Specification for Copper and Copper Alloy Bare Welding Rods and Electrodes
 6. ANSI/AWS A5.9-93 Specification for Corrosion-Resisting Chromium and Chromium-Nickel Steel Bare and Composite Metal Cored and Stranded Arc Welding Electrodes and Welding Rods
 7. ANSI/AWS A5.10-92 Specification for Bare Aluminum and Aluminum Alloy Welding Electrodes and Rods
 8. ANSI/AWS A5.11-90 Specification for Nickel and Nickel-Alloy Covered Welding Electrodes
 9. ANSI/AWS A5.14-89 Specification for Nickel and Nickel-Alloy Bare Welding Rods and Electrodes
 10. ANSI/AWS A5.18-93 Specification for Steel, Carbon, Filler Metals for Gas Shielded Arc Welding
 11. ANSI/AWS A5.20-94 Specification for Carbon Steel Electrodes for Flux Cored Arc Welding
 12. ANSI/AWS A5.22-94 Specification for Flux Cored Corrosion-Resisting Chromium and Chromium-Nickel Steel Electrodes
- K. Copper Development Association (CDA)
1. Standards Handbook, Wrought Copper and Copper Alloy Mill Products, Part 2 - Alloy Data
 2. Standards Handbook, Cast Copper and Copper Alloy Products, Part 7 - Alloy Data
 3. Copper, Brass and Bronze Design Handbook for Architectural Applications
- L. General Services Administration (GSA), Federal Specifications (FS)
1. TT-P-641G(1) Primer Coating; Zinc Dust Oxide (for Galvanized Surfaces)
- M. National Association of Architectural Metal Manufacturers (NAAMM)
1. Metal Finishes Manual (AMP 500-88 through AMP 505-88)
 2. Code of Standard Practice for the Architectural Metal Industry (AMP 555-92)
- N. National Fire Protection Association (NFPA)
1. 101 Life Safety Code
- O. Steel Structures Painting Council (SSPS)
1. SP2 Specification for Hand Tool Cleaning
 2. SP3 Specification for Power Tool Cleaning
- P. Steel Tube Institute of North America (STI)
1. HSS Dimensions & Section Properties

1.09 SUBMITTALS

- A. Shop Drawings
1. Submit shop drawings for all railing systems, including splices and attachments.
 2. Identify location of all railing systems.
 3. Indicate railing systems in related and dimensional position, with elevations at scale of 1/4" = 12" (1:50) and details at scale of 3" = 12" (1:5) or larger.
 4. Show all details and dimensions not governed by field conditions.
 5. Indicate all required field measurements.

B. Optional Items

Only those items required shall be specified in order to avoid unnecessary expense.

1. Railing system samples showing finish.
2. Maintenance instructions.
3. Assembly and installation instructions.
4. Material certifications.
5. Structural calculations.
6. Structural test reports.

GUIDE SPECIFICATIONS

1.10 DELIVERY, STORAGE AND HANDLING

- A. Conform to requirements of Section 016_____.

If project specifications include a section in Division 1 establishing the general requirements for Delivery, Storage and Handling of materials and equipment for the project, include 1.10.A and modify the following paragraphs to avoid duplication.

- B. Deliver materials to the job site in good condition and properly protected against damage to finished surfaces.
- C. Storage on site
1. Store material in a location and in a manner to avoid damage. Stacking shall be done in a way which will prevent bending.
 2. Store aluminum, bronze and stainless steel components and materials in a clean, dry location, away from uncured concrete and masonry. Cover with waterproof paper, tarpaulin or polyethylene sheeting in a manner that will permit circulation of air inside the covering.
- D. Keep handling on site to a minimum. Exercise particular care to avoid damage to finishes of materials.

*Refer to **NAAMM Manual AMP 555-92, Code of Standard Practice for the Architectural Metal Industry, Sections 6 and 7.***

PART 2 - PRODUCTS

2.01 MATERIALS AND FINISHES

- A. Carbon Steel

See page 18, Table 1, for properties of pipe.

1. Structural Plate: ASTM _____

The desired ASTM standard number, e.g. ASTM A 36/A 36M Structural Steel, shall be inserted.

2. Structural Shapes and Bars: ASTM _____

The desired ASTM standard number, e.g. ASTM A 36/A 36M Structural Steel, shall be inserted.

3. Structural Pipe: ASTM _____

The desired ASTM standard number, e.g. A 53/A 53M Pipe, Steel, Black and Hot-Dipped, Zinc-Coated Welded and Seamless, shall be inserted.

Structural grade, not pressure tested, pipe shall be acceptable for structural and architectural applications.

4. Structural Tubing: ASTM _____

The desired ASTM standard number, e.g. ASTM A 500 Cold-Formed Welded and Seamless Carbon Steel Structural Tubing in Rounds and Shapes, shall be inserted.

5. Castings: ASTM _____

The desired ASTM standard number, e.g. ASTM A 47, Grade 32510 (ASTM A 47M, Grade 22010) Ferritic Malleable Iron Castings, or ASTM A 48, Class 30 Gray Iron Castings, shall be inserted.

6. Formed Fittings: ASTM _____

The desired ASTM standard number, e.g. ASTM A 1011/ A 1011M Steel, Sheet and Strip, Hot-Rolled, Carbon, Structural, High-Strength Low-Alloy, and High-Strength Low-Alloy with Improved Formability, Commercial Steel (CS Type B), shall be inserted.

7. Finishes

Refer to NAAMM Metal Finishes Manual for information on all finishes.

- a. Surface Preparation: Remove loose scale, rust, grease, oil, moisture or other foreign materials to properly prepare the surface for subsequent coating application.
 - 1). Remove loose mill scale, rust and dirt following SSPC-SP2 for hand cleaning and SSPC-SP3 for power tool cleaning.
- b. Galvanizing:
 - 1). Products fabricated from shapes, plates, bars and strips shall be galvanized in accordance with ASTM A 123.
- c. Paint: Minimum one coat of rust-inhibitive primer standard with the manufacturer.
- d. Touch-up for Galvanized Surfaces: Use paint primer-meeting FS-TT-P-64:1.

B. Stainless Steel: Grade _____

Specify Grade 304 or 316. Where severe corrosion conditions exist Grade 316 shall be specified.

1. Sheet, Strip, Plate, and Flat Bar: ASTM _____

The desired ASTM standard number, e.g. ASTM A 666 Annealed or Cold-Worked Austenitic Stainless Steel Sheet, Strip, Plate, and Flat Bar, shall be inserted.

2. Pipe and Tubing: ASTM _____

The desired ASTM standard number, e.g. ASTM A 554 Welded Stainless Steel Mechanical Tubing, or ASTM A 312 Seamless and Welded Austenitic Stainless Steel Pipe, shall be inserted.

3. Finish: No. _____

Insert desired finish number.

Refer to NAAMM/AMP 503-88, Finishes for Stainless Steel.

Specify either No. 2D for dull mill finish or No. 4 for general purpose polished finish.

GUIDE SPECIFICATIONS

C. Aluminum

See The Aluminum Association's Aluminum Standards and Data for more information.

1. Extruded Bars, Shapes and Tubes: Alloy _____ meeting ASTM [B 221] [B 221M]

Insert desired Aluminum Association Alloy Designation 6061-T6, 6063-T5 or T52, 6063-T6.

2. Extruded Structural Tube or Pipe: Alloy _____ meeting ASTM B 429

Insert desired Aluminum Association Alloy Designation 6061-T6, 6063 T6.

3. Drawn Tubes: Alloy _____ meeting ASTM B 483/B 483M

Insert desired Aluminum Association Alloy Designation 6061-T6, 6063-T6, 6063-T832.

4. Drawn Seamless Tube and Pipe: Alloy _____ meeting ASTM [B 210] [B 210M]

Insert desired Aluminum Association Alloy Designation 6061-T6, 6063 T6, 6063-T832.

Alloys meeting any of the four foregoing ASTM standards are satisfactory for pipe railing systems. B 429 is perhaps the most often referenced for structural tube and pipe used in railing systems.

Drawn 6063-T832 tube and pipe qualifying for B 210 provide the strength of 6061-T6 with the good anodizing qualities inherent in 6063.

5. Sheet and Plate: Alloy _____ meeting ASTM [B 209] [B 209M]

Insert desired Aluminum Association Alloy Designation 6061-T4 or T6, or other suitable alloy.

6. Die and Hand Forgings: Alloy _____ meeting ASTM [B 247] [B 247M]

Insert desired Aluminum Association Alloy Designation 6061-T6 or other suitable alloy.

7. Castings: Alloy meeting ASTM B 26 / B 26M

8. Finish

Refer to NAAMM/AMP 503-88, Finishes for Aluminum.

- a. Mill or As Fabricated finish.

- b. Anodized finish shall be provided in accordance with AA____ and shall meet requirements of AMAA____.

Fill in the Aluminum Association designation for selected mechanical, chemical and anodic finish.

- c. Painted finish shall be _____ type and _____ color and shall meet the requirements of AAMA 605.1 specification for high performance organic coatings.

Specify the type of coating and color required.

D. Copper Alloys:

Copper alloy designations are those of the Copper Development Association. Refer to CDA's Standards Handbook for properties of these alloys.

- 1. Copper Alloy No. 385 (Architectural Bronze) meeting ASTM B 455 for shapes.

Architectural Bronze Alloy 385 is extruded in the form of bars, standard shapes and special shapes such as handrail mouldings, square and rectangular tubing.

- 2. Copper Alloy No. 230 (Red Brass, 85%) meeting ASTM B 43 for pipe.

Seamless brass pipe in Alloy 230 provides a fair color match with Architectural Bronze Alloy 385.

- 3. Copper Alloy No. C83600 meeting ASTM B 62 and B 584 for sand castings.

- 4. Finish: _____

Refer to NAAMM/AMP 502-88 Finishes for the Copper Alloys.

- a. Apply a protective organic coating of clear lacquer of a type recommended by the Copper Development Association.

This paragraph shall be included where protection of surface finish is required. General information on clear organic coatings is published in the Copper Development Association's Copper Brass Bronze Design Handbook - Architectural Applications. For details see CDA publication Clear Organic Finishes for Copper and Copper Alloys, No. 161/10.

- E. Glass: Type _____, Thickness, _____. Shall conform to the safety requirements of ANSI Z97.1.

Accessories: _____

Insert glass type and thickness. List glazing accessories.

- F. Welding Rods and Bare Electrodes: Select in accordance with American Welding Society specifications for the metal alloys to be welded.

2.02 RAILING SYSTEM

- A. Railing system shall be [permanently anchored] [removable].

If only certain sections are to be removable, so indicate and reference locations on drawings.

- B. Rails [and Posts]

- 1. Fabricate rails [and posts] from [(black) (galvanized) carbon steel] [stainless steel] [(anodized) (painted) aluminum] [bronze] [pipe] [tube] with nominal size _____ in.(mm), conforming to

GUIDE SPECIFICATIONS

2.01.____ and finish in accordance with 2.01.____. [Provide reinforcements compatible with the metal used for posts].

Where rails and posts are the same nominal size specify both in this paragraph. Pipe and tube use different systems of measurement. Refer to Tables 2 and 2M, Pages 27 and 28 of this manual, for information on pipe dimensions. Nominal tube sizes are designated by the outside diameters. Specify the metal required.

List the appropriate paragraphs from 2.01 to which the metal and its finish shall conform. If reinforcements for the posts are required it shall be specified here or in 2.02.C.1.

C. Posts

1. Fabricate posts from [(black) (galvanized) carbon steel] [stainless steel] [(anodized) (painted) aluminum] [bronze] [pipe] [tube] with nominal size ____in.(mm), conforming to 2.01.____ and finish in accordance with 2.01.____. [Provide reinforcements compatible with the metal used for posts].

Use this paragraph only if posts differ from rails in nominal size. Rails and posts shall be made of the same metal and have the same finish. Other commentary same as 2.02.B.1.

D. Fittings

1. Fabricate elbows, tees, splice-connections, end caps, etc. from [carbon steel] [stainless steel] [aluminum] [bronze] conforming to 2.01.____ and finish in accordance with 2.01.____.

Specify fittings by [welding] [pressure fitting] [mechanical fastening] [adhesive bonding].

E. Sleeves and Inserts

1. Furnish only, for installation by others, all necessary [sleeves] [and] [inserts] fabricated from the materials listed below:

Specify the products and materials required. Covers shall be provided over sleeves when installed to keep them clean and dry. Materials used shall be steel, galvanized steel, stainless steel, plastic, removable fiber, cardboard, or foam polystyrene, depending on the railing system and requirements of the installation.

Removable cardboard sleeves shall be permitted for installations requiring the embedment of the posts in concrete.

F. Mounting Flanges and Anchor Plates

1. Fabricate [mounting flanges] [and] [anchor plates] from [steel] [stainless steel] [aluminum] [bronze] conforming to 2.01.____ and finish in accordance with 2.01.____.

Specify the metal and finish required, if any, and refer to appropriate paragraphs in 2.01.

G. Handrail Brackets

1. Metal: _____

Specify steel, stainless steel, aluminum, bronze, cast iron, or malleable iron and finish required. Reference appropriate paragraphs in 2.01.

2. Type: _____

Specify cast, extruded, formed or fabricated.

3. Style: _____

Show manufacturer's catalog number or "as shown on architect's details".

2.08 FILLER METAL

A. Aluminum: AWS [A 5.3-] [A 5.10-]____.

B. Copper Alloys: AWS [A 5.6-] [A 5.7-]____.

For "white metal", nickel and nickel alloys, specify AWS A 5.11 or A 5.14.

C. Carbon steel: AWS [A 5.1-] [A 5.18-] [A 5.20-]____.

D. Stainless steel: AWS [A 5.4-] [A 5.9-] [A 5.22-]____.

Select standard and add current date.

2.09 FASTENINGS

A. Mechanical types:

List types to be used (bolts, nuts, machine screws, toggle bolts, expansion shields, lags bolts, etc.) and for each, specify type, metal, size, thread, head style or other necessary information. Stainless steel fastenings shall be specified for aluminum railing systems.

B. Adhesive: Structural adhesive, _____
as manufactured by _____

Specify by trade name, manufacturer and catalog no. or recognized standard.

C. Grout: Hydraulic-cement (nonshrinkable), ASTM C 1107.

2.10 FABRICATION

- A. Form rail-to-end post connections and all changes in rail direction by [mitered joints] [radius bends].
- B. Remove burrs from all exposed cut edges.
- C. Form elbow bends and wall returns to uniform radius, free from buckles and twists, with smooth finished surfaces, or use prefabricated bends.
- D. Locate intermediate rails equally spaced per code requirements between top rail and finish floor or nosing line of tread.
- E. Close exposed ends of pipe and tubing by welding metal closure in place or by use of prefabricated fittings.
- F. For posts set in concrete, furnish matching sleeves or inserts not less than 5 in.(127 mm) long.

Lengths are dependent upon the loading to which railing system will be subjected.

- G. On posts set on stair stringers, weld posts directly to stringer or weld plate to bottom of post for bolting. Specify stiffener plate as required for strength at base of post.

*For fitted railing system, specify use of standard flange.
Caution: Weld at base of aluminum post decreases post bending strength; structural adequacy shall be checked.*

H. Welding:

- 1. Accurately miter and cope intersections of posts and rails and weld all around.
- 2. Weld joint to match Type _____.

Specify Type 1, 2, 3, or 4 from Table on Page 7.

- I. Provide vent/drain holes at ends of all closed sections of [pipe] [tube] for galvanized or anodized railing systems.
- J. Fabricate joints which will be exposed to the weather so as to exclude water, or provide weep holes where water may accumulate.
- K. Removable railing systems: [slip-fit sleeves] [inserts with nuts or studs] [flange bolted to floor]. Provide chain with eye, snap hook and staple across gap at _____.
- L. Provide [kick plate] [toe board] or metal angle or plate, to extend not less than 4 in. (102 mm) above the walking surface, where required by Code.
- M. Touch up welds and abraded areas on galvanized pipe with zinc-rich paint as specified in 2.01.A.7.d.
- N. If the expected discoloration, due to welding, of anodized aluminum and the resulting color discrepancies are not acceptable, they shall be touched up using an acceptable lacquer.
- O. All welded areas on stainless steel railing systems shall be ground and finished to blend with adjacent areas.

PART 3—EXECUTION**3.01 INSTALLATION**

- A. Provide holes, pre-set sleeves, or inserts of sufficient depth in concrete to develop required post strength. Make hole diameter at least $\frac{3}{4}$ in. (19 mm) larger than O.D. of post.
- B. Ends of aluminum posts to be in direct contact with grout, concrete or masonry shall be coated with bituminous paint or zinc chromate primer.

C. Setting posts:

- 1. Clean dust and foreign matter from sleeves.
- 2. Moisten interior of holes and surrounding surfaces with clean water.
- 3. Prepare and use grout in accordance with manufacturer's directions.

Fast drying grout is preferred. Neither lead nor sulphur shall be used.

- 4. Place posts in position and brace until grout sets.
 - 5. Pour mixture into annular space until it overflows the hole.
 - 6. Wipe off excess and leave $\frac{1}{8}$ in. (3 mm) build-up, sloped away from post.
- D. Set posts plumb and aligned to within $\frac{1}{4}$ in. in 12 feet (1:576).

Tolerance varies, depending on quality of project.

- E. Set rails horizontal or parallel to rake of steps or ramp to within $\frac{1}{4}$ in. in 12 feet (1:576).
- F. Assemble connections end-to-end and splice joints by using internal sleeves, bonded by adhesive or mechanical connectors, or by field welding.

G. Expansion Joints:

- 1. Provide at intervals of not more than ____ feet (meters).

Fill in space required. Expansion joints shall be used on straight runs exceeding 40 feet (12 meters). For aluminum, provide 0.1 in. (3 mm) space for each 20 to 24 foot (6 to 7 meter) length of top rail for each 25° F (14° C) difference between installation temperature and maximum design temperature.

- 2. Provide slip joint with internal sleeve extending 2 in. (51 mm) beyond joint each side.
- 3. Fasten internal sleeve securely to one side.
- 4. Locate joints a distance of 6 in. (152 mm) from posts.

Lesser distance does not provide adequate work space; greater distance creates shear problem.

GUIDE SPECIFICATIONS

- H. Support wall handrails on brackets to withstand design loads as required but not more than _____ feet (meters) on centers.

Spacing shall be not more than 6 ft (1.8 m) for steel pipe, 5 ft (1.5 m) for aluminum and bronze. On hollow partitions, specify proper backup support, which must be in place before plaster or drywall is installed.

3.02 CLEANING

Applicable to aluminum, bronze and stainless steel. Refer to appropriate section of NAAMM /AMP Metal Finishes Manual.

- A. As installation is completed, wash thoroughly using clean water and soap; rinse with clean water.
- B. Do not use acid solution, steel wool or other harsh abrasives.
- C. If stain remains after washing, remove finish and restore in accordance with fabricator's recommendations.

Finish shall not be removed from anodized aluminum. Reanodizing of aluminum shall be done by removing affected railing system components and returning to plant.

- D. Protective wrappings shall not be removed until items are no longer subject to subsequent construction damage, at which time any necessary cleaning shall be performed.

3.03 TREATMENT OF FIELD WELDS, GALVANIZED PIPE

Touch up welds by application of 2 coats of galvanizing repair paint as specified in 2.01.A.7.c.

3.04 CORRECTION OF ERRORS OR DEFECTS

Fabricator shall determine who is to correct error and approve the most efficient and economic method of correction in accordance with Code of Standard Practice for the Architectural Metal Industry.

| | |
|--------------------------|---|
| ANCHOR | Any device used to secure a railing system or its parts to adjoining construction or a supporting member. |
| ANODIZE | To provide a hard, corrosion resistant oxide film on the surface of aluminum, by electrolytic action in which the aluminum being treated serves as the anode. |
| BALUSTER | One of a series of closely spaced upright infill members located between top rail or handrail and bottom rail of a railing system. |
| BEVEL (of Stairs) | See Pitch. |
| CAP | A fitting or plug used to close the end of a pipe or tubular rail, or post, or the top end of a tubular newel. |
| CEMENT | A powdery material which, when mixed with water into a plastic state, will harden in place and act as a binder between particles of sand. Not to be confused with Grout. |
| CONNECTION: | |
| Bonded: | A connection in which an internal sleeve is fastened to the railing system member using an adhesive. |
| Mechanical: | A connection between railing system members made by means other than welding or adhesive bonding. |
| Welded: | A connection made by fusing with an acceptable welding procedure. |
| COPE | To cut away a portion of one member, to either form a close fitting joint with, or provide clearance for, another member. |
| DEFLECTION | A bending displacement of a structural member. |
| EASEMENT (Stairs) | That curved portion of a handrail which forms a transition, in a vertical plane, between a horizontal and an inclined section of the handrail. |
| EXPANSION JOINT | A control joint designed to allow for differential movement of the joining parts due to expansion or contraction. |
| FACE STRINGER | A stringer which supports, on one side, the ends of treads and risers, and is exposed on the other side. |
| FASCIA | The exposed facing of the outer edge of a platform or floor; usually similar in detail to the face stringer. |
| FASCIA MOUNT | See Side Mount. |
| FIELD JOINT | A connection between two adjoining railing system members, made at the time of installation; generally accomplished by the use of an internal mechanical connector or by welding. |
| FLIGHT | An uninterrupted series of steps. |
| FLIGHT RISE | The vertical distance between the floors or platforms connected by a flight. |
| FLIGHT RUN | The horizontal distance between the faces of the first and last risers in a flight. |
| FLUSH FITTING | A pipe or tube fitting having the same outside diameter as the pipe or tube to which it is joined. |

GLOSSARY

| | |
|------------------------------|--|
| GRAB RAIL (GRAB BAR) | A short length of rail located for safety and convenience to assist a person in movement at a specific location. |
| GROUT | A fluid mixture of cement, aggregate and water poured into hollow cells of a wall or floor to encase posts or fittings and bond the units together. |
| GUARDRAIL SYSTEM | A railing system usually located for protection of building occupants at or near the outer edge of a stair flight, ramp, landing, platform, balcony or accessible roof; at a perimeter of any opening or accessible surface, such as an opening for stairway; or at a location where operating condition requires limitation of access to designated area, to guard against accidental fall or injury. See Railing System. |
| HANDRAIL | The member which is normally grasped by the hand for support. This member either is part of the railing system or is mounted on the wall or other building element. It is often, but not necessarily, the top member of the railing system. When part of the stair-rail system it parallels the pitch of stair flight. See Wall Handrail. |
| HANDRAIL BRACKET | A device attached to a wall or other surface to support a handrail. A left-hand handrail bracket is one which is located on the user's left as he ascends the stair. A right-hand handrail bracket is one which is located on the user's right as he ascends the stair. |
| HOT DIP GALVANIZING | The process or result of applying a protective coating to ferrous metal by dipping in a bath of molten zinc. |
| I.P.S. | Iron Pipe Size; a nominal inside diameter dimension of pipe. |
| KICK PLATE | A vertical plate forming a lip or low curb at the open edge of platform or floor, or at the back edge or open end of a tread on an open riser stair. |
| MECHANICAL PROPERTIES | Those properties of a material which characterize its response to applied forces; in general, the properties of strength, stiffness, ductility and elasticity. |
| NEWEL | A post member supporting the end of a rail or serving as a common support for two rails. |
| PERMANENT SET | The extent to which a material is permanently deformed by an applied load after removal of the load. |
| PHYSICAL PROPERTIES | Those properties of a material such as specific gravity or density, electrical and thermal conductivities, and coefficient of thermal expansion, which serve to characterize and distinguish between different kinds of matter. |
| PIPE | A hollow round section of metal, the size of which is usually designated by nominal size in inches (millimeters). See Tables 2 and 2M, Pipe Dimensions and Properties. |
| PITCH | The angle of slope of a rail, measured either in degrees or by the ratio of rise to run. |
| PLATFORM (STAIRS) | A horizontal surface having a dimension parallel to the stringer greater than a tread width and occurring in a stair at the end of a flight or between flights, either at a floor level or between floors. In the latter case it is sometimes referred to as an intermediate platform or landing. |

| | |
|-----------------------|---|
| POST | A vertical supporting member of a rail. |
| PRIMER | The shop coat of paint or prime coat of the protective system. It protects the steel for only a short period of exposure in ordinary atmospheric conditions, and is considered a temporary and provisional coating. |
| RAIL | A horizontal or inclined member of a railing system. See Handrail. |
| RAILING SYSTEM | A framework of a combination of vertical, horizontal, inclined and infill members or panels, supporting a handrail and located on a stair flight, platform or floor as a safety barrier. |
| RETURN | A rail bend of varying angular degrees at a stair platform or rail terminal. See Wall Return. |
| RISE | See Flight Rise. |
| RISER | The vertical or inclined face of a step extending from the back edge of one tread to the outer edge of the tread or lower edge of the nosing next above it. |
| RUN | See Flight Run and Tread Run. |
| SIDE MOUNT | A method of railing system support in which the posts are anchored to a vertical surface such as a fascia or stringer face. Also referred to as fascia bracket or fascia flange. |
| SLEEVE | a) A tubular section placed in concrete or masonry to provide a pocket for the insertion of a post of fitting. b) An internal tubular splice between abutting sections of pipe or tube. See also Field Joint. |
| STEP | The combination of a riser and the tread immediately above it. |
| STRINGER | An inclined structural member supporting a flight, or a structural member having an inclined section with a horizontal section at one or both ends, supporting a flight and one or two platforms. |
| TOE BOARD | See Kick Plate. |
| TOE PLATE | See Kick Plate. |
| TREAD | The horizontal member of a step. |
| TREAD RUN | The horizontal distance between two consecutive risers or, on an open riser stair, the horizontal distance between nosings of the outer edges of successive treads, all measured perpendicular to the front edges of the nosings or treads. |
| TUBE / TUBING | A hollow section of metal having a round, square, rectangular, or other cross-sectional form, its size being designated by outside dimension(s) and wall thickness. See Tables 3 and 3M, Tube Dimensions and Properties. |
| WALL HANDRAIL | A handrail attached to a wall adjacent to a stair and paralleling the pitch of the flight; also used along walkways, ramps, and corridors. Also referred to as a "wall rail." |
| WALL RETURN | A bend at the end of a wall handrail, turning it toward the wall or partition to which it is attached. |

