

Installation, Operation and Maintenance Manual

**WKM<sup>®</sup>**  
**Pow-R-Seal<sup>®</sup> Gate Valve**

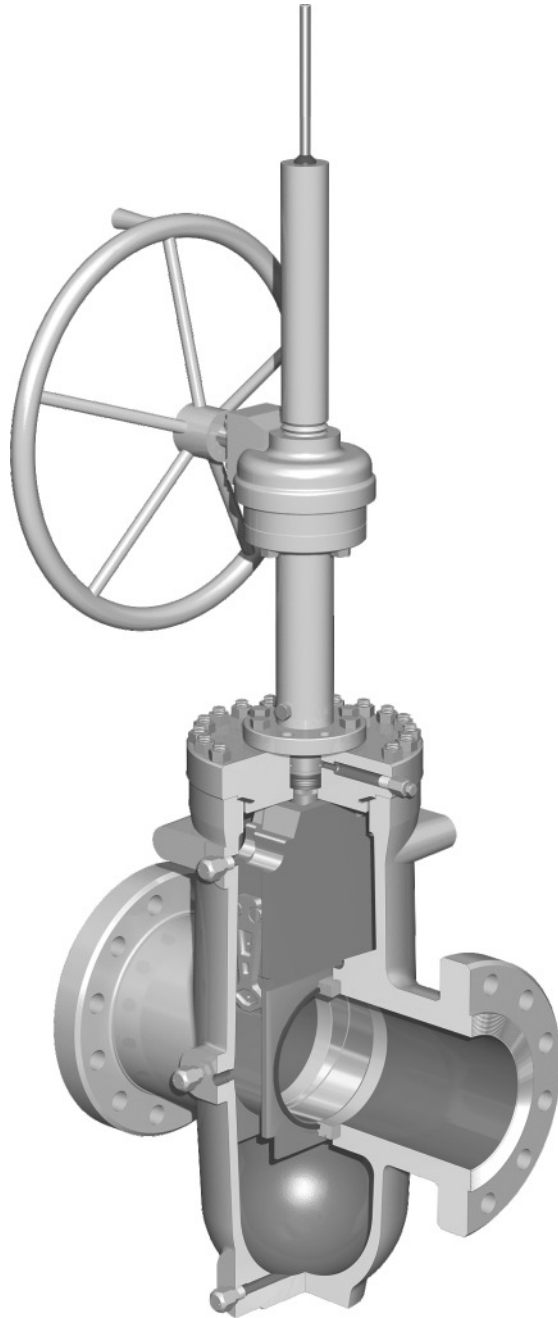

## TABLE OF CONTENTS

### WKM® POW-R-SEAL® GATE VALVE

Bill of Materials	
2"-4" Class 300-1500. ....	3
6"-12" Class 300-900. ....	4
6"-12" 1500, 14"-36" Class 300-900. ....	5
Outside Packing Gland (OS&Y).....	6
Scope .....	7
Nameplate Information .....	7
Storage.....	8
Installation .....	8
Hydrostatic Testing .....	9
Operation .....	10
Routine Maintenance.....	10
Draining Valve .....	11
Low Temperature Precautions .....	12
Lubricating Handwheel and Operation Assembly.....	13
Lubricating Seats.....	13
Maintaining Vee Packing.....	15
Trouble Shooting .....	16

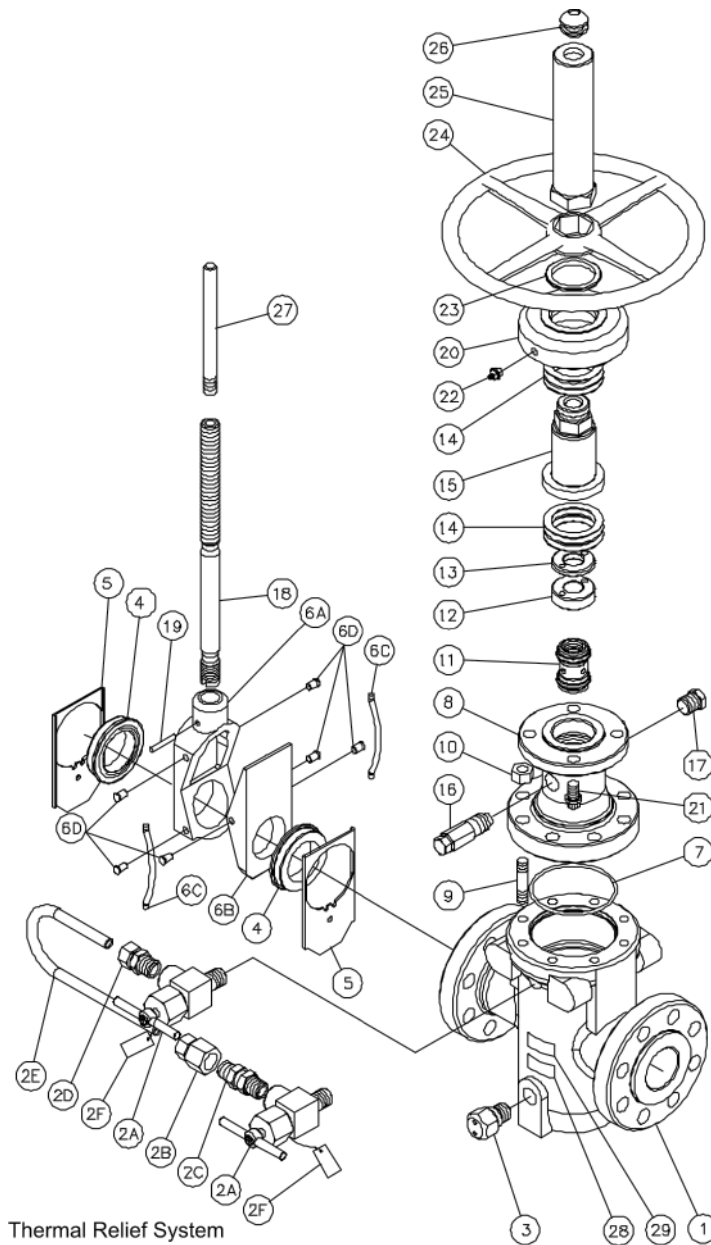
**BILL OF MATERIALS (2" - 4") MODEL "M"**

ITEM	DESCRIPTION
1.	Body
2.	Thermal Relief Valve System
2A.	Needle Valves
2B.	Female Connector
2C.	Check Valve
2D.	Male Connector
2E.	Tubing
2F.	Needle Valve Caution Tag
3.	Drain Fitting
4.	Seats
5.	Seat Skirts
6.	Gate and Segment Assembly
6A.	Gate
6B.	Segment
6C.	Springs
6D.	Spring Pins
7.	Bonnet Seal
8.	Bonnet
9.	Studs
10.	Nuts
11.	Packing Set
12.	Packing Retainer Nut
13.	Packing Retainer Lock Nut
14.	Bearings
15.	Stem Nut
16.	Packing Fitting Assembly
17.	Packing Plug
18.	Stem
19.	Stem Pin
20.	Bearing Housing
21.	Capscrews
22.	Bearing Housing Grease Fitting
23.	Weather Seal
24.	Handwheel
25.	Stem Protector
26.	Rod Wiper
27.	Indicator Rod
28.	Caution Tag for Trapped Pressure
29.	Nameplate

Figure 1 - WKM Pow-R-Seal Gate Valve 2" - 4" ASME Class 300 - 1500

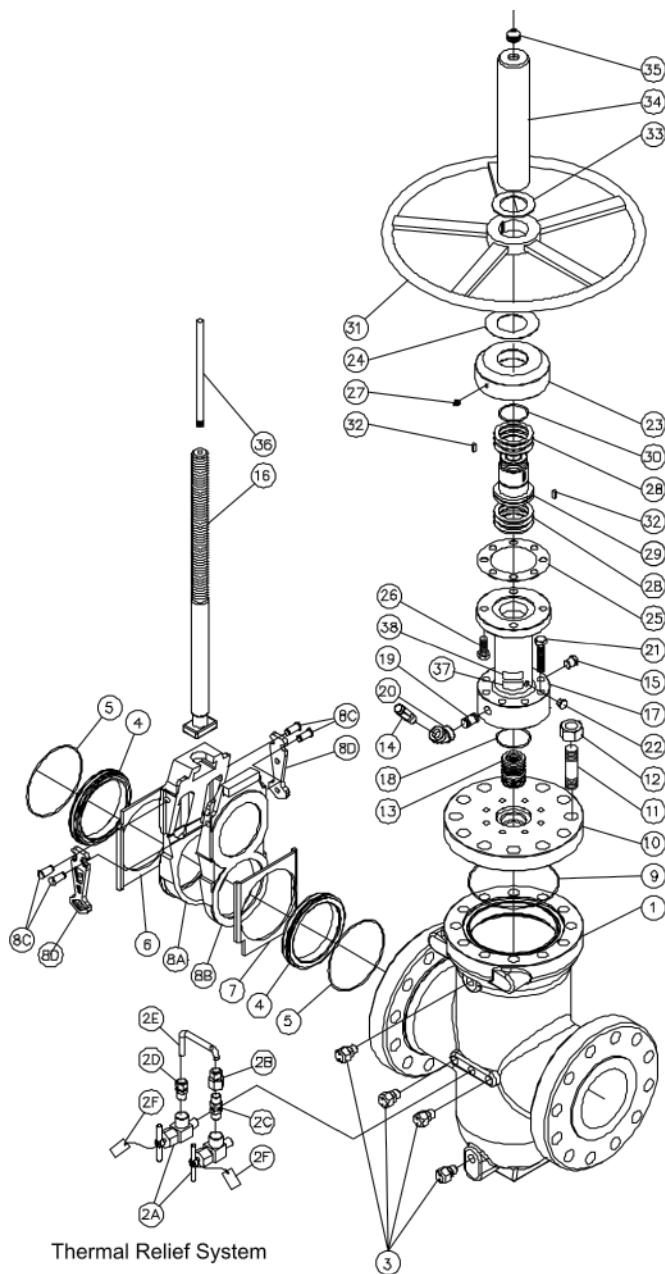
**BILL OF MATERIALS (6" - 12") MODEL "E1A" & "E1C"**

Thermal Relief System

 Figure 2 - WKM Pow-R-Seal Gate Valve 6" - 12"  
 ASME Class 300 - 900

Note: On Model "E1C" the Packing Set is located in the Bonnet and therefore the Packing Injection Port is on the O.D. of the Bonnet.

ITEM	DESCRIPTION
1.	Body
2.	Thermal Relief Valve System
2A.	Needle Valves
2B.	Female Connector
2C.	Check Valve
2D.	Male Connector
2E.	Tubing
2F.	Needle Valve Caution Tag
3.	Vent, Drain and Seat Lube Fitting
4.	Seats
5.	Seat O-Rings
6.	Gate Seat Skirt
7.	Segment Seat Skirt
8.	Gate and Segment Assembly
8A.	Gate
8B.	Segment
8C.	Lever Lock Arm Pins
8D.	Lever Lock Arms
9.	Bonnet Seal
10.	Bonnet
11.	Studs
12.	Nuts
13.	Packing Set
14.	Packing Fitting Assembly
15.	Packing Plug
16.	Stem
17.	Yoke Tube
18.	Yoke Tube Seal
19.	Packing Nipple
20.	Elbow 45°
21.	Hex Head Bolts
22.	Pull Plug
23.	Bearing Housing
24.	Washer
25.	Gasket
26.	Hex Head Bolts
27.	Bearing Housing Grease Fitting
28.	Bearings
29.	Stem Nut
30.	Stem Nut O-Ring
31.	Handwheel
32.	Handwheel Keys
33.	Stem Protector Washer
34.	Stem protector
35.	Rod Wiper
36.	Indicator Rod
37.	Caution Tag for Trapped Pressure
38.	Nameplate

# BILL OF MATERIALS (6" - 12" 1500, 14" - 36" 300 - 900) MODEL "E" & "E1C"

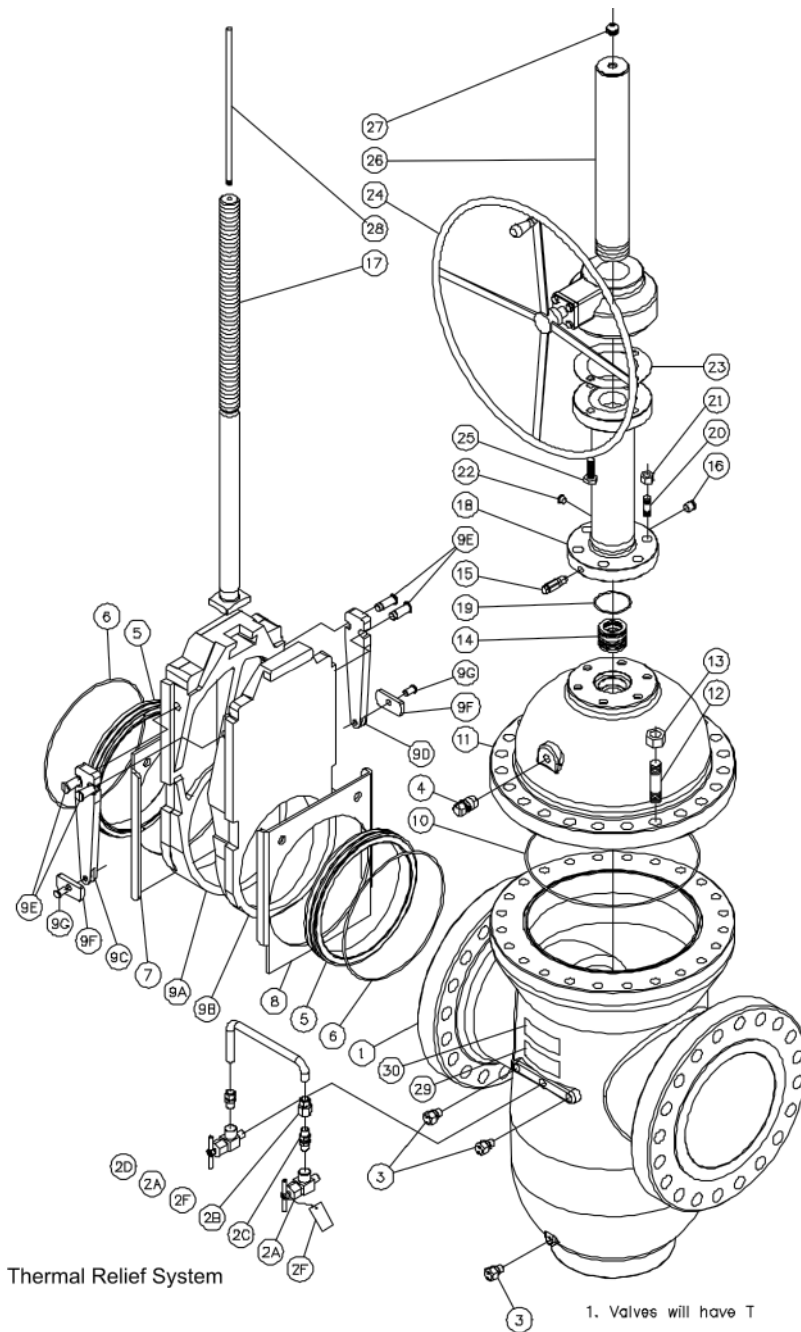

ITEM	DESCRIPTION
1.	Body
2.	Thermal Relief Valve System
2A.	Needle Valves
2B.	Female Connector
2C.	Check Valve
2D.	Male Connector
2E.	Tubing
2F.	Needle Valve Caution Tag
3.	Drain and Seat Lube Fittings
4.	Vent Fittings
5.	Seats
6.	Seat O-Rings
7.	Gate Seat Skirt
8.	Segment Seat Skirt
9.	Gate and Segment Assembly
9A.	Gate
9B.	Segment
9C.	Lever Lock Arm #1
9D.	Lever Lock Arm #2
9E.	Lever Lock Arm Pins
9F.	Lever Lock Shoe
9G.	Shoe Pins
9H.	
9I.	
9J.	
9K.	
9L.	
9M.	
9N.	
9O.	
9P.	
9Q.	
9R.	
9S.	
9T.	
9U.	
9V.	
9W.	
9X.	
9Y.	
9Z.	
10.	Bonnet Seal
11.	Bonnet
12.	Studs
13.	Nuts
14.	Packing Set
15.	Packing Fitting Assembly
16.	Packing Plug
17.	Stem
18.	Yoke Tube
19.	Yoke Tube Seal
20.	Studs
21.	Nuts
22.	Pull Plug
23.	Gasket
24.	Bevel Gear Operator
25.	Hex Head Bolts
26.	Stem Protector
27.	Rod Wiper
28.	Indicator Rod
29.	Caution Tag for Trapped Pressure
30.	Nameplate

Figure 3 - WKM Pow-R-Seal Gate Valve 6" - 12" ASME Class 1500, 14" - 36" 300 - 900.

Note: On Model "E1C" the Packing Set is located in the Bonnet and therefore the Packing Injection Port is on the small O.D. at the top of the Bonnet.

## BILL OF MATERIALS OUTSIDE PACKING GLAND (OPG OR OS&Y) OPTION

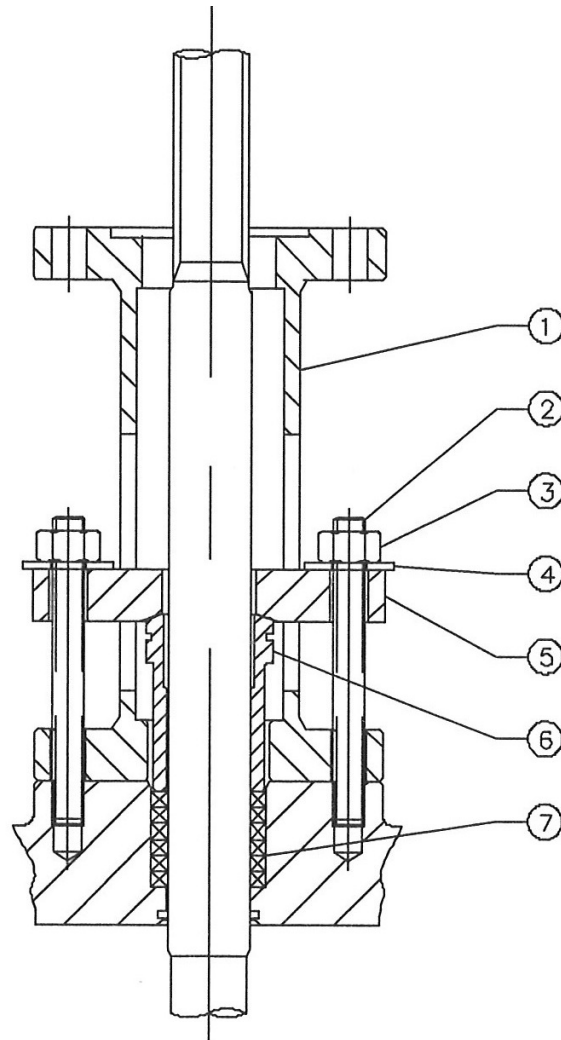

Figure 4 - Outside Packing Gland (OPG) Stem Seal Arrangement

ITEM	DESCRIPTION
1.	OPG Yoke Tube
2.	Studs
3.	Nuts
4.	Lock Washer
5.	Follow Plate
6.	Packing Gland
7.	Packing Rings

## SCOPE

This manual covers all bolted bonnet Pow-R-Seal Gate Valves. Drawings shown are typical. The design of specific valves may vary slightly from the drawings.

The Pow-R-Seal Gate Valve is a premium through conduit parallel expanding gate valve. The parallel expanding gate design provides a tight mechanical seal which is normally unaffected by pressure variations. The full-bore design has the same pressure drop as an equivalent length of pipe and allows passage of all types of scrapers (pigs).

The Pow-R-Seal Gate Valve is designed with positive stops that do not need adjustment. The valve can be repaired while in line (pressure removed and valved drained).

The stem is sealed either by Chevron packing or spring-loaded lip seals. In an emergency, plastic packing can be injected into the packing box to affect a temporary seal while the valve is under pressure.

Outside packing gland stem seals are offered for high temperatures up to 1000°F (588°C).

Pow-R-Seal Gate Valves do not depend on lubricant for a seal in normal operation. However, lubricant and sealants can be injected to promote smooth operation. Seat sealant can also be injected to affect a seal in an emergency should the seats become damaged by foreign matter.

Seats with all metal seats are available in special trims. Because of the split gate design, it is possible for excess body pressure to develop in the valve body cavity. A body cavity thermal relief system is provided to relieve this excess body pressure.

Pow-R-Seal Gate Valves are available in sizes, pressure classes, materials and coatings that meet industry requirements. Valves are available with lubrication/packing/drain extensions and stem/yoke tube extensions.

## NAMEPLATE INFORMATION

### ITEM STAMP

1. Nominal Valve Size
2. Maximum Cold Working Pressure (psig)
3. \*Serial Number
4. API Class Designation
5. Maximum Temperature in °F
6. \*Bill of Material Number
7. Body Material Designation
8. Stem Material Designation
9. Gate Material Designation
10. Seat Material Designation
11. (Maximum Operating Pressure at 250°F - if Applicable)
12. (API Monogram - if Applicable)
13. Model Designation
14. (Marking for Non-Standard End-to-End - if Applicable)
15. (License Number - if Applicable)
16. Date of Manufacture
17. (Impact Test Temperature - if Applicable)

( ) Descriptions in parenthesis may be left blank in some cases.  
 \* Most important data for obtaining correct replacement parts. Nameplate may vary.

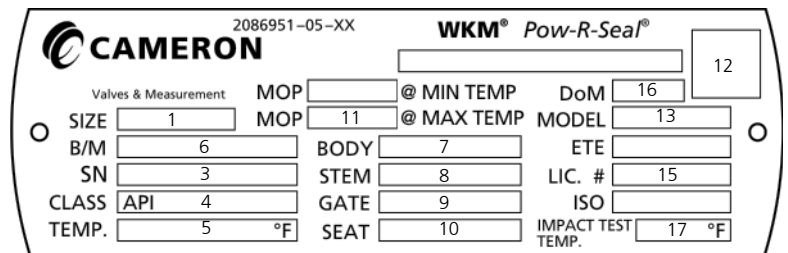

Valves & Measurement		MOP	@ MIN TEMP	DoM	16	12
SIZE	1	MOP	11	@ MAX TEMP	MODEL	13
B/M	6	BODY	7	ETE		
SN	3	STEM	8	LIC. #	15	
CLASS	API 4	GATE	9	ISO		
TEMP.	5 °F	SEAT	10	IMPACT TEST TEMP.	17 °F	

Figure 5 - Typical Power-R-Seal Nameplate

## STORAGE

After WKM Pow-R-Seal Gate Valves are assembled and tested, the valves are left in the full open position, seats and bores are greased and end protectors are installed. These measures will provide protection for approximately six months. The following care should be taken when storing valves:

1. Make sure the valve end connection covers remain in place during storage.
2. If the valve does not have an operator and the valve will be stored outside, the exposed stem

or the stem adapter should be covered to avoid accumulation of water and debris.

If long-term storage is required, the valve should be conditioned by following Cameron procedure X-150771-01. Ensure adequate end connection covers are in place. Request a copy of X-150771-01 from Cameron's Valves & Measurement group.

## INSTALLATION

Install Pow-R-Seal Gate Valves into the line with the preferred pressure flange end or weld end (marked with red paint from the factory) as the upstream side. When handling or installing the valve, keep the valve in the full open position whenever possible to prevent foreign matter damage to the gate and seat sealing surfaces. The valve should be lifted in such a way that the body supports the load or use lifting lugs, if provided.

**Caution: Do not use handwheels or other protruding parts of the valve, gearbox or actuator to lift the valve. During handling, use care to avoid damaging the end connection faces, fittings and bypass relief systems. The end connection necks are suitable places to attach lifting slings, if lifting lugs are not on the valve.**

Flanged-End valves may be bolted into line using two open or boxed end wrenches. Power wrenches may be required for larger valves. Make sure the line flanges are properly aligned and will not distort or bind the valve. Use new flange gaskets.

1. Bolt and nut threads should be lubricated to obtain proper loading of bolts.
2. Finger-tighten all nuts first.
3. Tighten bolts, using the crisscross method and torque each bolt to ASME or gasket manufacture's specifications.

Butt Weld-End Valves should be welded into the line by qualified welders, using qualified procedures. Cameron Valves & Measurement recommends that all welding procedures and welders be qualified per ASME Section IX.

**Caution: Keep weld end valves open while installing/welding into the line. Weld slag created during the welding process could damage gate sealing surfaces.**

1. Use solvent to clean grease or rust inhibitor from the gate and/or bore of the valve.
2. Make sure the line and valve weld bevels are properly aligned, and will not bind the valve.
3. Electric welding equipment is preferred for all installations. However, if only oxygen-acetylene welding equipment is available, extreme caution should be taken regarding excess welding temperature to prevent damage to sealing components of the valve.
4. Weld with the gate in "Full Open" position.
5. Make sure temperature of the body/seat area does not exceed 250°F. (Check with Tempil stick or equivalent).
6. Avoid rapid application of excess welding material. Weld each end of the valve with a continuous bead using a 1/8" maximum diameter electric welding rod.
7. Keep the valve in the "Full Open" position until the line has been thoroughly cleaned of weld slag in the valve bore and line (by pigging and/or flushing) before changing the position of the gate.

Pow-R-Seal Gate Valves in liquid service must have a body thermal relief system (needle valves, if present, must be in the open position prior to operation of valve) installed on the valve.

**Caution: Failure to install a properly set body thermal relief system on the valves in liquid service may cause rupturing of the body resulting in catastrophic release of pressure.**



## HYDROSTATIC TESTING

Pow-R-Seal Gate Valves in liquid service must have a body thermal relief system (needle valves, if present, must be in the open position prior to operation of valve) installed on the valve.

**Caution: Failure to install a properly set body thermal relief system on the valves in liquid service may cause rupturing of the body resulting in catastrophic release of pressure.**

1. The valve should be in a fully open position when the injection of test fluid begins. This will allow any pipeline debris to be flushed through the valve bore and out of the piping.
2. Once the piping system has been purged of debris and the system has been filled completely with the test fluid, the gate should be placed in the partially open position to allow test fluid into the body cavity of the valve.
3. The valve is now ready to be hydrostatically pressure tested.
4. Upon completion of the hydrostatic testing, the valve should be returned to the fully open position before removing the test fluid from the piping system. The test fluid in the body cavity can be drained through the body drain port located in the lower portion of the valve body. (See Draining Valve, Page 13).
5. Close the valve body bleed fitting and return the valve to the required operating position, either fully open or fully closed.
6. If the valve is equipped with seat injection fittings, the valve seat pockets should be filled with an approved valve lubricant to displace any test fluid from behind the seats.
7. Some WKM T-11 or T-102 trim valves having Vee packing should be repacked after hydrostatic testing with water. Follow the procedure in the Troubleshooting section of this manual for repacking the stem seal. Use WKM #113 or Jim Ray TIGER PAK FF plastic packing.

**Caution: Do not exceed pressures listed below. Test pressures are per API 6D and are not operating pressures. The Maximum Allowable Operating Pressure (MAOP) is marked on the nameplate.**

Pressure Class	Hydrostatic Shell psig (barg)	Hydrostatic Seat psig (barg)
150	425 (29.3)	300 (20.7)
300	1100 (75.9)	800 (55.2)
600	2175 (150)	1600 (110)
900	3250 (224)	2400 (166)
1500	5400 (372)	4000 (275)
2500	9000 (620)	6600 (455)

## OPERATION

The Pow-R-Seal Gate Valve may be operated with a handwheel or may be power actuated. With either mode of actuation, open and close valve completely. **DO NOT THROTTLE FLOW.** The valve, in good condition, will seal pressures up to the maximum allowable working pressure as a block valve, single block-and-bleed valve or a double-block-and-bleed valve.

Valves equipped with handwheels are **CLOSED** by turning the handwheel **CLOCKWISE** until it becomes tight. Tighten securely to mechanically energize the seal. **DO NOT BACK OFF THE HANDWHEEL.** The indicator rod at the top of the valve will move down (towards the valve bore), as the handwheel is turned

**CLOCKWISE.** The valve is **OPENED** by turning the handwheel **COUNTER-CLOCKWISE** until it contacts the stop. The indicator rod at the top of the valve will move up (away from the valve bore), as the handwheel is turned **COUNTER-CLOCKWISE.**

When valves are equipped with power actuators, the movement of the indicator rod will indicate if the valve is being opened or closed. Make sure all accessories recommended by the actuator manufacturer are installed before valve actuator installation. Should any maintenance be necessary, obtain the part number from the unit's nameplate and contact Cameron Valves & Measurement or the nearest representative.

## ROUTINE MAINTENANCE

The following outlines the minimum scheduled maintenance required for Pow-R-Seal Gate Valves to promote trouble-free service and long life. Some applications may require more maintenance. Visually inspect every six months. See trouble shooting section (page 13) for temporary solution to problems. Operate the valve once a month, if practical. A full open-close cycle is preferable. Operate a partial cycle as a minimum.

**Caution: Verify compatibility of any sealant, lubricant, or anti-freeze with the trim of the valve and product in the line.**

### Thermal Relief System Maintenance

Pow-R-Seal Gate Valves equipped with a thermal relief system.

1. Inspect relief systems at least twice a year for any visual abnormalities such as damage that may prevent the system from functioning properly. Repair or replace, as required to correct abnormalities.
2. Check valves shall be tested periodically to verify proper function. Follow local piping codes and plant/facility maintenance and safety procedures for the testing frequency. Cameron Valves & Measurement recommends testing check valves using the same schedule for relief valves per ASME B31.4 in the absence of local testing frequency requirements. Make sure needle valves in thermal relief systems are open before returning the valve to service.

## DRAIN VALVE

After lengthy service, there is a possibility of water, line scale, sediment or other foreign matter collecting in the lower body cavity. It is advisable to periodically drain the valve to discourage development of conditions that can possibly lead to valve damage or impair the operation of the valve. If draining is not regularly scheduled, it is strongly recommended to drain the valve at these times:

1. After hydrostatic testing.
2. After cleaning the line.
3. When valve cannot be fully opened or closed (foreign matter in the bottom of valve can not only prevent placing valve in a fully closed position, it can also cause permanent damage to the internal sealing surfaces). A safety pressure releasing tool is required to simplify the procedure of releasing body pressure or draining the valve. To release body pressure or to drain valve, first place the valve in closed position.

**Warning: To avoid possibly being struck by liquid or foreign solid matter, position yourself so the outlet port of the grease fitting is pointing safely away from you. (If the ball check is not holding pressure,**

**pressure will blow through the safety holes in the cap.) Back-up the seat grease fitting using a wrench so only the safety cap will be removed from the fitting. Carefully remove the safety cap from the seat grease fitting. NEVER remove the grease fitting with the valve under pressure!**

Carefully remove the safety cap of the lower drain grease fitting. Contact your local Cameron Valves & Measurement representative for further assistance, if needed. Back out the stinger of the pressures releasing tool until it stops. Install the pressure releasing tool onto the uncapped grease fitting. Carefully screw the stinger of the releasing tool - (until the ball check in the grease fitting is pushed off its seat). This will allow the valve to drain or to release body pressure. After completion, back out the stinger of the pressure releasing tool to allow the ball check in the grease fitting to reseat and permit easy removal of the pressure releasing tool. Replace safety cap on the lower drain grease fitting.

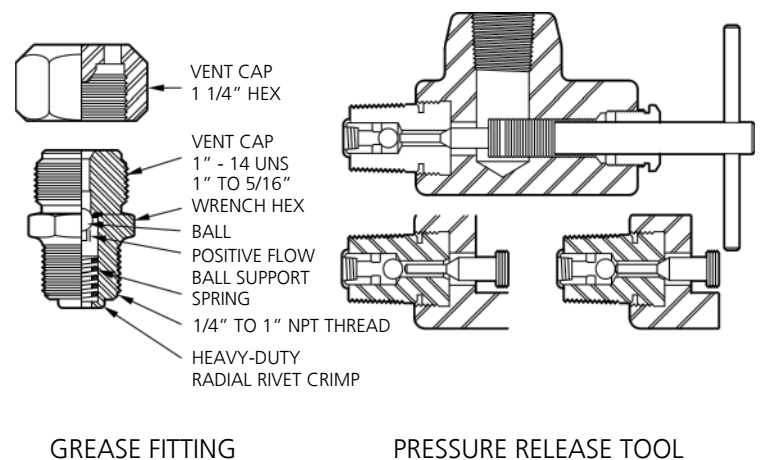

## LOW TEMPERATURE PRECAUTIONS

Prior to exposure to freezing temperatures it is highly recommended the valve be drained.

Water that may be trapped in the body cavity could freeze and impair the operation of the valve or damage the valve.

If the valve has a grease fitting in the lower drain, a sufficient amount of anti-freeze injected into the body cavity via the lower drain grease fitting will prevent accumulated water from freezing.

It is also advisable to inject a sufficient amount of valve lubricant into the grease fittings of the valve and operator (if present) prior to extended cold temperatures exposure.

Trapped water should be drained from stem extensions. Some stem extensions in the field are equipped with plastic plugs that can be removed to drain trapped water from the piped extension.

## VOLUME OF ANTI-FREEZE (ETHYLENE GLYCOL) TO PREVENT FREEZING

Minimum Expected Temperature Value (Percent Anti-Freeze)	18°F / -8°C (18%)	13° / -11°C (23%)	7°F / -14°C (28%)	8°F / -22°C (37%)	28°F / -33°C (48%)
2"	0.3 Gallons (1.0 Liters)	0.3 Gallons (1.3 Liters)	0.4 Gallons (1.6 Liters)	0.6 Gallons (2.1 Liters)	0.7 Gallons (2.7 Liters)
2 ½"	0.3 Gallons (1.0 Liters)	0.3 Gallons (1.3 Liters)	0.4 Gallons (1.6 Liters)	0.6 Gallons (2.1 Liters)	0.7 Gallons (2.7 Liters)
3"	0.4 Gallons (1.4 Liters)	0.5 Gallons (1.7 Liters)	0.6 Gallons (2.1 Liters)	0.7 Gallons (2.8 Liters)	1.0 Gallons (3.6 Liters)
4"	0.5 Gallons (2.0 Liters)	0.7 Gallons (2.6 Liters)	0.8 Gallons (3.2 Liters)	1.1 Gallons (4.2 Liters)	1.4 Gallons (5.5 Liters)
6"	1.0 Gallons (3.8 Liters)	1.2 Gallons (4.5 Liters)	1.4 Gallons (5.3 Liters)	1.9 Gallons (7.2 Liters)	2.4 Gallons (9.1 Liters)
8"	1.8 Gallons (6.8 Liters)	2.3 Gallons (8.7 Liters)	2.8 Gallons (10.6 Liters)	3.7 Gallons (14.0 Liters)	4.8 Gallons (18.2 Liters)
10"	2.7 Gallons (10.2 Liters)	3.5 Gallons (13.1 Liters)	4.2 Gallons (15.9 Liters)	5.6 Gallons (21.0 Liters)	7.2 Gallons (27.3 Liters)
12"	4.0 Gallons (15.0 Liters)	5.1 Gallons (19.2 Liters)	6.2 Gallons (23.3 Liters)	8.1 Gallons (30.8 Liters)	10.6 Gallons (40.0 Liters)
14"	5.4 Gallons (20.4 Liters)	6.9 Gallons (26.1 Liters)	8.4 Gallons (31.8 Liters)	11.1 Gallons (42.0 Liters)	14.4 Gallons (54.5 Liters)
16"	7.4 Gallons (27.9 Liters)	9.4 Gallons (35.7 Liters)	11.5 Gallons (43.5 Liters)	15.2 Gallons (57.4 Liters)	19.7 Gallons (74.5 Liters)
18"	9.9 Gallons (37.5 Liters)	12.7 Gallons (48.0 Liters)	15.4 Gallons (58.3 Liters)	20.4 Gallons (77.0 Liters)	26.4 Gallons (100 Liters)
20"	12.4 Gallons (47.0 Liters)	15.9 Gallons (60.0 Liters)	19.3 Gallons (73.1 Liters)	25.5 Gallons (96.6 Liters)	33.1 Gallons (125 Liters)
22"	14.8 Gallons (55.9 Liters)	18.9 Gallons (71.4 Liters)	23.0 Gallons (86.9 Liters)	30.3 Gallons (115 Liters)	39.4 Gallons (149 Liters)
24"	18.0 Gallons (68.1 Liters)	23.0 Gallons (87.1 Liters)	28.0 Gallons (106 Liters)	37.0 Gallons (140 Liters)	48.0 Gallons (182 Liters)
26"	22.5 Gallons (85.2 Liters)	28.8 Gallons (109 Liters)	35.0 Gallons (132 Liters)	46.3 Gallons (175 Liters)	60.0 Gallons (227 Liters)
28"	27.7 Gallons (105 Liters)	35.4 Gallons (134 Liters)	43.1 Gallons (163 Liters)	57.0 Gallons (216 Liters)	73.9 Gallons (280 Liters)
30"	34.6 Gallons (131 Liters)	44.2 Gallons (167 Liters)	53.8 Gallons (204 Liters)	71.0 Gallons (269 Liters)	92.2 Gallons (349 Liters)
36"	96.3 Gallons (365 Liters)	123 Gallons (466 Liters)	150 Gallons (567 Liters)	198 Gallons (749 Liters)	257 Gallons (972 Liters)

## LUBRICATING HANDWHEEL AND OPERATOR ASSEMBLY

**Handwheel Operated Valves** - Connect a grease gun containing NLGI grade 2 petroleum base grease to the 1/8" Alemite type grease fitting on the bearing housing. Pump in a small amount of grease. DO NOT OVERFILL.

**Bevel Gear Operated Valves** - Bevel gears are supplied by other manufacturers. Consult particular manufacturer's instructions. If these are not available, lubricate the same as Handwheel Operated Valves above.

**Motor Operated Valves** - Motor operators are supplied by other manufacturers. Consult particular manufacturer's instructions. Lubricating Seats (6" and larger valves equipped with seat sealant ports). Lubricate once a year.

1. Only use grease guns that are equipped with a pressure gage.
2. Some seat sealants become very stiff or viscous in cold weather. It may be difficult to pump some sealants under these conditions. It is recommended that the grease gun be kept in a heated area until it is ready to be used. If this is not possible, contact your local Cameron Valves & Measurement representative for low temperature sealant recommendations.
3. Move the valve to the closed position.
4. Carefully, remove the safety caps on the seat lubrication fitting using a wrench.

**Warning: Back-up the seat grease fitting using a wrench so only the safety cap will be removed from the fitting. Carefully remove the safety cap from the seat grease fitting. NEVER remove the grease fitting with the valve under pressure!**

5. Connect the grease gun to the seat lubrication fitting(s). (Both sets may be lubricated at the same time)
6. Pump the sealant into the seat. Once the pressure rises above the valve rated pressure, hold for three (3) minutes to promote filling of the grease grooves.

**NOTE: Grease guns can develop pressures far in excess of the valve working pressure. Use only grease guns, which are equipped with pressure gages. Do not exceed the valve maximum allowable working pressure.**

7. Stroke the valve to spread the sealant on the seat surfaces. (Indicator rod should move approximated 1" or 25 mm.)
8. Release the pressure in the grease gun and remove it from the grease fitting. The fitting ball check should prevent the release of the valve grease pressure.
9. Install the fitting safety cap and tighten securely.
10. Repeat for the other seat. Both seats may be lubricated at the same time, if desired.

## RECOMMENDED LUBRICANT & SEALANT

Trim	Normal Seat Lubricant	Emergency Seat Sealant	Bearing Lubricant	Stem Packing
T-11, T-102, T-94 (Aromatic Hydrocarbons and refined products)	WKM #58G or VAL-TEX 700	WKM #58G	NLGI Grade 2 Bearing Grease	WKM #113 or JIM RAY TIGER PAK FF
T-24, T-10 (Sour Oil and Gas, Waterflood)	VAL-TEX 700	WKM #102	NLGI Grade 2 Bearing Grease	WKM #109
T-08, T07 (Geothermal water and Steam)	NONE	NONE	NLGI Grade 2 Bearing Grease	WKM #115
T-30, T-31 (High temperature steam and hydrocarbon products)	NONE	NONE	NLGI Grade 2 Bearing Grease	NONE
T-36, T-37 (Low temperature produced hydrocarbons)	VAL-TEX 50	WKM #103	WKM #1	WKM #109
T-88 (Anhydrous Ammonia Products)	NLGI Grade 2 Bearing Grease	NLGI Grade 2 Bearing Grease	NLGI Grade 2 Bearing Grease	JIM RAY TIGER PAK A

Product	Manufacturer
WKM 1 WKM 58G WKM 102 WKM 103 WKM 109 WKM 113 WKM 115	<b>Cameron Valves &amp; Measurement</b> 3250 Briarpark Drive, Suite 300 Houston, TX 77042 281.499.8511 1.800.323.9160 281.261.3615 (fax)
Val-Tex 700 Val-Tex 50	<b>Val-Tex</b> 10600 Fallstone Road Houston, TX 77009 800.627.9771 281.530.4848 281.530.5225 (fax)
Jim Ray Tiger Pak FF Jim Ray Tiger Pak A	<b>Jim Ray</b> 10645 Richmond Ave. #130 Houston, TX 77042 713.785.5055 713.785.5534 (fax)

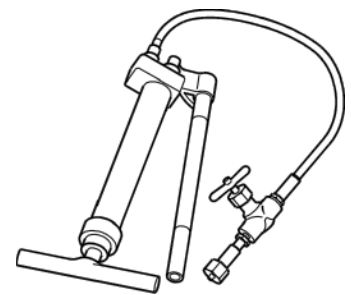

**Figure 11** - Screw/Prime Hand Gun, Part Number 2122495-01. Exact configuration may vary from illustration.

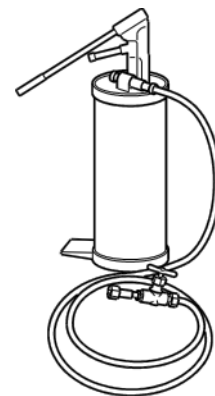

**Figure 12** - Bucket-Type Gun, Part Number K065189. Exact configuration may vary from illustration.

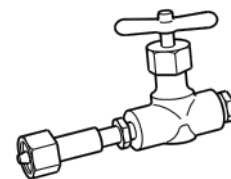

**Figure 13** - Adapter Fitting, Part Number K296434

## Maintaining Vee-packing

(If so equipped) - Once a year or more often as required.

1. Valves equipped with Chevron Vee Packing may require periodic inspection and maintenance to preclude stem leakage. This is particularly important if the valves are in service at temperatures above 250°F (121°C).

2. Other designs use a self-adjusting stem seal and require only periodic inspection.

3. Inspect the valve for evidence of stem leakage. This might be determined by paint discoloration

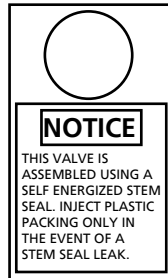

around the bonnet-yoke tube joint. If there is no evidence of leakage, no maintenance is required. It is often beneficial to add one stick of packing once a year to help keep the packing pliable and prevent future problems. (Couple of "sticks" for larger valves)

4. If leakage is evident, inject plastic packing. See the Trouble Shooting Section.

Stick Method	Gun Method
<p><b>Note:</b> Packing is not damaged by cold. However, keep plastic packing in a warm place (like a heated room or vehicle cab) until ready for use to keep pliable</p>	
<ul style="list-style-type: none"> <li>• Remove the injection stinger from the packing fitting. <b>CAUTION:</b> pressure may be trapped in the packing box</li> <li>• Apply a good grade of earing grease to the threads</li> <li>• Place a stick of packing Into the fitting and screw in the stinger until it seats</li> <li>• Repeat as necessary. Use screw torques as follows:                             <ul style="list-style-type: none"> <li>• 3-4 ft-lb (40-50 in-lb, 4-5.5 N-m) for WKM packings</li> <li>• 4-5 ft-lb (50-60 in-lb, 5.5-7 N-m) for thick packings</li> <li>• Do not exceed 7 ft-lb (60 in-lb, 9.5 N-m) as this may exceed the 10,000 psig (689 barg) rating of the fitting</li> </ul> </li> <li>• Back out the screw until the threads show. This allows the bail check to seat</li> </ul> <p><b>CAUTION:</b> Apply only enough packing to stop the leak</p>	<ul style="list-style-type: none"> <li>• Remove the injection stinger from the packing fitting. <b>CAUTION:</b> pressure may be trapped in the packing box</li> <li>• Assemble the packing gun with the appropriate plastic packing</li> <li>• Connect the gun to the packing fitting</li> <li>• Apply 5500-7500 psi (379-517 bar) to the packing gun. Thick packings may require 8000-9000 psi (551-620 bar) <b>CAUTION:</b> The WKM style packing gun applies twice the hand pump pressure</li> <li>• Hold for several minutes</li> <li>• Add more plastic if the pressure drops</li> <li>• Repeat until the packing pressure holds steady</li> <li>• Do not exceed 10,000 psi (689 bar)</li> <li>• Remove the packing gun</li> <li>• Dig out any excess packing from the packing fitting</li> <li>• Apply a small amount of bearing grease to the packing fitting screw</li> <li>• Install the packing fitting screw and tighten</li> </ul>

## TROUBLESHOOTING

Trouble	Probable Cause	Remedy
	The stem seal is leaking due to a contaminated stem.	Cycle the valve several times.
Leakage is occurring around the stem, yoke tube drain, or yoke tube to bonnet joint	The stem seal is leaking due to damage or abnormal wear.	<p>ALL VALVES EXCEPT THOSE WITH OUTSIDE PACKING GLANDS (OPG/OS&amp;Y)</p> <p>Inject plastic packing as follows: Remove the packing fitting screw and install a packing injection gun<sup>1</sup> loaded with the proper plastic injectable. Refer to the "Recommended Lubricants and Sealants" (chart).</p> <p>Using the packing gun, pump plastic to energize the packing set. 4000-5000 psig (275-345 barg) is usually sufficient. DO NOT EXCEED 10,000 psig (690 barg)</p>
Leakage is occurring around the stem, yoke tube drain, or yoke tube to bonnet joint.	The stem seal is leaking due to damage or abnormal wear.	<p><b>WARNING: THE INJECTION PRESSURE IS TWICE THE HYDRAULIC GAUGE PRESSURE.</b></p> <p>Hold for at least 3 minutes. Re-pressurize, as needed.</p> <p>Remove the packing gun.</p> <p>Lubricate the packing fitting screw thread with a good grade of bearing grease. Thread it into the fitting. Tighten securely but do not exceed 7 ft-lbf of torque. (9.5 N-M).</p> <p>VALVES WITH OUTSIDE PACKING GLANDS (OPG)</p> <p>Tighten the gland bolts in an alternating crossing pattern to stop the leak. Do not over tighten.</p>
The Grease fitting or bleed plug is leaking.	The safety cap or bleed plug screw is loose.	Tighten the safety cap or bleed plug screw.
The valve is leaking around bonnet to body joint.	The bonnet seal is leaking.	Insure that the bonnet nuts are tightened properly. Call CAMERON VALVES & MEASUREMENT representative if leakage persists.
A restriction is present in the valve bore.	The gate is not properly aligned with the seats.	<p>HANDWHEEL OR BEVEL GEAR OPERATED VALVES: Open the valve fully by turning the handwheel counter-clockwise. Tighten securely.</p> <p>DO NOT BACK OFF THE HANDWHEEL.</p> <p>MOTOR OPERATED VALVES: Make sure the operator limit switches are set correctly.</p>
The valve will not open or close.	The valve is pressure locked <sup>2</sup> .	Vent the body pressure by using a pressure releasing tool on one of the body vent fittings.
The valve is hard to operate.	The lubrication is not sufficient.	Lubricate the bearings, operator, and/or seats per the Routine Maintenance Section. Lubricate the operator per the manufacturer's instructions.
	Ice is present in the yoke tube, handwheel unit, or operator.	Apply heat to melt ice.
	Line bind is present. (Pipeline bending moments distorting the valve body).	Relieve the bind or moment on the valve.
<b>(continued next page)</b>		



Trouble	Probable Cause	Remedy
(continued) Motor operator will not actuate valve.	(continued) Improperly sized motor operator.	(continued) Replace with properly sized motor operator.
	Improperly wired electric operator.	Verify wiring following instructions and schematics provided by the operator manufacturer.
Valve operation is erratic.	The bearings need lubrication.	Lubricate bearings per the Routine Maintenance Section.
	The bearing or gear unit is broken or damaged.	Replace broken or damaged parts.
The valve seats will not seal.	Valve is not fully closed.	Fully close the valve. Turn the handwheel CLOCKWISE. DO BACK OFF THE HANDWHEEL.
	Seat or seat seals are damaged.	Lubricate seats per Routine Maintenance Section. Replace parts.

<sup>1</sup>Contact local Cameron Valves & Measurement Representative for current part number

<sup>2</sup>Pressure locked is a condition that may exist in any double sealing gate valve when the body cavity pressure greatly exceeds line pressure. It occurs only in the full open or full closed position and indicates that the sealing surfaces are in good condition.







**VALVES & MEASUREMENT**  
**3250 Briarpark Drive, Suite 300**  
**Houston, TX 77042**  
**USA Toll 800 323 9160**

For the most current contact and location information go to: [www.c-a-m.com](http://www.c-a-m.com)