

## Applied Fluid Mechanics

1. The Nature of Fluid and the Study of Fluid Mechanics
2. Viscosity of Fluid
3. Pressure Measurement
4. Forces Due to Static Fluid
5. Buoyancy and Stability
6. Flow of Fluid and Bernoulli's Equation
7. General Energy Equation
8. Reynolds Number, Laminar Flow, Turbulent Flow and Energy Losses Due to Friction

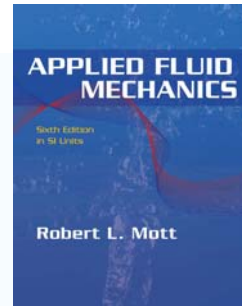

©2005 Pearson Education South Asia Pte Ltd

## Applied Fluid Mechanics

9. Velocity Profiles for Circular Sections and Flow in Noncircular Sections
10. Minor Losses
11. Series Pipeline Systems
12. Parallel Pipeline Systems
13. Pump Selection and Application
14. Open-Channel Flow
15. Flow Measurement
16. Forces Due to Fluids in Motion

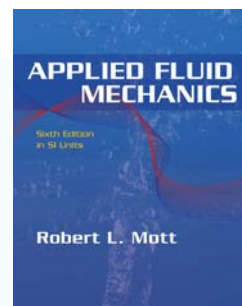

©2005 Pearson Education South Asia Pte Ltd

## Applied Fluid Mechanics

- 17. Drag and Lift
- 18. Fans, Blowers, Compressors and the Flow of Gases
- 19. Flow of Air in Ducts

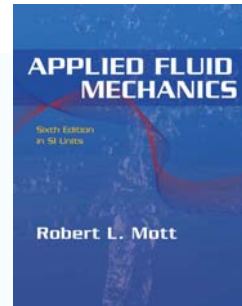

©2005 Pearson Education South Asia Pte Ltd

## 13. Pump Selection and Applications

### Chapter Objectives

- List the parameters involved in pump selection.
- List the types of information that must be specified for a given pump.
- Describe the basic pump classifications.
- List four types of rotary positive-displacement pumps.
- List three types of reciprocating positive-displacement pumps.
- List three types of kinetic pumps.
- Describe the main features of centrifugal pumps.
- Describe *deep-well jet pumps* and *shallow-well jet pumps*.

©2005 Pearson Education South Asia Pte Ltd

## 13. Pump Selection and Applications

### Chapter Objectives

- Describe the typical performance curve for rotary positive-displacement pumps.
- Describe the typical performance curve for centrifugal pumps.
- State the *affinity laws* for centrifugal pumps as they relate to the relationships among speed, impeller diameter, capacity, total head capability, and power required to drive the pump.
- Describe how the operating point of a pump is related to the system resistance curve.
- Define the *net positive suction head (NPSH)* for a pump and discuss its significance in pump performance.

©2005 Pearson Education South Asia Pte Ltd

## 13. Pump Selection and Applications

### Chapter Objectives

- Describe the importance of the vapor pressure of the fluid in relation to the *NPSH*.
- Compute the *NPSH* available for a given suction line design and a given fluid.
- Define the *specific speed* for a centrifugal pump and discuss its relationship to pump selection.
- Describe the effect of increased viscosity on the performance of centrifugal pumps.
- Describe the performance of parallel pumps and pumps connected in series.
- Describe the features of a desirable suction line design.

©2005 Pearson Education South Asia Pte Ltd

## 13. Pump Selection and Applications

### Chapter Objectives

- Describe the features of a desirable discharge line design.
- Describe the concept of life cycle cost applied to pump selection and operation of the fluid flow system.

©2005 Pearson Education South Asia Pte Ltd

## 13. Pump Selection and Applications

### Chapter Outline

1. Introductory Concepts
2. Parameters Involved In Pump Selection
3. Types of Pumps
4. Positive-Displacement Pumps
5. Kinetic Pumps
6. Performance Data For Centrifugal Pumps
7. Affinity Laws For Centrifugal Pumps
8. Manufacturers' Data For Centrifugal Pumps
9. The Operating Point of a Pump and Pump Selection

©2005 Pearson Education South Asia Pte Ltd

## 13. Pump Selection and Applications

### Chapter Outline

10. Net Positive Suction Head
11. Suction Line Details
12. Discharge Line Details
13. Piping System Design and Pump Selection Procedure
14. Alternate System Operating Modes
15. Pump Selection and Specific Speed
16. Life Cycle Costs for Pumped Fluid Systems
17. Software for Piping System Design and Pump Selection

©2005 Pearson Education South Asia Pte Ltd

## 13. Pump Selection and Applications

### 13.1 Introductory Concepts

- In Chapter 7, when the general energy equation was introduced you learned how to determine the energy added by a pump to the fluid as follow,

$$h_a = \frac{p_2 - p_1}{\gamma} + z_2 - z_1 + \frac{v_2^2 - v_1^2}{2g} + h_L \quad (13-1)$$

- We will call  $h_a$  the *total head on the pump*.
- Some pump manufacturers refer to this as the *total dynamic head (TDH)*.

©2005 Pearson Education South Asia Pte Ltd

## 13. Pump Selection and Applications

### 13.1 Introductory Concepts

- You also learned how to compute the power delivered to the fluid by the pump,

$$P_A = h_a \gamma Q \quad (13-2)$$

- You also learned in Chapter 7 to use the efficiency of the pump to determine the power input to the pump:

$$e_M = P_A / P_I \quad (13-3)$$

$$P_I = P_A / e_M \quad (13-4)$$

©2005 Pearson Education South Asia Pte Ltd

## 13. Pump Selection and Applications

### 13.2 Parameters Involved In Pump selection

- When selecting a pump for a particular application, the following factors must be considered:
  1. The nature of the liquid to be pumped
  2. The required capacity (volume flow rate)
  3. The conditions on the suction (inlet) side of the pump
  4. The conditions on the discharge (outlet) side of the pump
  5. The total head on the pump (the term from the energy equation)

©2005 Pearson Education South Asia Pte Ltd

## 13. Pump Selection and Applications

### 13.2 Parameters Involved In Pump selection

6. The type of system to which the pump is delivering the fluid
7. The type of power source (electric motor, diesel engine, steam turbine, etc.)
8. Space, weight, and position limitations
9. Environmental conditions
10. Cost of pump purchase and installation
11. Cost of pump operation
12. Governing codes and standards

©2005 Pearson Education South Asia Pte Ltd

## 13. Pump Selection and Applications

### 13.2 Parameters Involved In Pump selection

- After pump selection, the following items must be specified:
  1. Type of pump and manufacturer
  2. Size of pump
  3. Size of suction connection and type (flanged, screwed, etc.)
  4. Size and type of discharge connection
  5. Speed of operation

©2005 Pearson Education South Asia Pte Ltd

## 13. Pump Selection and Applications

### 13.2 Parameters Involved In Pump selection

6. Specifications for driver (for example: for an electric motor—power required, speed, voltage, phase, frequency, frame size, enclosure type)
7. Coupling type, manufacturer, and model number
8. Mounting details
9. Special materials and accessories required, if any
10. Shaft seal design and seal materials

©2005 Pearson Education South Asia Pte Ltd

## 13. Pump Selection and Applications

### 13.3 Types of Pumps

- Pumps are typically classified as either positive-displacement or kinetic pumps.
- Table 13.1 lists several kinds of each.

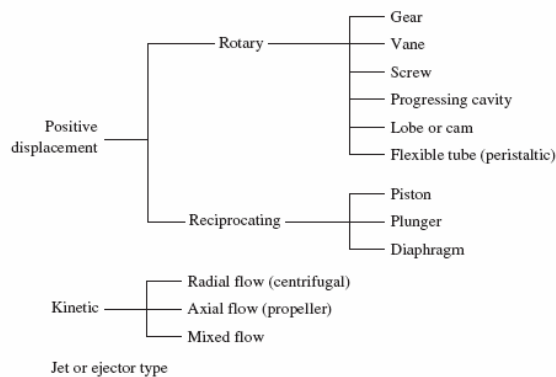

©2005 Pearson Education South Asia Pte Ltd



## 13. Pump Selection and Applications

### 13.4 Positive-Displacement Pumps

- Positive-displacement pumps ideally deliver a fixed quantity of fluid with each revolution of the pump rotor or drive shaft.
- Most positive-displacement pumps can handle liquids over a wide range of viscosities.
- Some of the examples are gear, piston, vane, screw, progressive cavity, lobe, piston, diaphragm and peristaltic pumps.

©2005 Pearson Education South Asia Pte Ltd

## 13. Pump Selection and Applications

### 13.4 Positive-Displacement Pumps

- Fig 13.1 shows a vane pump.

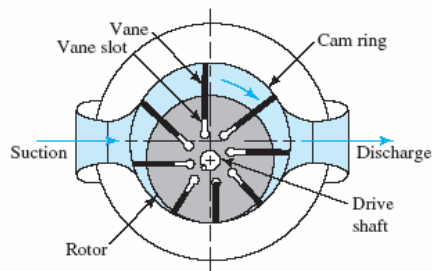

©2005 Pearson Education South Asia Pte Ltd

### 13. Pump Selection and Applications

#### 13.4 Positive-Displacement Pumps

- Fig 13.2 shows a screw pump.

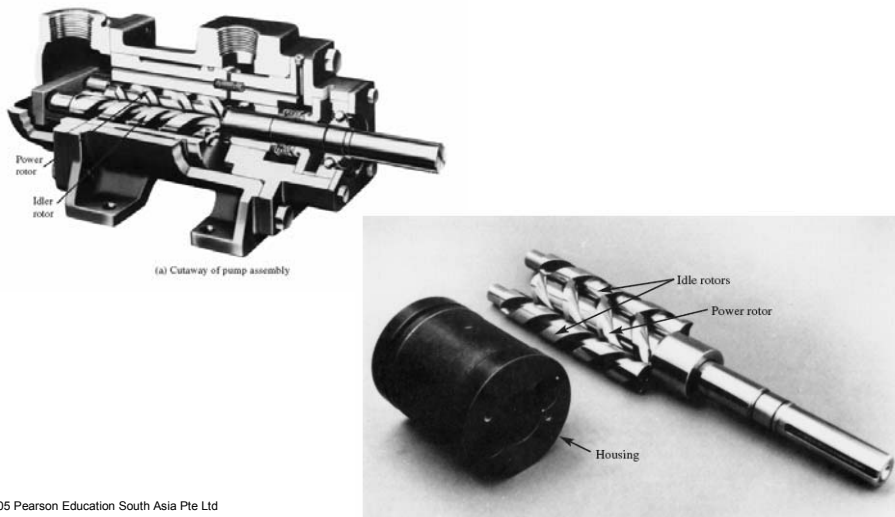

### 13. Pump Selection and Applications

#### 13.4 Positive-Displacement Pumps

- Fig 13.3 shows a progressing cavity pump.

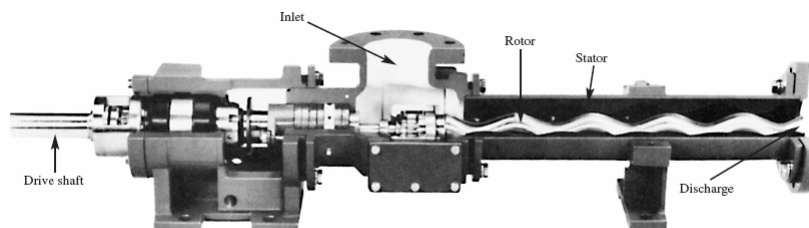

©2005 Pearson Education South Asia Pte Ltd

### 13. Pump Selection and Applications

#### 13.4 Positive-Displacement Pumps

- Fig 13.4 shows a progressing lobe pump.

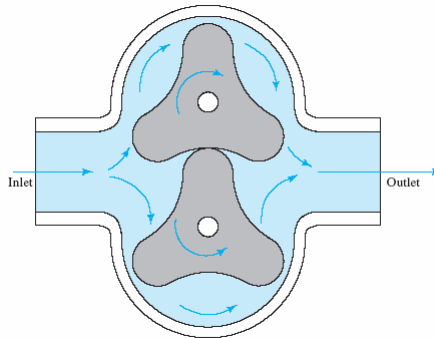

©2005 Pearson Education South Asia Pte Ltd

### 13. Pump Selection and Applications

#### 13.4 Positive-Displacement Pumps

- Fig 13.5 shows a piston pumps for fluid transfer.

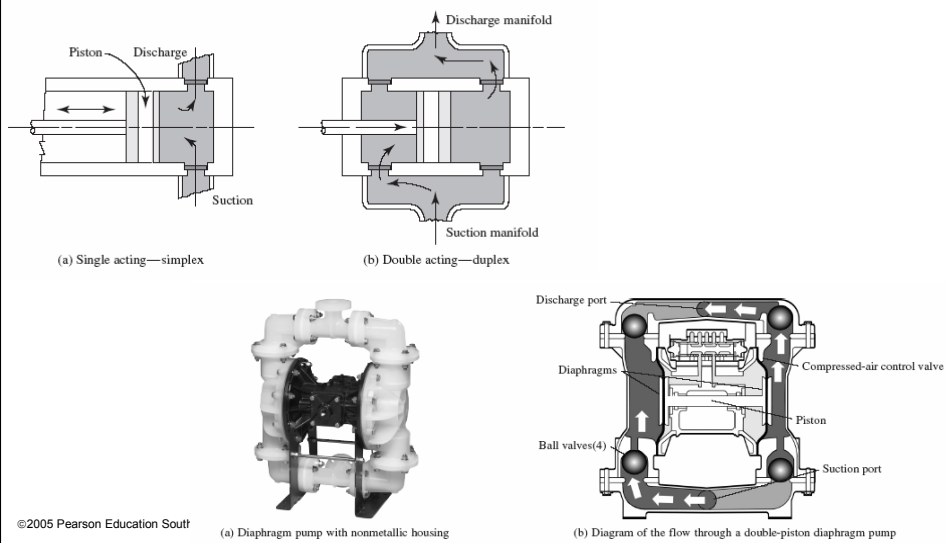

©2005 Pearson Education Sout

## 13. Pump Selection and Applications

### 13.4 Positive-Displacement Pumps

- Fig 13.6 shows a peristaltic pump.

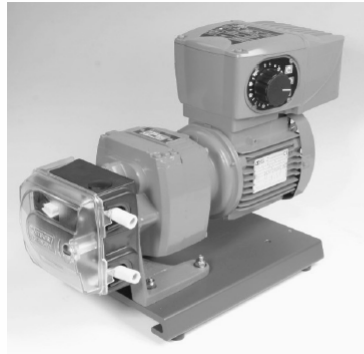

(a) Peristaltic pump with variable-speed drive system

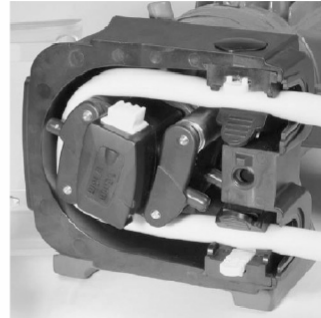

(b) Peristaltic pump with case open to show tubing and rotating drive rollers

©2005 Pearson Education South Asia Pte Ltd

## 13. Pump Selection and Applications

### 13.4.1 Performance Data for Positive-Displacement Pumps

- The operating characteristics of positive-displacement pumps make them useful for handling such fluids as water, hydraulic oils in fluid power systems.
- Some disadvantages of some designs include pulsating output, susceptibility to damage by solids and abrasives, and need for a relief valve.

©2005 Pearson Education South Asia Pte Ltd

## 13. Pump Selection and Applications

### 13.4.2 Reciprocating Pump Performance

- In its simplest form, the reciprocating pump (Fig. 13.5) employs a piston that draws fluid into a cylinder through an intake valve as the piston draws away from the valve.
- Then, as the piston moves forward, the intake valve closes and the fluid is pushed out through the discharge valve.
- Such a pump is called *simplex*, and its curve of discharge versus time looks like that shown in Fig. 13.8(a).

©2005 Pearson Education South Asia Pte Ltd

## 13. Pump Selection and Applications

### 13.4.2 Reciprocating Pump Performance

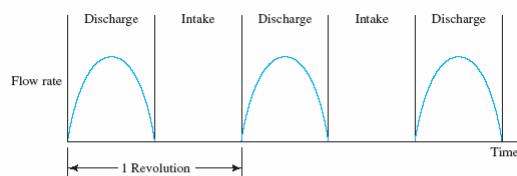

(a) Single-acting pump—simplex

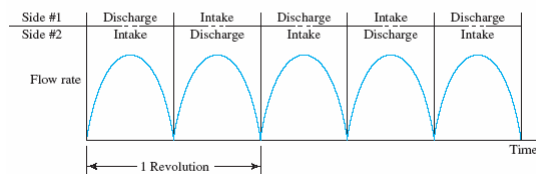

(b) Double-acting pump—duplex

©2005 Pearson Education South Asia Pte Ltd

## 13. Pump Selection and Applications

### 13.4.3 Rotary Pump Performance

- Figure 13.9 shows a typical set of performance curves for rotary pumps such as gear, vane, screw, and lobe pumps.
- It is a plot of capacity, efficiency, and power versus discharge pressure.
- As pressure is increased, a slight decrease in capacity occurs due to internal leakage from the high-pressure side to the low-pressure side.
- *Volumetric efficiency* is a measure of the ratio of the volume flow rate delivered by the pump to the theoretical delivery, based on the displacement per revolution of the pump, times the speed of rotation.

©2005 Pearson Education South Asia Pte Ltd

## 13. Pump Selection and Applications

### 13.4.3 Rotary Pump Performance

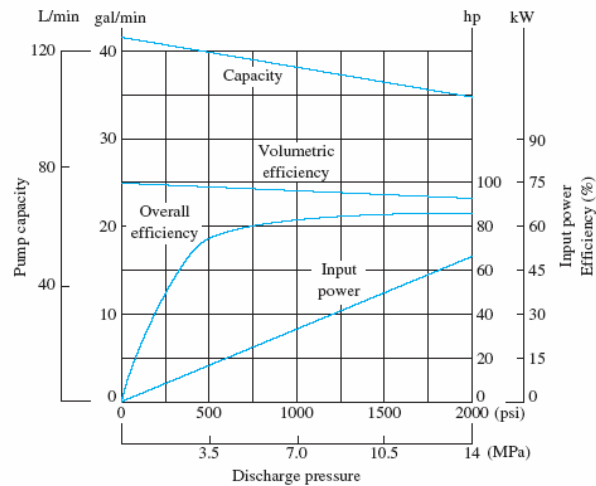

©2005 Pearson Education South Asia Pte Ltd

## 13. Pump Selection and Applications

### 13.5 Kinetic Pump

- *Kinetic pumps* add energy to the fluid by accelerating it through the action of a rotating *impeller*.
- Figure 13.10 shows the basic configuration of a radial flow centrifugal pump, the most common type of kinetic pump.
- Figure 13.11 shows the basic design of radial, axial, and mixed-flow impellers.
- The propeller type of pump (axial flow) depends on the hydrodynamic action of the propeller blades to lift and accelerate the fluid axially, along a path parallel to the axis of the propeller.

©2005 Pearson Education South Asia Pte Ltd

## 13. Pump Selection and Applications

### 13.5 Kinetic Pump

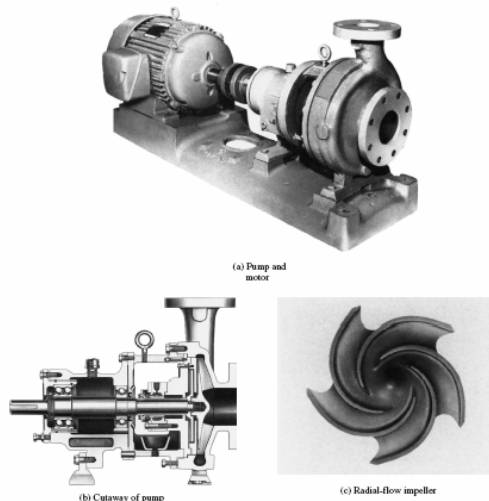

©2005 Pearson Education South Asia Pte Ltd

## 13. Pump Selection and Applications

### 13.5 Kinetic Pump

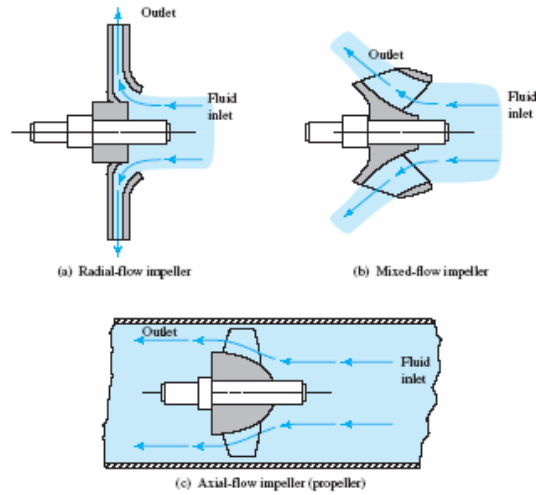

©2005 Pearson Education South Asia Pte Ltd

## 13. Pump Selection and Applications

### 13.5 Kinetic Pump

- Examples of kinetic pumps are:
  1. Jet Pumps
  2. Submersible Pumps
  3. Small Centrifugal Pumps
  4. Self-priming Pumps
  5. Vertical Turbine Pumps
  6. Centrifugal Grinder Pumps

©2005 Pearson Education South Asia Pte Ltd



## 13. Pump Selection and Applications

### 13.5 Kinetic Pump

- Fig 13.12 shows the deep-well jet pump.

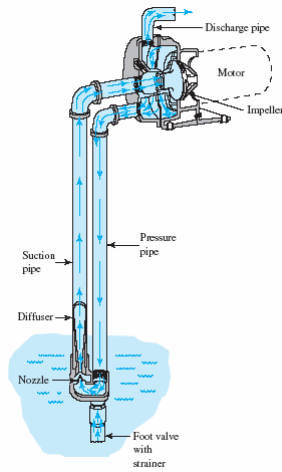

©2005 Pearson Education South Asia Pte Ltd

## 13. Pump Selection and Applications

### 13.5 Kinetic Pump

- Fig 13.13 shows the shallow-well jet pump.

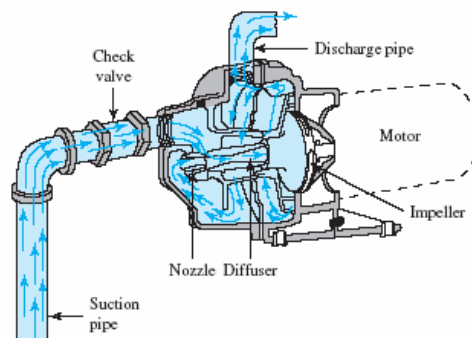

©2005 Pearson Education South Asia Pte Ltd

## 13. Pump Selection and Applications

### 13.5 Kinetic Pump

- Fig 13.13 shows the shallow-well jet pump.

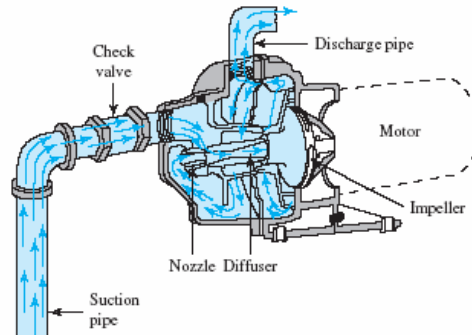

©2005 Pearson Education South Asia Pte Ltd

## 13. Pump Selection and Applications

### 13.5 Kinetic Pump

- Fig 13.14 shows the portable submersible pump.

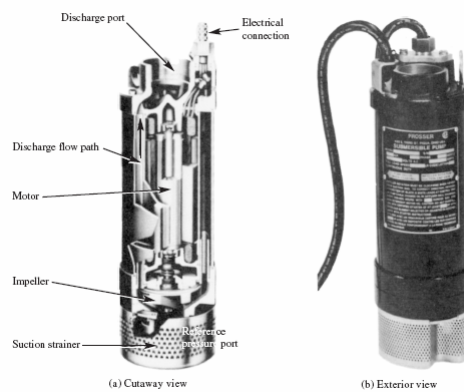

©2005 Pearson Education South Asia Pte Ltd

## 13. Pump Selection and Applications

### 13.5 Kinetic Pump

- Fig 13.15 shows the small centrifugal pump with integral motor.

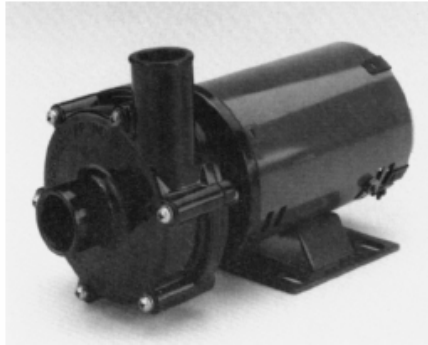

©2005 Pearson Education South Asia Pte Ltd

## 13. Pump Selection and Applications

### 13.5 Kinetic Pump

- Fig 13.16 shows the self-priming pump. (1) Suction inlet casing, (2) impeller, (3) mechanical shaft seal, (4) shaft.

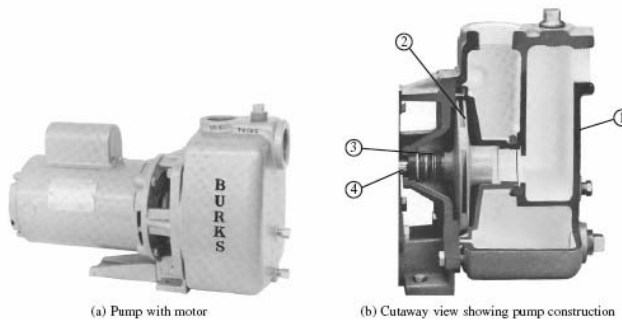

©2005 Pearson Education South Asia Pte Ltd

## 13. Pump Selection and Applications

### 13.5 Kinetic Pump

- Fig 13.17 shows the vertical turbine pump.

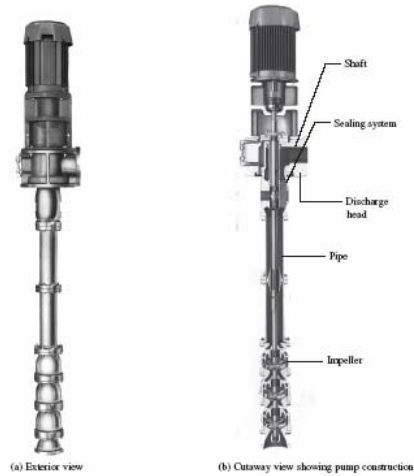

©2005 Pearson Education South Asia Pte Ltd

## 13. Pump Selection and Applications

### 13.5 Kinetic Pump

- Fig 13.18 shows the centrifugal grinder pump.

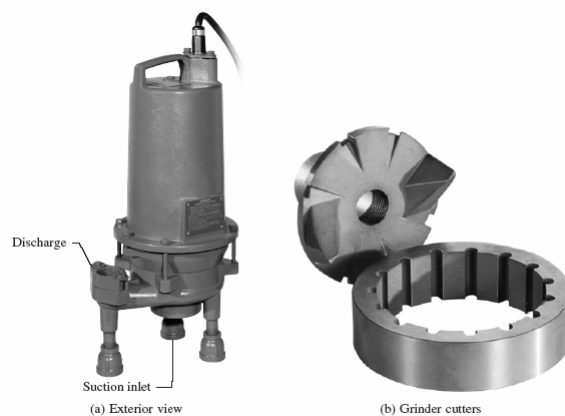

©2005 Pearson Education South Asia Pte Ltd

## 13. Pump Selection and Applications

### 13.6 Performance Data for Centrifugal Pumps

- Because centrifugal pumps are not positive-displacement types, there is a strong dependency between capacity and the pressure that must be developed by the pump.
- This makes their performance ratings somewhat more complex.
- The typical rating curve plots the total head on the pump versus the capacity or discharge  $Q$ , as shown in Fig. 13.19.

©2005 Pearson Education South Asia Pte Ltd

## 13. Pump Selection and Applications

### 13.6 Performance Data for Centrifugal Pumps

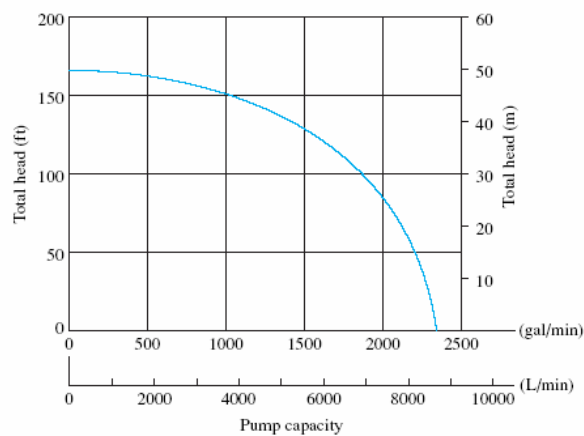

©2005 Pearson Education South Asia Pte Ltd

## 13. Pump Selection and Applications

### 13.6 Performance Data for Centrifugal Pumps

- Efficiency and power required are also important to the successful operation of a pump.
- Figure 13.20 shows a more complete performance rating of a pump, superimposing head, efficiency, and power curves and plotting all three versus capacity.

©2005 Pearson Education South Asia Pte Ltd

## 13. Pump Selection and Applications

### 13.6 Performance Data for Centrifugal Pumps

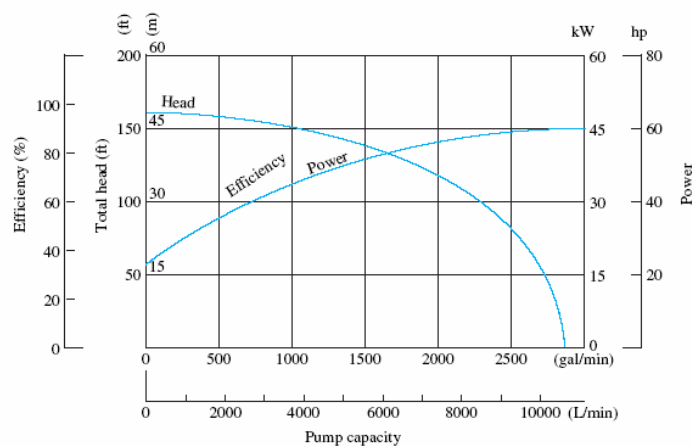

©2005 Pearson Education South Asia Pte Ltd

## 13. Pump Selection and Applications

### 13.7 Affinity Laws for Centrifugal Pumps

- It is important to understand the manner in which capacity, head, and power vary when either speed or impeller diameter is varied.
- These relationships, called *affinity laws*, are listed here.
- The symbol  $N$  refers to the rotational speed of the impeller, usually in revolutions per minute (r/min, or rpm).

©2005 Pearson Education South Asia Pte Ltd

## 13. Pump Selection and Applications

### 13.7 Affinity Laws for Centrifugal Pumps

- When *speed varies*:
  1. Capacity varies directly with speed:

$$\frac{Q_1}{Q_2} = \frac{N_1}{N_2} \quad (13-5)$$

2. The total head capability varies with the square of the speed:

$$\frac{h_{a1}}{h_{a2}} = \left(\frac{N_1}{N_2}\right)^2 \quad (13-6)$$

©2005 Pearson Education South Asia Pte Ltd

## 13. Pump Selection and Applications

### 13.7 Affinity Laws for Centrifugal Pumps

3. The power required by the pump varies with the cube of the speed:

$$\frac{P_1}{P_2} = \left(\frac{N_1}{N_2}\right)^3 \quad (13-7)$$

©2005 Pearson Education South Asia Pte Ltd

## 13. Pump Selection and Applications

### 13.7 Affinity Laws for Centrifugal Pumps

- When *impeller varies*:
1. Capacity varies directly with impeller diameter:

$$\frac{Q_1}{Q_2} = \frac{D_1}{D_2} \quad (13-8)$$

2. The total head varies with the square of the impeller diameter:

$$\frac{h_{a1}}{h_{a2}} = \left(\frac{D_1}{D_2}\right)^2 \quad (13-9)$$

©2005 Pearson Education South Asia Pte Ltd



## 13. Pump Selection and Applications

### 13.7 Affinity Laws for Centrifugal Pumps

3. The power required by the pump varies with the cube of the impeller diameter:

$$\frac{P_1}{P_2} = \left(\frac{D_1}{D_2}\right)^3 \quad (13-10)$$

- Efficiency remains nearly constant for speed changes and for small changes in impeller diameter.

©2005 Pearson Education South Asia Pte Ltd

## 13. Pump Selection and Applications

### Example 13.1

Assume that the pump for which the performance data are plotted in Fig. 13.20 was operating at a rotational speed of 1750 rpm and that the impeller diameter was 330 mm. First determine the head that would result in a capacity of 5670 L/min (1500 gal/min) and the power required to drive the pump. Then, compute the performance at a speed of 1250 rpm.

From Fig. 13.20, projecting upward from  $Q_1=5670$  L/min (1500 gal/min) gives

$$\begin{aligned} \text{Total head} &= 40 \text{ m} = h_{a1} \\ \text{Power required} &= 37 \text{ kW} = P_1 \end{aligned}$$

©2005 Pearson Education South Asia Pte Ltd

## 13. Pump Selection and Applications

### Example 13.1

When the speed is changed to 1250 rpm, the new performance can be computed by using the affinity laws:

$$\text{Capacity: } Q_2 = Q_1(N_2/N_1) = 5670(1250/1750) = 4050 \text{ L/min}$$

$$\text{Head: } h_{a2} = h_{a1}(N_2/N_1)^2 = 40(1250/1750)^2 = 20.4 \text{ m}$$

$$\text{Power: } P_2 = P_1(N_2/N_1)^3 = 37(1250/1750)^3 = 13.5 \text{ kW}$$

Note the significant decrease in the power required to run the pump. If the capacity and the available head are adequate, large savings in energy costs can be obtained by varying the speed of operation of a pump.

©2005 Pearson Education South Asia Pte Ltd

## 13. Pump Selection and Applications

### 13.8 Manufacturers' Data for Centrifugal Pumps

- Figure 13.21 shows a composite rating chart for one line of pumps, which allows the quick determination of the pump size.

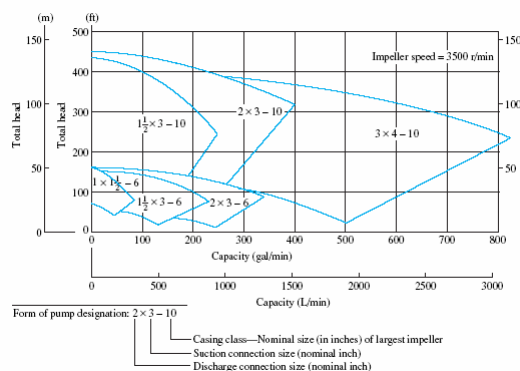

©2005 Pearson Education South Asia Pte Ltd

## 13. Pump Selection and Applications

### 13.8.1 Effect of Impeller Size

- Figure 13.22 shows how the performance of a given pump varies as the size of the impeller varies.

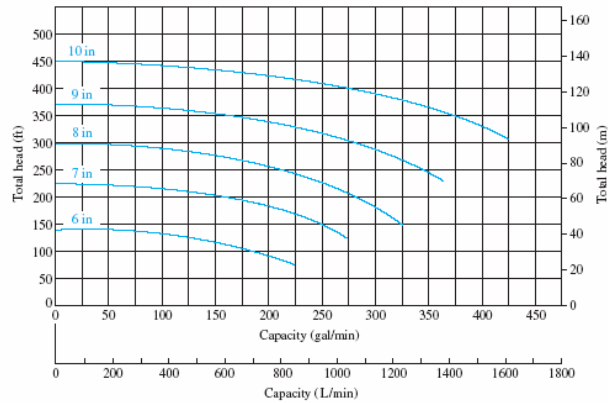

©2005 Pearson Education South Asia Pte Ltd

## 13. Pump Selection and Applications

### 13.8.2 Effect of Speed

- Figure 13.23 shows the performance of the same pump operating at 1750 rpm (a standard four-pole motor speed) instead of 3500 rpm.

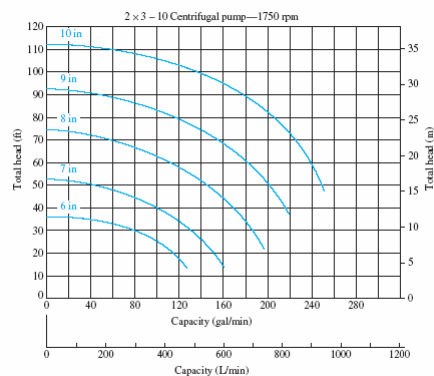

©2005 Pearson Education South Asia Pte Ltd.

## 13. Pump Selection and Applications

### 13.8.3 Power Required

- Figure 13.24 is the same as Fig. 13.22, except that the curves showing the power required to drive the pump have been added.

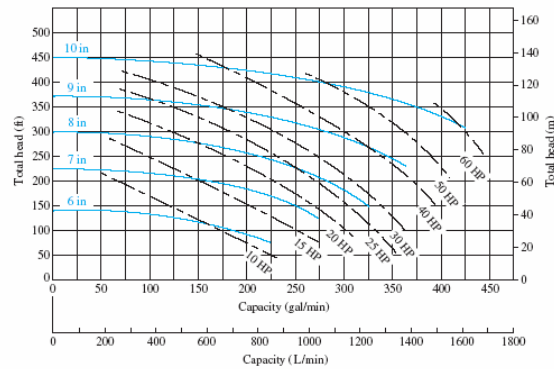

©2005 Pearson Education South Asia Pte Ltd

## 13. Pump Selection and Applications

### 13.8.4 Efficiency

- Figure 13.25 is the same as Fig. 13.22, except that curves of constant efficiency have been added.

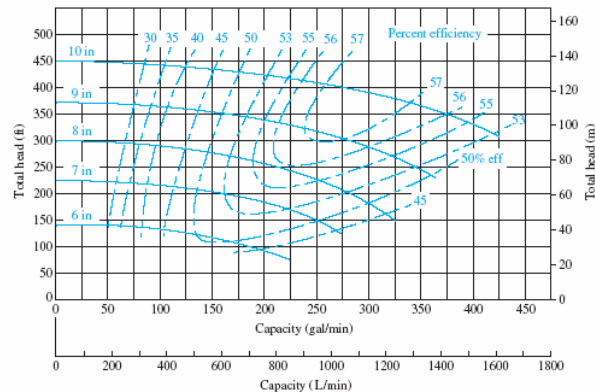

©2005 Pearson Education South Asia Pte Ltd

## 13. Pump Selection and Applications

### 13.8.5 Net Positive Suction Head Required

- Net positive suction head required (*NPSHR*) is an important factor to consider in applying a pump.
- *NPSHR* is related to the pressure at the inlet to the pump.
- Fig 13.26 shows the illustration of pump performance for different impeller diameters with net positive suction head required.

©2005 Pearson Education South Asia Pte Ltd

## 13. Pump Selection and Applications

### 13.8.5 Net Positive Suction Head Required

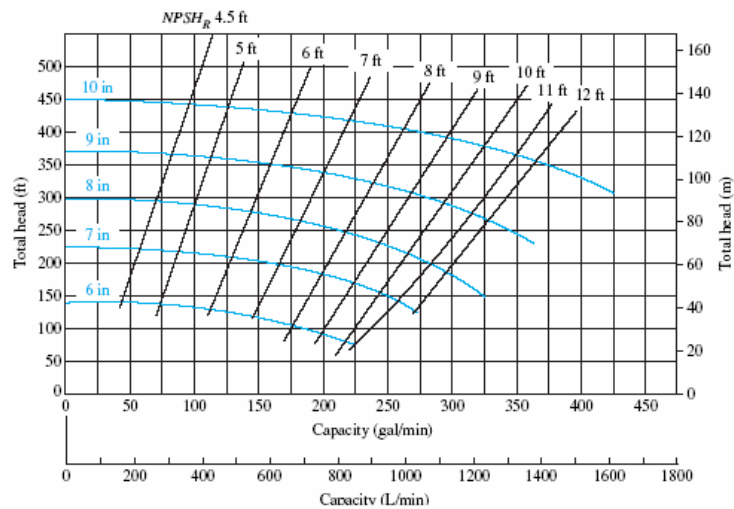

©2005 Pearson Education South Asia Pte Ltd

## 13. Pump Selection and Applications

### 13.8.6 Composite Performance Chart

- Figure 13.27 puts all these data together on one chart so the user can see all important parameters at the same time.

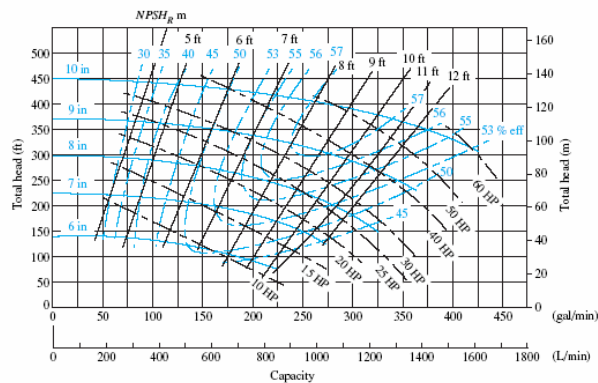

©2005 Pearson Education South Asia Pte Ltd

## 13. Pump Selection and Applications

### Example 13.2

A centrifugal pump must deliver at least 945 L/min of water at a total head of 91 m (300 ft) of water. Specify a suitable pump. List its performance characteristics.

©2005 Pearson Education South Asia Pte Ltd

## 13. Pump Selection and Applications

### Example 13.2

One possible solution can be found from Fig. 13.27. The pump with a 0.23 m (9-in) impeller will deliver approximately 1040 L/min (275 gal/min) at 91 m (300 ft) of head. At this operating point, the efficiency would be 57 percent, near the maximum for this type of pump. Approximately 28 kW (37 hp) would be required. The *NPSHR* at the suction inlet to the pump is approximately 2.8 m (9.2 ft) of water.

©2005 Pearson Education South Asia Pte Ltd

## 13. Pump Selection and Applications

### 13.8.7 Additional Performance Chart

- Figures 13.28–13.33 show the composite performance charts for six other medium-sized centrifugal pumps.
- Figures 13.34 and 13.35 show two additional performance curves for smaller centrifugal pumps.
- Because these pumps are generally offered with only one impeller size, the manner of displaying the performance parameters is somewhat different.

©2005 Pearson Education South Asia Pte Ltd

### 13. Pump Selection and Applications

#### 13.8.7 Additional Performance Chart

- Figure 13.28 shows the performance for a 1.5 x 3, 6 centrifugal pump at 1750 rpm.

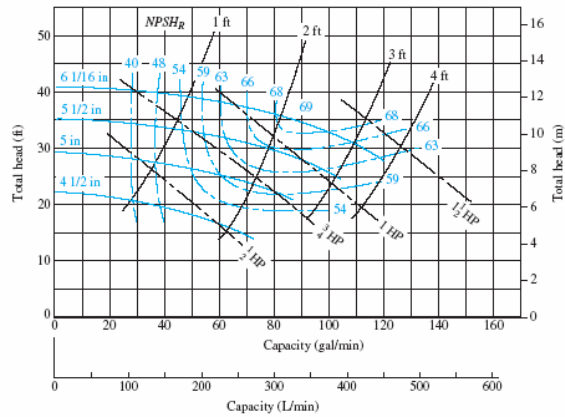

©2005 Pearson Education South Asia Pte Ltd

### 13. Pump Selection and Applications

#### 13.8.7 Additional Performance Chart

- Figure 13.29 shows the performance for a 3 x 4, 10 centrifugal pump at 1750 rpm.

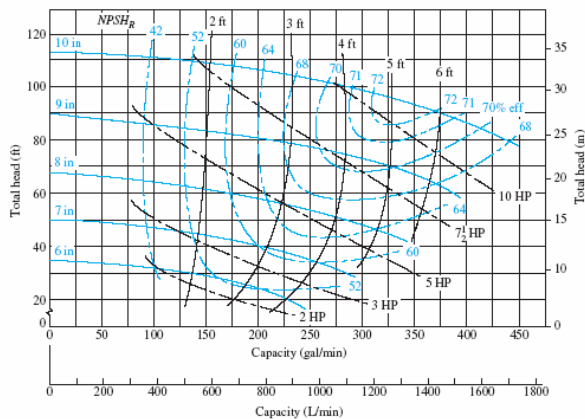

©2005 Pearson Education South Asia Pte Ltd



### 13. Pump Selection and Applications

#### 13.8.7 Additional Performance Chart

- Figure 13.30 shows the performance for a 3 x 4, 13 centrifugal pump at 1750 rpm.

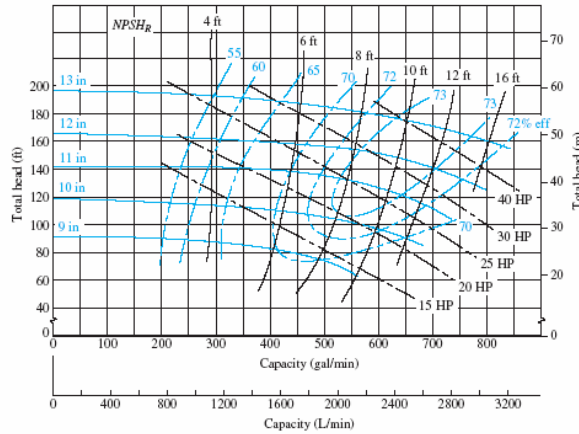

©2005 Pearson Education South Asia Pte Ltd

### 13. Pump Selection and Applications

#### 13.8.7 Additional Performance Chart

- Figure 13.31 shows the performance for a 6 x 8, 17 centrifugal pump at 1780 rpm.

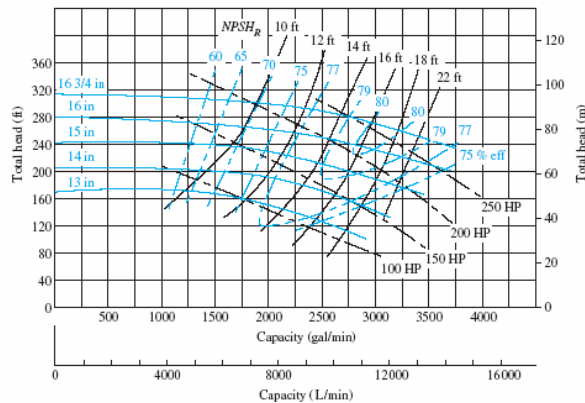

©2005 Pearson Education South Asia Pte Ltd

### 13. Pump Selection and Applications

#### 13.8.7 Additional Performance Chart

- Figure 13.32 shows the performance for a 2 x 3, 8 centrifugal pump at 3560 rpm.

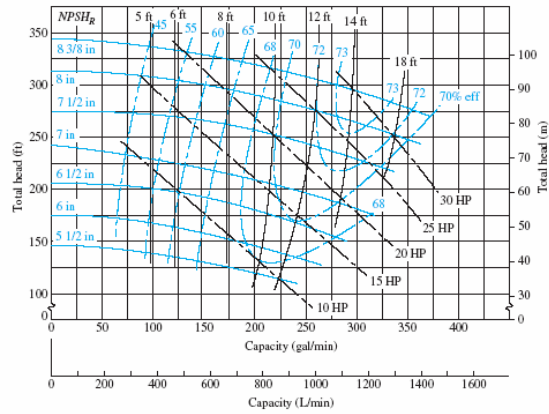

©2005 Pearson Education South Asia Pte Ltd

### 13. Pump Selection and Applications

#### 13.8.7 Additional Performance Chart

- Figure 13.33 shows the performance for a 1.5 x 3, 13 centrifugal pump at 3560 rpm.

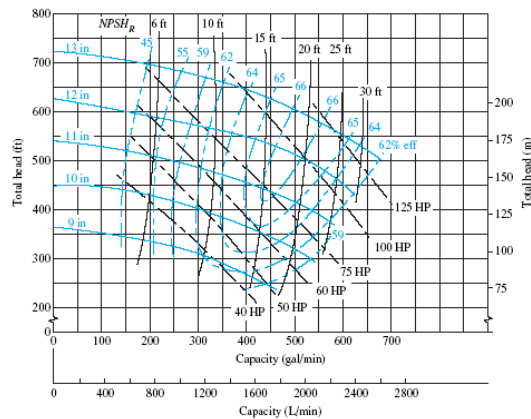

©2005 Pearson Education South Asia Pte Ltd

## 13. Pump Selection and Applications

### 13.8.7 Additional Performance Chart

- Figure 13.34 shows the Model TE-5.5 centrifugal pump.

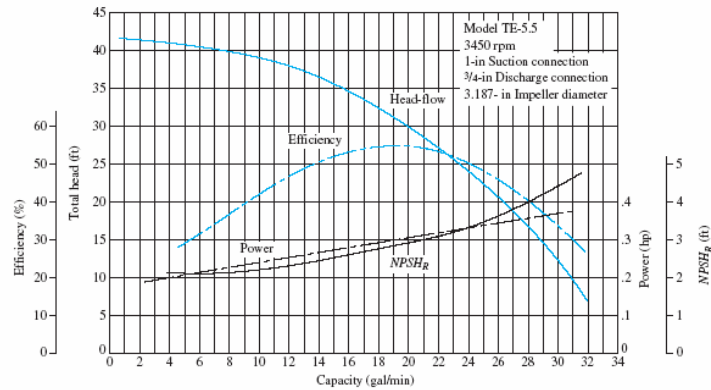

©2005 Pearson Education South Asia Pte Ltd

## 13. Pump Selection and Applications

### 13.9 The Operating Point of a Pump and Pump Selection

- The operating point of a pump is defined as the volume flow rate it will deliver when installed in a given system.
- The total head developed by the pump is determined by the system resistance corresponding to the same volume flow rate.
- Figure 13.36 illustrates the concept.

©2005 Pearson Education South Asia Pte Ltd

## 13. Pump Selection and Applications

### 13.9 The Operating Point of a Pump and Pump Selection

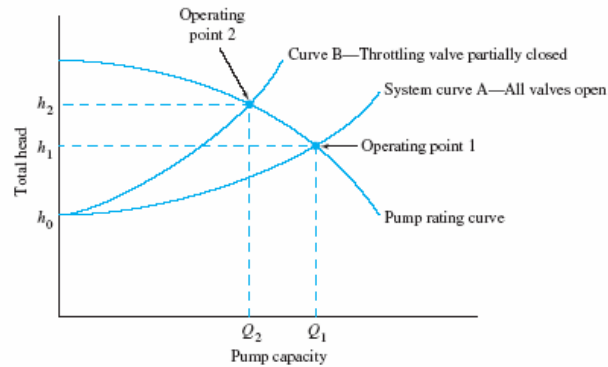

©2005 Pearson Education South Asia Pte Ltd

## 13. Pump Selection and Applications

### 13.9 The Operating Point of a Pump and Pump Selection

- The pump is holding the fluid at the elevation of the destination point in the system and maintaining the fluid pressure at that point.
- This point is called the *total static head*, where

$$h_0 = (p_2 - p_1)/\gamma + (z_2 - z_1) \quad (13-11)$$

- This equation, derived from the energy equation, says that the pump must develop a head equal to the pressure head difference between the two reference points plus the elevation head difference before any flow is delivered.

©2005 Pearson Education South Asia Pte Ltd

## 13. Pump Selection and Applications

### 13.9 The Operating Point of a Pump and Pump Selection

- As the flow increases with its corresponding increase in total head, the system curve eventually intersects the pump rating curve.
- ***Where the system curve and the pump rating curve intersect is the true operating point of the pump in this system.***

©2005 Pearson Education South Asia Pte Ltd

## 13. Pump Selection and Applications

### 13.10 Net Positive Suction Head

- An important part of the pump selection process is to ensure that the condition of the fluid entering the pump is suitable to maintain full liquid flow.
- The primary factor is the fluid pressure at the pump inlet, typically called the suction port.
- The design of the suction piping system must provide a sufficiently high pressure that will avoid the development of vapor bubbles within the flowing fluid, a condition called *cavitation*.

©2005 Pearson Education South Asia Pte Ltd

## 13. Pump Selection and Applications

### 13.10.1 Cavitations

- At the suction inlet of a pump, if the pump must pull fluid from below or if there are excessive energy losses in the suction line, the pressure at the pump may be sufficiently low to cause vapor bubbles to form in the fluid.
- When cavitation occurs, the performance of the pump is severely degraded as the volume flow rate delivered drops.
- The pump becomes noisy, giving off a loud, rattling sound as if gravel was flowing with the fluid. If this was allowed to continue, the pump would be destroyed in a short time.

©2005 Pearson Education South Asia Pte Ltd

## 13. Pump Selection and Applications

### 13.10.2 Vapor Pressure

- The fluid property that determines the conditions under which vapor bubbles form in a fluid is its *vapor pressure*  $p_{vp}$  typically reported as an absolute pressure in the units of kPa absolute or psia.
- The pressure of the liquid at this condition is called the vapor pressure.
- A liquid is called *volatile* if it has a relatively high vapor pressure and vaporizes rapidly at ambient conditions.
- Table 13.2 shows the vapor pressure and vapor pressure head of water.

©2005 Pearson Education South Asia Pte Ltd

## 13. Pump Selection and Applications

### 13.10.2 Vapor Pressure

| Temperature<br>°C | Vapor<br>Pressure<br>kPa (abs) | Specific<br>Weight<br>(kN/m <sup>3</sup> ) | Vapor<br>Pressure<br>Head (m) | Temperature<br>°F | Vapor<br>Pressure<br>(psia) | Specific<br>Weight<br>(lb/ft <sup>3</sup> ) | Vapor<br>Pressure<br>Head (ft) |
|-------------------|--------------------------------|--|-------------------------------|-------------------|-----------------------------|---|--------------------------------|
| 0                 | 0.6105                         | 9.806                                      | 0.06226                       | 32                | 0.08854                     | 62.42                                       | 0.2043                         |
| 5                 | 0.8722                         | 9.807                                      | 0.08894                       | 40                | 0.1217                      | 62.43                                       | 0.2807                         |
| 10                | 1.228                          | 9.804                                      | 0.1253                        | 50                | 0.1781                      | 62.41                                       | 0.4109                         |
| 20                | 2.338                          | 9.789                                      | 0.2388                        | 60                | 0.2563                      | 62.37                                       | 0.5917                         |
| 30                | 4.243                          | 9.765                                      | 0.4345                        | 70                | 0.3631                      | 62.30                                       | 0.8393                         |
| 40                | 7.376                          | 9.731                                      | 0.7580                        | 80                | 0.5069                      | 62.22                                       | 1.173                          |
| 50                | 12.33                          | 9.690                                      | 1.272                         | 90                | 0.6979                      | 62.11                                       | 1.618                          |
| 60                | 19.92                          | 9.642                                      | 2.066                         | 100               | 0.9493                      | 62.00                                       | 2.205                          |
| 70                | 31.16                          | 9.589                                      | 3.250                         | 120               | 1.692                       | 61.71                                       | 3.948                          |
| 80                | 47.34                          | 9.530                                      | 4.967                         | 140               | 2.888                       | 61.38                                       | 6.775                          |
| 90                | 70.10                          | 9.467                                      | 7.405                         | 160               | 4.736                       | 61.00                                       | 11.18                          |
| 100               | 101.3                          | 9.399                                      | 10.78                         | 180               | 7.507                       | 61.58                                       | 17.55                          |
|                   |                                |  |                               | 200               | 11.52                       | 60.12                                       | 27.59                          |
|                   |                                |  |                               | 212               | 14.69                       | 59.83                                       | 35.36                          |

©2005 Pearson Education South Asia Pte Ltd

## 13. Pump Selection and Applications

### 13.10.3 NPSH

- Pump manufacturers test each pump design to determine the level of suction pressure required to avoid cavitation, reporting the result as the *net positive suction head required*,  $NPSH_R$ , for the pump at each operating condition of capacity (volume flow rate) and total head on the pump.
- We can define the *NPSH margin*  $M$  to be

$$M = NPSH_A - NPSH_R \quad (13-12)$$

©2005 Pearson Education South Asia Pte Ltd

## 13. Pump Selection and Applications

### 13.10.3 NPSH

- In design problems in this book, we call for a minimum of 10% margin. That

$$NPSH_A > 1.10 NPSH_R \quad (13-13)$$

- Fig 13.37 shows the vapor pressure versus temperature for common liquids. The data for gasoline are approximate because there are many different formulations that have widely varying volatility for vehicle operation in different climates and altitudes.

©2005 Pearson Education South Asia Pte Ltd

## 13. Pump Selection and Applications

### 13.10.3 NPSH

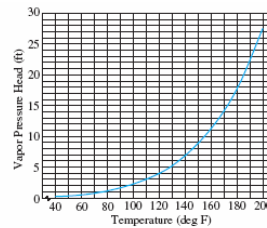
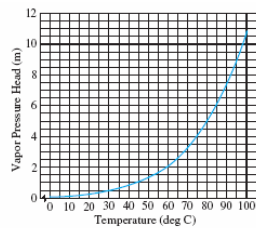

(a) Water

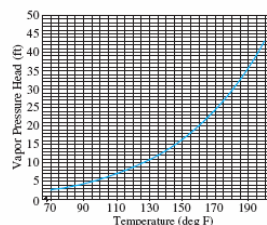
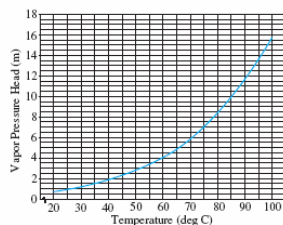

(b) Carbon Tetrachloride

©2005 Pearson Education South Asia Pte Ltd



## 13. Pump Selection and Applications

### 13.10.3 NPSH

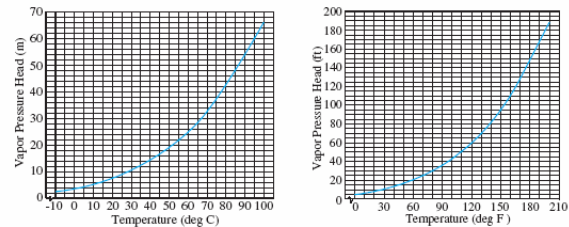

(c) Gasoline\*

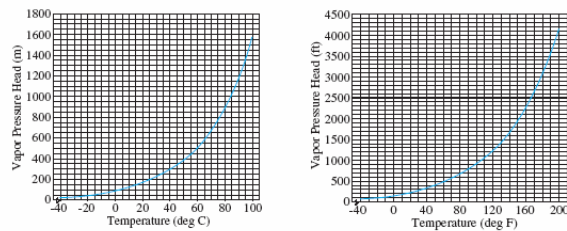

(d) Propane

©2005 Pearson Education South Asia Pte Ltd

## 13. Pump Selection and Applications

### 13.10.4 Computing $NPSH_A$

- The value of  $NPSH_A$  is dependent on the vapor pressure of the fluid being pumped, energy losses in the suction piping, the location of the fluid reservoir, and the pressure applied to the fluid in the reservoir.

- This can be expressed as

$$NPSH_A = h_{sp} \pm h_s - h_f - h_{vp} \quad (13-14)$$

- Fig 13.38 shows the pump suction-line details and definitions of terms for computing  $NPSH$ .

©2005 Pearson Education South Asia Pte Ltd

## 13. Pump Selection and Applications

### 13.10.4 Computing $NPSH_A$

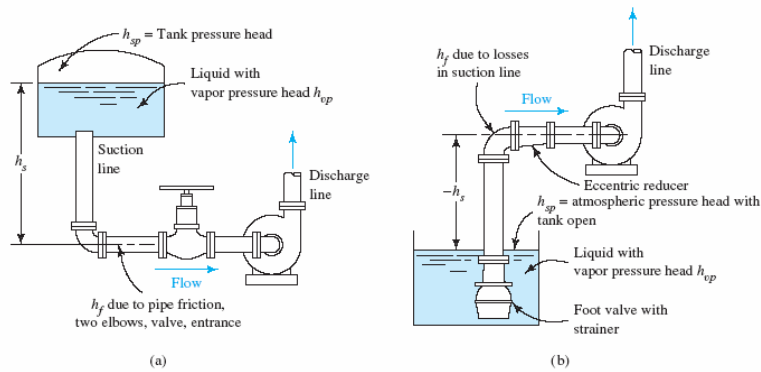

©2005 Pearson Education South Asia Pte Ltd

## 13. Pump Selection and Applications

### 13.10.4 Computing $NPSH_A$

- Figure 13.38(a) includes a pressurized reservoir placed above the pump.
- Part (b) shows the pump drawing fluid from an open reservoir below the pump.

$p_{sp}$  = Static pressure (absolute) above the fluid in the reservoir

$h_{sp}$  = Static pressure head (absolute) above the fluid in the reservoir, expressed in meters or feet of the liquid;  $h_{sp} = p_{sp}/\gamma$

$h_s$  = Elevation difference from the level of fluid in the reservoir to the centerline of the pump suction inlet, expressed in meters or feet

*If the pump is below the reservoir,  $h_s$  is positive [preferred; Fig. 13.38(a)]*

*If the pump is above the reservoir,  $h_s$  is negative [Fig. 13.38(b)]*

$h_f$  = Head loss in the suction piping due to friction and minor losses, expressed in meters or feet

$p_{vp}$  = Vapor pressure (absolute) of the liquid at the pumping temperature

$h_{vp}$  = Vapor pressure head of the liquid at the pumping temperature, expressed in meters or feet of the liquid;  $h_{vp} = p_{vp}/\gamma$

©2C

## 13. Pump Selection and Applications

### 13.10.5 Effect of Pump Speed on NPSH

- The data given in pump catalogs for *NPSH* are for water and apply only to the listed operating speed. If the pump is operated at a different speed, the *NPSH* required at the new speed can be calculated from

$$(NPSH_R)_2 = \left(\frac{N_2}{N_1}\right)^2 (NPSH_R)_1 \quad (13-15)$$

where the subscript 1 refers to catalog data and the subscript 2 refers to conditions at the new operating speed. The pump speed in rpm is *N*.

©2005 Pearson Education South Asia Pte Ltd

## 13. Pump Selection and Applications

### Example 13.3

Determine the available *NPSH* for the system shown in Fig. 13.38(a). The fluid reservoir is a closed tank with a pressure of -20 kPa above water at 70°C. The atmospheric pressure is 100.5 kPa. The water level in the tank is 2.5 m above the pump inlet. The pipe is a 1.5-in Schedule 40 steel pipe with a total length of 12.0 m. The elbow is standard and the valve is a fully open globe valve. The flow rate is 95 L/min.

©2005 Pearson Education South Asia Pte Ltd

## 13. Pump Selection and Applications

### Example 13.3

Using Eq. (13–14),

$$\begin{aligned}\text{Absolute pressure} &= \text{Atmospheric pressure} + \text{Tank gage pressure} \\ p_{\text{abs}} &= 100.5 \text{ kPa} - 20 \text{ kPa} = 80.5 \text{ kPa}\end{aligned}$$

But we know that

$$\begin{aligned}h_{sp} &= p_{\text{abs}}/\gamma \\ &= \frac{80.5 \times 10^3 \text{ N/m}^2}{9.59 \times 10^3 \text{ N/m}^3} = 8.39 \text{ m}\end{aligned}$$

Now, based on the elevation of the tank, we have

$$h_s = +2.5 \text{ m}$$

©2005 Pearson Education South Asia Pte Ltd

## 13. Pump Selection and Applications

### Example 13.3

To find the friction loss, we must find the velocity, Reynolds number, and friction factor:

$$\begin{aligned}v &= \frac{Q}{A} = \frac{95 \text{ L/min}}{1.314 \times 10^{-3} \text{ m}^2} \times \frac{1.0 \text{ m}^3/\text{s}}{60\,000 \text{ L/min}} = 1.21 \text{ m/s} \\ N_R &= \frac{vD}{\nu} = \frac{(1.21)(0.0409)}{4.11 \times 10^{-7}} = 1.20 \times 10^5 \quad (\text{turbulent}) \\ \frac{D}{\epsilon} &= \frac{0.0409 \text{ m}}{4.6 \times 10^{-5} \text{ m}} = 889\end{aligned}$$

Thus, from Fig. 8.6,  $f = 0.0225$ . From Table 10.5,  $f_T = 0.021$ . Now we have

$$h_f = \underbrace{f(L/D)(v^2/2g)}_{\text{(pipe)}} + \underbrace{2f_T(30)(v^2/2g)}_{\text{(elbows)}} + \underbrace{f_T(340)(v^2/2g)}_{\text{(valve)}} + \underbrace{1.0(v^2/2g)}_{\text{(entrance)}}$$

©2005 Pearson Education South Asia Pte Ltd

## 13. Pump Selection and Applications

### Example 13.3

The velocity head is

$$\frac{v^2}{2g} = \frac{(1.21 \text{ m/s})^2}{2(9.81 \text{ m/s}^2)} = 0.0746 \text{ m}$$

Then, the friction loss is

$$\begin{aligned} h_f &= (0.0225)(12/0.0409)(0.0746) + (0.021)(60)(0.0746) \\ &\quad + (0.021)(340)(0.0746) + 0.0746 \\ &= (0.0746 \text{ m})[(0.0225)(12/0.0409) + (0.021)(60) + (0.021)(340) + 1.0] \\ &= 1.19 \text{ m} \end{aligned}$$

Finally, from Table 13.2 we get

$$h_{vp} = 3.25 \text{ m at } 70^\circ\text{C}$$

©2005 Pearson Education South Asia Pte Ltd

## 13. Pump Selection and Applications

### Example 13.3

Combining these terms gives

$$NPSH_A = 8.39 \text{ m} + 2.5 \text{ m} - 1.19 \text{ m} - 3.25 \text{ m} = 6.45 \text{ m}$$

We can compute the maximum allowable  $NPSH_R$  for the pump from Eq. (13–13),

$$NPSH_A > 1.10 NPSH_R$$

$$NPSH_R < NPSH_A/1.10$$

Thus

$$NPSH_R < 6.45 \text{ m}/1.10 = 5.86 \text{ m}$$

©2005 Pearson Education South Asia Pte Ltd

## 13. Pump Selection and Applications

### 13.11 Suction Line Details

- The *suction line* refers to all parts of the flow system from the source of the fluid to the inlet of the pump.
- Figure 13.38 shows two methods of providing fluid to a pump. In part (a), a positive head is created by placing the pump below the supply reservoir.
- This is an aid in ensuring a satisfactory *NPSH*. In addition, the pump will always be primed with a column of liquid at start-up.
- In Fig. 13.38(b), a *suction lift* condition occurs because the pump must draw liquid from below.

©2005 Pearson Education South Asia Pte Ltd

## 13. Pump Selection and Applications

### 13.11 Suction Line Details

- Some of these practical considerations include the cost of pipe, valves, and fittings; the physical space available to accommodate these elements; and the attachment of the suction pipe to the suction connection of the pump.

©2005 Pearson Education South Asia Pte Ltd

## 13. Pump Selection and Applications

### 13.12 Discharge Line Details

- In general, the discharge line should be as short and direct as possible to minimize the head on the pump.
- Elbows should be of the standard or long-radius type if possible.
- Pipe size should be chosen according to velocity or allowable friction losses.
- As shown in Fig. 13.39, other elements may be added to the discharge line as required.
- A pressure relief valve will protect the pump and other equipment in case of a blockage of the flow or accidental shut-off of a valve.

©2005 Pearson Education South Asia Pte Ltd

## 13. Pump Selection and Applications

### 13.13 Piping System Design and Pump Selection

- Below are the piping system design procedure:
  1. Obtain specifications for the system including the fluid to be pumped, design value of the volume flow rate required, location of the fluid source reservoir, location of the destination point, and any prescribed elevations and pressures, particularly at the source and the destination.
  2. Determine the fluid properties including temperature, specific weight, kinematic viscosity, and vapor pressure.
  3. Generate a proposed piping layout including the place where fluid will be drawn from the source reservoir, the placement of the pump, and suction and discharge line details with appropriate valves, fittings, and special accessories or equipment. Consider connections to reservoirs, needs to shut off or control fluid flow rate, prevention of undesirable back flow, and service of the pump and other equipment in the system.

©2005 Pearson Education South Asia Pte Ltd

## 13. Pump Selection and Applications

### 13.13 Piping System Design and Pump Selection

4. Determine the lengths of pipe in the suction and discharge lines.
5. Specify the pipe sizes for the suction and discharge lines using Section 6.5 and Fig. 6.2 in Chapter 6 as a guide.
6. Analyze the system performance at the design flow rate to determine the total dynamic head using Eq. (13–1). The spreadsheet described in Section 11.4 can be used.
7. Evaluate the total static head from Eq. (13–11).

©2005 Pearson Education South Asia Pte Ltd

## 13. Pump Selection and Applications

### 13.13 Piping System Design and Pump Selection

8. Select a suitable pump that can deliver at least the design flow rate against the total dynamic head at that flow rate, considering the following:
  - a) Use Figs. 13.27–13.35, Internet sources, vendor catalogs, or software such as PumpBase supplied with this book.
  - b) Seek a pump with high efficiency at the design point and one for which the operating point is near the *best efficiency point (BEP)* for the pump.
  - c) Standards set jointly by the American National Standards Institute (ANSI) and the Hydraulic Institute (HI) call for a *preferred operating region (POR)* for centrifugal pumps to be between 70 percent and 120 percent of the *BEP*. See Standard ANSI/HI 9.6.3-1997, *Standard for Centrifugal and Vertical Pumps for Allowable Operating Region*.
  - d) Specify the model designation, speed, impeller size, and the sizes for the suction and discharge ports.

©2005 Pearson Education South Asia Pte Ltd



## 13. Pump Selection and Applications

### 13.13 Piping System Design and Pump Selection

9. Determine points on the system curve by analyzing the total head corresponding to a range of flow rates. The spreadsheet described in Section 11.4 can greatly facilitate this process because all system data were entered in Step 6. Only the flow rate needs to be changed for each calculation.
10. Plot the system curve on the pump performance graph and determine the actual expected operating point as the intersection of the pump head versus flow curve and the system curve.
11. At the actual operating point, determine the power required, the actual volume flow rate delivered, efficiency, and the *NPSH* required,  $NPSH_R$ . Also check the type of pump, mounting requirements, and types and sizes for the suction and discharge ports.

©2005 Pearson Education South Asia Pte Ltd

## 13. Pump Selection and Applications

### 13.13 Piping System Design and Pump Selection

12. Compute the *NPSH* available,  $NPSH_A$  for the system, using Eq. (13–14).
13. Ensure that  $NPSH_A > 1.10NPSH_R$  for all expected operating conditions.
14. If necessary, provide a means of connecting the specified pipe sizes to the connections for the pump if they are different sizes. See Fig. 7.1 for an example. Use a gradual reducer or a gradual expander to minimize energy losses added to the system by these elements.

©2005 Pearson Education South Asia Pte Ltd

## 13. Pump Selection and Applications

### Example 13.4

Figure 13.40 shows a system in which a pump is required to deliver at least 850 L/min of water at 15°C from a lower reservoir to an elevated tank maintained at a pressure of 240 kPa gage. Design the system and specify a suitable pump. Then determine the operating point for the pump in the system you have designed and give the performance parameters for the pump at the operating point.

©2005 Pearson Education South Asia Pte Ltd

## 13. Pump Selection and Applications

### Example 13.4

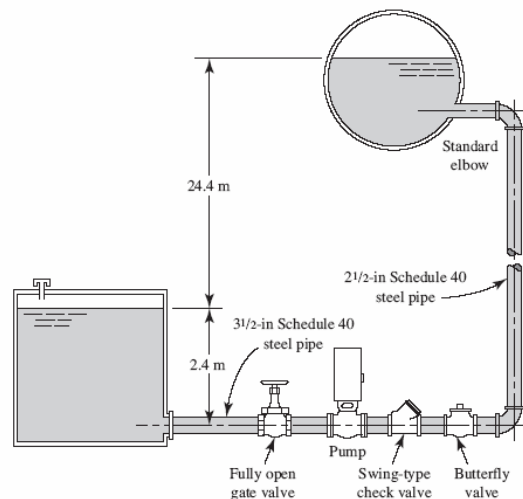

©2005 Pearson Education South Asia Pte Ltd

## 13. Pump Selection and Applications

### Example 13.4

Here we follow the steps listed in the Piping System Design Procedure.

**Step 1.** Fluid: Water at 15°C:

$Q=850$  L/min minimum

Source: lower reservoir;  $p = 0$  kPa

Elevation= $2.4$  m above pump inlet

Destination: upper reservoir;  $p=240$  kPa

Elevation= $26.8$  m above pump inlet

©2005 Pearson Education South Asia Pte Ltd

## 13. Pump Selection and Applications

### Example 13.4

**Step 2.** Water at 15°C:

$\gamma=9.80$  kN/m<sup>3</sup>;  $\nu = 1.12 \times 10^{-6}$  m<sup>2</sup>/s;  $h_{vp} = 0.182$  m.

**Step 3.** Figure 13.40 shows the proposed layout.

**Step 4.** Design decisions: Suction line is  $2.4$  m long; discharge line is  $110$  m.

**Step 5.** Using Fig. 6.2 as a guide:

Suction pipe is 3.5-in Schedule 40 steel pipe;  $D=0.09$  m,  $A=6.381 \times 10^{-3}$  m<sup>2</sup>

Discharge line is 2.5-in Schedule 40 steel pipe;  $D=0.063$  m,  $A=3.09 \times 10^{-3}$  m<sup>2</sup>

©2005 Pearson Education South Asia Pte Ltd

### 13. Pump Selection and Applications

#### Example 13.4

**Step 6.** Use the spreadsheet shown in Fig. 13.41. Reference point 1 is the surface of the lower reservoir. Reference point 2 is the surface of the upper reservoir. Other data are entered into the spreadsheet as discussed in Chapter 11. The result for the total dynamic head is given by

$$h_a = (z_2 - z_1) + p_2/\gamma + h_L = 24.4 + 24.5 + 41.42 = 90.32 \text{ m}$$

©2005 Pearson Education South Asia Pte Ltd

### 13. Pump Selection and Applications

#### Example 13.4

**Step 7.** Total static head is

$$h_o = (p_2 - p_1)/\gamma + (z_2 - z_1) = 24.5 + 24.4 = 48.9 \text{ m}$$

**Step 8.** Pump selection: From Fig. 13.27; 2 x 3 —10 centrifugal pump operating at 3500 rpm. The desired operating point lies between the curves for the 8-in and 9-in impellers. We specify the 9-in impeller diameter so the capacity is greater than the minimum of 850 L/min or 0.014 m<sup>3</sup>/s.

(*Note:* Some manufacturers permit specifying any impeller diameter within the range given in the rating diagram.)

©2005 Pearson Education South Asia Pte Ltd

## 13. Pump Selection and Applications

### Example 13.4

**Step 9.** Points on the system curve are shown in Table 13.3, computed using the spreadsheet shown in Fig. 13.41 and varying the volume flow rate from zero to 1.1 m<sup>3</sup>/min.

**Step 10.** Figure 13.42 shows the system curve and the pump rating curve for the 9-in impeller on the same graph. The actual operating point is indicated.

©2005 Pearson Education South Asia Pte Ltd

## 13. Pump Selection and Applications

### Example 13.4

TABLE 13.3 System curve

| Q (m <sup>3</sup> /min) | h <sub>a</sub> (m) |
|-------------------------|--------------------|
| 0                       | 48.9               |
| 0.1                     | 49.3               |
| 0.2                     | 50.5               |
| 0.3                     | 52.5               |
| 0.4                     | 55.3               |
| 0.5                     | 58.9               |
| 0.6                     | 63.4               |
| 0.7                     | 68.7               |
| 0.8                     | 74.7               |
| 0.9                     | 81.6               |
| 1.0                     | 89.2               |
| 1.1                     | 97.7               |

©2005 Pearson Education South Asia Pte Ltd

## 13. Pump Selection and Applications

### Example 13.4

| APPLIED FLUID MECHANICS                                      |  | CLASS I SERIES SYSTEMS   |   |
|--|--|--|---|
| Objective: System Curve                                      |  | Reference points for the energy equation:                                  |   |
| Example Problem 13.4<br>Figure 13.40                         |  | Point 1: Surface of lower reservoir<br>Point 2: Surface of upper reservoir |   |
| System Data:   |  |  |   |
| U.S. Customary Units   |  |  |   |
| Volume flow rate: $Q = 0.014 \text{ m}^3/\text{s}$           | Elevation at point 1 = 0 m   | Elevation at point 2 = 24.4 m  |   |
| Pressure at point 1 = 0 Pa                                   | If Ref. pt. is in pipe: Set $v_1 = B20^\circ$ OR Set $v_2 = E20^\circ$ |  |   |
| Pressure at point 2 = 240 kPa                                | Vel. head at point 1 = 0 m   | Vel. head at point 2 = 0 m   |   |
| Velocity at point 1 = 0 m/s $\rightarrow$                    |  |  |   |
| Velocity at point 2 = 0 m/s $\rightarrow$                    |  |  |   |
| Fluid Properties:  |  |  |   |
| Specific weight = $9.8 \text{ kN/m}^3$                       | May need to compute $\nu = \mu/\rho$                                   |  |   |
|  | Kinematic viscosity = $1.12 \times 10^{-6} \text{ m}^2/\text{s}$       |  |   |
| Pipe 1: 3½-in Schedule 40 steel pipe                         |  | Pipe 2: 2½-in Schedule 40 steel pipe                                       |   |
| Diameter $D = 0.09 \text{ m}$                                | Diameter $D = 0.063 \text{ m}$   |  |   |
| Wall roughness: $\epsilon = 0.046 \text{ mm}$                | Wall roughness: $\epsilon = 0.046 \text{ mm}$                          |  |   |
| Length: $L = 2.44 \text{ m}$                                 | Length: $L = 109.7 \text{ m}$  |  |   |
| Area: $A = 6.381 \times 10^{-3} \text{ m}^2$                 | Area: $A = 0.00309 \text{ m}^2$  | [ $A = \pi D^2/4$ ]  |   |
| $D/\epsilon = 1866$  | $D/\epsilon = 1370$  | Rel. roughness   |   |
| $L/D = 27$   | $L/D = 1741$   |  |   |
| Flow velocity = 2.19 m/s                                     | Flow velocity = 4.53 m/s   | [ $v = Q/A$ ]  |   |
| Velocity head = 0.24 m                                       | Velocity head = 1.05 m   | [ $v^2/2g$ ]   |   |
| Reynolds No. = $1.76 \times 10^5$                            | Reynolds No. = $2.55 \times 10^5$                                      | [ $Re = VD/\nu$ ]  |   |
| Friction factor: $f = 0.0192$                                | Friction factor: $f = 0.0197$  | Using Eq. 9-7  |   |
| <b>Energy Losses in Pipe 1:</b>                              |  |  |   |
| Pipe: $K_f = 0.519$  | Qty: 1   | Total $K = 0.519$  | Energy loss $h_{L1} = 0.125 \text{ m}$  |
| Entrance: $K_2 = 0.500$                                      | Qty: 1   | Total $K = 0.500$  | Energy loss $h_{L2} = 0.120 \text{ m}$  |
| Gate valve: $K_3 = 0.198$                                    | Qty: 1   | Total $K = 0.798$  | Energy loss $h_{L3} = 0.039 \text{ m}$  |
| Element 4: $K_4 = 0.000$                                     | Qty: 1   | Total $K = 0.000$  | Energy loss $h_{L4} = 0.000 \text{ m}$  |
| Element 5: $K_5 = 0.000$                                     | Qty: 1   | Total $K = 0.000$  | Energy loss $h_{L5} = 0.000 \text{ m}$  |
| Element 6: $K_6 = 0.000$                                     | Qty: 1   | Total $K = 0.000$  | Energy loss $h_{L6} = 0.000 \text{ m}$  |
| Element 7: $K_7 = 0.000$                                     | Qty: 1   | Total $K = 0.000$  | Energy loss $h_{L7} = 0.000 \text{ m}$  |
| Element 8: $K_8 = 0.000$                                     | Qty: 1   | Total $K = 0.000$  | Energy loss $h_{L8} = 0.000 \text{ m}$  |
| <b>Energy Losses in Pipe 2:</b>                              |  |  |   |
| Pipe: $K_f = 34.489$   | Qty: 1   | Total $K = 34.489$   | Energy loss $h_{L1} = 36.212 \text{ m}$ |
| Entrance: $K_2 = 1.800$                                      | Qty: 1   | Total $K = 1.800$  | Energy loss $h_{L2} = 1.890 \text{ m}$  |
| Gate valve: $K_3 = 0.810$                                    | Qty: 1   | Total $K = 0.810$  | Energy loss $h_{L3} = 0.851 \text{ m}$  |
| Element 4: $K_4 = 0.540$                                     | Qty: 2   | Total $K = 1.080$  | Energy loss $h_{L4} = 1.134 \text{ m}$  |
| Element 5: $K_5 = 1.000$                                     | Qty: 1   | Total $K = 1.000$  | Energy loss $h_{L5} = 1.050 \text{ m}$  |
| Element 6: $K_6 = 0.000$                                     | Qty: 1   | Total $K = 0.000$  | Energy loss $h_{L6} = 0.000 \text{ m}$  |
| Element 7: $K_7 = 0.000$                                     | Qty: 1   | Total $K = 0.000$  | Energy loss $h_{L7} = 0.000 \text{ m}$  |
| Element 8: $K_8 = 0.000$                                     | Qty: 1   | Total $K = 0.000$  | Energy loss $h_{L8} = 0.000 \text{ m}$  |
| Total energy loss $h_{L\Sigma} = 41.420 \text{ m}$           |  |  |   |
| <b>Results:</b> Total head on pump: $h_p = 90.320 \text{ m}$ |  |  |   |

©2005 Pearson Education South Asia Pte Ltd

## 13. Pump Selection and Applications

### Example 13.4

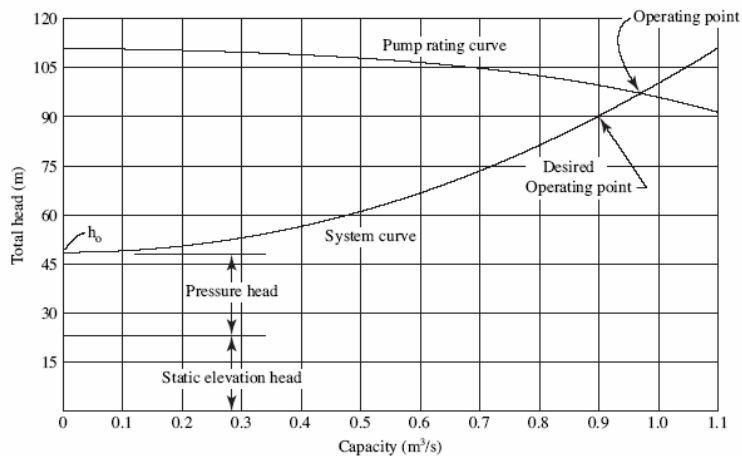

©2005 Pearson Education South Asia Pte Ltd

## 13. Pump Selection and Applications

### Example 13.4

**Step 11.** From the full chart of pump performance in Fig. 13.27, at the operating point:

2 × 3 – 10 centrifugal pump; 3500 rpm; 9.00-in impeller diameter  
Pump is mounted as shown in Fig. 13.10  
Suction port is 3 in; discharge port is 2 in  
Capacity =  $Q = 850$  L/s  
Total head  $h_a = 100$  m  
Efficiency = 57 percent  
Input power =  $P = 35$  HP = 25.9 kW  
 $NPSH_R = 2.4$  m

©2005 Pearson Education South Asia Pte Ltd

## 13. Pump Selection and Applications

### Example 13.4

**Step 12.**

$$NPSH_A = h_{sp} \pm h_s - h_f - h_{vp}$$

Assume  $p_{sp} = 101.3$  kPa (atmospheric) above the water in the source reservoir. Then,

$$p_{sp} = \frac{p_{sp}}{\gamma} = 101.3 \text{ kPa} / 9.8 \text{ kN/m}^3 = 10.33 \text{ m}$$

$$h_s = + 2.4 \text{ m} \quad (\text{positive because the pump is below source level})$$

$$h_f = \text{Total energy loss in suction line} = \text{Entrance loss} + \text{Loss in valve} + \text{Loss in pipe}$$

$$h_f = 0.125 + 0.12 + 0.033 = 0.278 \text{ m} \quad (\text{values found in Fig. 13.41})$$

$$h_{vp} = 0.1821 \text{ m} \quad (\text{from Table 13.2})$$

$$NPSH_A = 10.33 + 2.4 - 0.278 - 0.1821 = 12.27 \text{ m}$$

©2005 Pearson Education South Asia Pte Ltd

## 13. Pump Selection and Applications

### Example 13.4

#### Step 13. Compute

$$1.10NPSH_R = 1.10(2.4) = 2.64 \text{ m}$$

$$NPSH_A > 1.10NPSH_R \quad (\text{OK})$$

©2005 Pearson Education South Asia Pte Ltd

## 13. Pump Selection and Applications

### Example 13.4

**Step 14.** The sizes of the suction and discharge pipes are different from the sizes of the pump ports. A gradual reducer must be used from the 3.5-in suction pipe to the 3-in suction port. A gradual enlargement must be used from the 2-in discharge port to the 2.5-in discharge pipe. The diameter ratio for each is approximately 1.2. Referring to Fig. 10.5 for a gradual enlargement and Fig. 10.10 for a gradual reducer, and specifying a  $15^\circ$  included angle, we find the  $K$  value will be 0.09 for the enlargement and 0.03 for the reducer. The additional energy losses are

©2005 Pearson Education South Asia Pte Ltd



## 13. Pump Selection and Applications

### Example 13.4

$$h_{LS} = 0.03(v^2/2g) = 0.03(0.24 \text{ m}) = 0.0072 \text{ m}$$

$$h_{Ld} = 0.09(v^2/2g) = 0.09(1.05 \text{ m}) = 1.14 \text{ m}$$

These values are negligible compared to the other energy losses in the suction and discharge lines and therefore should not significantly affect the pump selection or its performance.

©2005 Pearson Education South Asia Pte Ltd

## 13. Pump Selection and Applications

### 13.14 Alternate System Operating Modes

- What happens if the speed of the pump varies?
- What if the fluid has a significantly higher or lower viscosity than water?
- What if we want to use two or more pumps in parallel to feed a system?
- What happens if we connect pumps in series where the output from one feeds to the input of the next?

©2005 Pearson Education South Asia Pte Ltd

## 13. Pump Selection and Applications

### 13.14.1 Variable Speed Drives

- Variable-speed drives offer an attractive alternative to throttling.
- Several types of mechanical variable-speed drives and a variable-frequency electronic control for a standard AC electric motor are available.
- The effect of implementing a variable-speed drive for a system with a centrifugal pump depends on the nature of the system curve as shown in Fig. 13.43.
- Part (a) shows a system curve that includes only friction losses.
- The system curve in part (b) includes a substantial static head comprised of an elevation change and pressure change from the source to the destination.

©2005 Pearson Education South Asia Pte Ltd

## 13. Pump Selection and Applications

### 13.14.1 Variable Speed Drives

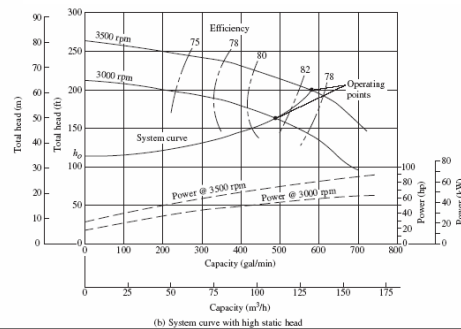
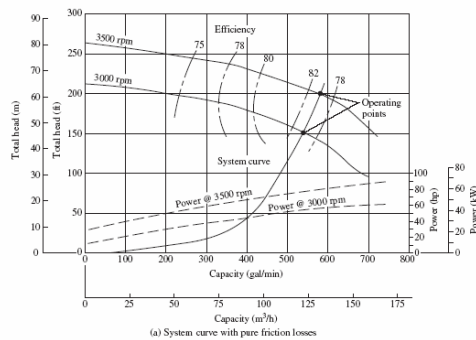

©2005 Pearson Education South Asia Pte Ltd

## 13. Pump Selection and Applications

### 13.14.1 Variable Speed Drives

- In addition to energy savings, other benefits result from using variable-speed drives:
  1. *Improved process control* Pump delivery can be matched closely to requirements, resulting in improved product quality.
  2. *Control of rate of change* Variable-speed drives control not only the final speed, but also the rate of change of speed, reducing pressure surges.
  3. *Reduced wear* Lower speeds dramatically reduce forces on seals and bearings, resulting in longer life and greater reliability of the pumping system.

©2005 Pearson Education South Asia Pte Ltd

## 13. Pump Selection and Applications

### 13.14.2 Effect of Fluid Viscosity

- The performance rating curves for centrifugal pumps are generated from test data using water as the fluid.
- These curves are reasonably accurate for any fluid with a viscosity similar to that of water.
- However, pumping more-viscous fluids causes the following effects:
  1. The power required to drive the pump increases
  2. The flow delivered against a given head decreases
  3. The efficiency decreases

©2005 Pearson Education South Asia Pte Ltd

### 13. Pump Selection and Applications

#### 13.14.2 Effect of Fluid Viscosity

- Figure 13.44 illustrates the effect of pumping a viscous fluid if the pump was selected for the desired operating point without applying corrections.

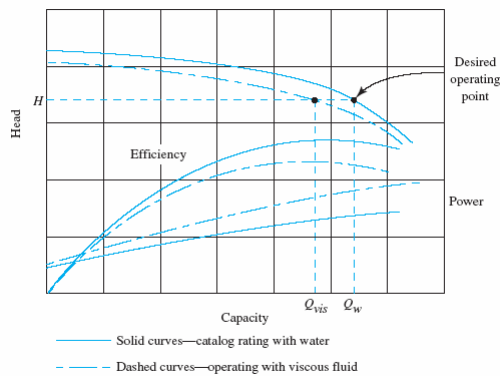

©2005 Pearson Education South Asia Pte Ltd

### 13. Pump Selection and Applications

#### 13.14.3 Operating Pumps in Parallel

- Many fluid flow systems require largely varying flow rates that are difficult to provide with one pump without calling for the pump to operate far off its best efficiency point.
- Fig 13.45 shows the performance of two pumps in parallel.

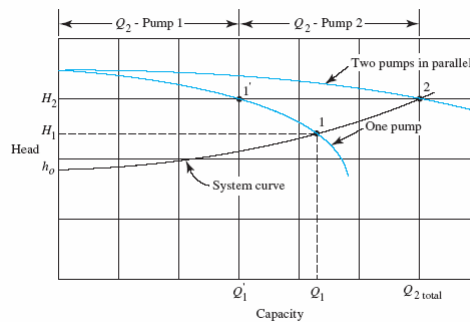

©2005 Pearson Education South Asia

## 13. Pump Selection and Applications

### 13.14.4 Operating Pumps in Series

- Directing the output of one pump to the inlet of a second pump allows the same capacity to be obtained at a total head equal to the sum of the ratings of the two pumps.
- This method permits operation against unusually high heads.
- Fig 13.46 shows the performance of two pumps operating in series.

©2005 Pearson Education South Asia Pte Ltd

## 13. Pump Selection and Applications

### 13.14.4 Operating Pumps in Series

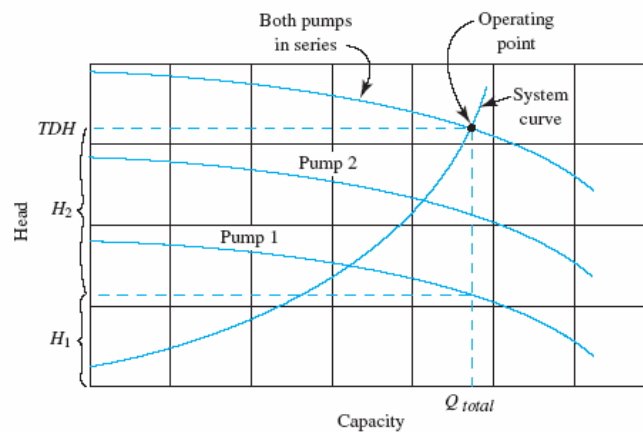

©2005 Pearson Education South Asia Pte Ltd

## 13. Pump Selection and Applications

### 13.14.5 Multistage Pump

- A performance similar to that achieved by using pumps in series can be obtained by using multistage pumps.
- Two or more impellers are arranged in the same housing in such a way that the fluid flows successively from one to the next.
- Each stage increases the fluid pressure, so that a high total head can be developed.

©2005 Pearson Education South Asia Pte Ltd

## 13. Pump Selection and Applications

### 13.15 Pump Selection and Specific Speed

- Figure 13.47 shows one method for deciding what type of pump is suitable for a given service.

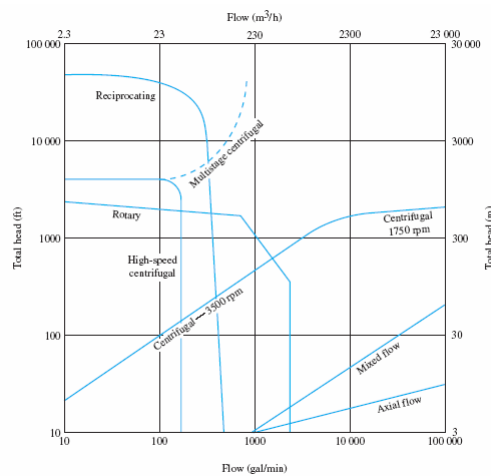

©2005 Pearson Education South Asia Pte Ltd

## 13. Pump Selection and Applications

### 13.15 Pump Selection and Specific Speed

- Another parameter that is useful in selecting the type of pump for a given application is the *specific speed*, defined as

$$N_s = \frac{N\sqrt{Q}}{H^{3/4}} \quad (13-17)$$

$N$  = Rotational speed of the impeller (rpm)

$Q$  = Flow rate through the pump (liters/s or gal/min)

$H$  = Total head on the pump (m or ft)

©2005 Pearson Education South Asia Pte Ltd

## 13. Pump Selection and Applications

### 13.15 Pump Selection and Specific Speed

- The specific speed is often combined with the *specific diameter* to produce a chart like that shown in Fig. 13.48. The specific diameter is

$$D_s = \frac{DH^{1/4}}{\sqrt{Q}} \quad (13-18)$$

- where  $D$  is the impeller diameter in inches.

©2005 Pearson Education South Asia Pte Ltd

## 13. Pump Selection and Applications

### 13.16 Life Cycle Costs for Pumped Fluid Systems

- The term *life cycle cost* (LCC) refers here to the consideration of all factors that make up the cost of acquiring, maintaining, and operating a pumped fluid system.
- Good design practice seeks to minimize LCC by quantifying and computing the sum of the following factors:
  1. Initial cost to purchase the pump, piping, valves and other accessories, and controls.
  2. Cost to install the system and put it into service.

©2005 Pearson Education South Asia Pte Ltd

## 13. Pump Selection and Applications

### 13.16 Life Cycle Costs for Pumped Fluid Systems

3. Energy cost required to drive the pump and auxiliary components of the system over the expected life.
4. Operating costs related to managing the system including labor and supervision.
5. Maintenance and repair costs over the life of the system to keep the pump operating at design conditions.
6. Cost of lost production of a product during pump failures or when the pump is shut down for maintenance.
7. Environmental costs created by spilled fluids from the pump or related equipment.
8. Decommissioning costs at the end of the useful life of the pump including disposal of the pump and cleanup of the site.

©2005 Pearson Education South Asia Pte Ltd



## 13. Pump Selection and Applications

### 13.16 Life Cycle Costs for Pumped Fluid Systems

3. Energy cost required to drive the pump and auxiliary components of the system over the expected life.
4. Operating costs related to managing the system including labor and supervision.
5. Maintenance and repair costs over the life of the system to keep the pump operating at design conditions.
6. Cost of lost production of a product during pump failures or when the pump is shut down for maintenance.
7. Environmental costs created by spilled fluids from the pump or related equipment.
8. Decommissioning costs at the end of the useful life of the pump including disposal of the pump and cleanup of the site.

©2005 Pearson Education South Asia Pte Ltd

## 13. Pump Selection and Applications

### 13.16 Life Cycle Costs for Pumped Fluid Systems

- When using SI units to determine specific speed,  $NS$ , the following ranges are used for pump classifications:

|             |               |
|-------------|---------------|
| Radial Flow | $\leq 2600$   |
| Mixed Flow  | $2600 - 5000$ |
| Radial Flow | $> 5000$      |

- Fig 13.48 shows the specific speed versus specific diameter for centrifugal pumps—An aid to pump selection.

©2005 Pearson Education South Asia Pte Ltd

## 13. Pump Selection and Applications

### 13.16 Life Cycle Costs for Pumped Fluid Systems

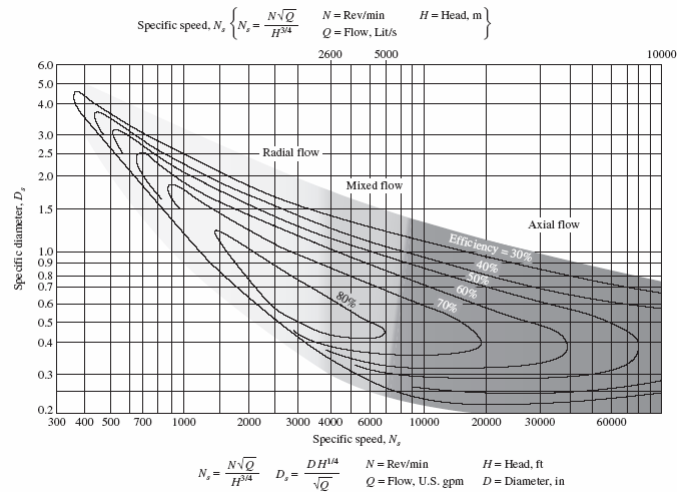

©2005 Pearson Education South Asia Pte Ltd

## 13. Pump Selection and Applications

### 13.16.1 Minimizing Energy Costs

- For pumps that operate continuously for long periods of time, the energy cost is the highest component of the total life cycle cost.
- Some of the considerations:
  1. Perform a careful, complete analysis of the proposed design for the piping system to understand where energy losses occur and to predict accurately the design operating point for the pump.
  2. Recognize that energy losses in piping, valves, and fittings are proportional to the velocity head, that is, to the square of the flow velocity.

©2005 Pearson Education South Asia Pte Ltd

## 13. Pump Selection and Applications

### 13.16.1 Minimizing Energy Costs

2. Use the largest practical size of pipe for both the suction and discharge lines of the system to keep the flow velocity at a minimum. Fig 13.49 shows the life-cycle cost principle for pumped fluid distribution systems.

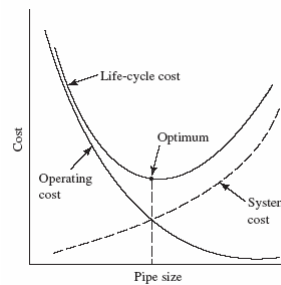

©2005 Pearson Education South Asia Pte Ltd

## 13. Pump Selection and Applications

### 13.16.1 Minimizing Energy Costs

3. Use the largest practical size of pipe for both the suction and discharge lines of the system to keep the flow velocity at a minimum.
4. Carefully match the pump to the head and capacity requirements of the system to ensure that the pump operates at or near its best efficiency point (*BEP*) and to avoid using an oversized pump that will cause it to operate at a lower efficiency.
5. Use the most efficient pump for the application and operate the pump as close as possible to its *BEP*.

©2005 Pearson Education South Asia Pte Ltd

## 13. Pump Selection and Applications

### 13.16.1 Minimizing Energy Costs

6. Use high-efficiency electric motors or other prime movers to drive the pump.
7. Consider the use of variable-speed drives (VSD) for the pumps to permit matching the pump delivery to the requirements of the process.
8. Consider two or more pumps operating in parallel for systems requiring widely varying flow rates.
9. Provide diligent maintenance of the pump and piping system to minimize the decrease in performance due to wear, build-up of corrosion on pipe surfaces, and fluid leakage.

©2005 Pearson Education South Asia Pte Ltd

## 13. Pump Selection and Applications

### 13.17 Software for Piping System Design and Pump Selection

- Steady or unsteady flow, stress analysis, and dynamic response of the piping system are sometimes included.
- Specialized software sets for spraying systems and fire protection systems are also offered.
- Such software packages allow the consideration of multiple design proposals to hone in on the optimum system for the application, taking much of the computational burden.

©2005 Pearson Education South Asia Pte Ltd

## 13. Pump Selection and Applications

### 13.17.1 Use of the Pumpbase Pump Selection Software

- The PumpBase software requires only a few input data points, such as total dynamic head ( $TDH$ ) [Eq. (13–1)] at the design flow rate and static head [Eq. (13–11)].
- The system curve is automatically generated by fitting a second-degree curve through these two known points.
- PumpBase also allows the input of a limiting value of  $NPSH$  required by the pump, and it will then screen out any pump requiring a greater value.