

VARIOUS TYPES OF CENTRIFUGAL PENDULUM DETUNERS

Notation: Ω =phase velocity of shaft rotation, $T_{(n)}$ =excitation torque (nth order critical), $m_1 = W_1/g$ =mass of pendulum, J_G =moment of inertia of m_1 about its centre of gravity G , n =order number of critical speed [vib./rev.], θ_2 =vibration amplitude of carrier (of inertia J_2). With resonance tuning: $\theta_2=0$, for all pendulums considered.

Simple ('Mathematical') pendulum

$$\overline{OA} = R, \overline{AG} = r$$

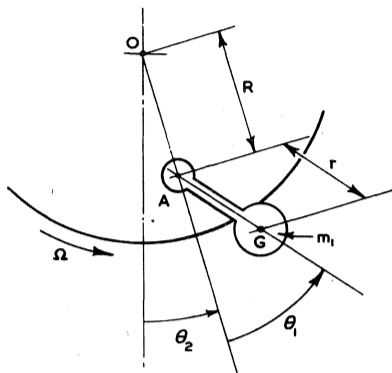

Tuning ratio:

$$n^2 = \frac{R}{r}$$

Vibration amplitude of pendulum (at resonance tuning):

$$\theta_1 = \frac{T_{(n)}}{m_1(R+r)rn^2\Omega^2}$$

Response to any other nth order excitation torque $T_{(n)}$: Vibration amplitude of pendulum m_1 :

$$\theta_1 = \frac{(R/r)+1}{1-\frac{R}{rn^2}} \times \theta_2$$

Vibration amplitude of carrier J_2 :

$$\theta_2 = T_{(n)} / [K_2 - \omega^2 J_2 - \omega^2 J_{P\text{eff.}}]$$

where

$$J_{P\text{eff.}} = m_1(R+r)^2 \times \left[1 + \frac{1}{\frac{R}{rn^2} - 1} \right]$$

Alternative designations:

Other remarks:

'Bifilar' pendulum

$$\overline{OA} = R \text{ (where } A = \text{effective point of suspension)}$$

$$\overline{AG} = r = D - d$$

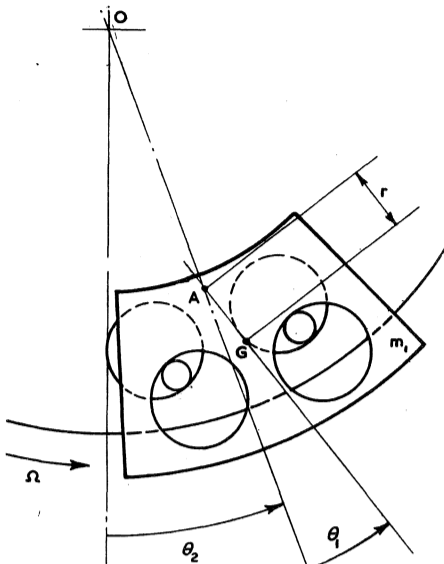

d = diameter of rollers
 D = diameter of holes

$$n^2 = \frac{R}{r}$$

$$\theta_1 = \frac{T_{(n)}}{m_1(R+r)rn^2\Omega^2}$$

$$\theta_1 = \frac{(R/r) \times 1}{1 - \frac{R}{rn^2}} \times \theta_2$$

$\theta_2 = T_{(n)} / [K_2 - \omega^2 J_2 - \omega^2 J_{P\text{eff.}}]$, where

$$J_{P\text{eff.}} = J_G + m_1 \frac{(R+r)^2}{1 - \frac{r}{R} n^2}$$

Sarazin pendulum
Chilton pendulum
Taylor pendulum

All holes of equal radius

Roller-type pendulum

$$\overline{OA} = R, r = (D-d)/2$$

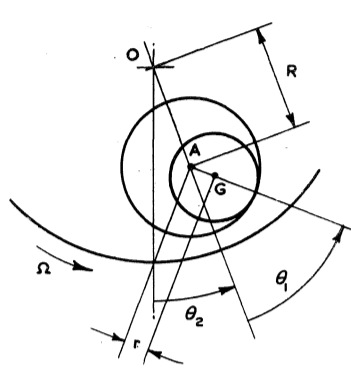

m_1 = mass of roller
 D = diameter of cavity
 d = diameter of roller
 A = centre of cavity

$$n^2 = \frac{R}{r} \times \frac{1}{\left[1 + \frac{4J_G}{m_1 d^2} \right]}$$

$$\theta_1 = \frac{T_{(n)}}{\left[m_1(R+r) - \frac{2J_G}{d} \right] rn^2\Omega^2}$$

$$\theta_1 = \frac{1 + (R/r) - (2J_G/m_1 d r)}{1 + \frac{4J_G}{m_1 d^2} - \frac{R}{rn^2}} \times \theta_2$$

$\theta_2 = T_{(n)} / [K_2 - \omega^2 J_2 - \omega^2 J_{P\text{eff.}}]$, where

$$J_{P\text{eff.}} = J_G + m_1(R+r)^2 - \frac{m_1(R+r - \frac{2J_G}{m_1 d})^2}{1 + \frac{4J_G}{m_1 d^2} - \frac{R}{n^2 r}}$$

Salomon pendulum

Ring-type pendulum

$$\overline{OA} = R, r = (D-d)/2$$

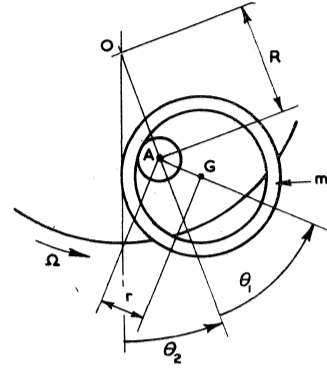

m_1 = mass of ring
 D = inner diameter of ring
 d = pin diameter
 A = centre of pin

$$n^2 = \frac{R}{r} \times \frac{1}{\left[1 + \frac{4J_G}{m_1 D^2} \right]}$$

$$\theta_1 = \frac{T_{(n)}}{\left[m_1(R+r) + \frac{2J_G}{D} \right] rn^2\Omega^2}$$

$$\theta_1 = \frac{1 + (R/r) + (2J_G/m_1 D r)}{1 + \frac{4J_G}{m_1 D^2} - \frac{R}{rn^2}} \times \theta_2$$

$\theta_2 = T_{(n)} / [K_2 - \omega^2 J_2 - \omega^2 J_{P\text{eff.}}]$, where

$$J_{P\text{eff.}} = J_G + m_1(R+r)^2 - \frac{m_1(R+r + \frac{2J_G}{m_1 D})^2}{1 + \frac{4J_G}{m_1 D^2} - \frac{R}{n^2 r}}$$

Salomon pendulum

Composite-type pendulum (roller and ring)

$$\overline{OA} = R, r \approx D - d$$

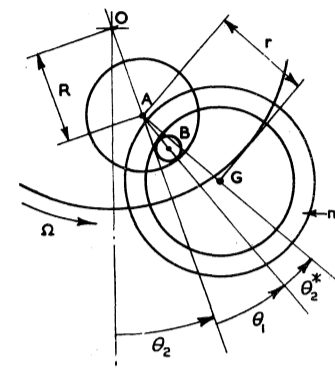

m_1 = mass of ring
 D = inner diameter of ring and diameter of cavity
 d = roller diameter

Two modes of vibration:
(I) 'Rigid-pendulum' motion (with ABG =straight line, hence $\theta_2^* = 0$):

$$n_{(I)}^2 = R/r$$

$$\theta_1 = \frac{T_{(n)}}{m_1(R+r)rn^2\Omega^2}$$

(II) 'Anti-phase pendulums' motion:

$$n_{(II)}^2 = \left(1 + \frac{R}{r} \right) \left(\frac{m_1 D^2}{4J_G} \right)$$

$$\theta_1 = -T_{(n)} / \left[2J_G \frac{r}{D} n^2 \Omega^2 \right]$$

$$\theta_2^* = -2\theta_1$$

Note. Usually, $n_{(II)} < n_{(I)}$; in practice only $n_{(I)}$ is used because in many cases $n_{(II)}$ is unstable, with excessive pendulum amplitudes.

$$\theta_1 = -\frac{(R/r)+1}{1 - \frac{R}{n^2 r}} \times \theta_2 - \frac{1}{2} \theta_2^*$$

$$\theta_2^* = \frac{-D/r}{1 - \frac{(R/r)+1}{n^2} \times \frac{m_1 D^2}{4J_G}} \times \theta_2$$

$\theta_2 = T_{(n)} / [K_2 - \omega^2 J_2 - \omega^2 J_{P\text{eff.}}]$, where

$$J_{P\text{eff.}} = \frac{m_1(R+r)^2}{1 - \frac{n^2 r}{R}} + \frac{J_G}{1 - \frac{r}{R+r} \times \frac{4J_G}{n^2 m_1 D^2}}$$

'Duplex' pendulum

Above formulae are strictly applicable when roller inertia $J_{\text{roll.}} \approx \frac{1}{4} m_{\text{roll.}} \times d^2$, where $m_{\text{roll.}}$ = mass of roller

Examples of detuner arrangements:

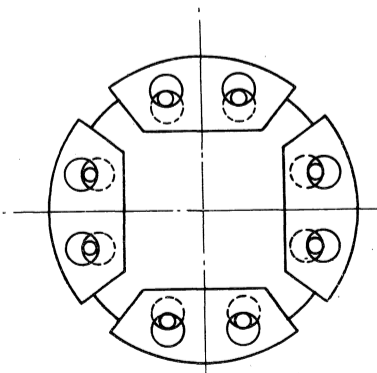

Bifilar type

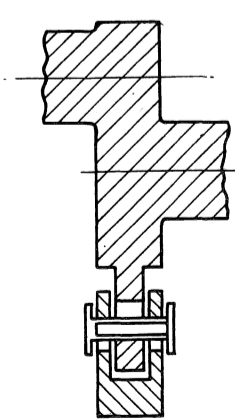

Bifilar type

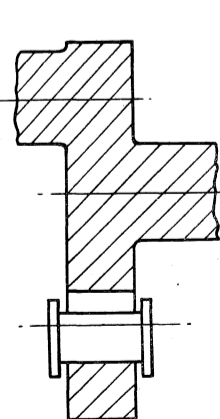

Roller type

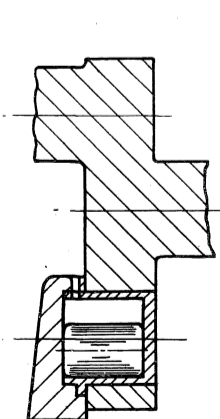

Roller type

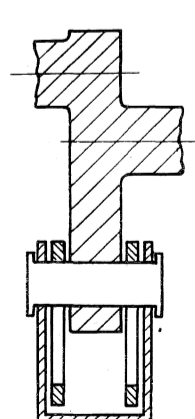

Ring type

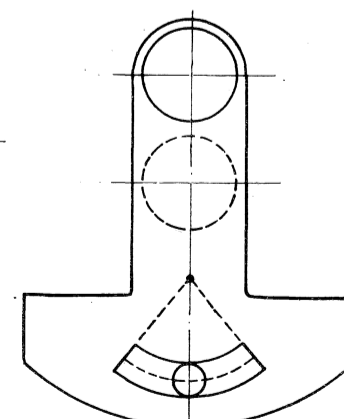

Roller type (or ball type)

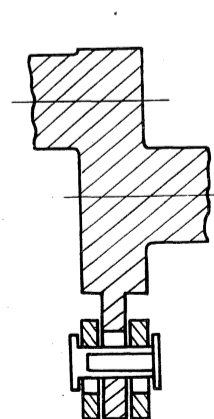

Composite (roller and rings) type