Meridian 1

Serial Data Interface Cards

Description

Document Number: 553-3001-107

Document Release: Standard 7.00

Date: January 2002

Copyright © 1994 – 2002 Nortel Networks

All Rights Reserved

Printed in Canada

Information is subject to change without notice. Nortel Networks reserves the right to make changes in design or components as progress in engineering and manufacturing may warrant. This equipment has been tested and found to comply with the limits for a Class A digital device pursuant to Part 15 of the FCC rules, and the radio interference regulations of Industry Canada. These limits are designed to provide reasonable protection against harmful interference when the equipment is operated in a commercial environment. This equipment generates, uses and can radiate radio frequency energy, and if not installed and used in accordance with the instruction manual, may cause harmful interference to radio communications. Operation of this equipment in a residential area is likely to cause harmful interference in which case the user will be required to correct the interference at their own expense.

SL-1 and Meridian 1 are trademarks of Nortel Networks.

Revision history

January 2002

Standard 7.00. This document is up-issued to include content changes for the Meridian 1 Internet Enabled Release 25.40.

April 2000

Standard 6.00. This is a global document and is up-issued for X11 Release 25.0x.

October 1997

Standard, Release 5.00. This document is reissued to provide information about the four-port SDI paddleboard (NT8D41BA). The NT8D41AA two-port SDI paddle board is being phased out.

December 1995

Standard, Release 4.00. This document is reissued to include the Option 81C corrections. Changes are noted by revision bars in the margin.

July 1995

Standard, Release 3.00. This document is reissued to include the Option 81C switch. Changes are noted by revision bars in the margin.

December 1994

Standard, Release 2.00. Reissued to include editorial changes and indexing. Due to the extent of the changes, revision bars are not used.

April 1994

Standard, Release 1.00. This is the initial issue of this document. It includes information formerly contained in NTPs 553-2201-192, 553-2201-195, and 553-3001-181 which are herewith retired.

Contents

About this document	7
General information	9
Contents	9
Reference list	9
Overview	10
Uses	11
Features	12
Specifications	13
Installation	14
Maintenance	15
NT8D41AA Serial Data Interface Paddle Board ..	17
Contents	17
Reference list	17
Physical description	18
Functional description	20
Connector pin assignments	22
Configuring the SDI paddle board	23
Applications	28
NT8D41BA Quad Serial Data Interface Paddle Board	31
Contents	31

Reference list	31
Physical description	32
Functional description	34
Connector pin assignments	36
Configuring the QSDI paddle board	37
Applications	41
QPC841 Quad Serial Data Interface Card	43
Contents	43
Reference list	43
Physical description	44
Functional description	45
Connector pin assignments	48
Configuring the QSDI card	50
Applications	55
QPC513 Enhanced Serial Data Interface Card ..	57
Contents	57
Reference list	57
Physical description	59
Functional description	61
Connector pin assignments	67
Configuring the ESDI card	69
Applications	74
Contents	77
Index	83

About this document

This document is a global document. Contact your system supplier or your Nortel Networks representative to verify that the hardware and software described is supported in your area.

This document describes the Serial Data Interface (SDI) cards that are used in the Meridian 1 system:

- NT8D41AA Serial Data Interface (SDI) paddle board
- NT8D41BA Quad Serial Data Interface (QSDI) paddle board
- QPC841 Quad Serial Data Interface (QSDI) Card
- QPC513 Enhanced Serial Data Interface (ESDI) Card

This manual provides the following reference material at the back of the book:

- LAPB data link control protocol
- List of terms

References

See the Meridian 1 Planning and Engineering guide for:

- *Spares Planning* (553-3001-153)
- *Equipment Identification* (553-3001-154)

See Meridian 1 *Software Input/Output Guide Administration* (553-3001-311) for a description of all administration programs and maintenance programs. Refer to Meridian 1 *Software Input/Output Guides Message Guide* (553-3001-411) for a description of system messages.

See *System Installation Procedures* (553-3001-210) for a description of the serial data interface cross-connections and cabling.

General information

Contents

This section contains information on the following topics:

Overview.	10
Uses.	11
Features.	12
Specifications.	13
Power consumption.	13
Environmental.	13
Electrostatic discharge.	14
Electromagnetic interference.	14
Reliability.	14
Installation.	14
Installing the card.	14
Configuring the system software.	14
Maintenance.	15

Reference list

The following are the references in this section:

- *System Installation Procedures (553-3001-210)*
- *Circuit Card: Installation and Testing (553-3001-211)*
- *Software Input/Output Guide Administration (553-3001-311)*
- *Software Input/Output Guides Message Guide (553-3001-411)*

Overview

The Nortel Networks Serial Data Interface (SDI) cards described in this document are the NT8D41AA SDI paddle board, the NT8D41BA QSDI paddle board, the QPC841 Quad Serial Data Interface (QSDI) Card, and the QPC513 Enhanced Serial Data Interface (ESDI) Card (synchronous).

The NT8D41BA QSDI paddle board provides four bidirectional asynchronous serial ports for the Meridian 1 system processor, and the QPC841 QSDI Card also provides four. Any device that conforms to the RS-232-C serial communication standard can be connected to these serial ports.

The QPC513 ESDI Card provides two fully synchronous serial ports for the Meridian 1 system processor. The ESDI card communicates using the Link Access Procedure Balanced (LAP-B) synchronous communications protocol.

The electrical interface uses either standard RS-232-C signals or a special high-speed interface that combines the high-speed differential interface of the RS-422-A standard with the handshake signals of the RS-232-C standard.

The RS-232-C interface is normally used when data rates are less than 19.2 kbps, and the cable length is less than 15.24 m (50 ft). The high-speed interface is used when the signal rates are greater than 19.2 kbps (up to 64 kbps) and/or when the cable length is greater than 15.24 m (50 ft).

Table 1 shows compatibility between the three SDI cards and the various Meridian 1 switch options.

Table 1
Serial data interface cards

Card	Ports	Port types	Compatible Meridian 1 options:		
			21, 21A, 21E	51, 51C, 61, 61C	71, 81, 81C
NT8D41BA	4	RS-232-C asynchronous		X	X
QPC841	4	RS-232-C asynchronous	X	X	X
QPC513	2	RS-232-C synchronous or high-speed synchronous*	X	X	X

*See the section on the QPC513 card in this manual for details on the high-speed interface

The NT8D41BA QSDI paddle board does not have a front panel. It mounts to the rear of the backplane in the NT5D21 Core/Network Module, and does not consume a module slot. The RS-232-C connections are brought out through special cables to the backplane I/O panel.

The QPC841 Quad SDI Card and the QPC513 Enhanced SDI Card mount in standard backplane slots, and their serial interface connectors are located on the card front panels. A list of the modules that they can be mounted in is given in the following sections on the individual cards.

Uses

Examples of asynchronous devices that can be connected to the Meridian 1 system processor using the NT8D41BA QSDI paddle board and the QPC841 Quad SDI Card are:

- an administration and maintenance terminal
- a background terminal for use in a hotel/motel
- the Meridian 1 Automatic Call Distribution (ACD) feature
- the Meridian 1 Call Detail Recording (CDR) feature

Examples of synchronous devices that can be connected to the Meridian 1 system processor using the QPC513 Enhanced SDI Card are:

- a host computer (DEC, Tandem, for example) using the Meridian Link communications program
- the Meridian Mail voice-mail option

Features

The NT8D41 QSDI paddle board and the QPC841 QSDI Card provide the following features:

- asynchronous serial data interface ports, each supporting
 - RS-232-C interface
 - 8-bit ASCII data with parity and stop bit
 - Asynchronous, start-stop operation
 - Data rates of 150, 300, 600, 1200, 2400, 4800, and 9600 baud
 - Data terminal equipment (DTE) emulation mode
 - Data communication equipment (DCE) emulation mode
- enable/disable switch and LED
- input/output (I/O) device address selectable by on-board switches.

The QPC513 ESDI Card provides these features:

- fully synchronous serial data interface ports, each supporting
 - RS-232-C or modified RS-422-A interface
 - LAPB subset of the HDLC synchronous protocol
 - Data rates of 1200, 2400, 4800, 9600, 19200, 48000, 56000, and 64000 baud
 - Data terminal equipment (DTE) emulation mode
 - Data communication equipment (DCE) emulation mode
- enable/disable switch and LED

- input/output (I/O) device address selectable by on-board switches.

Specifications

This section lists the specifications shared by all of the SDI cards. See the appropriate section in this document for information specific to any particular card.

Power consumption

The SDI cards obtain their power directly from the module backplane. Power consumption for each of the cards is shown in Table 2.

Table 2
Power consumption

Voltage	Maximum power consumption		
	NT8D41BA	QPC513	QPC841
+5 VDC $\pm 5\%$	1.0 Amp	3.0 Amp	1.5 Amp
+12 VDC $\pm 5\%$	100 mA	50 mA	100 mA
-12 VDC $\pm 5\%$	100 mA	50 mA	100 mA

Environmental

The SDI cards operate without degradation under the conditions listed in Table 3.

Table 3
Environmental specifications

Specification	Operation	Storage
Ambient temperature	0° to 50°C; (32° to 122°F)	-55° to +70°C; (-58° to 158°F)
Relative humidity (non-condensing)	5% to 95%	0% to 95%
Altitude	3500m; (11000 ft)	15000m; (50000 ft)

Electrostatic discharge

The SDI cards meet the requirements of the IEC 801-2, clause 8.0 procedure. They can withstand a direct discharge of ± 5 to ± 20 kV without being damaged.

Electromagnetic interference

The Meridian 1 system meets the requirements of FCC Part 15 and CSA C108.8 electromagnetic interference (EMI) standards as a class “A” computing device. To accomplish this, the SDI cables must exit the module through EMI filters on the I/O panel.

Reliability

The Mean Time Between Failure (MTBF) for all SDI cards is 55 years at 40°C and 29 years at 55°C.

Installation

To use a serial data interface card in a Meridian 1 system, first install the card in the system, and then configure the system software to recognize it. These steps are discussed in the following sections.

Installing the card

Instructions for installing the serial data interface cards are found in *Circuit Card: Installation and Testing* (553-3001-211).

Instructions for cabling the serial data interface cards to the various system consoles and peripherals are found in *System Installation Procedures* (553-3001-210).

Configuring the system software

Once an SDI card has been installed in the system, the system software needs to be configured to recognize it. This is done using the Configuration Record program LD 17. Instructions for the Configuration Record program are found in *Software Input/Output Guide Administration* (553-3001-311).

Maintenance

The following maintenance programs are used to maintain individual SDI asynchronous ports. The program used depends on the application of the port.

- LD 37 Input/Output Diagnostics – Used for system terminal, printer, background terminal ports, and system monitor status.
- LD 42 Call Detail Recording (CDR) Diagnostic – For checking CDR links and CDR system terminals.

The following maintenance program is used to maintain individual SDI synchronous ports.

- LD 48 Link Diagnostic – For checking Automatic Call Distribution (ACD) and Meridian Link ports.

Instructions for running the various maintenance programs are found in *Software Input/Output Guide Administration* (553-3001-311). System messages are interpreted in *Software Input/Output Guides Message Guide* (553-3001-411).

NT8D41AA Serial Data Interface Paddle Board

Contents

This section contains information on the following topics:

Physical description.	18
Functional description.	20
System considerations.	21
Connector pin assignments.	22
Configuring the SDI paddle board.	23
Option switch settings.	23
Software service changes.	25
Applications.	28

Reference list

The following are the references in this section:

- *Software Input/Output Guide Administration* (553-3001-311)

The NT8D41AA Serial Data Interface (SDI) paddle board provides two RS-232-C serial ports. These ports allow communication between the Meridian 1 system and two external devices. The SDI paddle board is usually used to connect the Meridian 1 system to the system administration and maintenance terminal. It can also be used to connect the system to a background terminal (used in the hotel/motel environment), a modem, or to the Automatic Call Distribution (ACD) or Call Detail Recording (CDR) features.

The SDI paddle board mounts to a special socket on the rear of the backplane of the following modules:

- NT5D21 Core/Network Module for system Options 51C, 61C, and 81C
- NT6D39 CPU/Network Module for system Options 51 and 61
- NT8D11 Common/Peripheral Equipment (CE/PE) Module for system Options 21, 21A, and 21E
- NT9D11 Core/Network Module for system Option 61C

The SDI paddle board is compatible with all existing system software, but can only be used with the Meridian 1 system options listed above. It does not support 20 mA current loop interface.

Physical description

The NT8D41AA Serial Data Interface paddle board is a printed circuit board measuring 31.12 by 12.7 cm (12.25 by 5.0 in.). See Figure 1 on page 19.

Up to two paddle boards can be used in a system backplane for a total of four serial ports. Up to 12 other serial ports can be added by plugging standard serial cards into standard system slots. The two serial ports on each card are addressed as a pair of consecutive addresses (0 and 1, 2 and 3, up to 14 and 15).

The front edge of the card has two serial port connectors, an Enable/Disable switch (ENB/DIS), and a red LED. The LED indicates that the card has been disabled. It is lit when the following occurs:

- the ENB/DIS switch is set to disable
- both ports are disabled in software
- the ports are not configured in the configuration record

Figure 1
NT8D41AA SDI paddle board

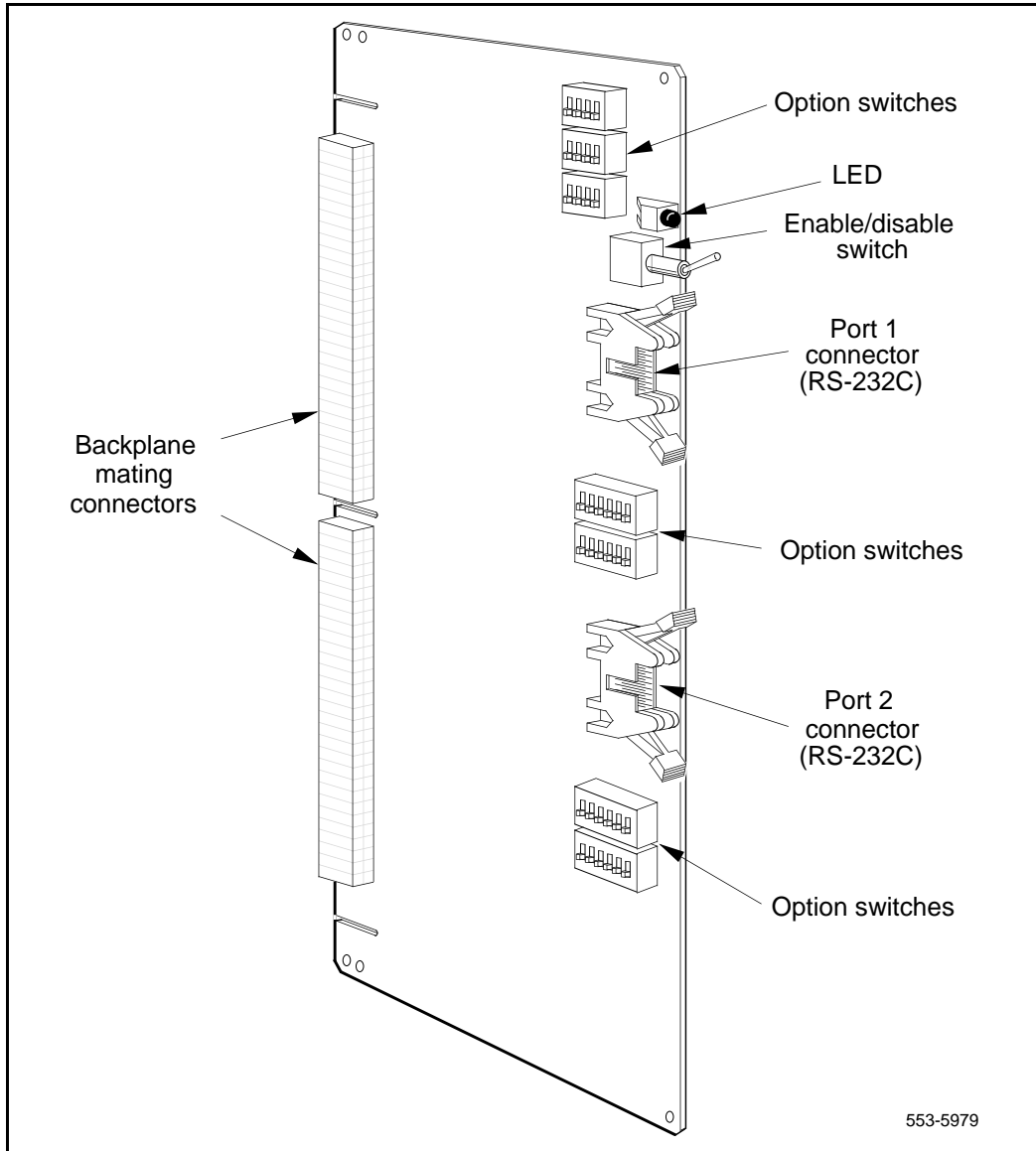

Functional description

The NT8D41AA SDI paddle board has two asynchronous serial ports. These serial ports are connected to the I/O panel in the back of the shelf using special adapter cables. The serial ports can be used to connect the Meridian 1 system to a terminal, a printer, a modem, or to another system processor.

The SDI paddle board contains two Universal Asynchronous Receiver/Transmitters (UARTs) and the logic necessary to connect the UARTs to the system processor bus. See Figure 2. Other logic on the card includes two baud rate generators, two RS-232-C driver/receiver pairs, and the switches and logic needed to configure the UARTs.

Figure 2
NT8D41AA SDI paddle board block diagram

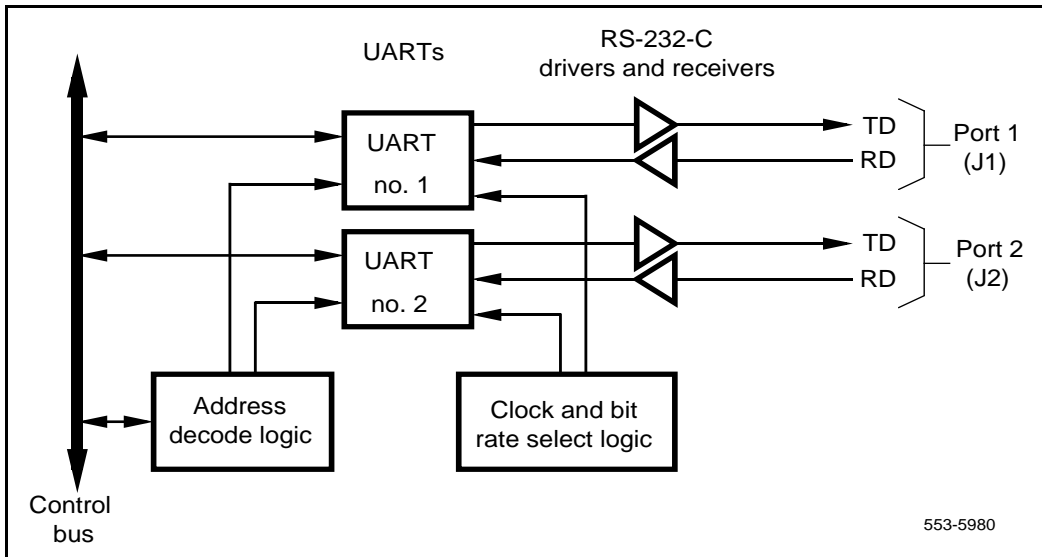

System considerations

In dual-processor Meridian 1 systems, the SDI paddle board will behave differently depending on which backplane socket it is installed in. Installing the paddle board into a socket in the network area of the backplane allows it to work when either of the system processors is active. Installing the paddle board into a socket in the CPU area of the backplane allows it to work only when that CPU is active.

The SDI paddle board is normally installed into a socket in the network area of the backplane. This allows it to be accessed by either of the system processors. This is necessary because the active CPU switches automatically each night at midnight, and whenever a fault occurs on the active CPU card.

The SDI paddle board can also be installed into a socket in the CPU area of the backplane. This is done when performing maintenance or an upgrade on the Meridian 1 system. The SDI paddle board is plugged into the CPU that is not the active system CPU. One of the serial ports on the SDI paddle board is then connected to a maintenance terminal and the CPU board is put into maintenance mode. Diagnostics can then be run from the maintenance terminal without having to stop the system. This is also used to perform a parallel reload of the system software without affecting the operation of the switch.

Connector pin assignments

The RS-232-C signals for port 1 are brought out on connector J1 and the RS-232-C signals for port 2 are brought out on connector J2. The pinouts of J1 and J2 are identical, so Table 4 can be used for both ports.

Table 4
Connectors J1 and J2 pin assignments

Pin #	Signal	Purpose in DTE mode	Purpose in DCE mode
1	CD	Carrier detect (Note 1)	Carrier detect (Not used)
2	RD	Transmitted data	Received data
3	TD	Received data	Transmitted data
4	DTR	Data terminal ready	Data terminal ready (Note 2)
5	GND	Ground	Ground
6	DSR	Data set ready (Note 1)	Data set ready
7	RTS	Request to send (Not Used)	Request to send (Note 2)
8	CTS	Clear to send (Note 1)	Clear to send

Note 1: In DTE mode the signals CD, DSR, and CTS are tied to +12 volts to signify that the port on the SDI paddle board is always ready to transmit and receive data.

Note 2: In DCE mode the signals DTR and RTS are tied to +12 volts to signify that the port on the SDI paddle board is always ready to transmit and receive data.

Configuring the SDI paddle board

Configuring the SDI paddle board to work in a Meridian 1 system consists of setting these option switches for each serial port:

- Port address
- Baud rate
- DTE/DCE/Fiber mode

The SDI paddle board has seven option switches, SW 2–8. Figure 3 on page 26 identifies the location of option switches on the SDI paddle board. Instructions for setting these switches are in the section that follows.

Once the board has been installed, the system software must be configured to recognize it. Instructions for doing this are found in ““Software service changes” on page 25”.

Option switch settings

Address

Address select switch SW4 and logic on the card always address the two UARTs using a pair of addresses: 0 and 1, 2 and 3 through 15 and 16. The settings for this switch are shown in Table 5.

Table 5
SDI paddle board address switch settings

Address		Switch SW4			
Port 1	Port 2	1	2	3	4
0	1	off	on	on	on
2	3	off	on	on	off
4	5	off	on	off	on
6	7	off	on	off	off
8	9	off	off	on	on
10	11	off	off	on	off
12	13	off	off	off	on
14	15	off	off	off	off

Baud rate

Switches SW2 and SW3 determine the baud rate for each individual port. The settings for these switches are shown in Table 6.

Table 6
SDI paddle board baud rate switch settings

Baud rate	Port 1 – SW2				Port 2 – SW3			
	1	2	3	4	1	2	3	4
150	off	off	on	on	off	off	on	on
300	off	on	off	on	off	on	off	on
600	off	off	off	on	off	off	off	on
1200	off	on	on	off	off	on	on	off
2400	off	off	on	off	off	off	on	off
4800	off	on	off	off	off	on	off	off
9600	off	off	off	off	off	off	off	off

DTE/DCE/Fiber mode

Each serial port can be configured to connect to a terminal (DTE equipment), a modem (DCE equipment), or a Fiber Superloop Network card. Instructions for setting the switches SW5, SW6, SW7, and SW8 are shown in Table 7 on page 25.

Table 7
NT8D41AA DTE/DCE/Fiber switch settings

Mode	Port 1 – SW5						Port 1 – SW6					
	1	2	3	4	5	6	1	2	3	4	5	6
DTE (terminal)	on	on	on	on	on	on	off	off	off	off	off	off
DCE (modem)	off	off	off	off	off	off	on	on	on	on	on	on
NT1P61 (Fiber)	on	on	on	on	off	off	off	off	on	on	on	on
	Port 2 – SW7						Port 2 – SW8					
DTE (terminal)	on	on	on	on	on	on	off	off	off	off	off	off
DCE (modem)	off	off	off	off	off	off	on	on	on	on	on	on
NT1P61 (Fiber)	on	on	on	on	off	off	off	off	on	on	on	on

Software service changes

Once the NT8D41 SDI paddle board has been installed in the system, the system software needs to be configured to recognize it. This is done using the Configuration Record program LD 17. Instructions for running the Configuration Record program are found in *Software Input/Output Guide Administration* (553-3001-311).

Figure 3
SDI paddle board option switch locations

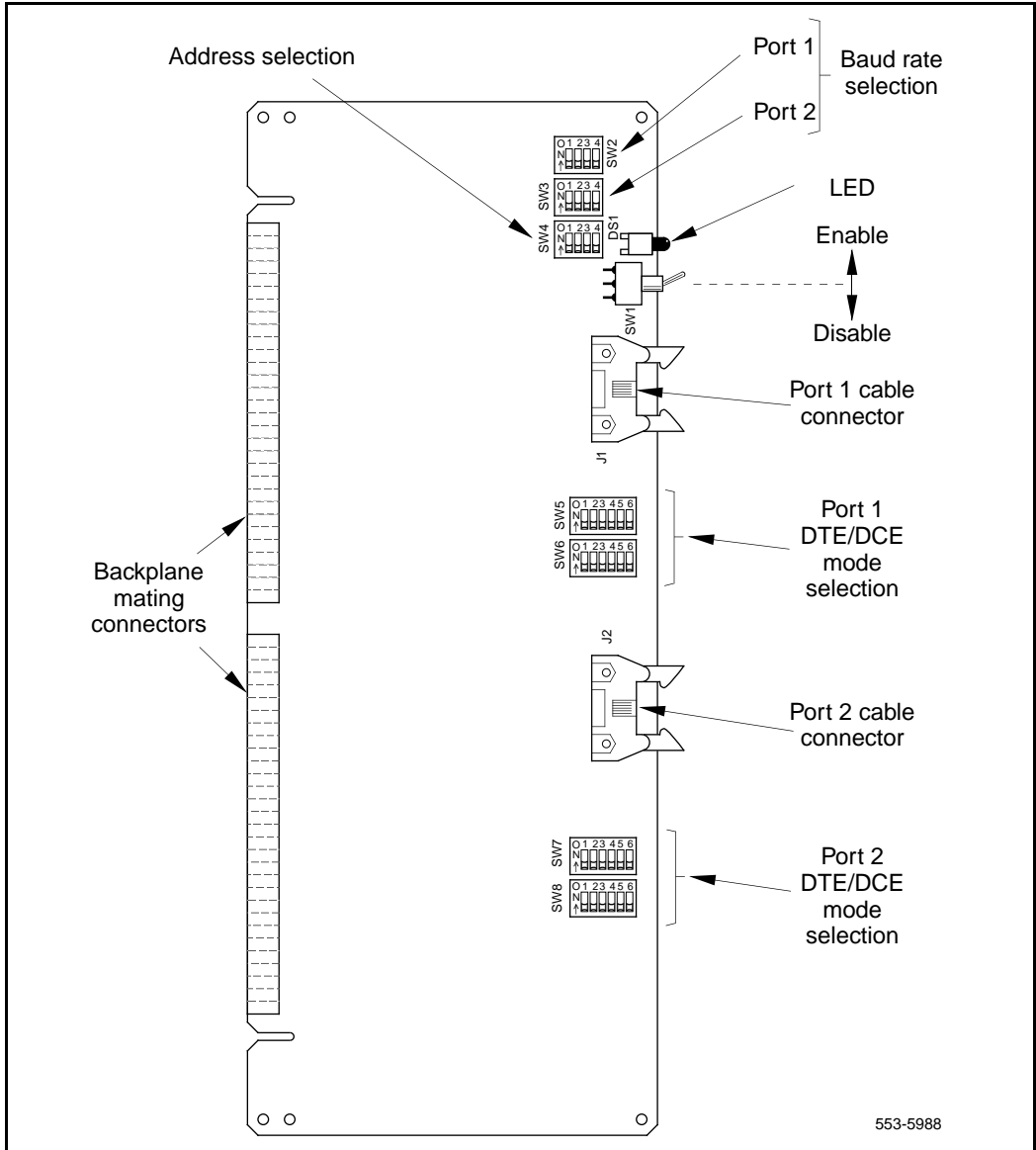

Some of the prompts that are commonly used when running the Configuration Record program LD 17, are shown in Table 8. These parameters must be set for each port if both ports are being used.

Table 8
Serial port configuration parameters

Prompt	Response	Description
REQ	CHG	Change configuration.
TYPE	CFN	Configuration type.
IOTB	YES	Change input/output devices.
ADAN	NEW TTY x New PRT x	Define a new system terminal (printer) port as device x, where x = 0 to 15.
CDNO	1–16	Use the SDI paddle board number to keep track of all ports.
DENS	DDEN	Double density SDI paddle board.
USER	xxx	Enter the user of port x. The values that can be entered depend on the software being used. See the <i>Software Input/Output Guide Administration (553-3001-311)</i> for details.
XSM	Yes, (No)	Port is used for the system monitor.

Applications

The NT8D41AA Serial Data Interface paddle board is used to connect the Meridian 1 switch to a variety of communications devices, printers, and peripherals. Any RS-232-C compatible device can be connected to either of the card's two serial ports.

The standard application for the paddle board is to connect the Meridian 1 switch to the system console. This can be either a direct connection if the console is located near the switch, or through a modem for remote maintenance.

Bell 103/212 compatible dumb modems are recommended to connect a remote data terminal. If a smart modem (such as a Hayes modem) is used, configure the modem for the dumb mode of operation (Command Recognition OFF, Command Echo OFF) before connecting the modem to the asynchronous port.

The serial data interface connectors on the paddle board are not RS-232-C standard DB-25 connectors. The NT8D84AA interface cable is used to adapt the paddle board to a non-standard pinout DB-9 connector (normally located on the I/O panel). The NT8D93 cable is then used to connect the non-standard DB-9 connector to a peripheral that uses a RS-232-C standard DB-25 connector. See Figure 4. on page 29

Figure 4
SDI paddle board cabling

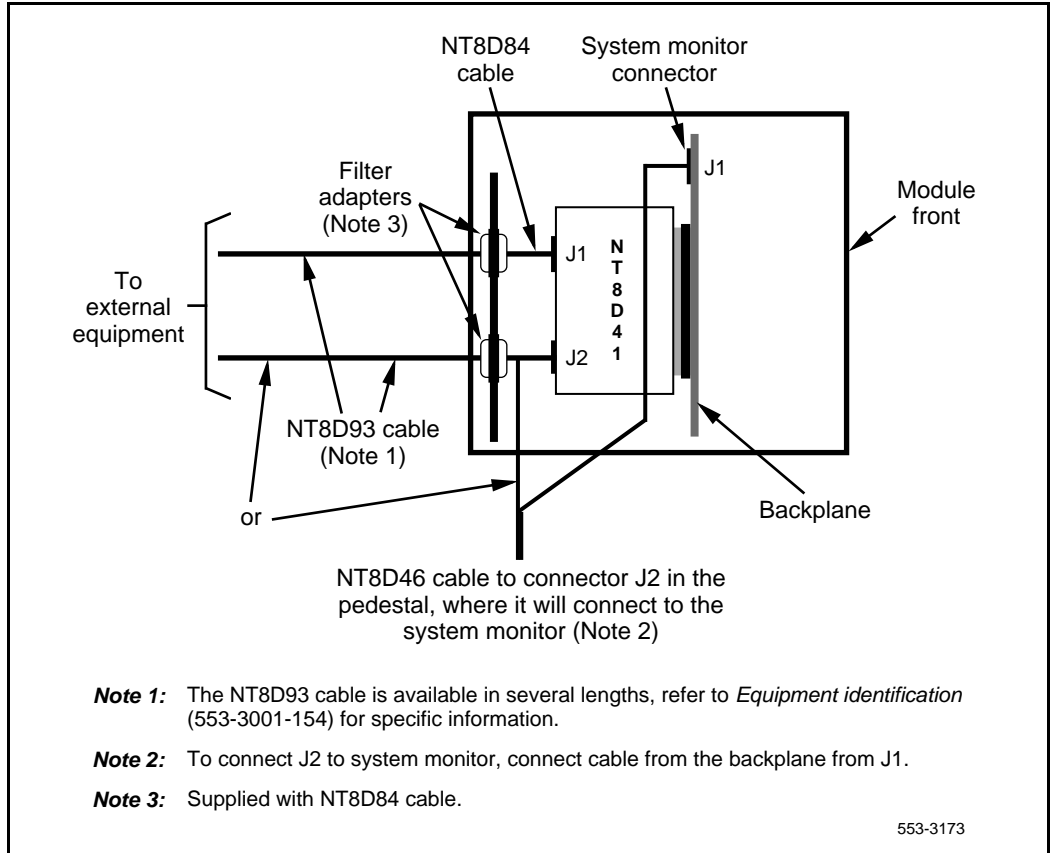

NT8D41BA Quad Serial Data Interface Paddle Board

Contents

This section contains information on the following topics:

Physical description.	32
Functional description.	34
System considerations.	35
Connector pin assignments.	36
Configuring the QSDI paddle board.	37
Option switch settings.	37
Software service changes.	40
Applications.	41

Reference list

The following are the references in this section:

- *Software Input/Output Guide Administration (553-3001-311)*

The NT8D41BA Quad Serial Data Interface (QSDI) paddle board provides four RS-232-C serial ports. These ports allow communication between the Meridian 1 system and four external devices, either DTE or DCE. The QSDI paddle board is normally used to connect the Meridian 1 system to the system administration and maintenance terminal. It can also be used to connect the system to a background terminal (used in the hotel/motel environment), a modem, or to the Automatic Call Distribution (ACD) or Call Detail Recording (CDR) features.

The QSDI paddle board mounts to a special socket on the rear of the backplane of the following modules:

- NT5D21 Core/Network Module for system Options 51C, 61C, and 81C
- NT6D39 CPU/Network Module for system Options 51 and 61
- NT9D11 Core/Network Module for system Option 61C

The QSDI paddle board is compatible with all existing system software, but can only be used with the Meridian 1 system options listed above. It does not support the 110 baud rate or the 20 mA current loop interface.

Physical description

The NT8D41BA Quad Serial Data Interface paddle board is a printed circuit board measuring 31.12 by 12.7 cm (12.25 by 5.0 in.). See Figure 5 on page 33.

The QSDI paddle board can be used in a system backplane for a total of four serial ports. Up to 12 other serial ports can be added by plugging standard serial cards into standard system slots. The serial ports on the card are addressed as a pair of consecutive addresses (0 and 1, 2 and 3, up to 14 and 15), using switches SW15 and SW16.

The front edge of the card has four serial port connectors, an Enable/Disable switch (ENB/DIS), and a red LED. The LED indicates the card status. It is lit when the following occurs:

- the ENB/DIS switch is set to disable
- all four ports are disabled in software
- all four ports are not configured in the configuration record

Figure 5
NT8D41BA QSDI paddle board

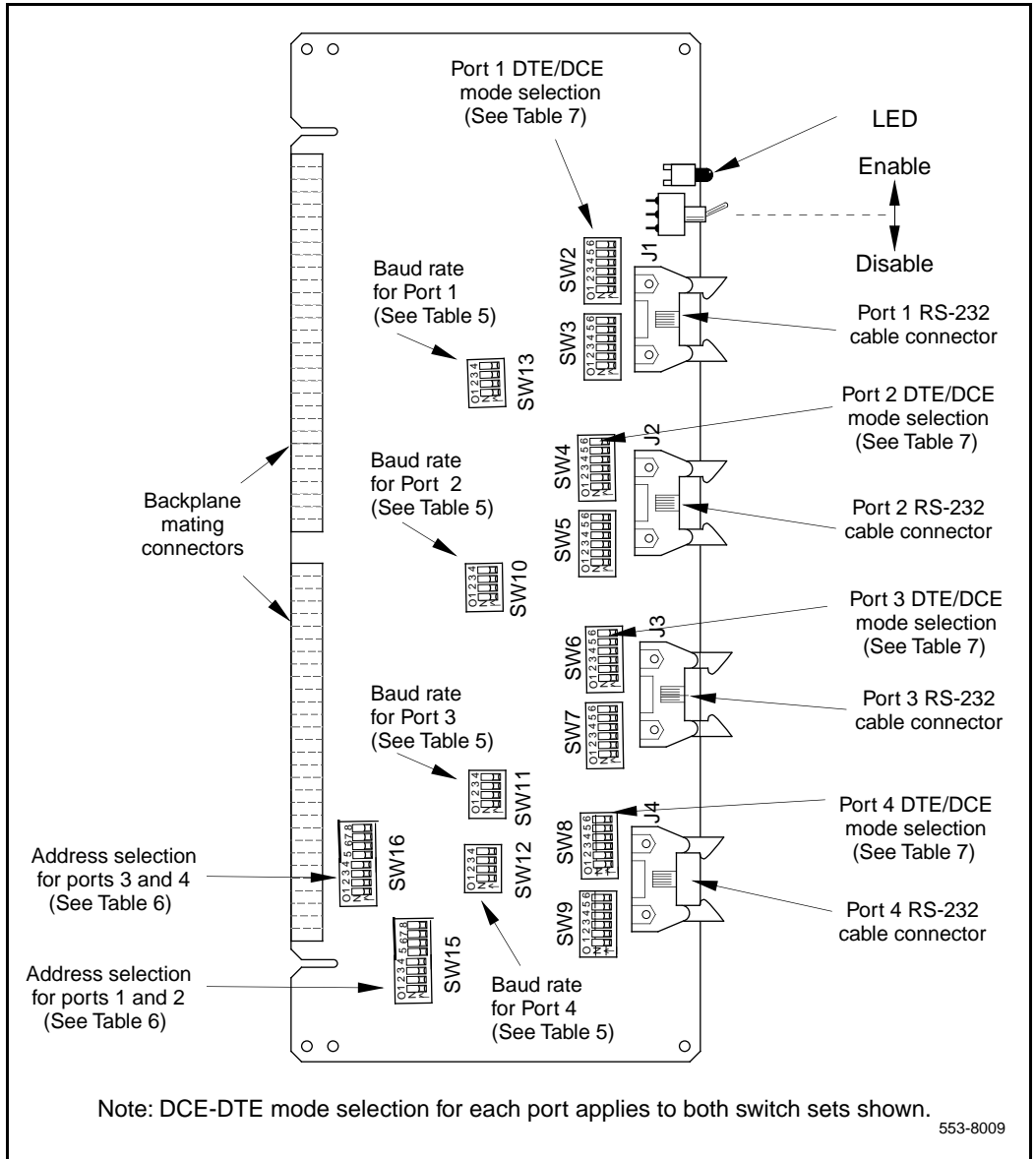

Functional description

The NT8D41BA QSDI paddle board has four asynchronous serial ports. These serial ports are connected to the I/O panel in the back of the shelf using special adapter cables. The serial ports can be used to connect the Meridian 1 system to a terminal, a printer, a modem, or to an other system processor.

The QSDI paddle board design contains four Universal Asynchronous Receiver/Transmitters (UARTs) and the logic necessary to connect the UARTs to the system processor bus. See Figure 6. Other logic on the card includes baud rate generators, RS-232-C driver/receiver pairs, and the switches and logic needed to configure each UART.

Figure 6
NT8D41BA QSDI paddle board block diagram

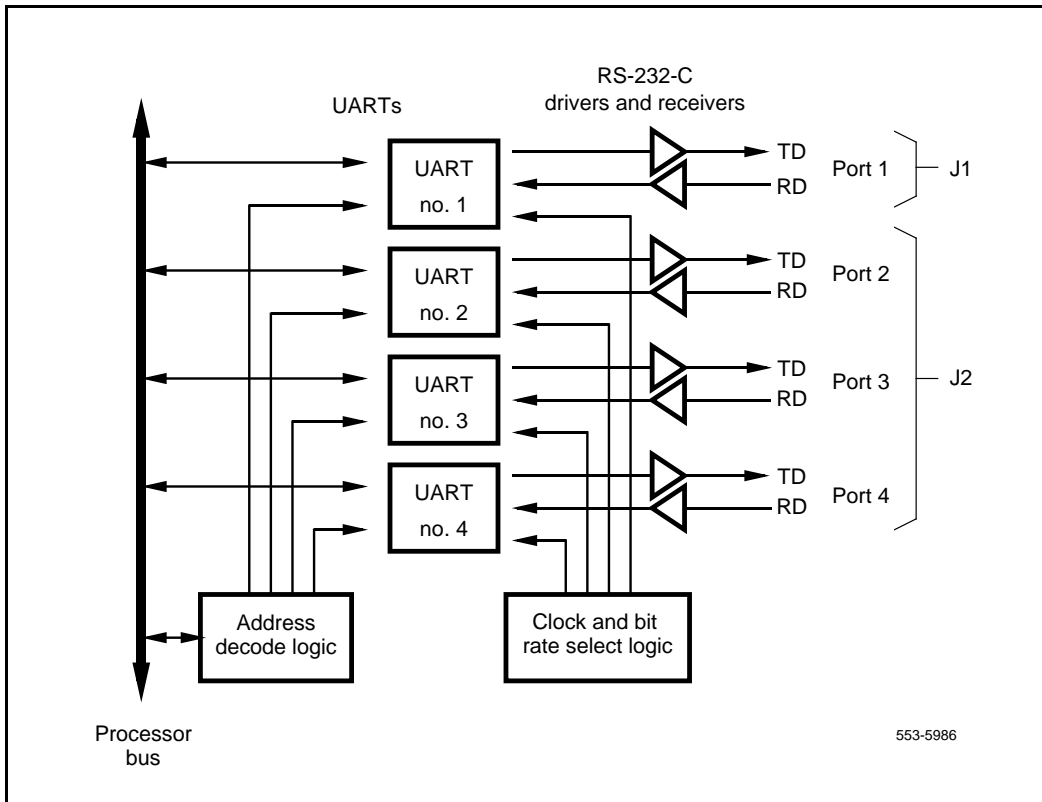

553-5986

System considerations

In dual-processor Meridian 1 systems, the QSDI paddle board will behave differently depending on which backplane socket it is installed. Installing the paddle board into a socket in the network area of the backplane allows it to work when either of the system processors is active. Installing the paddle board into a socket in the CPU area of the backplane allows it to work only when that CPU is active.

The QSDI paddle board is normally installed into a socket in the network area of the backplane. This allows it to be accessed by either of the system processors. This is necessary because the active CPU switches automatically each night at midnight and whenever a fault occurs on the active CPU card.

The QSDI paddle board can also be installed into a socket in the CPU area of the backplane (supported in NT6D39AA shelves only). This is done when performing maintenance or an upgrade on the Meridian 1 system.

The QSDI paddle board is plugged into the CPU that is not the active system CPU. One of the serial ports on the QSDI paddle board is then connected to a maintenance terminal and the CPU board is put into maintenance mode. Diagnostics can then be run from the maintenance terminal without having to stop the system. This is also used to perform a parallel reload of the system software without affecting the operation of the switch.

Connector pin assignments

The RS-232-C signals for port 1 through port 4 are brought out on connector J1 through J4 respectively. The pinouts for each port are identical to those for each of the other three ports. Table 9 shows the pin assignment that applies to each connector.

Table 9
Connectors J1, J2, J3, and J4 pin assignments

Pin #	Signal	Purpose in DTE mode	Purpose in DCE mode
1	DCD	Data Carrier detect (Note 1)	Data Carrier detect (Not used)
2	RD	Transmitted data	Received data
3	TD	Received data	Transmitted data
4	DTR	Data terminal ready	Data terminal ready (Note 2)
5	GND	Signal Ground	Signal Ground
6	DSR	Data set ready (Note 1)	Data set ready
7	RTS	Request to send (Not Used)	Request to send (Note 2)
8	CTS	Clear to send (Note 1)	Clear to send

Note 1: In DTE mode the signals CD, DSR, and CTS are tied to +12 volts to signify that the port on the QSDI paddle board is always ready to transmit and receive data. This mode is set to connect to a terminal device (DTE).

Note 2: In DCE mode the signals DTR and RTS are tied to +12 volts to signify that the port on the QSDI paddle board is always ready to transmit and receive data. This mode is set to connect to a modem device (DCE).

Configuring the QSDI paddle board

Configuring the QSDI paddle board to work in a Meridian 1 system consists of setting these option switches for each serial port:

- Baud rate
- Port address
- DTE/DCE mode

The QSDI paddle board has fourteen option switches, SW2–13, SW15-16. Figure 5 on page 33 identifies the location of option switches on the QSDI paddle board. Learn how to set these switches in the following sections.

Once the board has been installed, the system software must be configured to recognize it. Instructions for doing this are found in the section titled “Software service changes” on page 40.

Option switch settings

Baud rate

Switches SW13, SW10, SW11, and SW12 determine the baud rate for ports 1, 2, 3, and 4, respectively. See the settings for these switches in Table 10.

Table 10
NT8D41BA baud rate switch settings

Baud rate	Baud Clock (kHz)	SW13 (port 1), SW10 (port 2), SW11 (port 3), SW12 (port 4)			
		1	2	3	4
150	2.40	on	off	on	on
300	4.80	on	on	off	on
600	9.60	on	off	off	on
1,200	19.20	on	on	on	off
2,400	38.40	on	off	on	off
4,800	76.80	on	on	off	off
9,600	153.60	on	off	off	off
19,200*	307.20	on	on	on	on

* For future use.

Address

Switch SW15 or SW16 and logic on the card always address the four UARTs using a pair of addresses: 0 and 1, 2 and 3 through 14 and 15. The settings for both switches are shown in Table 11. To avoid system problems, switches SW15 and SW16 must not be configured identically. Figure 5 on page 33 displays SW15 and SW16.

Table 11
NT8D41BA address switch settings

SW15	Port 1	Port 2	Switch settings							
SW16	Port 3	Port 4	1*	2*	3	4	5	6	7	8
Device pair addresses	0	1	E	X	off	off	off	off	off	off
	2	3	E	X	off	off	off	off	off	on
	4	5	E	X	off	off	off	off	on	off
	6	7	E	X	off	off	off	off	on	on
	8	9	E	X	off	off	off	on	off	off
	10	11	E	X	off	off	off	on	off	on
	12	13	E	X	off	off	off	on	on	off
	14	15	E	X	off	off	off	on	on	on

* To enable ports 1 and 2, set SW15 position 1 to ON. To enable ports 3 and 4, set SW16 position 1 to ON.

+ For each X, the setting for this switch makes no difference, because it is not used.

DTE/DCE/Fiber mode

Each serial port can be configured to connect to a terminal (DTE equipment), a modem (DCE equipment), or a Fiber Superloop Network card. Instructions for setting the switches SW2, SW3, SW4, SW5, SW6, SW7, SW8, and SW9 are shown in Table 12. Figure 5 on page 33 shows the location of these switches on the paddleboard.

Table 12
NT8D41BA DTE/DCE/Fiber switch settings

Mode	Port 1 — SW 3						Port 1 — SW 2					
	1	2	3	4	5	6	1	2	3	4	5	6
DTE (terminal)	on	on	on	off	on	off	off	on	off	on	off	on
DCE (modem)	off	off	off	on	off	on	on	off	on	off	on	off
NT1P61 (Fiber)	on	on	on	on	on	off	on	on	on	off	on	off
	Port 2 — SW 5						Port 2 — SW 4					
DTE (terminal)	on	on	on	off	on	off	off	on	off	on	off	on
DCE (modem)	off	off	off	on	off	on	on	off	on	off	on	off
NT1P61 (Fiber)	on	on	on	on	on	off	on	on	on	off	on	off
	Port 3 — SW 7						Port 3 — SW 6					
DTE (terminal)	on	on	on	off	on	off	off	on	off	on	off	on
DCE (modem)	off	off	off	on	off	on	on	off	on	off	on	off
NT1P61 (Fiber)	on	on	on	on	on	off	on	on	on	off	on	off
	Port 4 — SW 9						Port 4 — SW 8					
DTE (terminal)	on	on	on	off	on	off	off	on	off	on	off	on
DCE (modem)	off	off	off	on	off	on	on	off	on	off	on	off
NT1P61 (Fiber)	on	on	on	on	on	off	on	on	on	off	on	off

Software service changes

Once the NT8D841BA QSDI paddle board has been installed in the system, the system software needs to be configured to recognize it, using the Configuration Record program LD 17. Instructions for running this program are found in *Software Input/Output Guide Administration* (553-3001-311).

Some of the prompts that are commonly used when running the Configuration Record program LD 17 are shown in Table 13. These parameters must be set for each port if both ports are being used.

LD 17 – Prompts to configure the NT8D841Ba paddle board.

Prompt	Response	Description
REQ	CHG	Change configuration.
TYPE	ADAN	Configuration type.
ADAN	NEW TTY x New PRT x	Define a new system terminal (printer) port as device x, where x = 0 to 15.
CTYPE	SDI4	Quad port card
DES	XQSDI	Quad density QSDI paddle board.
USER	xxx	Enter the user of port x. The values that can be entered depend on the software being used. See the <i>Software Input/Output Guide Administration</i> (553-3001-311) for details.
XSM	Yes, (No)	Port is used for the system monitor.

Applications

The NT8D41BA Quad Serial Data Interface paddle board is used to connect the Meridian 1 switch to a variety of communications devices, printers, and peripherals. Any RS-232-C compatible device can be connected to either of the card's two serial ports.

The standard application for the paddle board is to connect the Meridian 1 switch to the system console. This can be either a direct connection if the console is located near the switch, or through a modem for remote maintenance.

Bell 103/212 compatible dumb modems are recommended to connect a remote data terminal. If a smart modem (such as a Hayes modem) is used, configure the modem for the dumb mode of operation (Command Recognition OFF, Command Echo OFF) before connecting the modem to the asynchronous port.

The serial data interface connectors on the paddle board are not RS-232-C standard DB-25 connectors. The NT8D84AA interface cable is used to adapt the paddle board to a non-standard pinout DB-9 connector (normally located on the I/O panel). The NT8D93 cable is then used to connect the non-standard DB-9 connector to a peripheral that uses a RS-232-C standard DB-25 connector. See Figure 7 on page 42.

Figure 7
NT8D41BA QSDI paddle board cabling

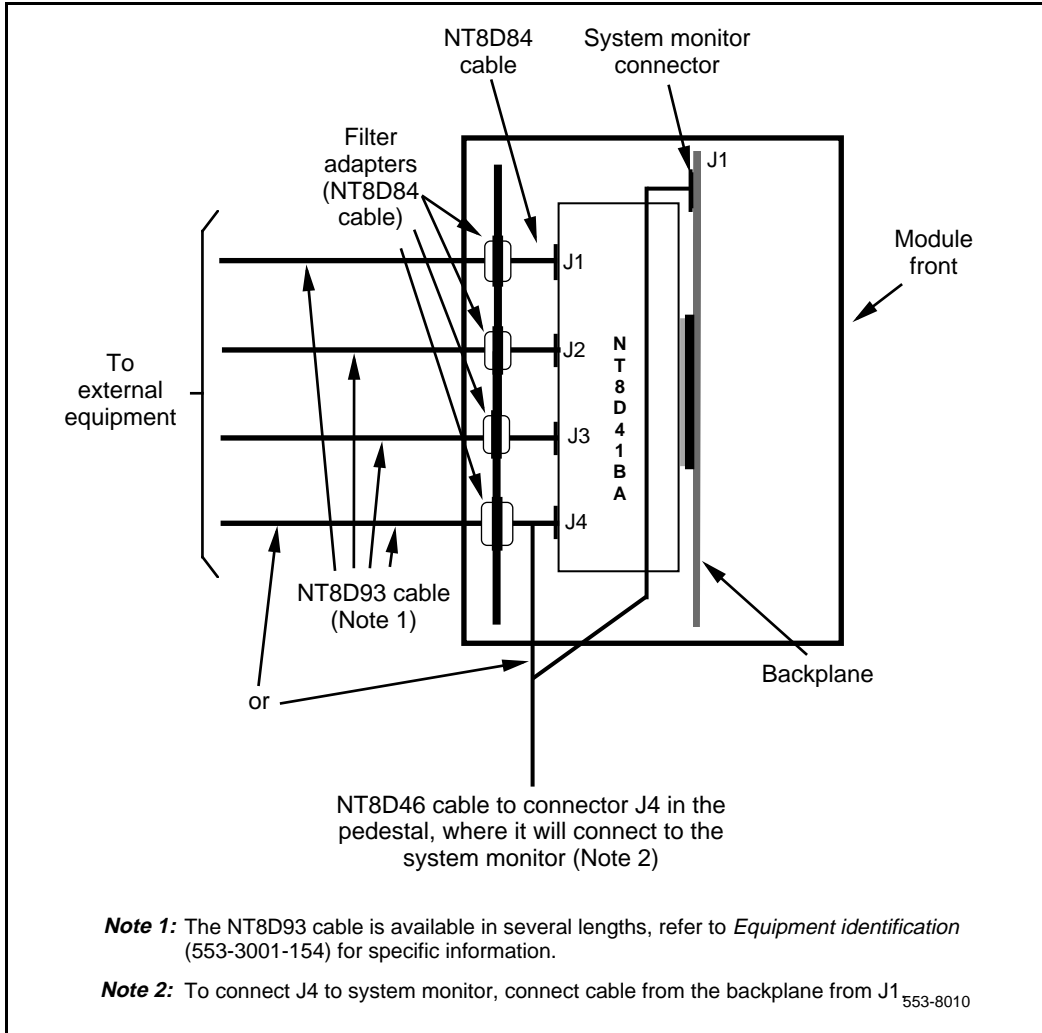

QPC841 Quad Serial Data Interface Card

Contents

This section contains information on the following topics:

Physical description.	44
Functional description.	45
Connector pin assignments.	48
Configuring the QSDI card.	50
Software service changes.	54
Applications.	55

Reference list

The following are the references in this section:

- *Software Input/Output Guide Administration* (553-3001-311)
- *Equipment Identification* (553-3001-154)

The QPC841 Quad Serial Data Interface (QSDI) Card provides four RS-232-C serial ports between the Meridian 1 system and external devices. The QSDI card plugs into a slot in the common equipment area of any Meridian 1 system.

The Quad Serial Data Interface Card is normally used to connect the Meridian 1 system to its administration and maintenance terminal. It is also used to connect the system to a background terminal (used in the Hotel/Motel environment), a modem, or the Automatic Call Distribution (ACD) and Call Detail Recording (CDR) features.

The QSDI Card is compatible with all existing system software. It does not support 20 mA current loop interface.

QSDI cards are housed in the following modules:

- NT5D21 Core/Network Module (slots 0 through 7) for system Options 51C, 61C, and 81C
- NT6D39 CPU/Network Module (slots 1 through 9, and 13) for system Options 51 and 61
- NT6D60 Core Module (slots 0 through 5) for system Option 81
- NT8D11 Common /Peripheral Equipment (CE/PE) Module (“NET” slots 4 through 9) for system Options 21, 21A, and 21E
- NT8D34 CPU Module (slots 6 and 13) for system Option 71
- NT8D35 Network Module (slots 5 through 13) in active network groups for system Options 71 and 81
- NT9D11 Core/Network Module (slots 0 through 8) for system Option 61C

Note: When a QSDI card is installed in an NT6D60 Core Module, an NT8D34 CPU Module, or slot 13 of an NT6D39 CPU/Network Module in a dual-CPU system, any input/output I/O device connected to the card does not function when the CPU in that module is inactive.

Physical description

The QPC841 QSDI Card is a printed circuit board measuring 31.75 cm by 25.4 cm (12.5 in. by 10 in.). The front panel is 2.54 cm (1 in.) thick. See Figure 8 on page 46.

Up to four QSDI boards can be used in a system, allowing a total of sixteen asynchronous serial ports. The four serial ports on each card are addressed as two pairs of consecutive addresses (0 and 1, 2 and 3, and so on up to 14 and 15). The pairs need not be consecutive. For example: pairs 0 and 1, and 4 and 5 could be used.

The card front panel has two connectors, J1 and J2. Connector J1 is used for port 1 while connector J2 is used for ports 2, 3, and 4. It also has an Enable/Disable (ENB/DIS) switch and a red LED. The LED indicates that the card has been disabled. It is lit when the following occurs:

- the ENB/DIS switch is set to DIS
- all of the ports on the card are disabled in software
- none of the card ports are configured in software

Functional description

The QPC841 Quad Serial Data Interface Card contains all the logic for four asynchronous serial ports, including the baud rate generators. These serial ports are directly accessed by the system processor using memory reads and writes.

The QPC841 Quad Serial Data Interface Card contains four universal asynchronous receiver/transmitters (UARTs) and the logic necessary to connect the UARTs to the system processor bus. See Figure 9 on page 47. The other logic on the card consists of four baud rate generators, four RS-232-C driver/receiver pairs, and the jumpers and logic needed to configure the UARTs.

The address select switches and logic on the card always address the UARTs using two pairs of addresses: 0 and 1, and 2 and 3 through 15 and 16. The pairs do not need to be consecutive. Other switches on the board determine the baud rate for each individual port and whether the port is configured to talk to a terminal (DTE equipment) or a modem (DCE equipment). Instructions for setting the jumpers are given later in this section.

Figure 8
QPC841 QSDI Card front panel

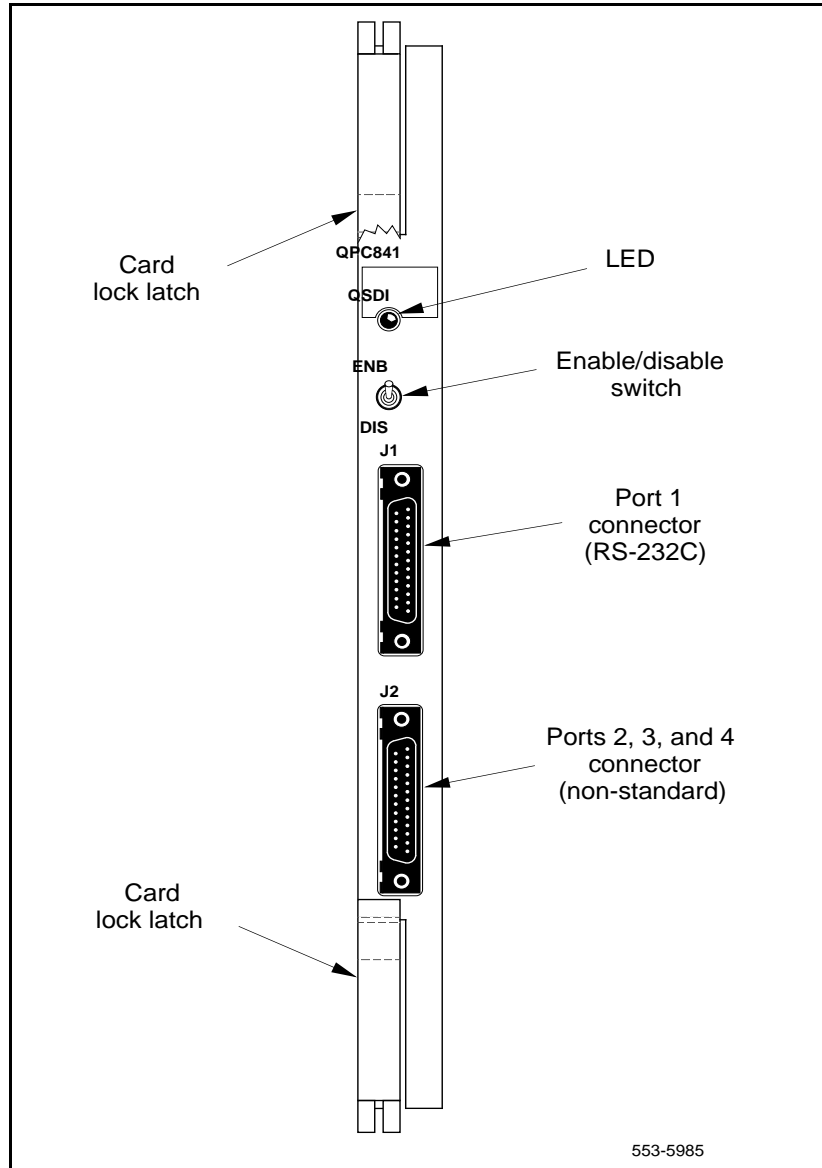
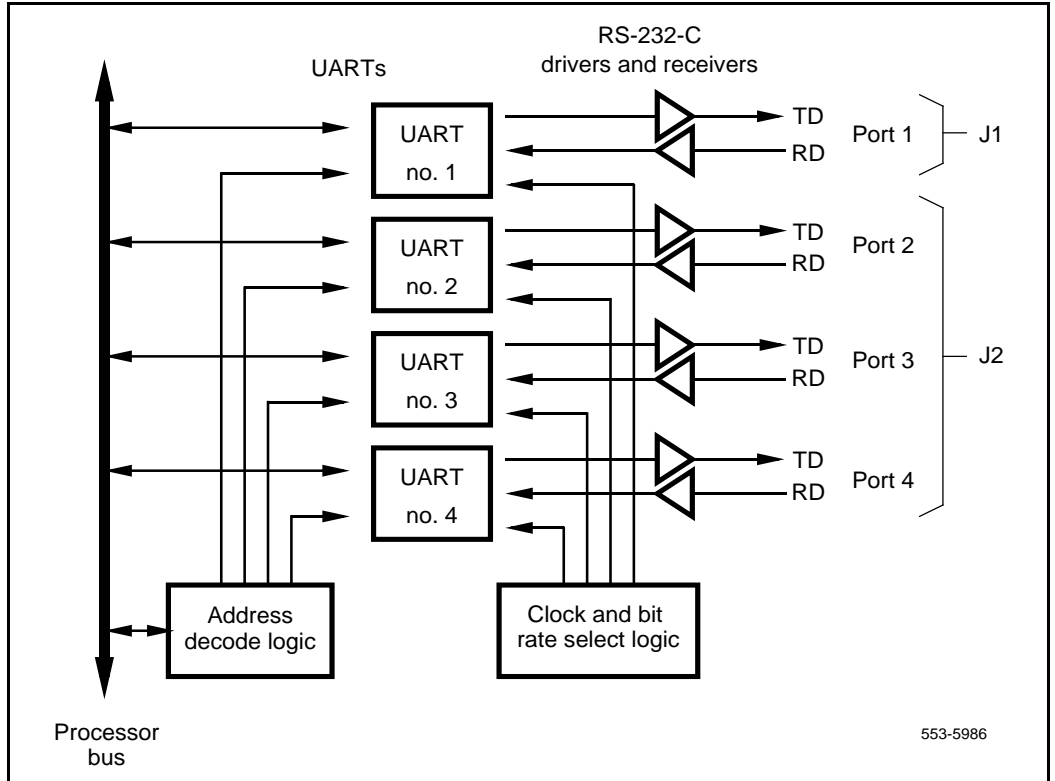

Figure 9
QPC841 QSDI Card block diagram



Connector pin assignments

Connector J1 is connected to port one, and uses the RS-232-C standard DB-25 pinout. Connector J2 is connected to ports two, three, and four, and is a non-standard pinout that requires an adapter cable. An adapter cable (NT8D96) splits the J2 signals out to three standard RS-232-C connectors. Port 2 is connected to connector A, Port 3 is connected to connector B, and Port 4 is connected to connector C.

Table 14 shows the pinouts for connector J1, and Table 15 on page 49 shows the pinouts for connector J2.

Table 14
Connector J1 pin assignments

Pin number	Signal	Purpose in DTE mode	Purpose in DCE mode
1	FGD	Frame ground	Frame ground
2	TD	Received data	Transmitted data
3	RD	Transmitted data	Received data
4	RTS	Request to send (not used)	Request to send (Note 2)
5	CTS	Clear to send (Note 1)	Clear to send
6	DSR	Data set ready (Note 1)	Data set ready
7	GND	Ground	Ground
8	CD	Carrier detect (Note 1)	Carrier detect (not used)
20	DTR	Data terminal ready	Data terminal ready (Note 2)

Note 1: In DTE mode, the signals CD, DSR, and CTS are tied to +12 volts (through a resistor) to indicate that the QSDI port is always ready to transmit and receive data.

Note 2: In DCE mode, the signals DTR, and RTS are tied to +12 volts (through a resistor) to indicate that the QSDI port is always ready to transmit and receive data.

Table 15
Connector J2 pin assignments

Pin Number	Port	Signal	Purpose in DTE mode	Purpose in DCE mode
1	2	FGD	Frame ground	Frame ground
2		TD	Transmitted data	Transmitted data
3		RD	Received data	Received data
4		RTS	Request to send (not used)	Request to send (Note 2)
5		CTS	Clear to send (Note 1)	Clear to send
6		DSR	Data set ready (Note 1)	Data set ready
7		GND	Ground	Ground
8		CD	Carrier detect (Note 1)	Carrier detect (not Used)
20	3	DTR	Data terminal ready	Data terminal ready (Note 2))
9		TD	Transmitted data	Transmitted data
10		RD	Received data	Received data
11		RTS	Request to send (not used)	Request to send (Note 2))
12		CTS	Clear to send (Note 1)	Clear to send
13		DSR	Data set ready (Note 1)	Data set ready
25		GND	Ground	Ground
24		CD	Carrier detect (Note 1)	Carrier detect (not used)
23	4	DTR	Data terminal ready	Data terminal ready (Note 2))
14		TD	Transmitted data	Transmitted data
15		RD	Received data	Received data
16		RTS	Request to send (not used)	Request to send (Note 2))
17		CTS	Clear to send (Note 1)	Clear to send
18		DSR	Data set ready (Note 1)	Data set ready
19		GND	Ground	Ground
21		CD	Carrier detect (Note 1)	Carrier detect (not used)
22		DTR	Data terminal ready	Data terminal ready (Note 2))

Note 1: In DTE mode, the signals CD, DSR, and CTS are tied to +12 volts (through a resistor) to indicate that the QSDI port is always ready to transmit and receive data.

Note 2: In DCE mode, the signals DTR and RTS are tied to +12 volts (through a resistor) to indicate that the QSDI port is always ready to transmit and receive data.

Configuring the QSDI card

Configuring the QSDI card to work in a Meridian 1 system consists of setting these option switches for each serial port:

- Port address
- Baud rate
- DTE/DCE mode

Figure 10 on page 53 shows the location of the option switches on the QSDI card. Instructions for setting these switches are in the section that follows.

Address switch settings

Table 16 lists the address switch settings for the QPC841 Quad Serial Data Interface Card. The address select jumpers and logic on the card address the UARTs using two pairs of addresses: 0 and 1, 2 and 3, through 15 and 16. The pairs do not need to be consecutive. Switch SW14 is used to select the addresses for ports 1 and 2. Switch SW15 is used to select the addresses for ports 3 and 4.

Table 16
QSDI card address switch settings

SW14	Port 1	Port 2	Switch settings							
SW15	Port 3	Port 4	1	2	3	4	5	6	7	8
Device pair addresses	0	1	off	off	off	off	off	on	on	on
	2	3	off	off	off	off	off	on	on	off
	4	5	off	off	off	off	off	on	off	on
	6	7	off	off	off	off	off	on	off	off
	8	9	off	off	off	off	off	off	on	on
	10	11	off	off	off	off	off	off	on	off
	12	13	off	off	off	off	off	off	off	on
	14	15	off	off	off	off	off	off	off	off

Note 1: On SW16, positions 1, 2, 3, and 4 must be OFF.

Note 2: To avoid address conflicts, SW14 and SW15 can never have identical settings.

Note 3: To disable ports 1 and 2, set SW14 position 1 to ON. To disable ports 3 and 4, set SW15 position 1 to ON.

Baud rate switch settings

Table 17 lists the switch settings necessary to set the baud rate.

Table 17
QSDI card baud rate switch settings

Baud rate	Port 1 – SW10				Port 2 – SW11				Port 3 – SW12				Port 4 – SW13			
	1	2	3	4	1	2	3	4	1	2	3	4	1	2	3	4
150	off	off	on	on	off	off	on	on	off	off	on	on	off	off	on	on
300	off	on	off	on	off	on	off	on	off	on	off	on	off	on	off	on
600	off	off	off	on	off	off	off	on	off	off	off	on	off	off	off	on
1200	off	on	on	off	off	on	on	off	off	on	on	off	off	on	on	off
2400	off	off	on	off	off	off	on	off	off	off	on	off	off	off	on	off
4800	off	on	off	off	off	on	off	off	off	on	off	off	off	on	off	off
9600	off	off	off	off	off	off	off	off	off	off	off	off	off	off	off	off

DTE/DCE mode switch settings

Table 18 shows the DTE/DCE mode selection switches for the four serial ports.

Table 18
QSDI card DTE/DCE mode switch settings

Mode	Port 1 – SW8						Port1 – SW9					
	1	2	3	4	5	6	1	2	3	4	5	6
DTE (Terminal)	on	on	on	on	on	on	off	off	off	off	off	off
DCE (Modem)	off	off	off	off	off	off	on	on	on	on	on	on
	Port 2 – SW6						Port 2 – SW7					
DTE (Terminal)	on	on	on	on	on	on	off	off	off	off	off	off
DCE (Modem)	off	off	off	off	off	off	on	on	on	on	on	on
	Port 3 – SW4						Port 3 – SW5					
DTE (Terminal)	on	on	on	on	on	on	off	off	off	off	off	off
DCE (Modem)	off	off	off	off	off	off	on	on	on	on	on	on
	Port 4 – SW2						Port 4 – SW3					
DTE (Terminal)	on	on	on	on	on	on	off	off	off	off	off	off
DCE (Modem)	off	off	off	off	off	off	on	on	on	on	on	on

Test switch setting

Switch SW16 is only used for factory testing; all of its switches must be set to OFF for proper operation.

Figure 10
QSDI card option switch locations

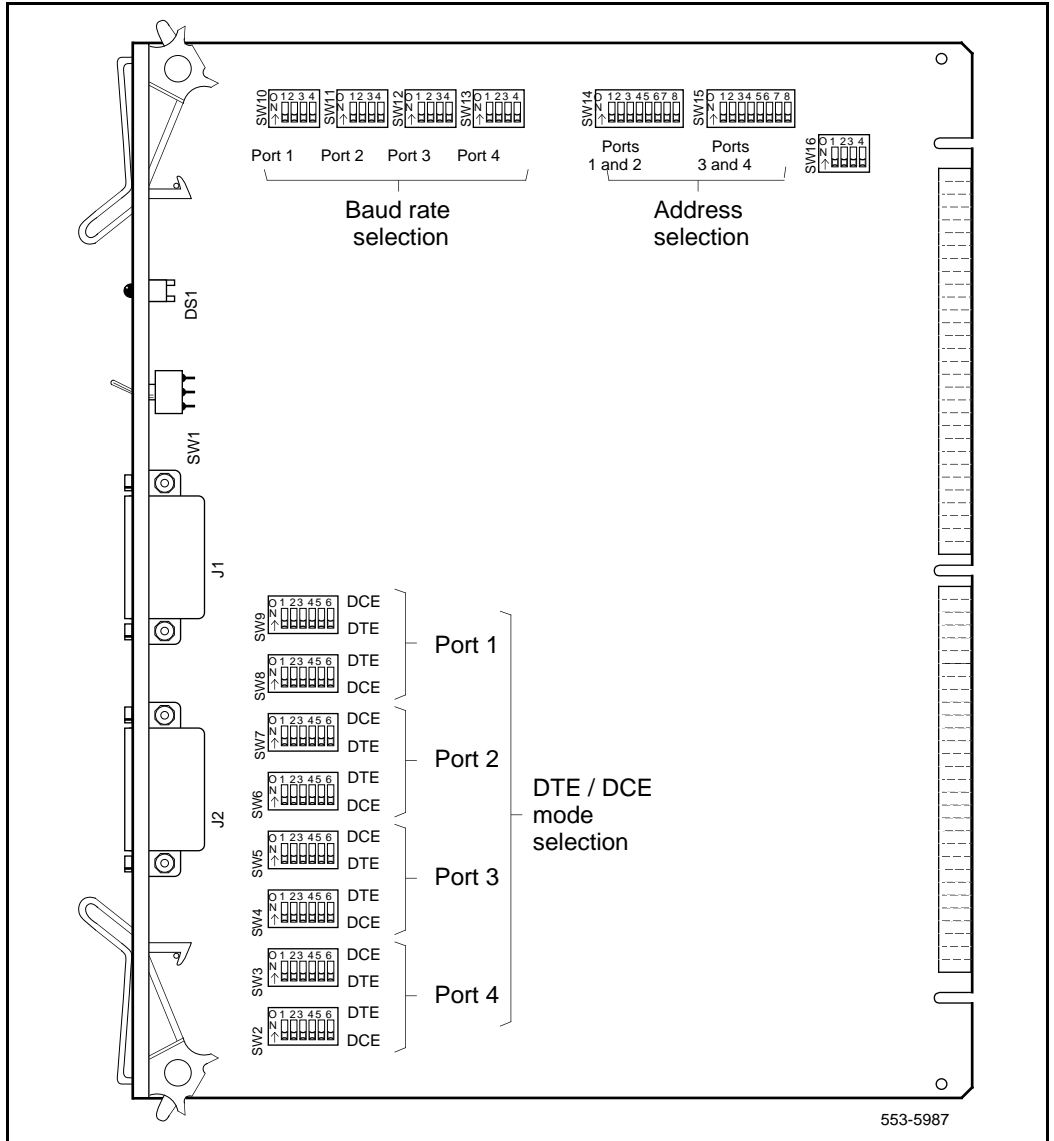

Software service changes

Once the QPC841 QSDI card has been installed in the system, the system software needs to be configured to recognize it. This is done using the Configuration Record program LD 17. Instructions for running the Configuration Record program are found in *Software Input/Output Guide Administration* (553-3001-311).

Some of the prompts that are commonly used when running the Configuration Record program LD 17 are shown in Table 19. These parameters must be set for each port that is being used.

LD 17 – Serial port configuration parameters.

Prompt	Response	Description
REQ	CHG	Change configuration.
TYPE	CFN	Configuration type.
IOTB	YES	Change input/output devices.
ADAN	NEW TTY x New PRT x	Define a new system terminal (printer) port as device x, where x = 0 to 15.
CDNO	1–16	Use the QSDI card number to keep track of all ports.
DENS	DDEN	Double density SDI paddle board.
USER	xxx	Enter the user of port x. The values that can be entered depend on the software being used. See <i>Software Input/Output Guide Administration</i> (553-3001-311) for details.
XSM	Yes, (No)	Port is used for the system monitor.

Applications

The QPD841 Quad Serial Data Interface (QSDI) card is used to connect the Meridian 1 switch to a variety of communications devices and peripherals. Any RS-232-C compatible device can be connected to any of the four serial ports.

The standard application for the QSDI card is to connect the Meridian 1 switch to the system console. This can be either a direct connection if the console is located near the switch, or through a modem for remote maintenance.

Bell 103/212 compatible dumb modems are recommended to connect a remote data terminal. If a smart modem (such as a Hayes modem) is used, select the dumb mode of operation (Command Recognition OFF, Command Echo OFF) before connecting the modem to the asynchronous port.

Serial data interface connector J1 is a standard RS-232-C DB-25 connector that connects port 1 of the QSDI card to outside peripherals. Connector J2 is non-standard in that it contains the connections for the three remaining serial ports (ports 2, 3, and 4), on a single DB-25 connector. An adapter cable must be used to connect to standard RS-232-C peripherals. Cables that are applicable to the QSDI card are

- SDI male-to-female flat cables (internal module use only)
 - NT8D82
 - QCAD290

Note: This cable is available in different lengths. Refer to the *Equipment Identification* (553-3001-154) for more information

- QCAD42
- SDI male-to-male round cables (external use only)
 - NT8D95
- SDI to I/O cables (system options use only)
 - NT8D82

Note: This cable is available in different lengths. Refer to *Equipment Identification* (553-3001-154) for more information

- SDI multiple-port cable (internal system options use only)
 - NT8D90
- SDI I/O to DTE/DCE cables (system options use only)
 - NT8D95

Note: This cable is available in different lengths. Refer to *Equipment Identification* (553-3001-154) for more information

- SID Multiple-port cable (system options use only)
 - NT8D96

Figure 11 shows the QPC841 card and the cables listed above in a standard configuration:

Figure 11
QPC841 QSDI Card cabling

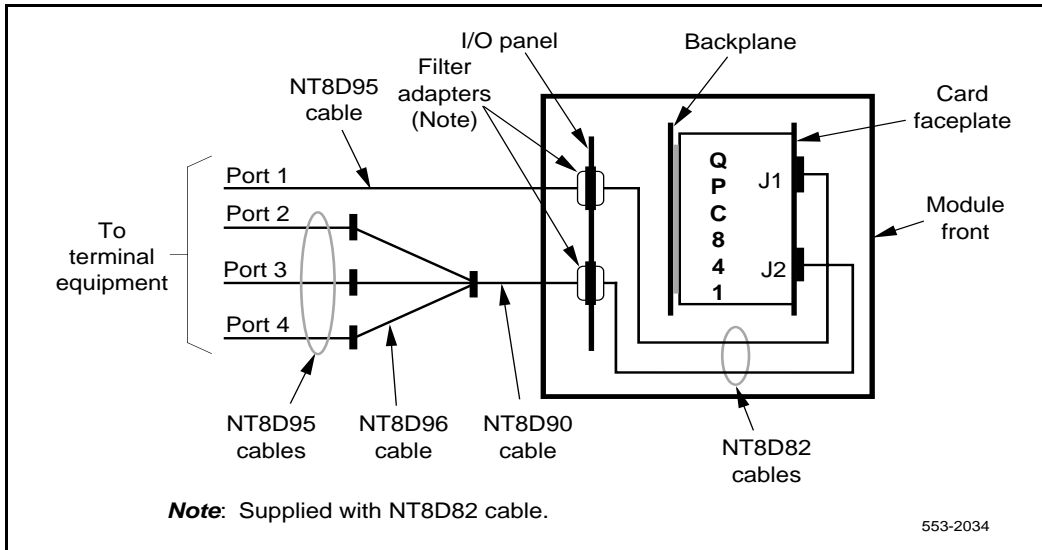

553-2034

QPC513 Enhanced Serial Data Interface Card

Contents

This section contains information on the following topics:

Physical description.	59
Functional description.	61
Synchronous communications.	62
Clock timing option.	63
Test and maintenance features.	64
Connection characteristics.	65
Connector pin assignments.	67
Configuring the ESDI card.	69
Address switch settings.	69
DTE/DCE mode jumper settings.	72
Software service changes.	73
Applications.	74

Reference list

The following are the references in this section:

- *Software Input/Output Guide Administration* (553-3001-311)

The QPC513 Enhanced Serial Data Interface (ESDI) Card gives the Meridian 1 switch two fully synchronous high-speed serial ports.

These high-speed synchronous ports are used to connect the Meridian processor to synchronous communication peripherals such as Meridian Mail or to a host computer (for example, DEC or Tandem) using Meridian Link. This card cannot be used as an asynchronous port or to connect to an administrative and maintenance terminal. Use either the NT8D41 SDI paddle board or the QPC841 Quad Serial Data Interface Card to connect the Meridian 1 switch to an asynchronous serial peripheral.

Each Meridian 1 system can accommodate up to eight ESDI cards, for a total of 16 synchronous ports per system. The ESDI cards can be housed in the network slots of any of the following modules:

- NT5D21 Core/Network Module (slots 0 through 7) for system Options 51C, 61C, and 81C
- NT6D39 CPU/Network Module (slots 1 through 9 and 13) for system Options 51 and 61
- NT6D60 Core Module (slots 0 through 5) for system Option 81
- NT8D11 Common/Peripheral Equipment (CE/PE) Module (slots 4 through 9 in the “NET” area) for system Options 21, 21A and 21E
- NT8D34 CPU Module (slots 6 through 13) for system Option 71
- NT8D35 Network Module (slots 5 through 13) in active network groups for system Options 71 and 81
- NT9D11 Core/Network Module (slots 0 through 8) for system Option 61C

Note: When an ESDI card is installed in an NT6D60 Core Module, an NT8D34 CPU Module, or slot 13 of an NT6D39 CPU/Network Module in a dual-CPU system, any I/O device connected to the card does not function when the CPU in that module is inactive.

Physical description

The ESDI card circuitry is contained on a 31.75 by 25.40 cm (12.5 by 10 in.) printed circuit board. The front panel of the card is 2.54 cm (1 in.) wide. See Figure 12 on page 60. The front panel is equipped with an Enable/Disable (ENB/DIS) switch and a red LED. The LED lights when the following occurs:

- the ENB/DIS switch is set to DIS
- both ports are disabled in software
- none of the card's ports have been configured in software
- the switch settings on the card do not match the settings programmed in software

Figure 12
CPC513 ESDI Card front panel

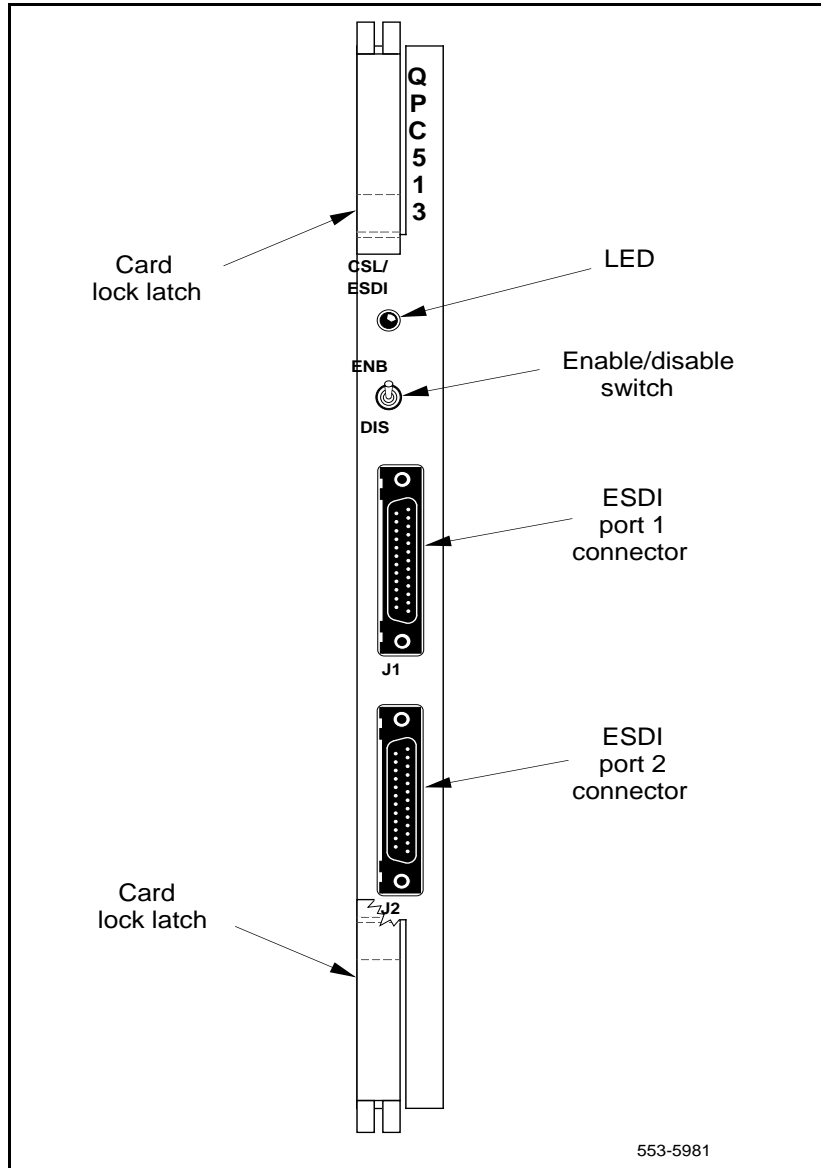

Functional description

The QPC513 ESDI Card is an intelligent, two-port synchronous serial data interface card. See Figure 13. The two serial input/output data ports terminate on DB-25 connectors on the front panel of the card.

Each port operates independently in synchronous mode, in half or full duplex, at speeds of up to 64 kbps. Each port can be connected to either Data Terminal Equipment (DTE) or Data Communications Equipment (DCE).

The electrical interface for the ESDI card may be either EIA RS-232-C or a proprietary high-speed interface. The high-speed interface combines features of RS-422-A for data and timing signals with features of RS-232-C for control signals.

Figure 13
ESDI card block diagram

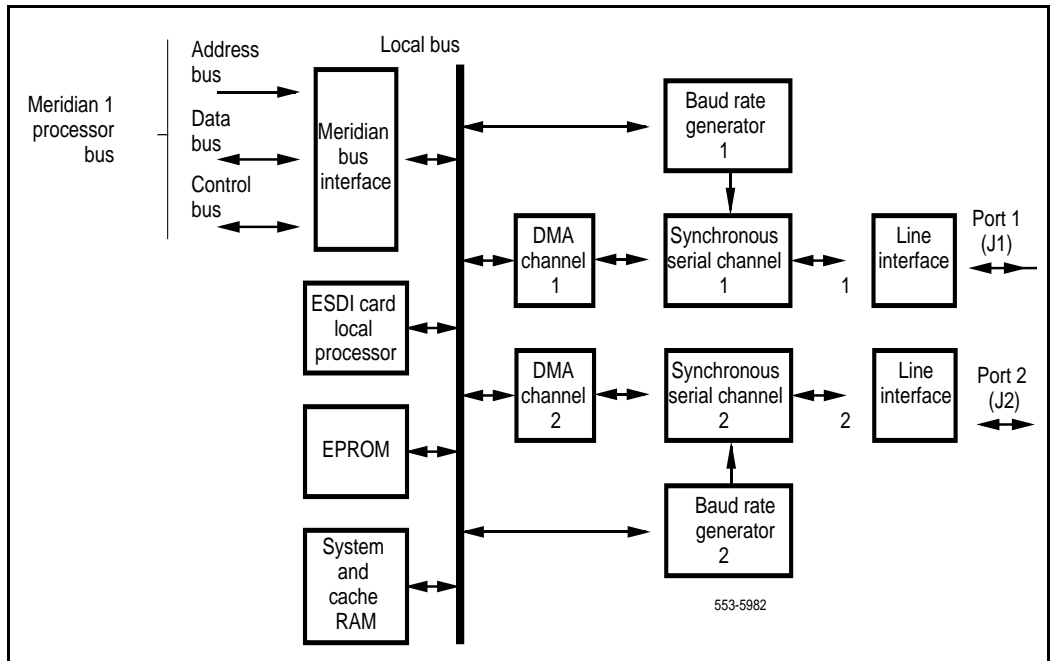

The QPC513 ESDI Card is an intelligent controller. The local micro-processor performs all of the overhead associated with synchronous data transfer. The Meridian 1 processor passes data to the ESDI card processor a byte at a time using conventional memory reads and writes. The ESDI card processor stores the data in a RAM cache on the ESDI card, and passes it to the synchronous communications chip in blocks using Direct Memory Access (DMA) techniques.

Synchronous communications

The ESDI cards supports LAPB, a subset of the HDLC synchronous protocol. A description of the LAPB protocol is shown in Appendix A, LAPB data link protocol on page 77.

The HDLC data link is a bit-oriented protocol. The information data bits are transmitted transparently across the link in packets. The maximum length of the information field for these packets is 128 octets, where an octet consists of 8 bits.

The characteristics of the synchronous communications ports are shown in Table 20.

Table 20
Characteristics of synchronous ports

Characteristics	Description
Duplex mode	half, (full)
Data rate (bps)	1200, 2400, (4800), 9600, 19200, 48000, 56000, 64000
Clock	(internal), external
Data Link Level LAPB protocol SL-1 address	(1), 3
Data Link Level LAPB protocol remote host address	(3), 1
Modify link control system parameters*	yes, (no)
Modify link performance thresholds (Note 1)	yes, (no)
<p>* See the Configuration Record (LD 17) in <i>Software Input/Output Guide Administration</i> (553-3001-311) to modify the link control system parameters and performance thresholds.</p> <p>Note: The values in parentheses are the default.</p>	

Clock timing option

The ESDI card offers two timing options:

- Internal: The ESDI card uses an internal timing source to synchronize data transfers to the external device.
- External: The ESDI card accepts a timing source from the high-speed interface connector to synchronize data transfers to the external device.

Test and maintenance features

The ESDI card has these built-in testing and maintenance capabilities:

Self-test

The ESDI card performs a self-test of its major components immediately after power-up. The self-test can also be initiated through the Link Diagnostic program LD 48. The self-test tests all ESDI functions up to, but not including, the ESDI line drivers and receivers.

Fault detection

Firmware on the ESDI card detects hardware faults on the card and link level LAPB protocol faults. It reports the faults to the CPU when predetermined thresholds (downloaded at initialization) have been exceeded.

Fault isolation

The ESDI/Command and Status Link (CSL) maintenance software takes the ESDI card out of service when the out-of-service thresholds are exceeded for the following:

- LAPB error conditions (for example, retransmission, Cyclic Redundancy Check (CRC) errors, overrun/underrun errors)
- Physical or link errors
- Detected hardware errors

Connection characteristics

The two DB-25 connectors on the front panel of the ESDI card provide connections to each of the two I/O ports. The electrical interface of these connectors is a modified version of the RS-422-A standard designed to drive high-speed data over long cable lengths (up to 100 ft). Table 21 shows the interconnection specifications for these ports.

Table 21
QPC513 interconnection specifications

Distance	Interconnection
<15.24 m (<50 ft)	Regular 25-conductor cable
>15.24 m and <30.48 m (>50 ft and <100 ft)	Twisted pair for balanced circuits
>30.48 m (>100 ft)	Network interface devices such as stand-alone modems or DS-1 facilities using Asynchronous/Synchronous Interface Module (ASIM) and Data Line Card (DLC)

Electrical interface options

Interface options are selected by inserting jumper plugs into the appropriate sockets on the card:

- **RS-232-C interface:** The EIA RS-232-C interface can be used for speeds up to 19.2 kbps and distances of less than 15.24 m (50 ft). The ESDI card supports a subset of the RS-232-C signals. See Table 22 on page 67.
- **High-speed interface:** The high-speed interface combines features of the RS-422-A standard for the data and timing signals with standard RS-232-C control signals. It is used when the signal rate is greater than 19.2 kbps and/or when the distance between the Meridian 1 and host is greater than 15.24 m (50 ft). No modems are needed if the distance is less than 30.48 m (100 ft).

The high-speed interface uses a proprietary pin assignment, rather than the standard 37-pin RS-449 arrangement. This pin arrangement is compatible with the Spectron Cable #75-025 for V.35 use. See Table 23 on page 68.

The data and timing signals on the high-speed interface use RS-422-A type differential line drivers and receivers in a balanced configuration. These drivers and receivers are able to drive higher data rate signals over longer distances than standard RS-232-C drivers and receivers. A typical connection using these drivers and receivers is shown in Figure 14.

Figure 14
Typical high-speed interface line driver and receiver

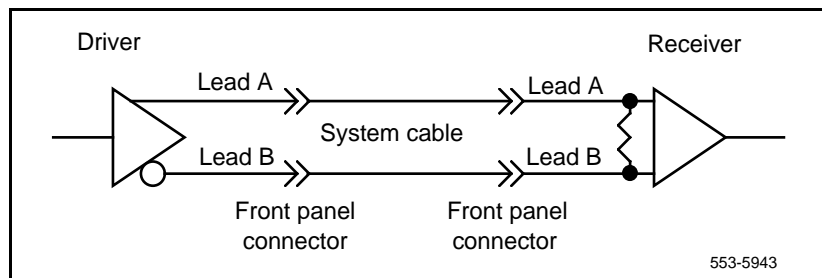

Connector pin assignments

Table 22 shows the pin assignments for J1 and J2 when the port is configured for RS-232-C interface, and Table 23 on page 68 shows the pin assignments for J1 and J2 when the port is configured for the high-speed interface.

Table 22
Connector J1 and J2 pin assignments – RS-232-C interface

Pin number	Signal functions	Signal source		EIA circuit
		To DCE	From DCE	
Ground and common return				
1	Shielded	n/a	n/a	
7	Signal ground (SG)	n/a	n/a	AB
Data				
2	Transmitted data (TX)	3	—	BA
3	Received data (RX)	—	3	BB
Control				
4	Request to send (RTS)	3	—	CA
5	Clear to send (CTS)	—	3	CB
6	Data set ready (DSR)	—	3	CC
8	Carrier detect (CD)	—	3	CF
20	Data terminal ready (DTR)	3	—	CD
Timing				
15	Transmitter signal element timing (DCE)	—	3	DB
17	Receiver signal element timing (DCE)	—	3	DD
24	Transmitter signal element timing (DTE)	3	—	DA
Note: Pins not used are 9 to 14, 16, 18, 19, 21, 22, 25.				

Table 23
Connector J1 and J2 pin assignments – high-speed interface

Pin number	Signal functions	Signal source		EIA circuit (lead)
		To DCE	From DCE	
Ground and common return				
1	Shield	n/a	n/a	
7	Signal ground (SG)	n/a	n/a	AB
Data				
2	Transmitted data – lead A	3	—	BA (A)
3	Received data – lead A	—	3	BB (A)
13	Transmitted data – lead B	3	—	BA (B)
16	Received data – lead B	—	3	BB (B)
Control				
4	Request to send (RTS)	3	—	CA
5	Clear to send (CTS)	—	3	CB
6	Data set ready (DSR)	—	3	CC
8	Carrier detect (CD)	—	3	CF
20	Data terminal ready (DTR)	3		CD
Timing				
12	Transmitter signal element timing (DTE) – lead B	—	3	DD (B)
14	Transmitter signal element timing (DCE) – lead B	—	3	DB (B)
15	Transmitter signal element timing (DCE) – lead A	—	3	DB (A)
17	Transmitter signal element timing (DTE) – lead A	—	3	DD (A)
23	Receiver signal element timing (DCE) – lead A	3	—	DA (A)
24	Receiver signal element timing (DCE) – lead B	3	—	DA (B)
Note: Pins not used are 9, 10, 11, 18, 19, 21, 22, 25.				

Configuring the ESDI card

Configuring the ESDI card consists of setting the port addresses using the address selection switch and setting the port interface options using the jumper blocks. The system software must then be configured to recognize the ESDI card. Figure 15 on page 71 shows the location of all option switches and jumper sockets on the ESDI card.

Address switch settings

The two ESDI ports on the card are addressed in pairs such as 0 and 1, 2 and 3, and so on). The address is set using switch S2. The switch settings used to select the address vary depending on whether the card is Style A or Style B. The “Style” can be read on the printed circuit board silk screen. The address of the card is set to match the device address defined in software.

Synchronous port address space is the same as asynchronous port address space. When selecting an address for the ESDI card, make sure that it will not conflict with an address currently being used by an asynchronous card.

Table 24 shows the ESDI card address switch settings.

Table 24
ESDI card address switch settings

Device Number		Switch S2 style A				Switch S2 style B			
Port 1	Port 2	1	2	3	4	1	2	3	4
0	1	off	off	off	on	off	off	off	*
2	3	on	off	off	on	off	off	on	*
4	5	off	on	off	on	off	on	off	*
6	7	on	on	off	on	off	on	on	*
8	9	off	off	on	on	on	off	off	*
10	11	on	off	on	on	on	off	on	*
12	13	off	on	on	on	on	on	off	*
14	15	on	on	on	on	on	on	on	*

* Switch S2, position 4 is not used on style B cards.

Figure 15
ESDI card option switch locations

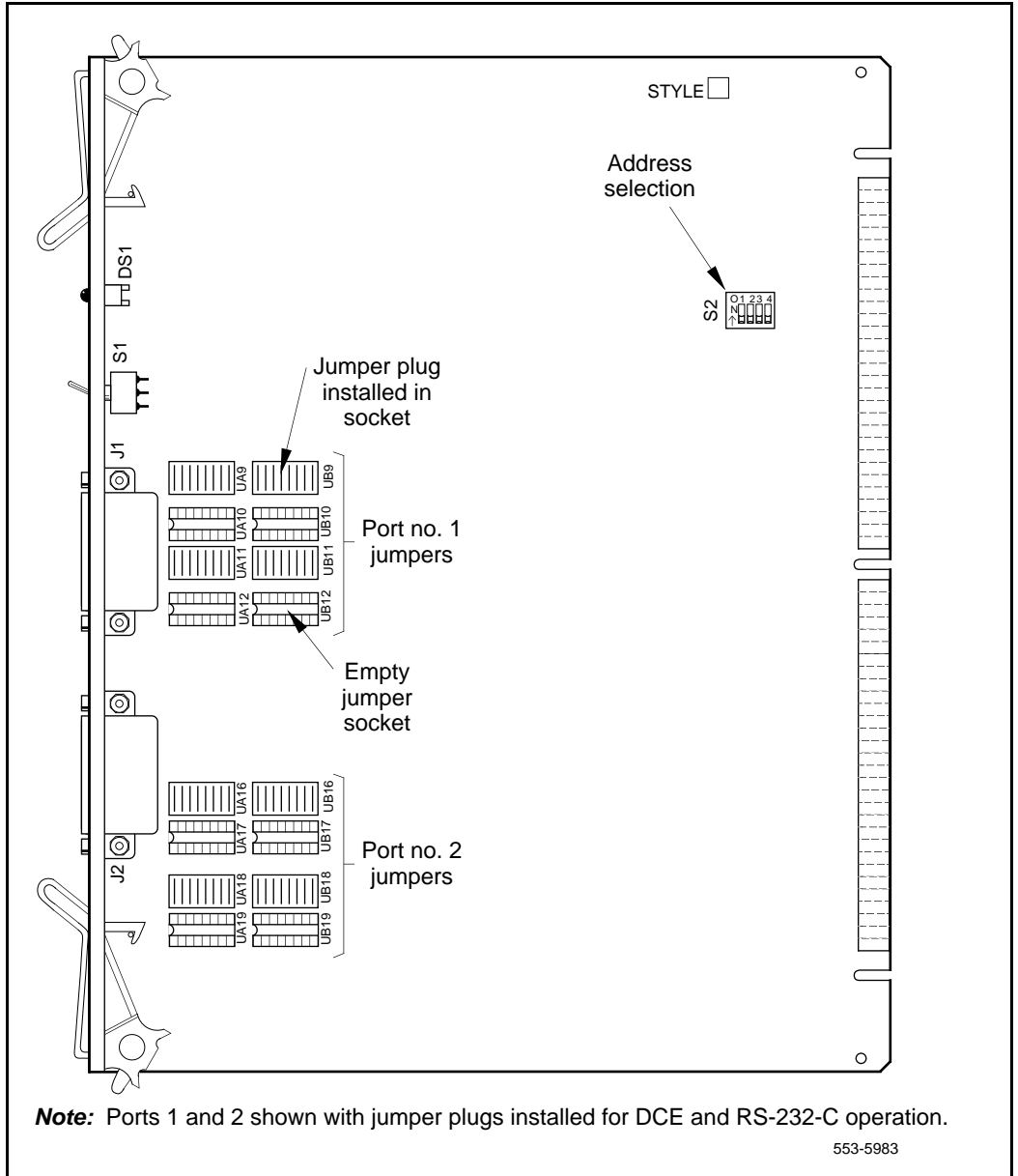

DTE/DCE mode jumper settings

The interface for each ESDI port is configured independently. Ports must be configured both for electrical interface (RS-232-C or high-speed) and mode (DTE or DCE). With the proper options set

- An ESDI port configured as DTE appears as a terminal to the user equipment.
- An ESDI port configured as DCE appears as a modem to the user equipment.

Interface options are set by installing option jumper plugs into the sockets indicated in Table 25 and Table 26.

Table 25
ESDI card DTE/DCE mode jumper settings

Mode	Port	Jumper socket designations	
		Data communication equipment (DTE)	1
Data terminal equipment (DCE)	1	UA9	UA11
Data communication equipment (DTE)	2	UA17	UA19
Data terminal equipment (DCE)	2	UA16	UA18

Table 26
ESDI card RS-232-C/high-speed interface jumper settings

Mode	Port	Jumper socket designations	
		RS-232-C interface	1
High-speed interface	1	UB10	UB12
RS-232-C interface	2	UB16	UB18
High-speed interface	2	UB17	UB19

Software service changes

All of the other ESDI port operating parameters are defined in software and downloaded to the assigned ESDI port. See Table 20 on page 63. These changes are made using the Configuration Record program (LD 17). Instructions for the Configuration Record program are found in the *Software Input/Output Guide Administration* (553-3001-311).

Some of the prompts that are commonly used when running the Configuration Record program (LD 17) are shown in Table 27. These parameters must be set for each ports if both ports are being used.

LD 17 – Serial port configuration parameters.

Prompt	Response	Description
REQ	CHG	Change configuration.
TYPE	CFN	Configuration type.
IOTB	YES	Change input/output devices.
ADAN	NEW TTY x New PRT x	Define a new system terminal (printer) port as device x, where x = 0 to 15.
CDNO	1–16	Use the ESDI card number to keep track of all ports.
DENS	DDEN	Double density SDI paddle board.
USER	xxx	Enter the user of port x. The values that can be entered depend on the software being used. See the <i>Software Input/Output Guide Administration</i> (553-3001-311) for details.
XSM	Yes, (No)	Port is used for the system monitor.

Applications

The QPC513 Enhanced Serial Data Interface Card is used any time that a high-speed, fully synchronous serial data communications channel is needed. The ESDI card is typically used to connect to the following:

- Meridian Mail
- A host computer using Meridian Link
- An auxiliary processor

The Meridian 1 processor transfers data to the ESDI card in blocks consisting of 1 to 128 eight-bit octets. Each block is processed in accordance with the LAPB subset of the HDLC protocol and is transmitted serially to the output port.

In receive mode, the ESDI card receives data serially from the input port packages in LAPB information frames. After determining that the block is error-free, the ESDI card supplies the data to the Meridian 1 processor as a block.

The ESDI card serial ports terminate on the card front panel. Figure 16 on page 75 shows the typical ESDI card connections in a system.

Figure 16
QPC513 ESDI card cabling

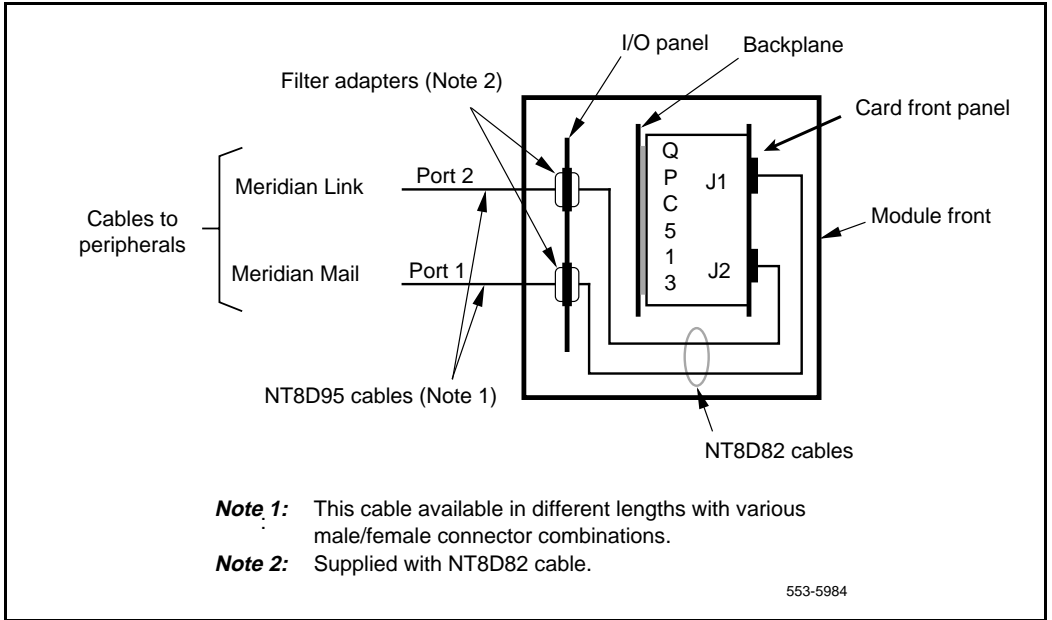

Appendix A: LAPB data link control protocol

Contents

This section contains information on the following topics:

Operation.....	77
Frame structure.....	78
LAPB balanced class of procedure.....	79
Commands and responses.....	80
Description of procedure.....	81

This chapter describes the LAPB Data Link Control protocol used with the QPC513 ESDI card. The protocol is a subset of the HDLC procedures which are described in International Organization for Standardization procedures ISO 3309-1979 (E), ISO 4335-1979 (E) and appendices 1 and 2, and ISO 6256-1981 (E). Refer to these procedures for complete LAPB details.

Applications which use an ESDI port in synchronous mode must conform to the following requirements.

Operation

Circuit Switch Equipment (CSE) transfers data to the QPC513 in blocks consisting of 1 to 128 eight-bit octets. Each block is processed in accordance with the LAPB subset of the HDLC protocol and transmitted serially to the line at a rate determined by the downloaded parameters.

The QPC513 card receives data serially from the line, packaged in LAPB information frames. After determining that a block is error free the data is supplied to the CSE as a block.

Frame structure

All transmissions are in frames and each frame conforms to the format shown in Table 28. In particular, frame elements for applications using a port on the QPC513 follow these LAPB conventions:

- Zero information field is permitted.
- Inter-frame time fill is accomplished by transmitting contiguous flags. This is compatible with AT&T Technical Requirement BX.25 and ADCCP standards.
- Extensions for the address field or the control field are not permitted. This requirement imposes constraints to satellite operations.
- Individual station addresses are assigned in service change for balanced configuration. The default ESDI address is 10000000. The far-end default address is 11000000.
- The LAPB basic control field (modules 8) format is implemented.
- Frame check sequence is implemented in accordance with LAPB procedures.

Table 28
LAPB frame structure

Flag	Address	Control	Information	FCS	Flag
01111110	8 bits	8 bits	unspecified (no. of bits)	16 bits	01111110

Legend:

Flag: Flag sequence – All frames start and end with the flag sequence. (A single flag is used as both the closing flag for one frame and the opening flag for the next frame.)

Address: Station address field – In command frames, the address identifies the station for whom the command is intended. In response frames, the address identifies the station from which the response originated.

Control: Control field – This field contains commands or responses and sequence numbers.

Information: Information field – Information may be any sequence of bits, usually related to a convenient character structure such as an octet, but may be an unspecified number (from 1 to 128) of bits unrelated to a character structure.

FCS: Frame check sequence.

LAPB balanced class of procedure

Applications which use ports on the QPC513 are automatically designated as BAC, 2, 8 (for example, balanced operation, asynchronous balanced mode class of procedure with optional functions 2 and 8 implemented).

Balanced configuration

A balanced configuration is one in which two combined stations have identical responsibilities for exchanging data and control information and for initiating error recovery functions, as shown in Figure 17.

Figure 17
Balanced configuration

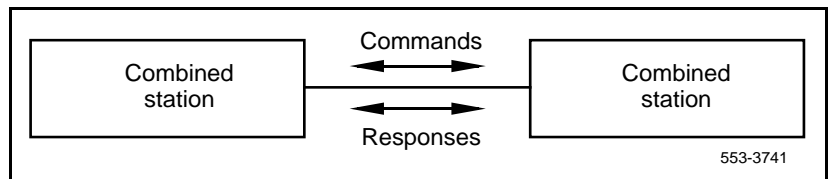

Combined station

A combined station has balanced link control capability and transmits both commands and responses to, and receives both commands and responses from the other combined station.

Asynchronous Balanced Mode

Asynchronous Balanced Mode (ABM) is a balanced, configured operational mode in which either combined station may send commands at any time and may initiate certain response frame transmissions without receiving permission from the other combined station.

Commands and responses

The elements of procedure are described in terms of actions which take place when a command is received. The classes of procedures are a combination of the frame structure and the set of elements that satisfy the requirements of a specific application. The LAPB Balanced Asynchronous Class of Procedure (BAC, 2, 8) is implemented. This is compatible with both BX.25 and ADCCP specifications. The basic set of commands and responses is listed in Table 29.

Table 29
Commands and responses

Command	Response	Option
I		8
RR	RR	
RNR	RNR	
REJ	REJ or FRMR	2
SABM	UA	
DISC	DM	
<p>Legend: I: Information RR: Receive ready RNR: Receive not ready REJ: Reject SABM: Set asynchronous balanced mode DISC: Disconnect RSET: Reset FRMR: Frame reject UA: Unnumbered acknowledge DM: Disconnect mode Option 2: Provides ability for more timely reporting of I frame sequence errors Option 8: Limits the procedure to allow I frames to be commands only</p>		

Description of procedure

The basic LAPB procedures must be implemented to satisfy the following:

- standard use of the poll/final bit (for more information, see ISO-4375-1979-[E])
- exception condition reporting and recovery implemented in accordance with BX.25 and ADCCP specifications
- link set-up and disconnect implemented according to BX.25 specifications

Index

A

ACD (Automatic Call Distribution), 11, 17, 43
 link to NT8D41BA paddleboard, 31
 address switch settings, 23, 50
 NT8D41BA QSDI, 38
 altitude ranges, 13
 asynchronous device compatibility, 11

B

backplane slots, 13, 19, 21
 backplane slots on NT8D41BA, 35
 baud rate generators, 45
 baud rates (data rates in bps), 12, 24, 51, 63
 baud rates on NT8D41BA QSDI, 37
 boards. *See* SDI (serial data interface) cards

C

cabling
 length considerations, 10
 NT8D41AA SDI paddle board, 29
 NT8D41BA QSDI paddle board, 42
 QPC513 ESDI (Enhanced Serial Data Interface), 65, 75
 QPC841 QSDI (Quad Serial Data Interface), 55, 56
 CDR (Call Detail Recording), 11, 17, 43
 link to NT8D41BA paddleboard, 31
 clock timing (internal/external), 63
 compatibility with Meridian 1 options (table), 11
 Configuration Record program, 40

configuring

NT8D41AA SDI paddle board, 23
 NT8D41BA QSDI paddle board, 37
 QPC513 ESDI (Enhanced Serial Data Interface), 67
 QPC841 QSDI (Quad Serial Data Interface), 50
 serial ports, 27, 54
 system software for SDI cards, 14

connector pin assignments

NT8D41 SDI paddle board, 22
 NT8D41BA QSDI paddle board, 36
 QPC513 ESDI (Enhanced Serial Data Interface), 67
 QPC841 QSDI (Quad Serial Data Interface), 48

console connection, 55

CPU area of backplane, 21

CPU area of NT8D41BA's backplane, 35

Ddata interface cards. *See* SDI (serial data interface) cardsdata rates. *See* baud rates

DCE (data communication equipment) emulation, 12

pin assignments and functions, 22, 36, 49
 switch settings, 24

DTE (data terminal equipment) emulation, 12

pin assignments and functions, 22, 36, 49
 switch settings, 24

DTE/DCE mode on NT8D41BA, table, 39

duplex mode, 63

E

electromagnetic interference, 14
electrostatic discharge, 14
emulation of data equipment, 12
environmental specifications, 13

G

grounding, 22, 48
grounding on the NT8D41BA, 36

H

handshake signals, 10
Hayes modems, 28, 41, 55
HDLC data link, 62
high-speed interfaces, 61, 65
humidity ranges, 13

I

interface cards. *See* SDI (serial data interface) cards
I/O device selectability, 12

J

J1/J2 connectors, 22, 45, 48, 49, 55, 67
J1-J4 connectors
 on NT8D41BA QSDI, 36
jumper settings for DTE/DCE mode for QPC513, 72

L

LAPB data link control protocol
 balanced class of procedure, 79
 commands and responses, 80
 described, 10
 error condition detection, 64
 frame structure, 78
 operation, 77, 81
 provision of, 12
 support for, 62
LD, 15, 25, 54, 64, 73
LD 17, 14

LED indicators

NT8D41AA SDI paddle board, 18
QPC513 ESDI (Enhanced Serial Data Interface), 59
QPC841 QSDI (Quad Serial Data Interface), 45

LED's purpose on NT8D41BA, 32

loop interface support for 20 mA current, 18, 32, 44

M

maintenance

 of Meridian 1 systems, 21
 of SDI cards, 15

maintenance of Meridian 1

 role of QSDI paddle board in, 35

Meridian 1 systems, 10

See also SDI (serial data interface) cards

Meridian Link program, 12, 58, 74

Meridian Mail option, 12, 58, 74

modem ports, 20, 28, 34, 41, 55

mounting

NT8D41AA SDI paddle board, 17
NT8D41BA QSDI paddle board, 11, 31
QPC513 ESDI (Enhanced Serial Data Interface), 11, 58
QPC841 QSDI (Quad Serial Data Interface), 11, 44

MTBF (Mean Time Between Failure), 14

N

network area of backplane, 21

network area of NT8D41BA backplane, 35

NT5D21 Core/Network Module

 location of QSDI paddleboard, 32

NT6D39 CPU/Network Module, 18, 44, 58

 location of QSDI paddleboard, 32

NT8D11 CE/PE (Common/Peripheral Equipment) Module, 18, 44, 58

NT8D34 CPU Module, 44

NT8D35 Network Module, 44, 58

NT8D41 SDI paddle board

 applications, 28
 connector pin assignments, 22

NT8D41AA SDI paddle board

- cabling, 29
- configuring, 23
- described, 18
- mounting, 17
- switch settings, 23

NT8D41BA QSDI paddle board

- address switch settings, 38
- applications, 41
- baud rates (table), 37
- cabling the NT8D41BA paddle board, 42
- configuring, 37
- connector pin assignments, 36
- diagram showing option switches, 33
- mounting, 11, 31
- physical description, 32
- ports and port types, 11
- switch settings, 37
- UARTS, 34
- UARTS, drivers, receivers (diagram), 34

NT8D41BA QSDI ports

- RS-232-C, 41

NT8D46 cables, 29

NT8D46 cables for the QSDI, 42

NT8D82 cables, 55

NT8D84AA cables, 28, 29

NT8D84AA cables for the NT8D41BA QSDI, 41

NT8D84AA cables for the QSDI, 42

NT8D90 cables, 56

NT8D93 cables, 28, 29

NT8D93 cables for the NT8D41BA QSDI, 41

NT8D93 cables for the QSDI, 42

NT8D95 cables, 55, 56

NT8D96 cables, 48, 56

NT9D11 Core/Network Module, 18, 58

- location of QSDI paddleboard, 32

O

option switches (NT8D41BA QSDI)

- diagram showing location of, 33

P

pin assignments. *See* connector pin assignments

port types for SDI cards (table), 11

ports

- and port types, 11, 12, 18, 32
- how addressed (on NT8D41BA), 32
- RS-232-C, 17, 28, 31, 43
- serial, 18, 20, 27, 32, 44, 45, 54
- serial, uses for, 34
- synchronous, 58

power consumption, 13

printer ports, 20, 34

prompts and responses LD 17, 27, 54, 73

Q

QCAD290 cables, 55

QCAD42 cables, 55

QPC513 ESDI (Enhanced Serial Data Interface)

- applications, 74
- cabling and connections, 65, 75
- configuring, 67
- connector pin assignments, 67
- described, 57
- mounting, 11, 58
- ports and port types, 11
- testing and maintenance, 64

QPC841 QSDI (Quad Serial Data Interface), 44

- applications, 55
- cabling, 56
- configuring, 50
- connector pin assignments, 48
- described, 43
- mounting, 11, 44
- switch settings and locations, 50

R

- RS-232-C interface, 10, 12, 65
 - NT8D41AA QSDI paddle board, 10
 - NT8D41AA SDI paddle board, 17, 28
 - NT8D41BA QSDI paddle board, 10, 11, 12, 31, 41
- QPC513 Enhanced Serial Data Interface Card, 10, 12, 65
- QPC513 ESDI Card, 11
- QPC841 Quad Serial Data Interface Card, 10, 43
- RS-422-A interface, 12, 66

S

- SDI (serial data interface) cards
 - compatibility with Meridian 1 options, 11
 - configuring system software, 14
 - connectable synchronous and asynchronous devices, 11
 - described, 7, 10
 - features, 12
 - installation, 11, 14
 - maintenance, 15
 - ports and port types, 11
 - related documentation, 7, 14
 - specifications, 13
 - See also* NT8D41 SDI paddle board; QPC513 ESDI (Enhanced Serial Data Interface); QPC841 QSDI (Quad Serial Data Interface)
- serial connectors, where located, 11
- serial data interface cards. *See* SDI (serial data interface) cards
- serial ports
 - configuring, 27, 54, 73
 - NT8D41AA Serial Data Interface Card, 18, 20
 - NT8D41BA Quad Serial Data Interface Card, 32, 34
 - QPC513 Enhanced Serial Data Interface Card, 58, 61
 - QPC841 Quad Serial Data Interface Card, 44

- signal functions
 - NT8D41 SDI paddle board, 22
 - NT8D41BA QSDI paddle board, 36
 - QPC513 ESDI (Enhanced Serial Data Interface), 67
 - QPC841 QSDI (Quad Serial Data Interface), 48
- signal rates, 10
- slots, 11
- software. *See* configuring.
- switch settings and locations
 - NT8D41AA SDI paddle board, 23
 - NT8D41BA QSDI paddle board, 37
 - QPC513 ESDI (Enhanced Serial Data Interface), 67
- switch settings, QSDI
 - addresses (table), 38
 - baud rates, 37
 - DCE/DTE emulation, 39
- synchronous device compatibility, 11, 12

T

- temperature ranges, 13
- terminal
 - ports, 20
- terminal ports, 34
- terminals
 - administration and maint., link to Meridian 1, 31
 - administration and maintenance, 17
 - background for hotels/motels, 11, 17, 31, 43
 - for administration and maintenance, 11, 43

U

- UART (Universal Asynchronous Receiver/Transmitter), 20, 23, 34, 45, 47
- UART for addressing on the QSDI, 38

V

- voice-mail option (Meridian Mail), 12
- voltages, 13

Meridian 1
Serial Data Interface Cards
Description

Copyright ©1994 –2002 Nortel Networks
All Rights Reserved

Information is subject to change without notice. Nortel Networks reserves the right to make changes in design or components as progress in engineering and manufacturing may warrant. This equipment has been tested and found to comply with the limits for a Class A digital device pursuant to Part 15 of the FCC rules, and the radio interference regulations of Industry Canada. These limits are designed to provide reasonable protection against harmful interference when the equipment is operated in a commercial environment. This equipment generates, uses and can radiate radio frequency energy, and if not installed and used in accordance with the instruction manual, may cause harmful interference to radio communications. Operation of this equipment in a residential area is likely to cause harmful interference in which case the user will be required to correct the interference at their own expense.

SL-1 and Meridian 1 are trademarks of Nortel Networks.

Publication number: 553-3001-107

Document release: Standard 7.00

Date: January 2002

Printed in Canada

